

FLEXSTATION[®]

DESKING
SYSTEM

planning guide



Introduction

FlexStation® is designed to meet the demands and flexibility of the modern office. Designed as a freestanding worksurface based system, FlexStation adapts from individual areas to shared workstations to cluster groupings to managerial modules. A wide variety of worksurface sizes and shapes meet the individual needs of all employees. Filing is accommodated with under-surface mounted pedestals, mobile pedestals and freestanding lateral files. Overhead storage units can be configured as open shelving or with lockable flipper doors. Personal filing requirements are handled by unique paper management components. Privacy screens, with tackable surface, help establish territory and seated-height privacy, while maintaining standing-height visual contact. FlexStation's design integrates function and ergonomics to provide solutions that meet ANSI/HFS 100-2007 and ADA user requirements.

PowerUp® Worksurfaces offer power and data access to meet most power and communications requirements.

FlexStation is offered in a wide range of colorful laminates, fabrics, and trims to meet your design expressions.

With the help of this Planning Guide, you can provide solutions to meet your client's needs.

Table of Contents

FlexStation Overview.....	2
Worksurface Planning	
BASIC WORKSURFACES	4
TRANSITIONAL WORKSURFACES	8
MOBILE TABLES	12
FLEXSTATION WITH POWERUP	13
PEDESTAL STORAGE	14
LATERAL FILES	15
WORKSURFACE ACCESSORIES	16
FlexStation Overhead Storage	
FLIPPER DOOR OVERHEAD STORAGE	17
UNIVERSAL & VENUS OVERHEAD STORAGE	18
OVERHEAD STORAGE ACCESSORIES	19
PAPER MANAGEMENT	20
FlexStation Privacy Screens	
PRIVACY SCREENS	21
FlexStation Design Review	
WORKSURFACES	22
FlexStation Specifications.....	24

FlexStation Overview

FlexStation is a system of tables and components that are designed to work together to create many different workstation options. The illustration shows the system, its components and their typical applications (Figure 1).

Figure 1

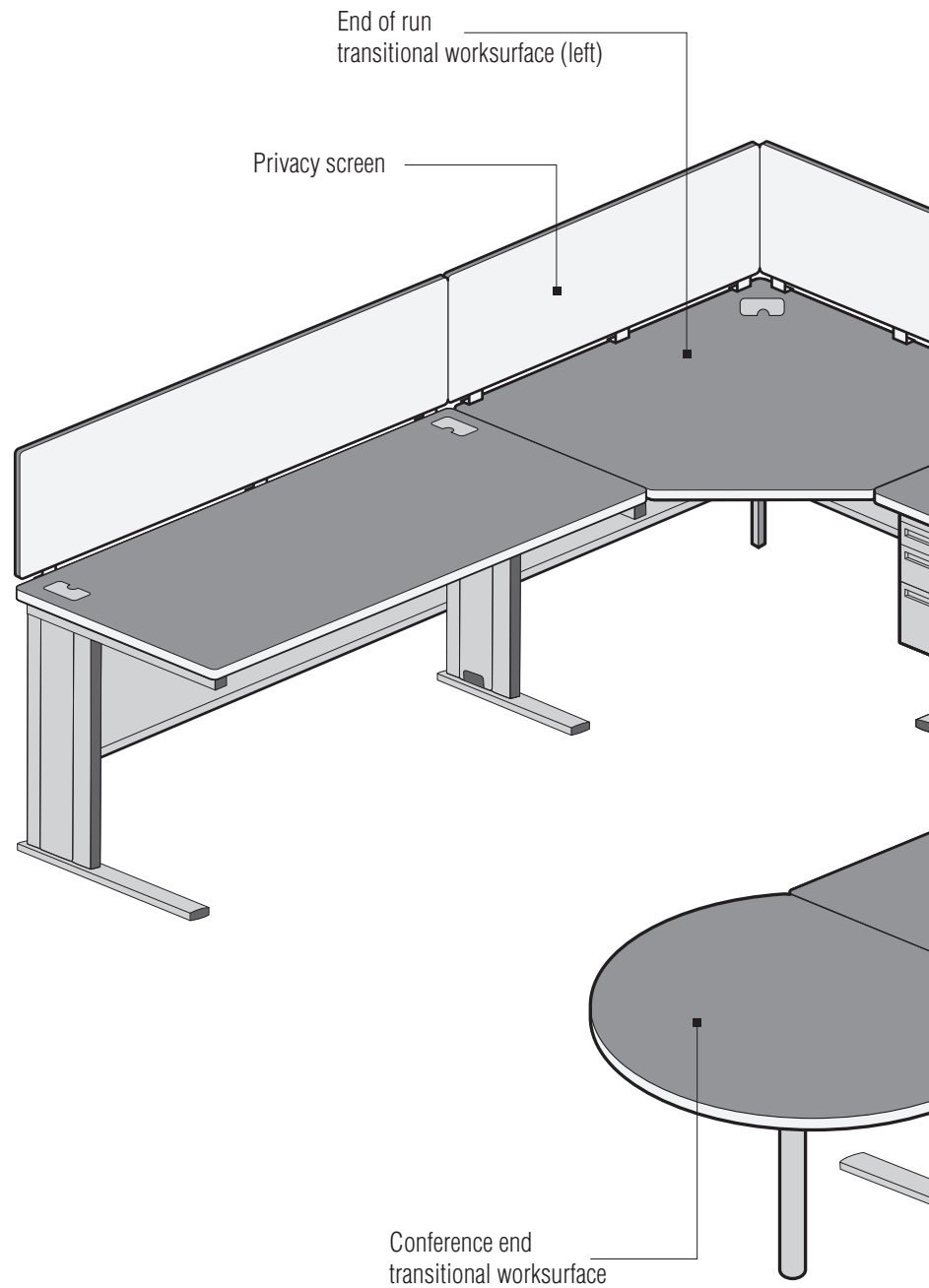

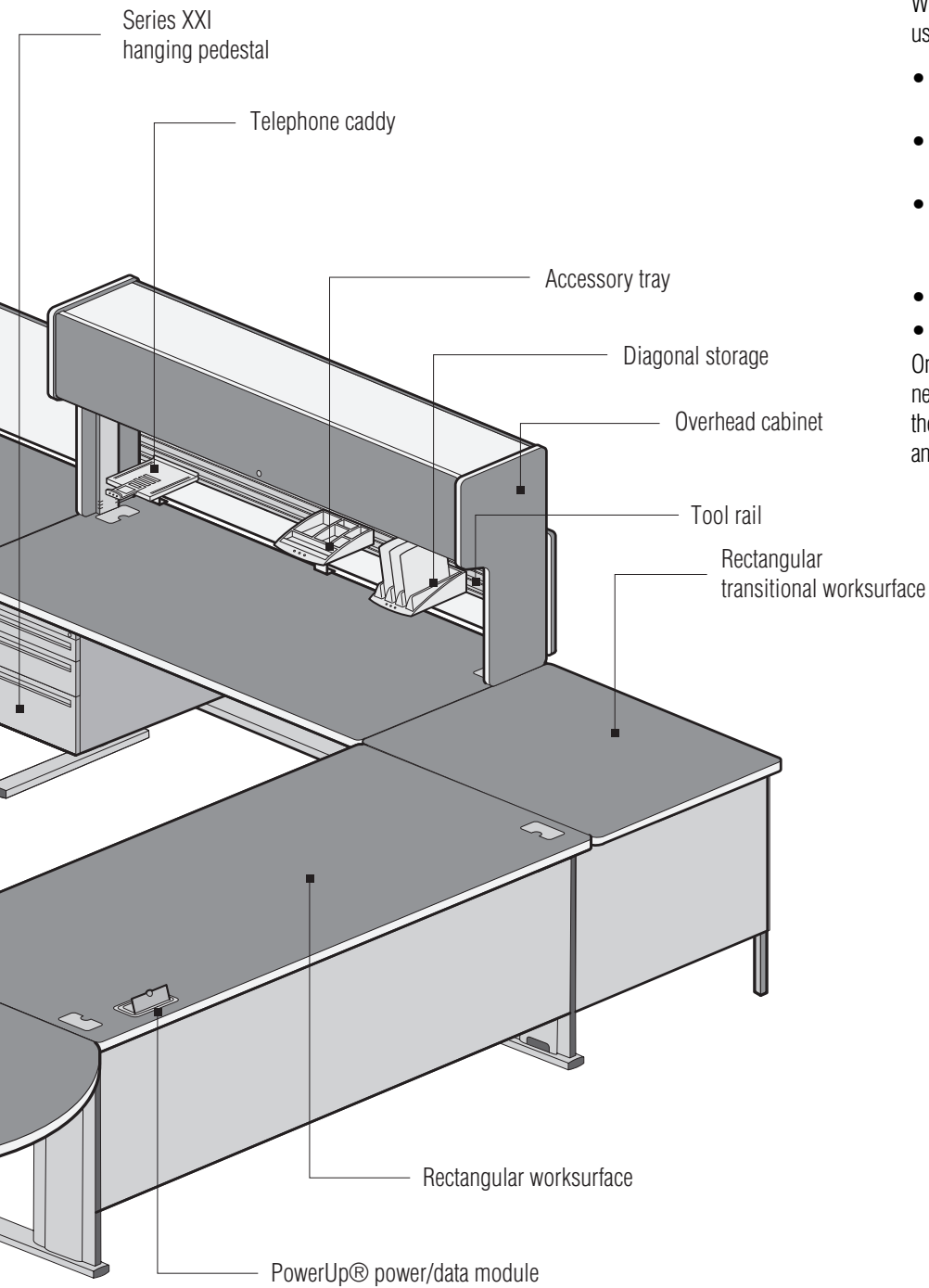

FLEXSTATION PLANNING

When planning your FlexStation workstations, survey the users for their needs by considering the following:

- How much worksurface area does each user need? What type of worksurfaces are needed?
- What accommodations must be made for computers, printers, power cables and low-voltage wires?
- How much and what type of storage space does each user need: Under the worksurface? Freestanding pedestals or lateral files? Overhead shelves or flipper door storage?
- What types of paper management units are needed?
- What level of privacy or accessibility is required?

Once you have surveyed the users and established their needs, you can design a FlexStation environment to meet those needs using the products described in this planning and specifying guide.

Worksurface Planning

Worksurfaces define the shape of the workstation and provide support for overhead storage, hanging pedestals, electrical componentry and privacy screens. Basic worksurfaces serve as primary worksurfaces, while other types meet special

requirements. The following pages show the shapes and sizes that are currently available.

BASIC WORKSURFACES

Basic Worksurfaces serve as primary worksurfaces, while other worksurface types meet specialized requirements. Basic Worksurfaces are available in the following sizes and shapes:

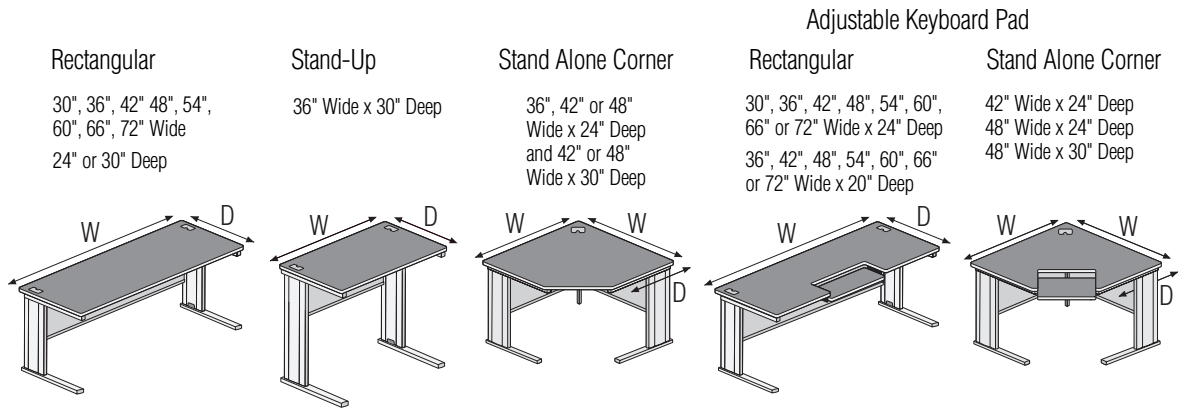

Heights:

27"	■		■	■	■
29"	■		■	■	■
42"		■			

Edges:

2mm PVC	■	■	■	■	■
---------	---	---	---	---	---

Worksurface tops feature a 1-1/4" solid core with high-pressure laminate surface, available in a choice of 30 colors. The laminate on Corner and Keyboard Corner Worksurfaces runs diagonally, paralleling the front edge. Tops are available with 2mm PVC edge in a choice of five edge colors.

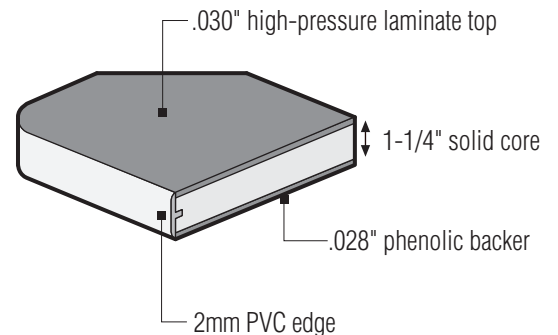

Worksurface Planning

Figure 3

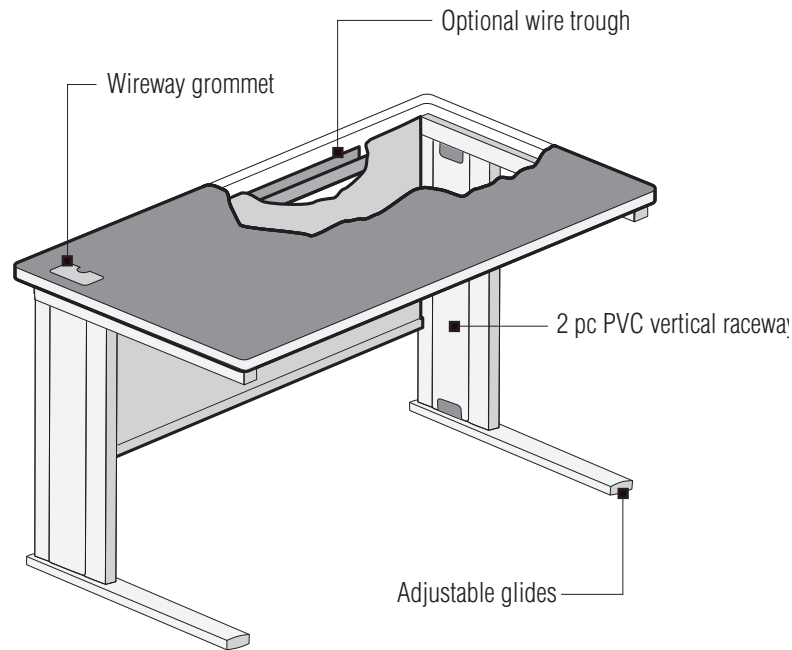

BASIC WORKSURFACES CONT...

Rectangular Worksurface

Basic Rectangular Worksurfaces include two wireway grommets, located in the back corners of each worksurface. Grommet color is chosen as a separate selection during configuration. The modesty panel attaches to the inside of the legs. An optional wireway trough for wire management is located behind the top of the modesty panel.

Worksurfaces are supported by a heavy-gauge, seam-welded tubular steel frame and two welded steel legs joined by a steel modesty panel. Legs and modesty panels are color matched and available in various powdercoat finishes. Internal vertical 2 pc PVC raceways are located on the inside of each leg to provide for easy wire management from the floor to the worksurface. Legs are equipped with adjustable chrome-plated glides to compensate for uneven floors (Figure 3). Separate Caster Kits may be ordered that include four casters, two with locks. Casters add 2" to the height of the worksurface.

Legs are available in two depths, standard and transitional. Transitional legs are six inches shorter in depth than the standard leg. This allows for more clearance for feet and chair movement where worksurfaces join in a straight line or corner applications.

Stand-up Worksurface

The Stand-up Worksurface has the same features as the rectangular worksurface, but is available in only one size; 30" deep by 36" wide by 42" high with the standard depth legs.

Stand Alone Corner Worksurface

Stand Alone Corner Worksurfaces have the same basic construction as the rectangular worksurfaces. As the name implies, the Stand Alone Corner Worksurface is used where a freestanding corner worksurface is needed. In freestanding applications, standard legs must be used. If attached to a Basic Rectangular Worksurface, transitional legs may be ordered for the sides of the attachment on both worksurfaces. Standard with 3 grommets.

Rectangular Adjustable Keyboard Pad Worksurfaces

Rectangular Adjustable Keyboard Pad Worksurfaces have the same construction features as the Basic Worksurface except for the addition of the 10" by 24" keyboard pad. The pads have a 3" height adjustment, a tilt range of 15° positive and 15° negative, and 1" forward extension. Rectangular Adjustable Keyboard Pad Worksurfaces are available with the keyboard pad located left, right or center on widths of 48", 54", 60" and 72". The 36" and 42" wide worksurfaces are available with the keyboard pad located in the center position only.

Corner Adjustable Keyboard Pad Worksurfaces

Corner Adjustable Keyboard Pad Worksurfaces provide a fixed height worksurface with the 10" by 24" adjustable keyboard pad where a freestanding corner worksurface is needed. The corner worksurface is available with 27" and 29" high standard depth legs.

Worksurface Planning

BASIC WORKSURFACES CONT...

Stand Alone
Corner Curvilinear

36", 42", 48" Wide x 24" Deep
42", 48" Wide x 30" Deep

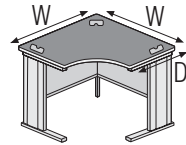

Stand Alone
Corner Reduction

24" Deep x 42" Wide x 30" Deep
24" Deep x 48" Wide x 30" Deep

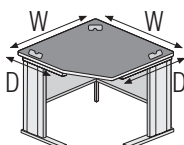

Stand Alone Corner
Curvilinear Reduction

24" Deep x 42" Wide x 30" Deep
24" Deep x 48" Wide x 30" Deep

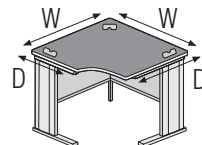

Heights:

27"	■	■	■
29"	■	■	■

Edges:

2mm PVC	■	■	■
---------	---	---	---

Curvilinear

24" Deep x 42" 48", 54",
60", 66", 72" Wide x 24"
or 30" Deep

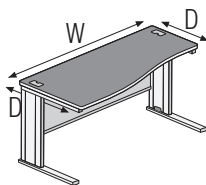

"P" Shaped

24" Deep x 48" Wide x
60", 66", 72" Long
30" Deep x 48" Wide x
66", 72" Long

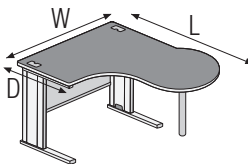

Piano Peninsula

24" Deep x 48" Wide x
60", 66", 72" Long
30" Deep x 48" Wide x
66", 72" Long

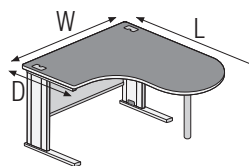

Square Shoe Peninsula

24" Deep x 48" Wide x
60", 66", 72", 84" Long
30" Deep x 48" Wide x
66", 72", 84" Long

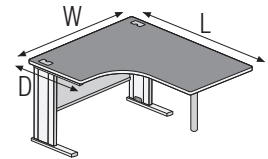

Heights:

27"	■	■	■	■
29"	■	■	■	■

Edges:

2mm PVC	■	■	■	■
---------	---	---	---	---

Worksurface Planning

BASIC WORKSURFACES CONT...

Stand Alone Corner Curvilinear Worksurface

Stand Alone Corner Curvilinear Worksurfaces have the same basic construction as the rectangular worksurfaces. The Stand Alone Corner Curvilinear Worksurface is used where a freestanding corner worksurface is needed to continue a radiused front edge around a corner between same depth worksurfaces. When attached to a rectangular worksurface or between two rectangular worksurfaces, transitional legs may be ordered for the sides of the attachment on both worksurfaces. In freestanding applications, standard legs must be used. Three grommets are standard for corner overhead option.

Stand Alone Corner Reduction Worksurface

Corner Reduction Worksurfaces are designed to accommodate a 30" deep worksurface on one side and a 24" worksurface on the other side. Reduction Worksurfaces have a meaningful part number which indicates the dimensions of the worksurface. For example a reduction worksurface that is 30" deep on the left, as you face the worksurface, 48" wide and 24" deep on the right would have the dimensions included in the part number in order from left-to-right, 304824. Three grommets are standard.

Stand Alone Corner Curvilinear Reduction Worksurface

Corner Curvilinear Reduction Worksurfaces provide a radiused front edge around a corner between a 30" deep worksurface and a 24" deep worksurface. Reduction Worksurfaces have a meaningful part number which indicates the dimensions of the worksurface. For example: a reduction worksurface that is 30" deep on the left, as you face the worksurface, 48" wide and 24" deep on the right would have the dimensions included in the part number in order from left-to-right, 304824. Three grommets are standard.

Curvilinear Worksurface

Curvilinear Worksurfaces have the same basic construction as the rectangular worksurfaces except for the front edge that makes a reduction from 30" deep to 24" deep. Reduction Worksurfaces have a meaningful part number which indicates the dimensions of the worksurface. For example: a reduction worksurface that is 30" deep on the left, as you face the worksurface, 48" wide and 24" deep on the right would have the dimensions included in the part number in order from left-to-right, 304824.

Peninsula Worksurfaces

Peninsula Worksurfaces are available as Basic Worksurfaces in three different shapes; "P" shaped, Piano shaped and Square Shoe shaped. Peninsula Worksurfaces have the same basic construction as the regular worksurfaces except for the peninsula extension and additional leg. Peninsula Worksurfaces must be specified for the location of the peninsula. When facing the worksurface, if the peninsula extends from the right side of the worksurface, it is a right peninsula. If it extends from the left side, it would be specified left peninsula.

Worksurface Planning

TRANSITIONAL WORKSURFACES

Transitional Worksurfaces are used to connect two Basic Worksurfaces together to form a corner or to end a run of Basic Worksurfaces. They are available in the following sizes and shapes:

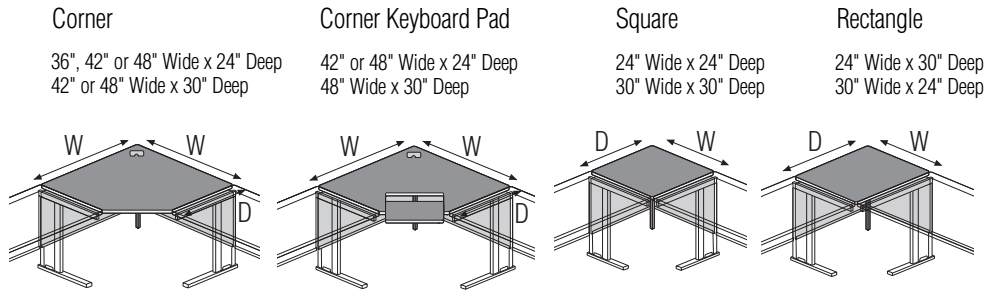

Heights:

29" to 29"	■	■	■	■
29" to 27"	■	■	■	■
27" to 27"	■	■	■	■
Edges:				
T-Molded	■	■	■	■
Post-Formed	■			
2mm	■	■	■	■

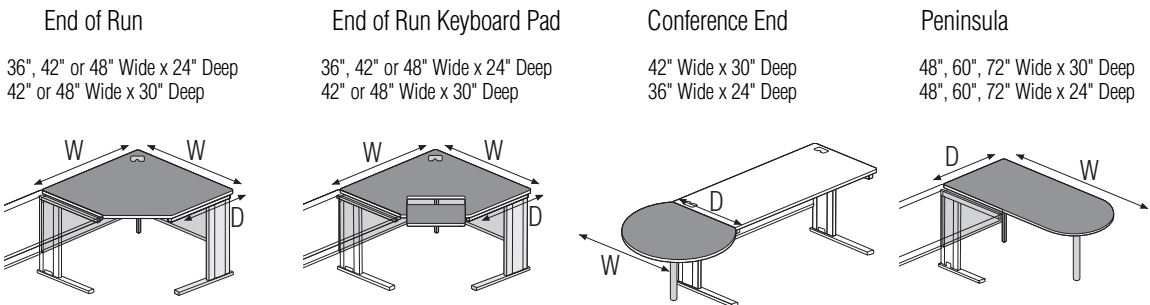

Heights:

27"	■	■		
29"	■	■	■	■
Edges:				
T-Molded	■	■	■	■
Post-Formed	■			
2mm	■	■	■	■

Transitional Worksurfaces

Transitional Worksurfaces make the transition around corners and rely on fixed height Basic Worksurfaces for their support.

Transitional Worksurfaces feature full wrap modesty panels and 1¼" solid core tops with high-pressure laminate surface. Corner and End of Run Worksurfaces have a grommet located in the back corner and are available with the optional wireway

trough. Hardware is included for attachment to adjoining worksurfaces for the condition specified. For same height installations, two splice plates are provided; for 29" to 27" installations, a splice plate and "Z" bracket are provided.

For Transitional Worksurfaces you must specify:

1. Transition Direction to determine the proper mounting hardware.

Worksurface Planning

Figure 6

Transitional worksurface modesty panels attach to support legs of adjoining basic worksurfaces to provide a full wrap finished appearance

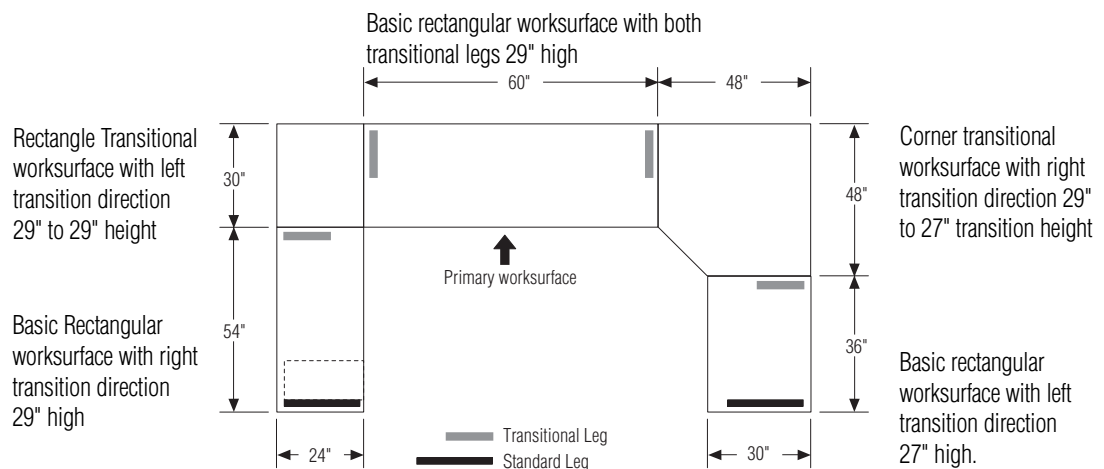
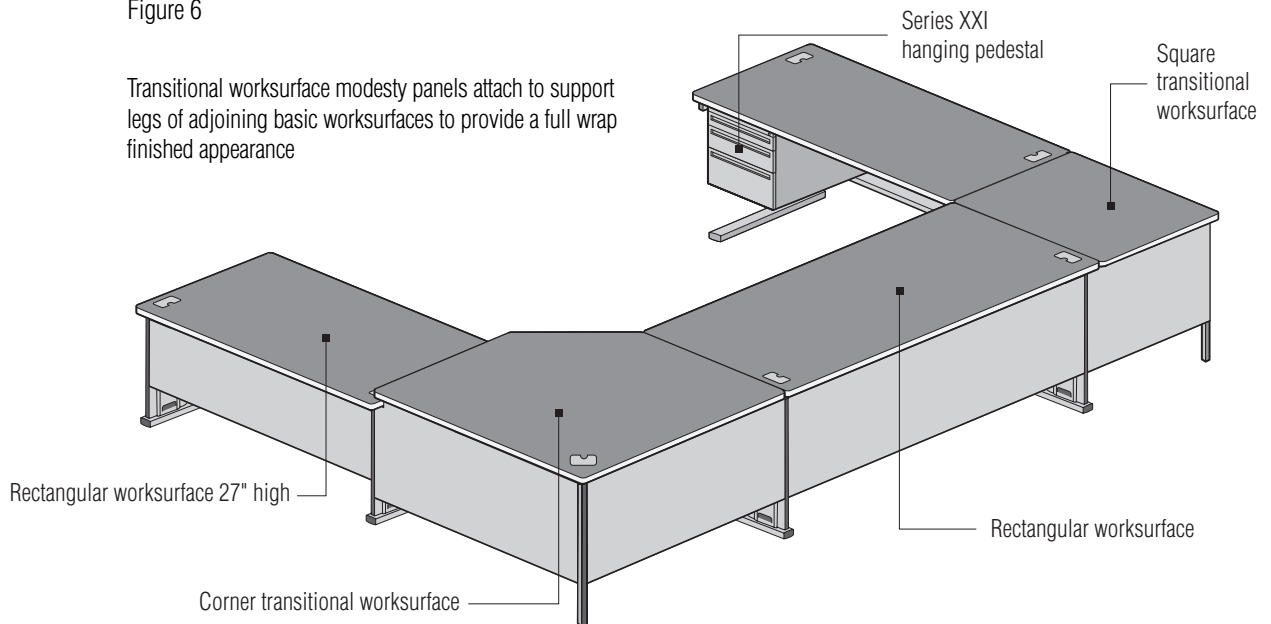

TRANSITIONAL WORKSURFACES CONT...

- Transition Direction is determined by the relationship of the Transitional Worksurface to the primary Basic Worksurface. The primary worksurface is the major work area and is determined by its size, height, width and depth to be the largest worksurface in the workstation. When facing the primary worksurface, a right transition attaches to your right (Figure 6).
 - For a square, corner or triangular transitional worksurface at the same height (29" to 29" or 27" to 27"), direction is not required and you can specify (x) for none. However, care should be taken to specify the correct direction for Rectangle, End of Run and the 29" to 27" height change to ensure the proper hardware and legs are included.
2. Transition Height for Transitional Worksurfaces.
 - All Transitional Worksurfaces, except the End of Run, Conference End and Peninsula Worksurfaces are available in three height options; 29" to 29", 29" to 27" and 27" to 27" and need to be specified.
 3. Location of transitional legs on adjoining Basic Worksurfaces.
 - Transitional legs should be specified whenever two worksurfaces are joined by a Transitional Worksurface. The End of Run Worksurface also has the choice of a Standard or Transitional Leg (Figure 6).

Worksurface Planning

TRANSITIONAL WORKSURFACES CONT...

Corner Transitional Worksurface

Corner Transitional Worksurfaces are available in three sizes: 36" by 36", 42" by 42" and 48" by 48". The 36", 42" and 48" worksurfaces have sides that match the 24" deep worksurfaces and the 42" and 48" has sides that match the 30" deep worksurfaces. They include a $\frac{7}{8}$ " square tubular corner support leg with a stainless steel adjustable glide and full wrap modesty panels with wire management ports located in the top center of each panel. Transitional worksurface tops attach to fixed height Basic Worksurfaces at the worksurface. The modesty panels attach to the legs of the adjoining Basic Worksurface to provide a full wrap finished appearance. Tops are available in the same construction and finishes as Basic Worksurfaces and include one grommet located in the back corner.

Corner Keyboard Pad Transitional Worksurface

Corner Keyboard Pad Transitional Worksurfaces have the same construction and features as the Corner Transitional Worksurface with the addition of the 10" by 24" keyboard pad. The pads have a 3" height adjustment, a tilt range of 15° positive and 15° negative and 1" forward extension. They are available in 42" by 42" and 48" by 48" with the 42" and 48" surface matching the depth of a 24" deep fixed height Basic Worksurface and the 48" surface matching the 30" deep.

Square Transitional Worksurface

Square Transitional Worksurfaces are available as 24" or 30" square units and are used with matching depth fixed height Basic Worksurfaces to fill in a corner. They include a $\frac{7}{8}$ " square tubular corner support leg with a stainless steel adjustable glide and full wrap modesty panels with wire management ports located in the top outside corner of each panel.

Rectangle Transitional Worksurface

Rectangle Transitional Worksurfaces are 24" by 30" and are used to match a 24" deep fixed height Basic Worksurface with a 30" deep worksurface at a corner. Special attention must be paid to the transition direction: either a Right (R) or Left (L) transition must be specified. Worksurfaces include a $\frac{7}{8}$ " square tubular corner support leg with a stainless steel adjustable glide and full wrap modesty panels with wire management ports located in the top outside edge of each panel.

End of Run Transitional Worksurface

End of Run Transitional Worksurfaces are available in three sizes: 36" by 36", 42" by 42" and 48" by 48". The 36", 42" and 48" worksurface units attach to 24" deep worksurfaces and the 48" unit also attaches to 30" deep worksurfaces. They include an end support leg, a $\frac{7}{8}$ " square tubular corner support leg with a stainless steel adjustable glide and full wrap modesty panels with wire management ports located in the top center of each panel.

End of Run Transitional Keyboard Pad Worksurface

End of Run Transitional Keyboard Pad Worksurfaces have the same construction and features as the End of Run Transitional Worksurface with the addition of the 10" by 24" keyboard pad. The pads have a 3" height adjustment, a tilt range of 15° positive and 15° negative, and 1" forward extension. They are available in 42" by 42" and 48" by 48" with the 36", 42" and 48" surface matching the depth of a 24" deep fixed height Basic Worksurface and the 48" surface also matching the 30" deep.

Conference End Transitional Worksurface

The Conference End Worksurface is 42" in diameter with a single 3" diameter steel tubular leg. The top is available with 2mm PVC or flat vinyl T-edge. The worksurface attaches to the end of a 29" high, 30" deep worksurface.

Peninsula Transitional Worksurface

Peninsula Worksurfaces are available 29" high, 30" deep by 48", 60" or 72" wide with flat vinyl T-edge. They include a 3" diameter steel tubular leg and hardware to install in the mounting configuration specified; end, side or center mounted. Side and Center Mount Peninsula Worksurfaces have modesty panels. A wire management port is located in the center at the top of each modesty panel.

Worksurface Planning

TRANSITIONAL WORKSURFACES CONT...

Transitional Worksurfaces make the transition around corners and rely on fixed height Basic Worksurfaces for their support.

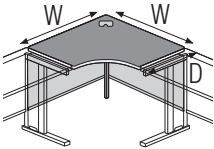
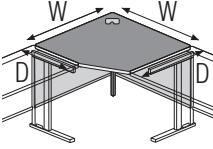
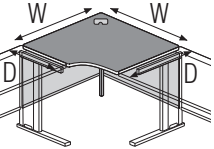
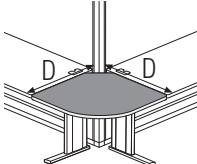
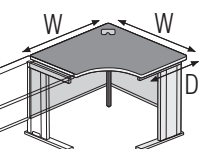
	Corner Curvilinear	Corner Reduction	Corner Curved Reduction	Quarter Round for use with Panels	End-of-Run Curvilinear
	36", 42", or 48" Wide x 24" Deep 42" or 48" Wide x 30" Deep	42" Wide x 24" or 30" Deep 48" Wide x 24" or 30" Deep	42" Wide x 24", 30" Deep 48" Wide x 24", 30" Deep	24" Deep 30" Deep	36", 42", 48" Wide x 24" Deep 42", 48" Wide x 30" Deep
					
Heights:					
29" to 29"	■	■			
29" to 27"	■	■			
27" to 27"	■	■			
27"			■	■	■
29"			■	■	■
Edges:					
2mm	■	■	■	■	■

Corner Transitional Curvilinear Surface

Corner Transitional Curvilinear Surfaces have the same basic construction and features as the Corner Transitional Surface except for the radiused front edge. Corner Transitional Curvilinear Surfaces are available in five sizes: 36", 42" and 48" wide x 24" deep or 42" and 48" wide x 30" deep.

Corner Transitional Reduction Surface

Corner Transitional Reduction Surfaces have the same basic construction and features as the Corner Transitional Surface except that the depth of the worksurface is 24" deep on one side and 30" deep on the opposite end. Available in 42" and 48" wide. Reduction Surfaces have a meaningful part number which indicates the dimensions of the worksurface. For example: a reduction surface that is 30" deep on the left as you face the worksurface, 48" wide and 24" deep on the right would have the dimensions included in the part number in order from left-to-right, 304824.

Corner Transitional Curvilinear Reduction Surface

Corner Transitional Curved Reduction Surfaces have the same basic construction and features as the Corner Transitional Curvilinear Surface except that the depth of the

worksurface is 24" deep on one side and 30" deep on the opposite end. Available in 42" and 48" wide. Reduction Surfaces have a meaningful part number which indicates the dimensions of the worksurface. For example: a reduction surface that is 30" deep on the left as you face the worksurface, 48" wide and 24" deep on the right would have the dimensions included in the part number in order from left-to-right, 304824.

Quarter Round Transitional Surface for use with Panels

The Quarter Round Transitional Surface is available in styles for mounting around System XXI panels when worksurfaces are backed up to panels. Because of their size and application, they do not have modesty panels.

End of Run Corner Transitional Curvilinear Surface

End of Run Corner Transitional Curvilinear Surfaces have the same construction and features as the End of Run Corner Transitional Surfaces except for the radiused front edge. They are available in 36", 42" and 48" widths for use with 24" deep fixed height Basic Worksurfaces and 42" and 48" wide for use with 30" deep fixed height Basic Worksurfaces.

Worksurface Planning

MOBILE TABLES

FlexStation offers added flexibility to your workstation layout with the addition of Mobile Tables.

Mobile Teardrop

40" Diameter x 24" Deep
50" Diameter x 30" Deep

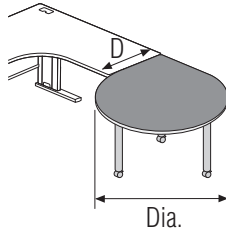

Mobile Semi-Circle

48" Diameter x 24" Radius x 24" Deep
60" Diameter x 30" Radius x 30" Deep

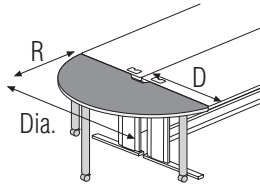

Mobile Semi-Circle for use with Panels

51.5" Diameter x 25.75" Radius x 24" Deep
63.5" Diameter x 31.75" Radius x 30" Deep

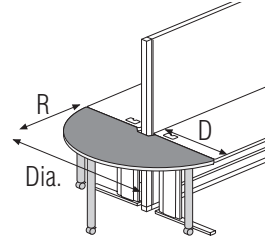

Height:

29"



Edges:

2mm



Mobile Teardrop Table

Mobile Teardrop Tables have 1.25" solid core tops with high-pressure laminate surface edged with 2mm PVC edging. Tops are supported with three, 3" tubular legs with adjustable chrome-plated glides or optional dual-wheel casters. Two of the three casters are lockable. Tables are available 29" high only. Teardrop Tables are made to fit into a corner or end application to match a 24" or 30" deep worksurface. Tables may be used freestanding or grouped together to form team tables.

Mobile Semi-Circle

Mobile Semi-Circle Tables have the same features and construction as the Teardrop Table. Semi-Circle Tables are available in 48" diameter for placement at the end of two 24" deep worksurfaces placed back-to-back and 50.5" diameter for two 24" deep worksurfaces placed back-to-back with a System XXI panel between. 60" diameter tables are available for 30" deep worksurfaces and 62.5" diameter for 30" deep worksurfaces separated by a panel. All Mobile Semi-Circle Tables have a wire management notch at the center of the straight side. Tables may be grouped together to form team tables.

Worksurface Planning

FLEXSTATION WITH POWERUP®

PowerUp is a three-part system that consists of a Power/Data Module, a Wire Management System and a Ten-Wire Six-Circuit Electrical Distribution System. PowerUp is offered in various combinations of the parts to custom tailor a workstation. PowerUp is offered with Basic Rectangular Worksurfaces and Rectangular Adjustable Keyboard Pad Worksurfaces.

The Wire Management System

- The Wire Management System attaches under the worksurface between the table legs. It has a data door that conceals a steel divider that separates power and data cables, a table-to-table steel wireway, a splice plate and notched vertical wireways on the legs to pass cables through to the next table.

The Ten-Wire Six-Circuit Electrical Distribution System

- The Ten-Wire Six-Circuit Electrical Distribution System attaches to the underside of the worksurface. The 30" to 54" wide worksurface harness accommodates two 15 amp duplex receptacles and the 60" and 72" wide worksurface harness can accommodate up to four duplex receptacles.
- Receptacles are available to access the six circuits within the harness and must be ordered separately. They are marked for the circuit they will access. Circuits 1, 2 and 3 are convenience circuits and share a common neutral and ground. They are black in color. Circuits 4i, 5i and 6i are used as isolated circuits and have their own neutral and ground. They are easily identified by their orange color.
- Power is supplied to the distribution harness from a floor or wall source with the Floor Power Infeed Kit. The kit includes 6' of plastic covered flexible metal conduit with a 1/2", 90° waterproof connector. Two steel covers are included to replace the existing plastic vertical wireways in the table leg. The Infeed Kit brings power through the table leg and attaches to the connector at the end of the distribution harness. When tables are used in a run and power is being transferred from table-to-table, the Infeed Kit must be placed at either end of the run.

The PowerUp system occupies space at the back of each worksurface, restricting the amount of room available for hanging or placing pedestals under the worksurface. The following list is the recommended pedestal usage for FlexStation Worksurfaces:

- 24" Deep x 29" High Worksurface
 - Hanging Not recommended.
 - Mobile Recommended maximum depth pedestal of 17⁵/₈".
 - Freestanding Recommended maximum depth of 21⁵/₈".
- 24" Deep x 27" High Worksurface
 - Hanging Not recommended.
 - Mobile Recommended maximum depth pedestal of 17⁵/₈".
 - Freestanding Not recommended.
- 30" Deep x 29" High Worksurface
 - Hanging Recommended maximum depth pedestal of 17⁵/₈".
 - Mobile Recommended maximum depth pedestal of 17⁵/₈".
 - Freestanding Recommended maximum depth pedestal of 27⁵/₈".
- 30" Deep x 27" High Worksurface
 - Hanging Recommended maximum depth pedestal of 17⁵/₈".
 - Mobile Recommended maximum depth pedestal of 17⁵/₈".
 - Freestanding Not recommended.

Worksurface Planning

Figure 1

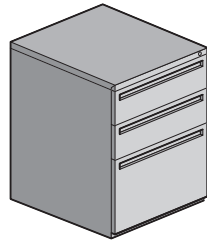

Freestanding

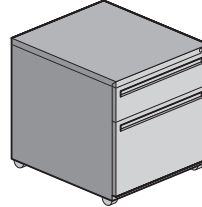

Mobile

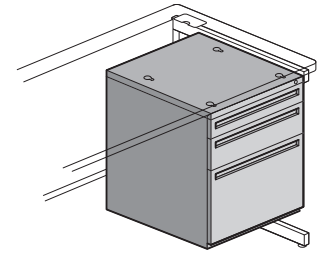

Hanging

PEDESTAL STORAGE

Pedestal Storage for FlexStation is provided with Series XXI Pedestals. Three styles are available to meet personal storage requirements: Freestanding, Mobile and Hanging pedestals (Figure 1).

Pedestals are available in three depths; 17 $\frac{1}{8}$ " that may be used with any depth worksurface, 21 $\frac{1}{8}$ " for maximum storage under a 24" worksurface and 27 $\frac{1}{8}$ " for use under 30" worksurfaces. Worksurfaces are predrilled to accept any style Hanging Pedestal.

NOTE: To allow for clearance to the Wire Management System on PowerUp worksurfaces, specific sizes and styles of pedestals must be used. Refer to chart under FlexStation with PowerUp for the correct usage.

The 12" file and 15" EDP drawer sizes have full extension slide arm suspensions for full access to storage space. The 3" pencil drawers and 6" box drawers have three-quarter extension, steel ball-bearing suspension.

Locks are included in each pedestal and are random keyed. Specific keying combinations are available at no charge, but must be included with the original order.

Freestanding Pedestals

Freestanding pedestals have a finished top and four adjustable glides. They may be placed under a FlexStation worksurface or anywhere else in the office. A Counterbalance Weight (not included) is recommended when freestanding units are not placed under worksurfaces.

Mobile Pedestals

Mobile pedestals have a finished top and four twin-wheel hooded casters. Front casters are locking and back casters are non-locking. A Counterbalance Weight is included with each unit. Mobile pedestals may be placed under a FlexStation worksurface or anywhere else in the office.

Hanging Pedestals

Hanging pedestals have keyhole slots for attachment under FlexStation Basic Worksurfaces.

Worksurface Planning

CENTER DRAWER

Center Drawers are formed steel construction with a molded plastic compartment tray. Locks are included and are random keyed. Specific keying combinations are available at no charge, but must be included with the original order. They attach under Basic FlexStation Worksurfaces and are available in the five trim colors (Figure 3).

Figure 3

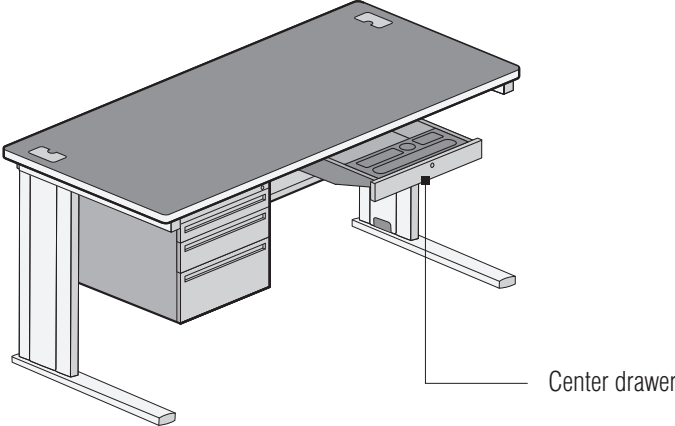

LATERAL FILES

To provide high volume filing in a FlexStation workstation, Series XXI Lateral Files can be used, EDP Media Units and Cupboards. These units match the Series XXI Pedestals in appearance and are available in a wide range of sizes to meet any filing need. See the Series XXI Filing and Storage Product Offering Catalog for a complete product offering (Figure 4).

Figure 4

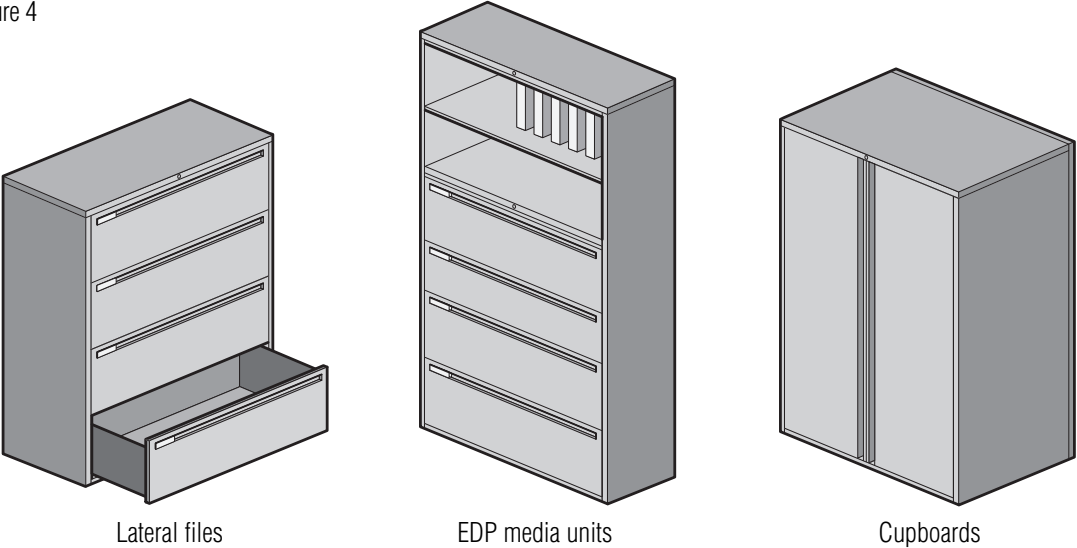

FlexStation offers a full range of accessories to facilitate the use of computers in the workstation.

Worksurface Planning

WORKSURFACE ACCESSORIES

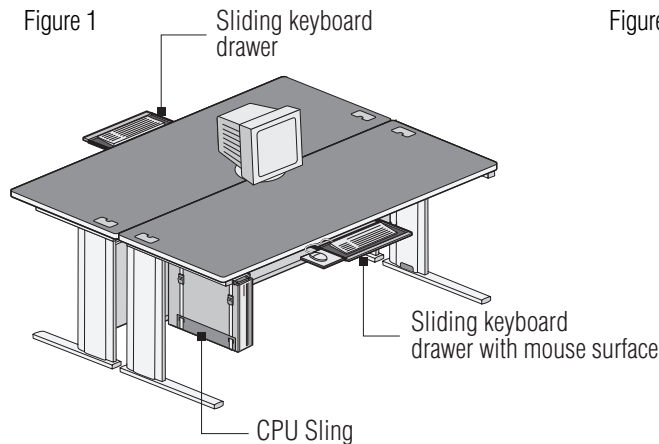

Sliding Keyboard Drawer

Sliding Keyboard Drawers attach to the underside of rectangular single surface worksurfaces and Basic Corner, Transitional Corner and End of Run Worksurfaces that are 42" wide x 24" deep or larger. The Sliding Keyboard Drawer has 16" steel ball bearing slides with height adjustments at 3", 3½" and 4" below the worksurface. Available in the four trim colors, they accommodate keyboards up to 9" by 22" on a non-skid surface and will accept the Optional Wrist Rest (Figure 1).

Sliding Keyboard Drawer with Mouse Surface

Sliding Keyboard Drawer with Mouse Surface attaches to the underside of rectangular single surface worksurfaces and Basic Corner, Transitional Corner and End of Run Worksurfaces that are 42" wide x 24" deep or larger. They have 16" steel ball bearing slides with height adjustments at 3", 3½" and 4" below the worksurface. They accommodate keyboards up to 9" by 22" on a non-skid surface and will accept the Optional Wrist Rest. The mouse surface extends to the left or right and provides a 9¼" wide by 9" deep surface. They are available in black only.

Fully Adjustable Keyboard Tray

Fully Adjustable Keyboard Trays attach to the underside of Basic corner or rectangular worksurfaces and Transitional corner worksurfaces. They feature a 5½" vertical adjustment, 359° swivel and a tilt range of 15° positive and 15° negative. The keyboard tray slides back to store below the worksurface. The non-skid surface accommodates keyboards up to 9" by 22". They are available in the four trim colors (Figure 2).

Optional Wrist Rest

The Optional Wrist Rest fits the Sliding Keyboard Draw, Sliding Keyboard Draw with Mouse Surface and Fully Adjustable Keyboard Tray to provide additional wrist support. They are available in black only (Figure 2).

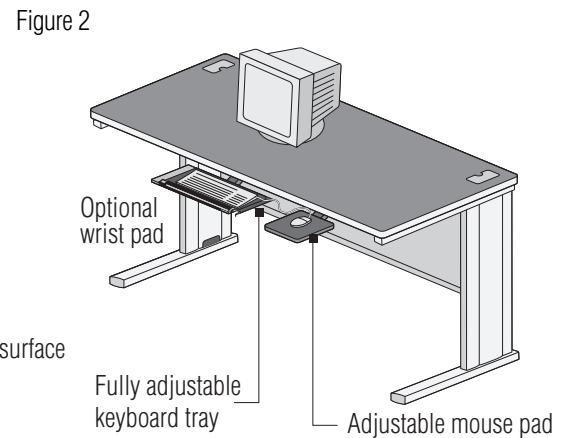

CPU Sling

The CPU Sling is designed for use with Basic Rectangular Worksurfaces only. It attaches to the underside of rectangular worksurfaces and accommodates a range of CPU's up to 65" in circumference and a maximum of 75 pounds. It provides 5½" of front-to-back travel and 359° swivel for ease of accessibility. The CPU Sling is black only (Figure 1).

Adjustable Mouse Pad

Adjustable Mouse Pads attach to the underside of FlexStation Worksurfaces. They feature a 5½" vertical adjustment, 359° swivel and slide under the worksurface for storage. They have a neoprene surface and are available in black only (Figure 2).

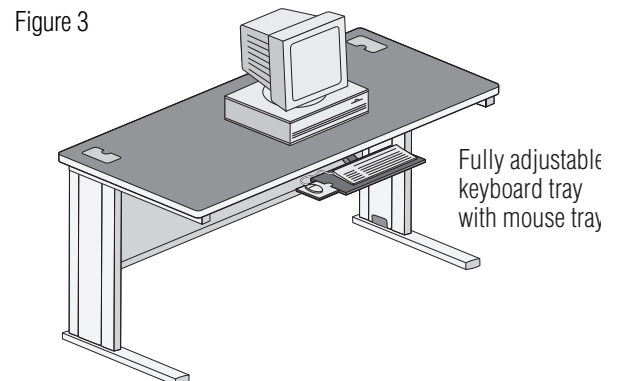

Fully Adjustable Keyboard Tray with Mouse Tray

Fully Adjustable Keyboard Tray with Mouse Tray attaches to the underside of Basic corner or rectangular worksurfaces and Transitional corner worksurfaces. They feature a 5½" vertical adjustment and a tilt range of 15° positive and 15° negative. The keyboard tray swivels 359° and retracts to store below worksurface. The non-skid surface accommodates keyboards up to 9" by 22" and the mouse tray extends 9½" to the left or right. They are available in black only (Figure 3).

FlexStation Overhead Storage

OVERHEAD STORAGE (FLIPPER DOOR)

FlexStation offers three styles of laminate side overhead storage units for use with Basic Rectangular Worksurfaces. They are available as a flipper door unit, a flipper door on one half and an open shelf on the other in 60" and 72" widths, or as open shelves. Overhead units must match the width of the worksurface it is to be used with. Overheads for Basic Rectangular Worksurfaces attach through the grommets in the top of the worksurface. They have vertical wire channels that conceal the attachment and wires from the top of the shelf to the worksurface. Overhead cabinets are 34" high and have 18½" clearance between the worksurface and the bottom of the shelf. The flipper door opening is 13" high.

Figure 1

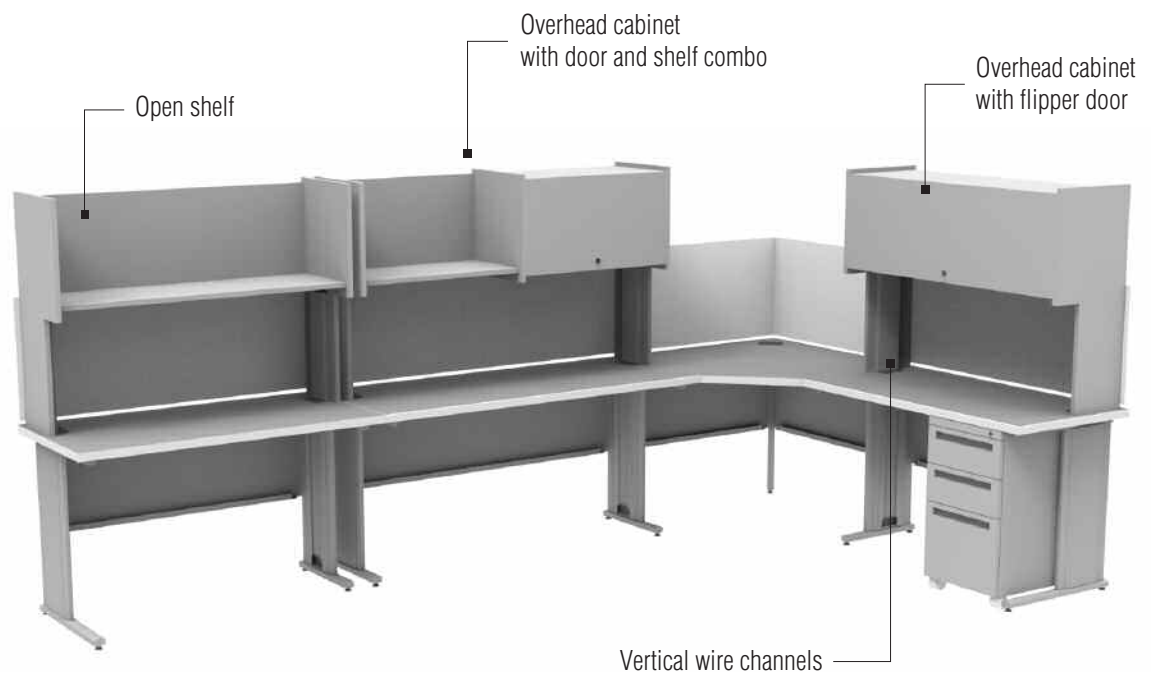

Overhead Cabinet with Flipper Doors

Overhead Cabinets with Flipper Doors have solid core construction for backs and end panels with high-pressure laminate finishes, edges are finished with flat vinyl edge. Doors are available with high-pressure laminate or fabric surface and are random keyed or can be keyed-alike to match other overheads or pedestals. Key-alike items must be identified on your order. Units measuring 30" to 48" wide have a single door, while 54", 60" and 72" units have two doors.

Overhead with Door and Shelf Combo

Overhead with Door and Shelf Combo have the same construction and features as the flipper door units, except are available with a door on one side and an open shelf on the other. Units are available in 60" and 72" widths only. Door position must be specified left or right.

Open Shelf

Open Shelves have the same construction as Flipper Door Cabinets only with open shelves. Units are available in the full range of sizes, 30" to 72" wide.

FlexStation Overhead Storage

OVERHEAD STORAGE (UNIVERSAL & VENUS)

Universal and Venus® Overhead Cabinets

Overhead storage shall consist of the Venus® overhead and Universal overhead and shelves. Overhead storage shall attach to worksurface with two or three overhead support stanchions, depending on size. 30", 36", 42", 48", 54", 60" and 72" sizes shall be available. 66" overheads shall consist of a 30" and 36" overhead combination. 72" overheads shall consist of a pair of 36" overheads.

Shelf dividers shall be powder-coated steel with installation and removal accomplished without the use of tools or fasteners.

Universal overheads and shelves shall be 17" high and shall have 19-1/2" clearance between the worksurface and the bottom of shelf. Overhead doors shall be available with painted steel, fabric, laminate, or veneer, with a PVC extrusion handle. Locks shall be randomly assigned or keyed per customer requests.

The end panels shall be constructed of 14-gauge steel and have self-locking mounting tabs formed into the back edge. The shelf, back, and top shall be constructed from 18-gauge steel. The front edge of the shelf shall be a PVC extrusion that also provides space for a concealed flush mount task light.

Venus® overheads shall be 17" high and have 19-1/2" clearance between the worksurface and the bottom of shelf. The upper door shall be available in colored or translucent extruded rigid PVC with spatter-coat finish, fabric, or laminate applied. The overall door thickness shall be 3/8". The lower door shall be an aluminum extrusion and be ergonomic in design. A center lock mechanism shall be utilized between the upper and the lower doors for security.

The overhead doors shall be effortlessly operated from either a seated or standing position through use of the upper or lower door. The upper door and lower door shall be synchronized in motion through the use of two 10-gauge linkages. The doors shall be assisted with two extension springs and require less than 5 pounds of force to operate. The upper door shall open over the outside of the case.

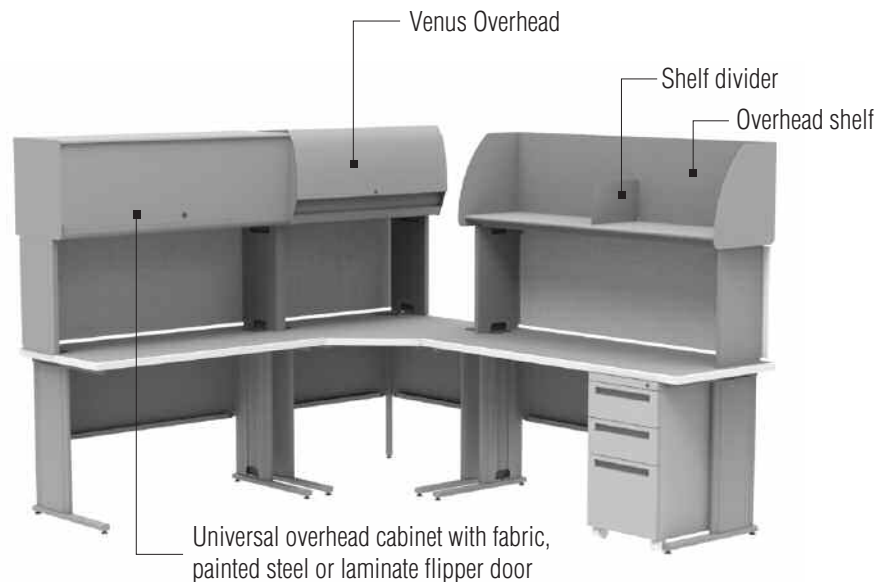

Steel Overhead Cabinets

Steel Overhead Cabinets are available with a choice of flipper doors; Enamel coated steel front, Fabric laminated steel front or High-pressure laminate over particleboard core. Units are available 30", 36", 42", 48", 54" and 60" wide with a single door. The 72" units consist of two 36" doors. Shelves are slotted for positive attachment of optional shelf dividers.

Steel Overhead Shelves

Steel Overhead Shelves are available in the full range of sizes; 30" to 72" wide. The 72" wide shelves consist of two 36" wide shelves with a middle support bracket. Shelves are slotted for positive attachment of optional shelf dividers.

FlexStation Overhead Storage

OVERHEAD STORAGE ACCESSORIES

FlexStation offers a full range of accessories for use with overhead storage units. Task lights provide illumination for the worksurface and a paper management system adds organization to the area above the worksurface.

Task Lights

Task Lights shall be offered as an energy efficient electronic ballast task light. The energy efficiency model shall have an electronic ballast with rapid start, cool-white T-8 fluorescent lamp.

Task Lights shall attach to the underside of the shelf on overhead cabinets. Lights shall be UL Listed and available in black only. They shall be available 24" wide for use with 24", 30" and 36" wide overhead cabinets, 36" wide for 42" and 48" wide units, and 48" wide for 60", 66" and 72" wide units.

Specify (2) 24" on 72" Universal or Venus overheads,
18" wide for 24" overhead
24" wide for 30" and 36" overheads,
36" wide for 42" and 48" overheads,
48" wide for 54" and 60" overheads.

FlexStation Overhead Storage

PAPER MANAGEMENT

The Paper Management System addresses the storage and movement of files, binders and documents. Components are available with integrated hooks for attachment to the Tool Rail. The system is available in the five trim colors (Figure 2).

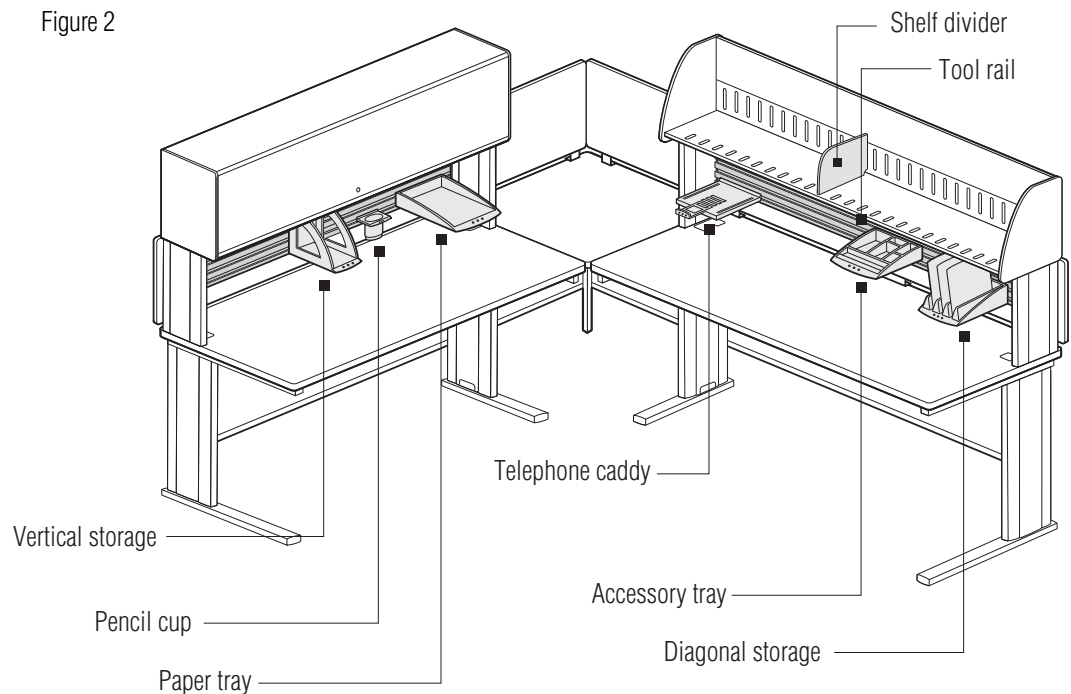

Tool Rail

Aluminum extrusion tool rail, powder-coated finish. Attaches between overhead uprights. Consists of four slots to accept paper management components. To be used on WZUS, WZUF, WZUL, WUSS, VNOS, VNOL and VNOF models.

Paper Tray

Constructed of injection molded plastic. Tray measures 9-1/2" wide by 2" high by 14" deep and accommodates both letter and legal size documents. Includes three hooks to mount on tool rail.

Vertical Storage

Constructed of injection molded plastic. Holder measures 5" wide by 9" high and 10-1/2" deep. Includes two hooks to mount on tool rail.

Pencil Cup

Constructed of injection molded plastic. Cup measures 4" wide by 3" high by 3-1/2" deep for storage of pens, pencils and highlighters. Includes one hook to mount on tool rail.

Diagonal Storage

Constructed of injection molded plastic. Storage tray consists of three diagonal slats with black dividers to sort files or papers. Tray measures 7" wide by 2-1/2" high by 12-1/2" deep and includes three hooks to mount on tool rail.

Telephone Caddy

Constructed of injection molded plastic. Caddy measures 8-1/2" wide by 2" high by 9-1/2" deep. Includes adjustable rail to accommodate a phone up to 10-3/4" deep. Includes three hooks to mount on tool rail.

Accessory Tray

Constructed of injection molded plastic. Holder measures 9-1/2" wide by 2" high by 10" deep and includes three hooks to mount to tool rail. Tray includes six compartments for storage of supplies.

FlexStation Privacy Screens

PRIVACY SCREENS

Privacy Screens provide sit-down privacy within the FlexStation workstation. Screens are 19" high and available in widths to fit all Basic and Transitional Worksurfaces, straight, corner, with or without keyboard pad.

Screens are fabric covered and can be used as a tackable surface. The fabric surface on both sides allows one set of screens to serve two worksurfaces placed back-to-back. Privacy Screens can be used on worksurfaces with Overhead Storage Units to close the opening between the worksurface and the bottom of the shelf. Screens include mounting brackets and alignment plates to provide secure mounting. Corner screens include a corner alignment plate. Screens are available in configurations to match the worksurface application, Basic Worksurface, Corner Worksurface or Transitional Worksurface (Figure 1).

Mounting brackets are available in the WZP and WZAP styles. The WZP bracket is constructed of formed steel while the WZAP bracket is constructed of extruded aluminum and attached to a steel plate. The WZAP bracket should be used when more rigidity is required.

Figure 1

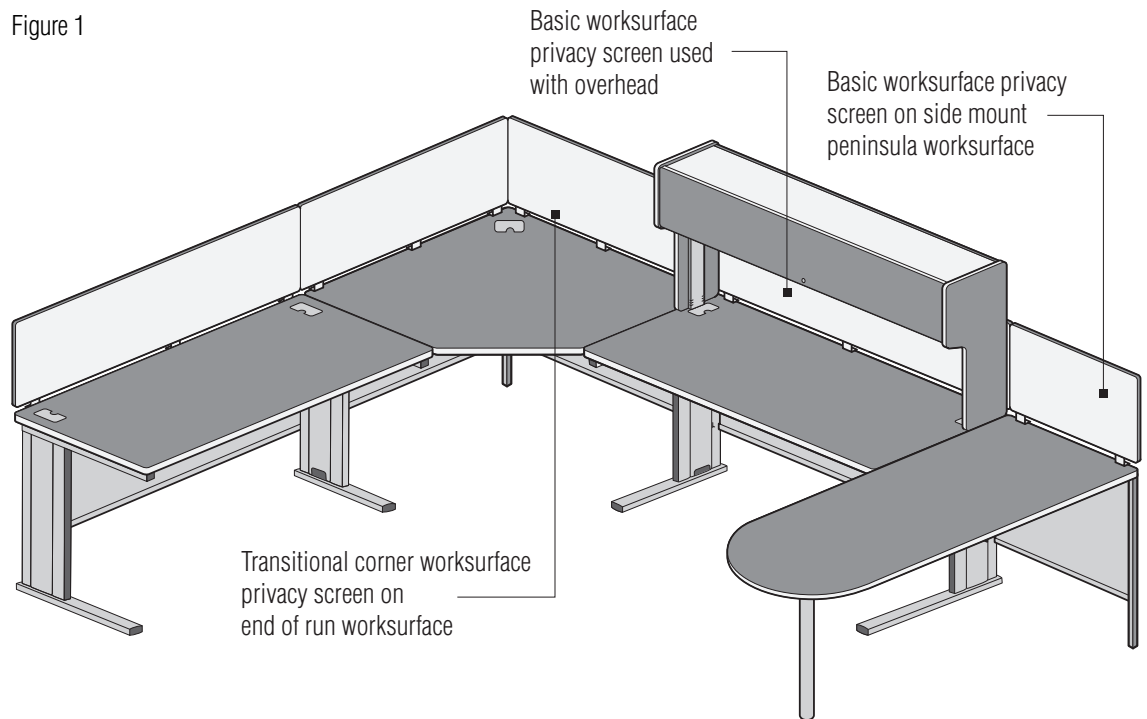

Basic Worksurface Privacy Screens

Basic Worksurface Privacy Screens are designed for straight line applications. They include mounting brackets for attachment to the worksurface and a full-height, steel splice plate to align adjoining screens. Screens are available for straight applications in 24", 30", 36", 42", 48", 54", 60", 66" and 72". The 60" and 72" consist of a pair of screens, two 30" and two 36" with splice plates.

Corner Worksurface Privacy Screens

Corner Worksurface Privacy Screens are available as a pair of screens to enclose the corner. They have a 90° splice plate to align the screens. Corner screens are available for 36", 42" and 48" corner worksurfaces. If the application requires only one side of the corner to have a screen, you may specify a straight 36", 42" or 48" screen to match the length required.

Transitional Worksurface Privacy Screens

Transitional Worksurface Privacy Screens are offered in sizes and combinations of screens to enclose the corner occupied by a particular transitional worksurface, corner, square, rectangle and triangle. The End of Run Transitional Worksurface uses a corner screen if both sides are to be screened or specify a straight screen to match just one side. To screen the width of a Peninsula Worksurface used in a side or center mount application you would specify a 30" straight screen.

FlexStation Design Review

WORKSURFACES

The layout and design of a FlexStation workstation is the same as any other system furniture. You start with the primary worksurface and from there you add secondary and transitional worksurfaces to build the shape of the workstation.

When specifying FlexStation worksurfaces it is important to determine the primary worksurface. All other worksurfaces will be specified based on their relationship to the primary worksurface. The primary worksurface is the major work area and is determined by its size, height, width and depth to be the largest worksurface in the workstation. Special attention should be taken in specifying the worksurfaces. The unique ability to specify the type and placement of the worksurface legs adds flexibility to the workstation. The following workstation layouts show how to specify the most common applications and where to specify transitional legs:

Figure 1

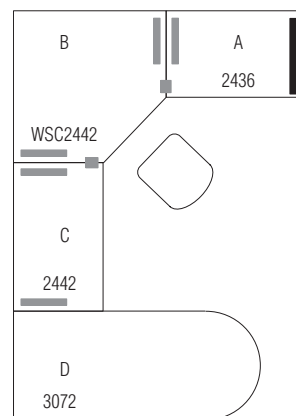

Figure 1 shows a workstation with all the same height worksurfaces and is specified as follows:

- A) Basic worksurface 24" deep x 36" wide with a left transitional leg
- B) Freestanding corner 24" deep x 42" wide with both transitional legs
- C) Basic worksurface 24" deep x 42" wide with both transitional legs
- D) A side mount Peninsula worksurface

Note: Transitional Worksurfaces are furnished with splice plates. When utilizing transitional legs on Basic Freestanding Worksurfaces that are adjoining, optional splice plates are required to add support and attach tables together.

Figure 2

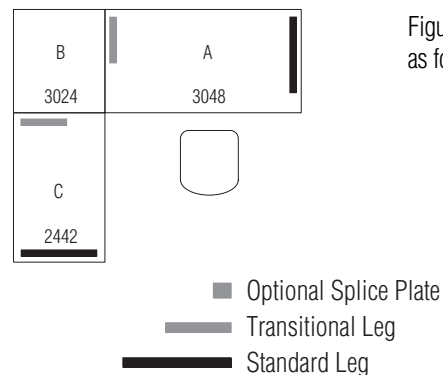

Figure 2 is a workstation with all the same height worksurfaces and is specified as follows:

- A) Primary basic worksurface 30" deep x 48" wide with a left transitional leg
- B) Rectangle Transitional Worksurface with left transition direction due to being positioned to the left of the primary worksurface
- C) Basic worksurface 24" deep x 42" wide with a right transitional leg

Figure 3

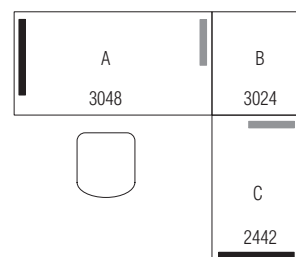

Figure 3 is the right-hand version of Figure 2 and would be specified as follows:

- A) Primary basic worksurface 30" deep x 48" wide with a right transitional leg
- B) Rectangle Transitional Worksurface with right transition direction due to being positioned to the right of the primary worksurface
- C) Basic worksurface 24" deep x 42" wide with a left transitional leg

FlexStation Design Review

WORKSURFACES

Figure 4

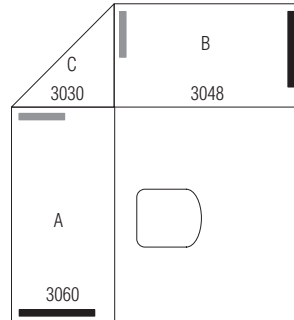

Figure 4 is a workstation with all the same height worksurfaces and is specified as follows:

- A) Primary basic worksurface 30" deep x 60" wide with a right transitional leg
- B) Basic worksurface 30" deep x 48" wide with a left transitional leg
- C) Triangle Transitional Worksurface with no transition direction needed to be specified

Figure 5

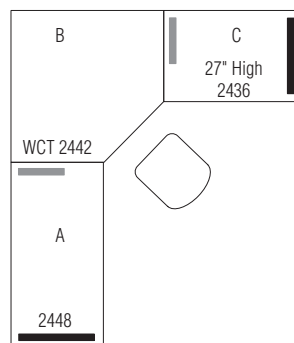

Figure 5 is a workstation with different height worksurfaces and is specified as follows:

- A) Primary basic worksurface 24" deep x 48" wide x 29" high with a right transitional leg
- B) Corner Transitional Worksurface with right transition direction due to being positioned to the right of the primary worksurface and is also specified with a "97" to signify the drop from 29" to 27" in height
- C) Basic worksurface 24" deep x 36" wide x 27" high with a left transitional leg



Figure 6

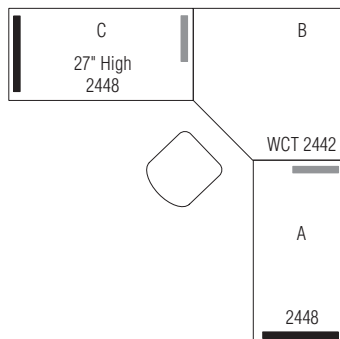

Figure 6 is the right-hand version of Figure 5 except the Basic Rectangular Worksurfaces are the same size but different heights and would be specified as follows:

- A) Primary basic worksurface 24" deep x 48" wide x 29" high with a left transitional leg
- B) Corner Transitional Worksurface with left transition direction due to being positioned to the left of the primary worksurface and is also specified with a "97" to signify the drop from 29" to 27" in height
- C) Basic worksurface 24" deep x 48" wide x 27" high with a right transitional leg

FlexStation Specifications

BASIC WORKSURFACES

Worksurfaces shall define the shape of the workstation and provide support for overhead storage, hanging pedestals, electrical componentry and privacy screens. Worksurfaces shall be designed to integrate function and ergonomics to provide solutions that meet ANSI/HFS 100-1988 and ADA user requirements.

Worksurface tops shall be 1¼" solid core with high-pressure laminate surface, available in a choice of various colors. The laminate on Corner and Keyboard Corner Worksurfaces shall run diagonally, paralleling the front edge. Tops shall be available with 2mm PVC edge in a choice of five edge colors, or post-formed laminate front with flat P.V.C. self-edging on side and rear edges to match the top color.

Worksurfaces shall be supported by a heavy-gauge, seam-welded tubular steel frame and two welded steel legs joined by a steel modesty panel, full modesty panel or beam option. Legs and modesty panels shall be color matched and available in various trim colors. Internal 2 pc PVC vertical raceways shall be located on the inside of each leg to provide for easy wire management from the floor to the worksurface. Legs shall be equipped with adjustable chrome-plated glides to compensate for uneven floors. Separate caster kits shall be available that include four casters, two with locks. Casters shall add 2" to the height of the worksurface.

Legs shall be available in two depths, standard and transitional. Transitional legs shall be six inches shorter in depth than the standard leg. This shall allow for more clearance for feet and chair movement where worksurfaces join in a straight line or corner applications.

Rectangular Worksurfaces

Basic Rectangular Worksurfaces shall include two wireway grommets, located in the back corners of each worksurface. Grommets shall be color matched to the worksurface laminate trim color. An optional wireway for wire management shall be located behind the top of the modesty panel.

Worksurfaces shall be available in 30", 36", 42", 48", 54", 60", 66" and 72" widths and 24" and 30" depths. They shall be available in 27" and 29" heights.

Stand-up Worksurface

Stand-up Worksurfaces shall have the same features as the rectangular worksurface, but shall be available in one size; 30" deep by 36" wide by 42" high with the standard depth legs.

Stand Alone Corner Worksurface

Stand Alone Corner Worksurfaces shall have the same basic construction as the rectangular worksurfaces. The Stand Alone Corner Worksurface shall be used where a freestanding corner worksurface is needed. Worksurfaces shall be available 36", 42" or 48" wide by 24" deep and 42" or 48" wide by 30" deep. They shall be available in 27" and 29" heights and include (3) grommets and cutouts for optional corner overhead.

Rectangular Adjustable Keyboard Pad Worksurfaces

Rectangular Adjustable Keyboard Pad Worksurfaces shall have the same construction features as the Basic Worksurface except for the addition of the 10" by 24" keyboard pad. The pads shall have a 3" height adjustment, a tilt range of 15° positive and 15° negative, and 1" forward extension. Worksurfaces shall be available in 30", 36", 42", 48", 54", 60", 66" and 72" widths and 24" and 30" depths. They shall be available in 27" and 29" heights. Rectangular Adjustable Keyboard Pad Worksurfaces are available with the keyboard pad located left, right or center on widths of 48", 54", 60", 66" and 72". The 36" and 42" wide worksurfaces shall be available with the keyboard pad located in the center position only.

Corner Adjustable Keyboard Pad Worksurfaces

Corner Adjustable Keyboard Pad Worksurfaces shall provide a fixed height worksurface with the 10" by 24" adjustable keyboard pad where a freestanding corner worksurface is needed. Worksurfaces shall be available 42" wide by 24" deep and 48" wide by 24" deep or 48" wide by 30" deep. The corner worksurface shall be available with 27" and 29" high standard depth legs.

FlexStation Specifications

Stand Alone Corner Curvilinear Worksurface

Stand Alone Corner Curvilinear Worksurfaces shall have the same basic construction as the rectangular worksurfaces. The Stand Alone Corner Curvilinear Worksurface shall be used where a freestanding corner worksurface is needed to continue a radiused front edge around a corner between same depth worksurfaces. Worksurfaces shall be available 36", 42" or 48" wide by 24" deep and 42" wide by 30" deep. They shall be available in 27" and 29" heights.

Stand Alone Corner Reduction Worksurface

Stand Alone Corner Reduction Worksurfaces shall have the same basic construction as the Stand Alone Corner Worksurfaces. The Stand Alone Corner Reduction Worksurfaces shall be used where a freestanding corner worksurface is needed to accommodate a 30" deep worksurface on one side and a 24" worksurface on the other side. Worksurfaces shall be available in 42" or 48" wide. They shall be available in 27" and 29" heights.

Stand Alone Corner Curvilinear Reduction Worksurface

Stand Alone Corner Curvilinear Reduction Worksurfaces shall have the same basic construction as the Stand Alone Corner Reduction Worksurfaces. The Stand Alone Corner Curvilinear Reduction Worksurfaces shall be used where a freestanding corner worksurface is needed to accommodate a radius from a 30" deep worksurface on one side and a 24" worksurface on the other side. Worksurfaces shall be available in 42" or 48" wide. They shall be available in 27" and 29" heights.

Curvilinear Worksurface

Curvilinear Worksurfaces shall have the same basic construction as the rectangular worksurfaces except the front edge shall make a curved reduction from 30" deep to 24" deep. Worksurfaces shall be available 42", 48", 54", 60", 66" and 72" wide. They shall be available in 27" and 29" heights.

"P" Shaped Peninsula Worksurfaces

"P" Shaped Peninsula Worksurfaces shall have the same basic construction as the rectangular worksurfaces except the front edge shall make an extended "P" shaped peninsula. Worksurfaces shall be available 24" deep by 48" wide by 60", 66" or 72" long, and 30" deep by 48" wide by 66" or 72" long. They shall be available in 27" and 29" heights.

Piano Peninsula Worksurfaces

Piano Peninsula Worksurfaces shall have the same basic construction as the rectangular worksurfaces except the front edge shall make an extended Piano shaped peninsula. Worksurfaces shall be available 24" deep by 48" wide by 60", 66", 72" or 84" long, and 30" deep by 48" wide by 66", 72" or 84" long. They shall be available in 27" and 29" heights.

Square Shoe Peninsula Worksurfaces

Square Shoe Peninsula Worksurfaces shall have the same basic construction as the rectangular worksurfaces except the front edge shall make an extended Square Shoe shaped peninsula. Worksurfaces shall be available 24" deep by 48" wide by 60", 66" or 72" long, and 30" deep by 48" wide by 66" or 72" long. They shall be available in 27" and 29" heights.

TRANSITIONAL WORKSURFACES

Transitional Worksurfaces shall be available to connect two Basic Worksurfaces together to form a corner, or to end a run of Basic Worksurfaces. Transitional Worksurfaces shall make the transition around corners and rely on fixed height Basic Worksurfaces for their support.

Transitional Worksurfaces shall have full wrap modesty panels and 1¼" solid core tops with high-pressure laminate surface. Hardware shall be included for attachment to adjoining worksurfaces for the condition specified. For same height installations, two splice plates shall be provided; for 29" to 27" installations, a splice plate and "Z" bracket shall be provided.

Corner Transitional Worksurface

Corner Transitional Worksurfaces shall be available in three sizes: 36", 42" or 48" wide by 24" deep and 42" or 48" wide by 30" deep. They shall be available in 29" to 29", 29" to 27" and 27" to 27" heights. They shall include a ⅞" square tubular corner support leg with a stainless steel adjustable glide and full wrap modesty panels with wire management ports located in the top center of each panel. Transitional tops shall attach to fixed height Basic Worksurfaces at the worksurface. The modesty panels shall attach to the legs of the adjoining Basic Worksurface to provide a full wrap finished appearance. Tops shall be available in the same construction and finishes as Basic Worksurfaces and shall include one grommet located in the back corner.

FlexStation Specifications

Corner Keyboard Pad Transitional Worksurface

Corner Keyboard Pad Transitional Worksurfaces shall have the same construction and features as the Corner Transitional Worksurface with the addition of the 10" by 24" keyboard pad. The pads shall have a 3" height adjustment, a tilt range of 15° positive and 15° negative, and 1" forward extension. Worksurfaces shall be available in two sizes: 42" or 48" wide by 24" deep and 48" wide by 30" deep. They shall be available in 29" to 29", 29" to 27" and 27" to 27" heights.

Square Transitional Worksurface

Square Transitional Worksurfaces shall be available as 24" or 30" square units and shall be used with matching depth fixed-height Basic Worksurfaces to fill in a corner. Worksurfaces shall include a $\frac{7}{8}$ " square tubular corner support leg with a stainless steel adjustable glide and full wrap modesty panels with wire management ports located in the top outside corner of each panel.

Rectangle Transitional Worksurface

Rectangle Transitional Worksurfaces shall be 24" by 30" and used to match a 24" deep fixed height Basic Worksurface with a 30" deep worksurface at a corner. Worksurfaces shall include a $\frac{7}{8}$ " square tubular corner support leg with a stainless steel adjustable glide and full wrap modesty panels with wire management ports located in the top outside edge of each panel.

End of Run Transitional Worksurface

End of Run Transitional Worksurfaces shall be available in three sizes: 36" by 36", 42" by 42" and 48" by 48". The 36", 42" and 48" worksurface units shall attach to 24" deep worksurfaces and the 48" unit shall attach to 30" deep worksurfaces. Worksurfaces shall include an end support leg, a $\frac{7}{8}$ " square tubular corner support leg with a stainless steel adjustable glide and full wrap modesty panels with wire management ports located in the top center of each panel.

End of Run Transitional Keyboard Pad Worksurface

End of Run Transitional Keyboard Pad Worksurfaces shall have the same construction and features as the End of Run Transitional Worksurface with the addition of the 10" by 24" keyboard pad. The pads shall have a 3" height adjustment, a tilt range of 15° positive and 15° negative, and 1" forward extension. Worksurfaces shall be available in 42" by 42" and 48" by 48" with the 36", 42" and 48" surface matching the depth of a 24" deep fixed-height Basic Worksurface and the 48" surface matching the 30" deep.

Conference End Transitional Worksurface

The Conference End Worksurface shall be 36" or 42" in diameter with a single 3" diameter steel tubular leg. The top shall be available with flat vinyl T-edge only. The worksurface shall attach to the end of a 29" high, 30" deep worksurface.

Peninsula Transitional Worksurface

Peninsula Worksurfaces shall be available 29" high, 24" or 30" deep by 48", 60" or 72" wide with flat vinyl T-edge. Worksurfaces shall include a 3" diameter steel tubular leg and hardware to install in the mounting configuration specified; end, side or center mounted. Side and Center Mount Peninsula Worksurfaces shall have modesty panels. A wire management port shall be located in the center at the top of each modesty panel.

Corner Transitional Curvilinear Surface

Corner Transitional Curvilinear Surfaces shall have the same basic construction and features as the Corner Transitional Surface except for the radiused front edge. Corner Transitional Curvilinear Surfaces are available in five sizes: 36", 42" and 48" wide x 24" deep or 42" and 48" wide x 30" deep.

Corner Transitional Reduction Surface

Corner Transitional Reduction Surfaces shall have the same basic construction and features as the Corner Transitional Surface except that the depth of the worksurface shall be 24" deep on one side and 30" deep on the opposite side. Surfaces shall be available in 42" and 48" wide.

Corner Transitional Curvilinear Reduction Surface

Corner Transitional Curvilinear Reduction Surfaces shall have the same basic construction and features as the Corner Transitional Curvilinear Surface except that the depth of the worksurface shall be 24" deep on one side and 30" deep on the opposite side. Surfaces shall be available in 42" and 48" wide.

FlexStation Specifications

Quarter Round Transitional Surface for use with Panels

Quarter Round Transitional Surface shall be available in styles for mounting around System XXI panels when worksurfaces are backed up to panels. Because of their size and application, they do not have modesty panels.

End of Run Corner Transitional Curvilinear Surface

End of Run Corner Transitional Curvilinear Surfaces shall have the same construction and features as the End of Run Corner Transitional Surfaces except for the radiused front edge. Surfaces shall be available in 36", 42" and 48" widths for use with 24" deep fixed height Basic Worksurfaces and 42" and 48" wide for use with 30" deep fixed height Basic Worksurfaces.

MOBILE TABLES

Mobile Teardrop Table

Mobile Teardrop Tables shall have 1.25" solid core tops with high-pressure laminate surface edged with 2mm PVC edging. Tops shall be supported with three, 3" tubular legs with adjustable chrome-plated glides or optional dual-wheel casters. Two of the three casters shall be locking. Tables are available 29" high only. Teardrop Tables are made to fit into a corner or end application to match a 24" or 30" deep worksurface. Tables may be used freestanding or grouped together to form team tables.

Mobile Semi-Circle Table

Mobile Semi-Circle Tables shall have the same features and construction as the Teardrop Table. Semi-Circle Tables shall be available in 48" diameter for placement at the end of two 24" deep worksurfaces placed back-to-back and 50.5" diameter for two 24" deep worksurfaces placed back-to-back with a System XXI panel between. 60" diameter tables shall be available for 30" deep worksurfaces placed back-to-back and 62.5" diameter for 30" deep worksurfaces separated by a panel. Tables may be grouped together to form team tables.

FLEXSTATION WITH POWERUP®

PowerUp® Power/Data Module

The power/data module is inserted into a rectangular hole in the worksurface. The module has a flip-up cover and is 6-1/4" long x 3" wide x 2-1/2" high. It has one duplex receptacle (110 volts), dual data access and a power cord with a 3-prong plug. The cord is 108" long when used without 10-wire (NP) system and 22" long when used with 10-wire (T6) tables. Connections for phones, modems, printers and networks can be incorporated into the system, but must be ordered separately by the customer through a third party source. Communications wiring is completed in the field by the customer. Each unit ships with a data plate tree which provides holders for common jacks produced by AT&T, Panduit, and others. Contact Customer Service for more information. The single module is located at the rear right, rear left or center position of the worksurface widths 30" through 54". Two modules are available on 60", 66" and 72" wide rectangular surfaces and are located at the rear left and rear right position of the worksurface.

Data Door

The data door (WT) is constructed of rigid PVC .06 wall thickness with a radius of 2-1/2". The door is 8" deep and 4-1/2" high. It attaches to the underside of the table top. The hanging bracket uses the same hole as the modesty panel and can also be used with WB option. Power and data cables are separated from each other by a 24-gauge steel divider that is 2" high by 2-3/4" deep. There is also space allowed for cord management. Available in black only.

Table-To-Table Wireway

The table-to-table wireway trough is a 16-gauge steel trough that attaches to the underside of the adjoining worksurface. The wireway is 3-3/4" deep by 4-1/4" wide. The wireway routes the 10-wire table-to-table connector and data wires between tables. The wire management trough also includes a splice plate that attaches the front of the adjoining tops together to prevent separation.

10-Wire 6-Circuit Pre-Wired Harness

Single sided, rigid 10-wire harness that holds two duplex receptacles (60", 66" and 72" wide tables provide access for up to four duplex receptacles). Harness contains 6 hot wire, 2 neutral wires and 2 ground wires and is commonly referred to as (6-2-2). The harness has mounting brackets to attach to the underside of the worksurface top with screws. The harness is 2-1/2" wide and the length of the harness varies with the size of the top. Power is obtained by use of the 10-wire Power Infeed Kit. Duplex receptacles are located under the worksurface are specified separately.

FlexStation Specifications

10-Wire Table-To-Table Connector

10-wire table-to-table connector consists of flexible mesh conduit which provides power connections from adjoining tables. The jumper is 17-3/4" long and is routed through the table-to-table wireway.

10-Wire Power Infeed Kit

The 10-wire infeed kit provides power from fixed, floor, or wall sources to the 10-wire harness. It includes six feet of plastic covered flexible conduit, and 3/4" waterproof 90° connector. Also included are two steel covers which replace the existing plastic vertical wireway.

UL Listed

The FlexStation® with PowerUp® System is listed to applicable UL standards and requirements by Underwriters Laboratories, Inc. Two of the standards used to evaluate FlexStation® are UL/286 Office Furnishings and UL/723 Standard for Test for Surface Burning Characteristics of Building Materials. The standard used to evaluate PowerUp® is UL 1363 Relocatable Power Taps.

PEDESTAL STORAGE

Pedestal Storage for FlexStation shall be provided by Series XXI Pedestals. Three styles shall be available to meet personal storage requirements: Freestanding, Mobile and Hanging pedestals.

Pedestals shall be available in three depths; 17⁵/₈" that may be used with any depth worksurface, 21⁵/₈" for maximum storage under a 24" worksurface and 27⁵/₈" for use under 30" worksurfaces.

The 12" file and 15" EDP drawer sizes shall have full extension slide arm suspensions for full access to storage space. The 3" pencil drawers and 6" box drawers shall have three-quarter extension, steel ball-bearing suspension.

Locks shall be included in each pedestal and shall be random keyed. Specific keying combinations shall be available.

Freestanding Pedestals

Freestanding pedestals shall have a finished top and four adjustable glides. They shall be placed under a worksurface or anywhere else in the office. A Counterbalance Weight shall be available for freestanding units when not placed under worksurfaces.

Mobile Pedestals

Mobile pedestals shall have a finished top and four twin-wheel hooded casters. Front casters shall be locking and back casters shall be non-locking. A Counterbalance Weight shall be included with each unit.

Hanging Pedestals

Hanging pedestals shall have keyhole slots for attachment under Basic Worksurfaces.

Center Drawer

Center Drawers shall be formed steel construction with a molded plastic compartment tray. Locks shall be included and shall be random keyed. Specific keying combinations shall be available. They shall attach under Basic FlexStation Worksurfaces and shall be available in various trim colors.

WORKSURFACE ACCESSORIES

FlexStation shall offer a full range of accessories to facilitate the use of computers in the workstation.

Sliding Keyboard Drawer

Sliding Keyboard Drawers shall attach to the underside of rectangular single surface worksurfaces and Basic Corner, Transitional Corner and End of Run Worksurfaces that shall be 42" wide x 24" deep or larger. The Sliding Keyboard Drawer shall have 16" steel ball bearing slides with height adjustments at 3", 3¹/₂" and 4" below the worksurface. They shall be available in the four trim colors. They shall accommodate keyboards up to 9" by 22" on a non-skid surface and shall accept the Optional Wrist Rest.

FlexStation Specifications

Sliding Keyboard Drawer with Mouse Surface

Sliding Keyboard Drawer with Mouse Surface shall attach to the underside of rectangular single surface worksurfaces and Basic Corner, Transitional Corner and End of Run Worksurfaces that shall be 42" wide x 24" deep or larger. They shall have 16" steel ball bearing slides with height adjustments at 3", 3½" and 4" below the worksurface. They shall accommodate keyboards up to 9" by 22" on a non-skid surface and shall accept the Optional Wrist Rest. The mouse surface shall extend to the left or right and provide a 9¼" wide by 9" deep surface. They shall be available in black only.

Fully Adjustable Keyboard Tray

Fully Adjustable Keyboard Trays shall attach to the underside of Basic corner or rectangular worksurfaces and Transitional corner worksurfaces. They shall feature a 5½" vertical adjustment, 359° swivel and a tilt range of 15° positive and 15° negative. The keyboard tray shall slide back to store below the worksurface. The non-skid surface shall accommodate keyboards up to 9" by 22". They shall be available in the four trim colors.

Fully Adjustable Keyboard Tray with Mouse Tray

Fully Adjustable Keyboard Tray with Mouse Tray shall attach to the underside of Basic corner or rectangular worksurfaces and Transitional corner worksurfaces. They shall feature a 5½" vertical adjustment and a tilt range of 15° positive and 15° negative. The keyboard tray shall swivel 359° and retract to store below worksurface. The non-skid surface shall accommodate keyboards up to 9" by 22" and the mouse tray shall extend 9½" to the left or right. They shall be available in black only.

Adjustable Mouse Pad

Adjustable Mouse Pads shall attach to the underside of worksurfaces. They shall have a 5½" vertical adjustment, 359° swivel and slide under the worksurface for storage. They shall have a neoprene surface and shall be available in black only.

CPU Sling

The CPU Sling shall be designed for use with Basic Rectangular Worksurfaces only. It shall attach to the underside of rectangular worksurfaces and accommodate a range of CPU's up to 65" in circumference and a maximum of 75 pounds. It shall provide 5½" of front-to-back travel and 359° swivel for ease of accessibility. The CPU Sling shall be available in black only.

CPU Holder

The CPU Holder shall be designed for use with Manual Height-Adjustable Worksurfaces. It shall attach to the inside or outside of the worksurface leg and shall accommodate a range of CPU's from 4" to 8¼" thick. The holder shall be available in the four trim colors.

Optional Wrist Rest

The Optional Wrist Rest shall fit the Sliding Keyboard Drawer, Sliding Keyboard Drawer with Mouse Surface and Fully Adjustable Keyboard Tray to provide additional wrist support. They shall be available in black.

FlexStation Specifications

OVERHEAD STORAGE

FlexStation shall offer three styles of overhead storage units for use with Basic Rectangular Worksurfaces and corner worksurfaces where full legs are present. They shall be available as a flipper door unit, a flipper door on one half and an open shelf on the other in 60" and 72" widths or as open shelves. Overheads for Basic Rectangular Worksurfaces shall attach through the grommets in the top of the worksurface. They shall have vertical wire channels that conceal the attachment and wires from the top of the shelf to the worksurface.

Overhead cabinets shall be 34" high and shall have 18½" clearance between the worksurface and the bottom of the shelf. The flipper door opening shall be 13" high.

Overhead storage units for height-adjustable worksurfaces shall be used with the specially designed worksurfaces for use with overheads. This worksurface shall have cutouts on each side to allow the top to raise and lower without interfering with the overhead cabinet. Adjustable-Height Overheads shall attach to the outside of the table legs. When the worksurface is at 29" the clearance between overhead and top shall be 18½".

Overhead Cabinet with Flipper Doors

Overhead Cabinets with Flipper Doors shall be a solid core construction for backs and end panels with high-pressure laminate finishes, edges shall be finished with flat vinyl T-molding. Doors shall be available with high-pressure laminate or fabric surface and shall be random keyed or optional keyed-alike shall be available to match other overheads or pedestals. Units measuring 30" to 48" wide shall have a single door, while 54", 60", 66" and 72" units shall have two doors.

Overhead with Door and Shelf Combo

Overhead with Door and Shelf Combo shall be the same construction as the flipper door units, except shall be available with a door on one side and an open shelf on the other. Units shall be available in 60" and 72" widths only. Door position shall be specified left or right.

Open Shelf

Open Shelves shall be the same construction as Flipper Door Cabinets but shall only have open shelves. Units shall be available in the full range of sizes, 30" to 72" wide.

OVERHEAD STORAGE ACCESSORIES

FlexStation offers a full range of accessories for use with overhead storage units. Task lights provide illumination for the worksurface and a paper management system adds organization to the area above the worksurface.

Task Lights

Task Lights shall be offered as an energy efficient electronic ballast task light. The energy efficiency model shall have an electronic ballast with rapid start, cool-white T5 fluorescent lamp.

Task Lights shall attach to the underside of the shelf on overhead cabinets. Lights shall be UL Listed and available in black only. They shall be available 18" wide for use with 24" wide overhead cabinets, 24" wide for use with 30" and 36" wide units, 36" wide for 42" and 48" wide units, and 48" wide for 54" and 60" wide units. Specify (2) 24" wide for use with 66" and 72" Universal or Venus Overheads.

FlexStation Specifications

PAPER MANAGEMENT SYSTEM

The Contemporary Paper Management System shall address the storage and movement of files, binders and documents. Components shall be available with integrated hooks for attachment to the Tool Rail. The system shall be available in the five trim colors.

Tool Rail

Aluminum extrusion tool rail, powder-coated finish. Shall attach between overhead uprights. Shall consist of four slots to accept paper management components. To be used on WZUS,WZUF, WZUL, WUSS, VNOS, VNOL and VNOF models.

Paper Tray

Shall be constructed of injection molded plastic. Tray measures 9-1/2" wide by 2" high by 14" deep and shall accommodate both letter and legal size documents. Includes three hooks to mount on tool rail.

Vertical Storage

Shall be constructed of injection molded plastic. Holder measures 5" wide by 9" high and 10-1/2" deep. Includes two hooks to mount on tool rail.

Pencil Cup

Shall be constructed of injection molded plastic. Cup measures 4" wide by 3" high by 3-1/2" deep for storage of pens, pencils and highlighters. Includes one hook to mount on tool rail.

Diagonal Storage

Shall be constructed of injection molded plastic. Storage tray shall consist of three diagonal slats with black dividers to sort files or papers. Tray measures 7" wide by 2-1/2" high by 12-1/2" deep and includes three hooks to mount on tool rail.

Telephone Caddy

Shall be constructed of injection molded plastic. Caddy measures 8-1/2" wide by 2" high by 9-1/2" deep. Includes adjustable rail to accommodate a phone up to 10-3/4" deep. Includes three hooks to mount on tool rail.

Accessory Tray

Shall be constructed of injection molded plastic. Holder measures 9-1/2" wide by 2" high by 10" deep and includes three hooks to mount to tool rail. Tray includes six compartments for storage of supplies.

FlexStation Specifications

PRIVACY SCREENS

Privacy screens shall provide sit-down privacy within the FlexStation workstation. Screens shall be 19" high and available in widths to fit all basic and transitional worksurfaces — straight, corner, with or without keyboard pad.

Screens shall be fabric covered and useable as a tackable surface. The fabric surface on both sides shall allow one set of screens to serve two worksurfaces placed back-to-back. Privacy Screens shall be useable on worksurfaces with overhead storage units to close the opening between the worksurface and the bottom of the shelf. Screens shall include mounting brackets and alignment plates to provide secure mounting. Corner screens shall include a corner alignment plate. Screens shall be available in configurations to match the worksurface application — basic worksurface, corner worksurface or transitional worksurface.

Mounting brackets are available in the WZP and WZAP styles. The WZP bracket is constructed of formed steel while the WZAP bracket is constructed of extruded aluminum and attached to a steel plate. The WZAP bracket should be used when more rigidity is required.

Basic Worksurface Privacy Screens

Basic worksurface privacy screens shall be designed for straight line applications. They shall include mounting brackets for attachment to the worksurface and a full-height, steel splice plate to align adjoining screens. Screens shall be available for straight applications in 24", 30", 36", 42", 48", 54", 60", 66" and 72" widths. The 60", 66" and 72" widths shall consist of a pair of screens.

Overhead Privacy Screens

Same construction as basic privacy screen except that it mounts flush to the back of the overhead and is attached to the underside of the worksurface. The screens attach to the worksurfaces with fasteners.

Corner Worksurface Privacy Screens

Corner Worksurface Privacy Screens shall be available as a pair of screens to enclose the corner. They shall have a 90° splice plate to align the screens. Corner screens shall be available for 36", 42" and 48" corner worksurfaces.

Transitional Worksurface Privacy Screens

Transitional Worksurface Privacy Screens shall be offered in sizes and combinations of screens to enclose the corner occupied by a particular transitional worksurface, corner, square, rectangle and triangle. The End of Run Transitional Worksurface shall use a corner screen if both sides are to be screened.

FlexStation Specifications

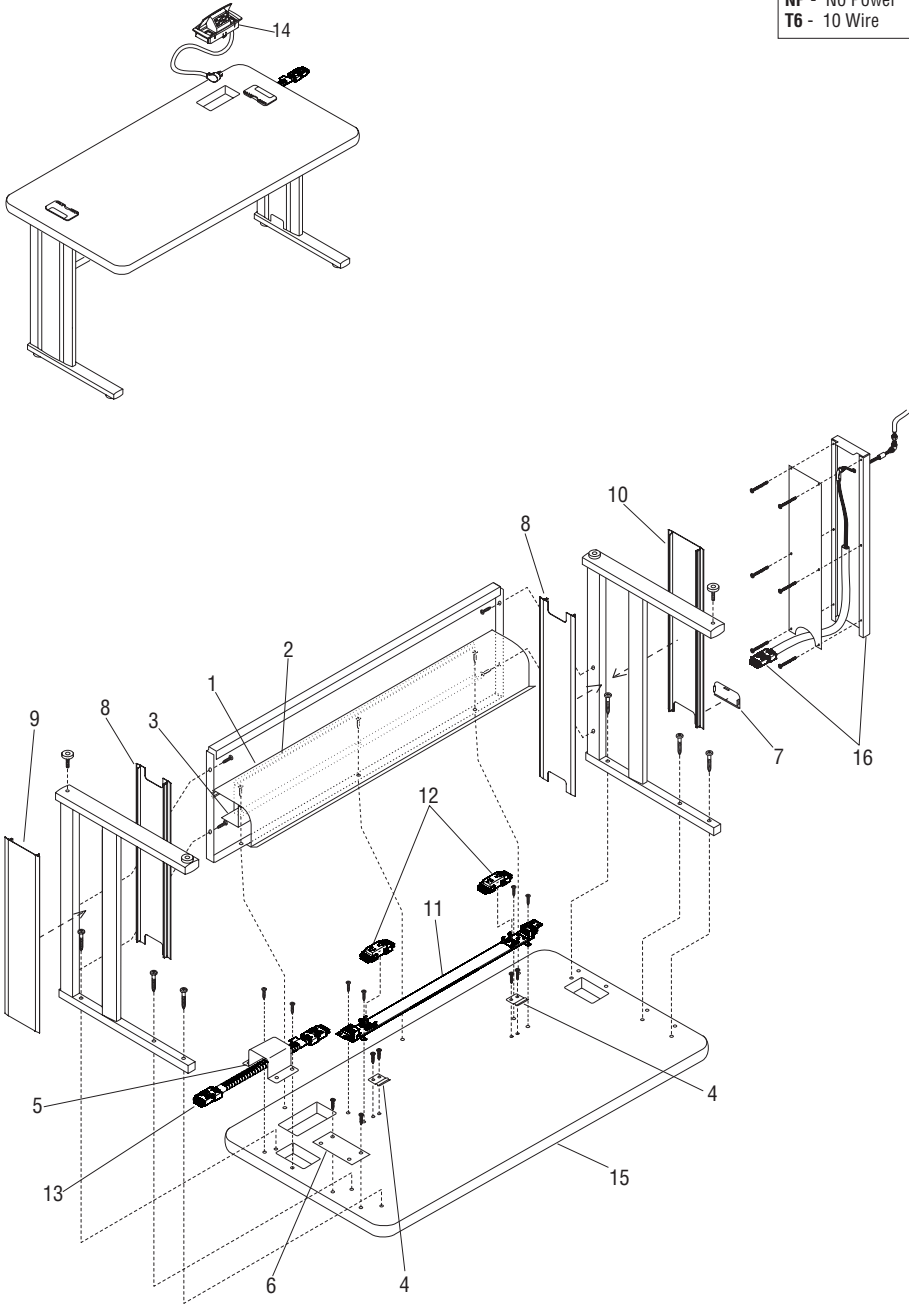

PowerUp Parts Listing

Legend		Item No.	Item Description	NT	WT	NP	T6
NT	- No Trough						
WT	- With Trough						
NP	- No Power						
T6	- 10 Wire						
		1	Data Door 30"		•		
			Data Door 36"		•		
			Data Door 42"		•		
			Data Door 48"		•		
			Data Door 54"		•		
			Data Door 60"		•		
			Data Door 66"		•		
			Data Door 72"		•		
		2	Door Mounting Bracket 30"		•		
			Door Mounting Bracket 36"		•		
			Door Mounting Bracket 42"		•		
			Door Mounting Bracket 48"		•		
			Door Mounting Bracket 54"		•		
			Door Mounting Bracket 60"		•		
			Door Mounting Bracket 66"		•		
			Door Mounting Bracket 72"		•		
		3	Steel Power/Data Divider 30"		•		
			Steel Power/Data Divider 36"		•		
			Steel Power/Data Divider 42"		•		
			Steel Power/Data Divider 48"		•		
			Steel Power/Data Divider 54"		•		
			Steel Power/Data Divider 60"		•		
			Steel Power/Data Divider 66"		•		
			Steel Power/Data Divider 72"		•		
		4	Clips for Door		•		
		5	Table-To-Table Wireway		•		•
		6	Splice Plate	•	•	•	•
		7	Cap fo Vertical Wireway		•		•
		8	Vertical Wireway - Inner	•	•	•	•
		9	Vertical Wireway - Outer, End-Of-Run	•			
		10	Vertical Wireway - Outer		•		•
		11	10-Wire Harness 30"				•
			10-Wire Harness 36"				•
			10-Wire Harness 42"				•
			10-Wire Harness 48"				•
			10-Wire Harness 54"				•
			10-Wire Harness 60"				•
			10-Wire Harness 66"				•
			10-Wire Harness 72"				•
		12	Duplex Receptacles (optional - must be ordered separately)				
		13	10-Wire Table-To-Table Connector (optional - must be ordered separately)				
		14	Power Data Module				
		15	WorkZone Top only with cut-outs				
		16	Steel Infeed 27" Cover Plate Assembly				
			Steel Infeed 29" Cover Plate Assembly				
			Steel Infeed 42" Cover Plate Assembly (optional - must be ordered separately)				

