

Assembly Instructions ■

FlexStation Privacy Screen
30", 36", 48", 60", 66" and 72" Units

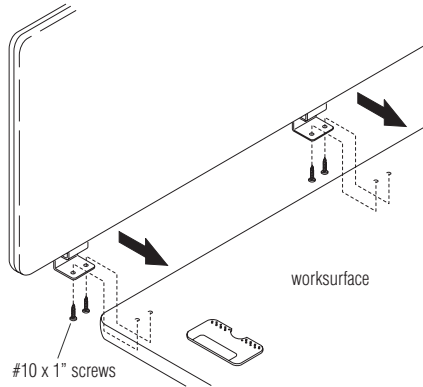

Figure 1

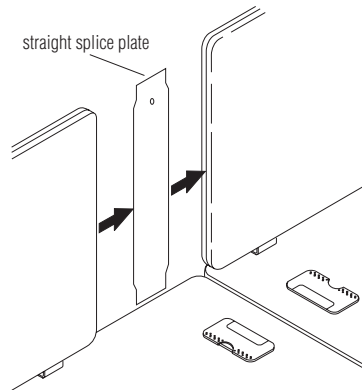

Figure 2

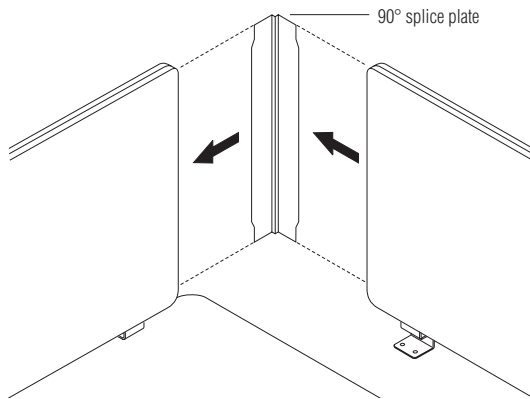

Figure 3

Note: Start at one end of a run and work your way around to the other end.

1. Position privacy screen with bracket on the top back edge of the worksurface. Line up the left and right edges of the privacy screen with the left and right edges of the worksurface (Figure 1).
2. Attach to pre-drilled holes in worksurface with #10 x 1" screws (four screws on 30" and 36" privacy screens (Figure 1).

Transitions

Privacy screens and splice assembly procedures are the same as in a straight run (Figure 3).

- a. Keyboard Transitional Surface (90° splice plate)
- b. Rectangular Transitional Surface (90° splice plate)
- c. Square Transitional Surface (90° splice plate)
- d. Triangular Transitional Surface (45° splice plate)

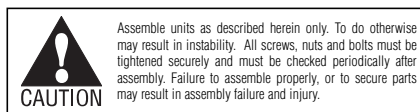

Assemble units as described herein only. To do otherwise may result in instability. All screws, nuts and bolts must be tightened securely and must be checked periodically after assembly. Failure to assemble properly, or to secure parts may result in assembly failure and injury.