

# Planning Guide ■

Legion® Panel System

July 2018



## ■ Legion® Panel System – Introduction

Planning Guide



A. Vini Wardrobe/Bookcase  
B. Glass Divider

C. Monolithic Panel  
D. Tile-To-Floor

E. Vini Wardrobe/Bookcase  
F. Vini Underhead

G. Tapered Worksurface  
H. Support Leg  
I. Vini Credenza

Legion is the unifying element that brings together architecture and furniture to create highly effective work environments that are both engaging and productive. As a comprehensive Systems offering, Legion features pre-configured panels, worksurfaces, storage elements and accessories, which together allow for dynamic planning solutions. Yet, Legion also brings a degree of simplicity to Systems furniture that other systems lack. Uncomplicated, but by no means boring, Legion simplifies the entire Systems furniture process—from planning and specifying, to ordering and installing—so more time is spent appreciating the end result and less time is spent worrying about the details.



J. Supporting Leg With Insert  
K. Standard Base  
L. Vini Overhead

M. Vini Pedestal  
N. Segmented Marker Board  
O. Segmented Glass Panel

P. Series XXI Bookcase  
Q. Suavé Lounge Chair

R. Suavé Lounge Table

■ **Legion® Panel System – Table of Contents**  
Planning Guide

Introduction.....	2
Panels – Product Overview .....	5
Intersection & Trim – Product Overview.....	11
Panel Support & Loading – Planning Guidelines.....	15
Electrical – Product Overview .....	29
Electrical – Planning Guidelines .....	31
Data Terminology – Planning Guidelines .....	52
Electrical Terminology – Planning Guidelines.....	53
Worksurfaces – Planning Guidelines .....	59
Worksurface Supports – Planning Guidelines.....	65
Storage – Product Overview.....	79
Storage – Planning Guidelines.....	82
Accessories – Product Overview .....	90
Accessories – Planning Guidelines.....	91



## LEGION PANELS

Preconfigured Legion panels are offered in monolithic and segmented models. All panels feature a unitized design for easy, quiet installation using a single bolt style for all panel connections. Panels ship complete with welded panel frame, demountable tiles, base components, top caps, adjustable glides, and in-line panel-to-panel connection hardware. Panels are non-progressive, and all may be used for either intersection or in-line conditions. Panels include standard top caps, but may also be specified with optional spanning top caps or divider screens.

Preconfigured panels are 3.5" thick and are available in the following dimensions:

- Widths: 24", 30", 36", 42", 48", 54", 60", 72" (split tile on 72")
- Heights: 32", 40", 48", 56", 64"; 16" stacking sections
- 

Three base styles allow for functional and aesthetic planning flexibility:

- Standard base
- Elevated base
- Tile-to-floor base

Insert tiles are interchangeable among standard, elevated, and the base side of tile-to-floor panels. The tile height of the tile-to-floor tile is unique and not interchangeable. All tiles are hand-placed, requiring no tools for attachment to Legion frames. Standard and elevated base styles support reconfiguration that substitutes either base style for the other.

Standard bases allow for distribution of power and data at the base of the panel. Elevated bases improve air circulation and lighten overall scale of the panel. Tile-to-floor panels feature a base raceway on the user side only and tile-to-floor without power cut-outs on the opposite side. Above worksurface beltway power is available regardless of base style.

Receptacles for all Legion panels must be ordered separately. Bezel plates are pre-assembled into powered tiles. Base raceways contain steel knock outs. Base raceway bezel plates are shipped with receptacles.

**Preconfigured Monolithic Panels**

Preconfigured monolithic panels are offered with fabric tile inserts. Fabric tiles feature a variety of vertical fabrics adhered to acoustical fiberglass boards. Fabric wraps around the board on all sides to minimize end fraying.

Widths: 24", 30", 36", 42", 48", 54", 60" & 72" (split tile on 72")

Heights: 32", 40", 48", 56" & 64"

**Fabric**

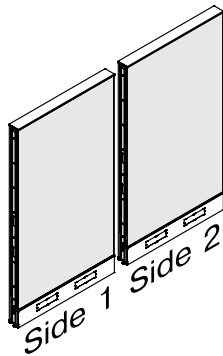

Standard Base (2 sides)  
 Base Power (2 sides)

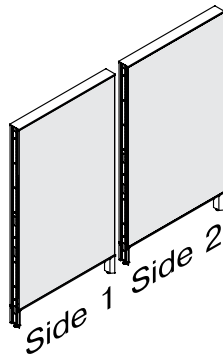

Elevated Base (2 sides)  
 No Power

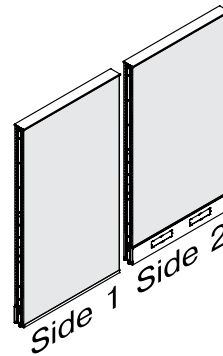

Tile-to-Floor & Standard Base  
 Base Power (1 side)

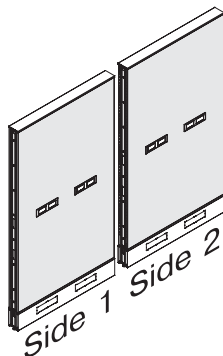

Standard Base (2 sides)  
 Base & Beltway Power

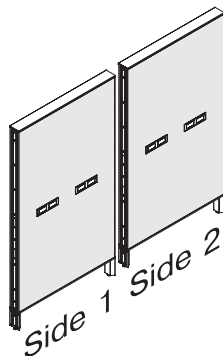

Elevated Base (2 sides)  
 Beltway Power (2 sides)

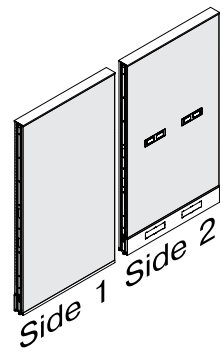

Tile-to-Floor & Standard Base  
 Base & Beltway Power (1 side)

**Bottom Open**

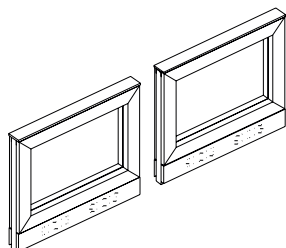

Standard Base (2 sides)  
 Base Power (2 sides)

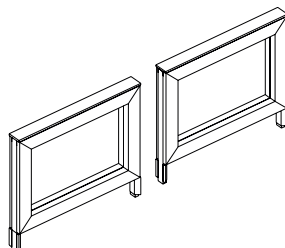

Elevated Base (2 sides)  
 No Power

**Preconfigured Segmented Panels**

Preconfigured segmented panels are available in a variety of substrate and finish choices. Segmented panels universally feature a 32" from floor segmentation height, with specified upper and lower, and front and back tiles. Preconfigured substrates vary by configuration and may include:

- Fabric - Upper and Lower
- Single Pane Glass - Upper
- Steel Laminated Markerboard - Upper

Widths: 24", 30", 36", 42", 48", 54", 60" & 72" (split tile on 72")  
 Heights: 40", 48", 56" & 64"

**Fabric/Fabric**

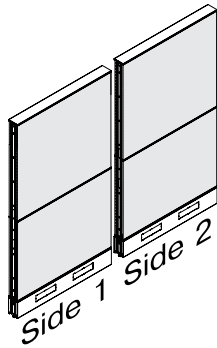

Standard Base (2 sides)  
 Base Power (2 sides)

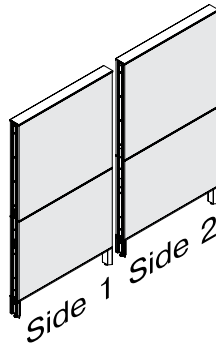

Elevated Base (2 sides)  
 No Power

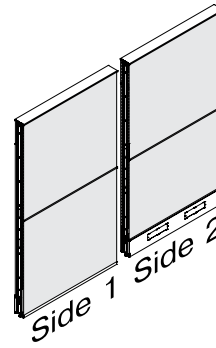

Tile-to-Floor & Standard Base  
 Base Power (1 side)

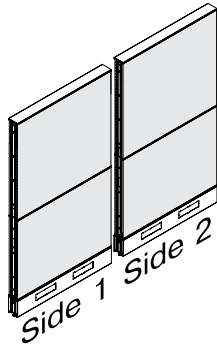

Standard Base (2 sides)  
 Base & Beltway Power (2 sides)

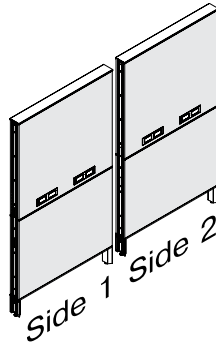

Elevated Base (2 sides)  
 Beltway Power (2 sides)

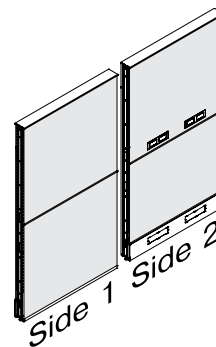

Tile-to-Floor & Standard Base  
 Base & Beltway Power (1 side)

**Preconfigured  
Segmented Panels**

**Fabric/Glass**

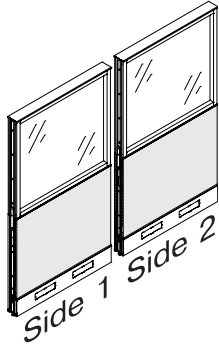

Standard Base (2 sides)  
Base Power (2 sides)

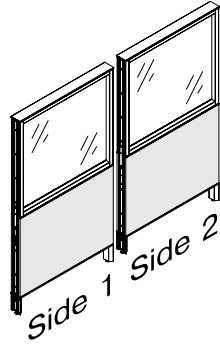

Elevated Base (2 sides)  
No Power

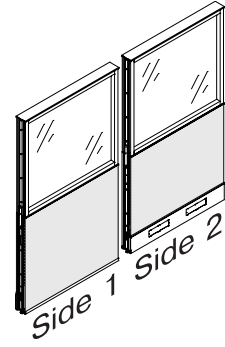

Tile-to-Floor & Standard Base  
Base Power (1 side)

**Fabric/Open**

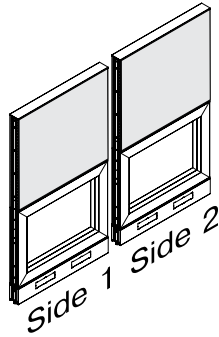

Standard Base (2 sides)  
Base Power (2 sides)

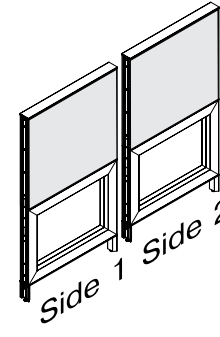

Elevated Base (2 sides)  
No Power

**Preconfigured  
 Segmented Panels**

**Fabric Lower/Markerboard Upper**

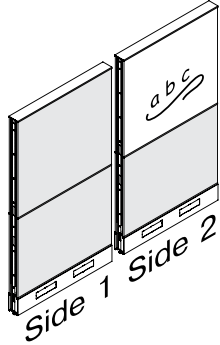

Standard Base (2 sides)  
 Base Power (2 sides)

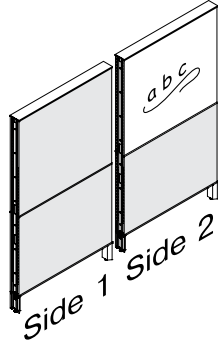

Elevated Base (2 sides)  
 No Power

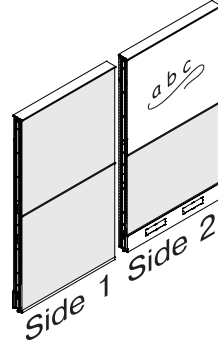

Tile-to-Floor & Standard Base  
 Base Power (1 side)

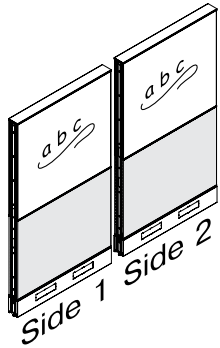

Standard Base (2 sides)  
 Base Power (2 sides)

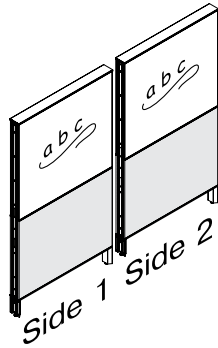

Elevated Base (2 sides)  
 No Power

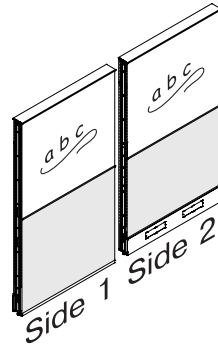

Tile-to-Floor & Standard Base  
 Base Power (1 side)

**Fabric Lower/Perforated Steel Upper**

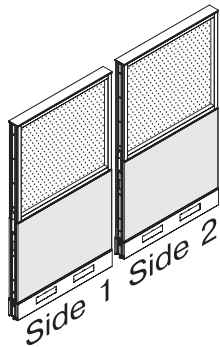

Standard Base (2 sides)  
 Base Power (2 sides)

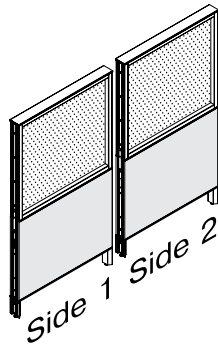

Elevated Base (2 sides)  
 No Power

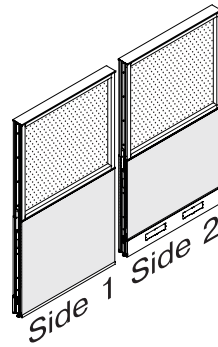

Tile-to-Floor & Standard Base  
 Base Power (1 side)

**Preconfigured  
Stacking Panels**

Preconfigured Stacking Panels add 16" to any Legion panel, and may be retrofitted to most existing installations. All parts and hardware are included. Only one stacking section may be used. Stacking Panels can be placed along any main run, or on top of a return. Planning rules include stacking sections when panel height change rules apply. Stacking Panels cannot be placed above segmented glass panels, or segmented perforated steel panels. Stacking Panels **CANNOT** be load bearing. Preconfigured models are available with inserts of the following tiles:

- Fabric
- Powder-Coated Solid Steel
- Powder-Coated Perforated Steel
- Single Pane Glass
- Steel Laminated Markerboard

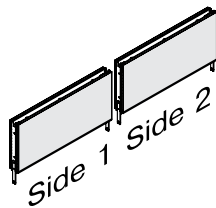

Fabric (2 sides)

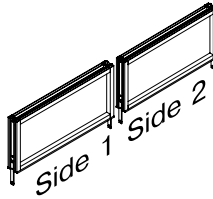

Steel (2 sides)

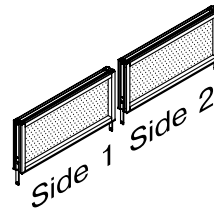

Perforated Steel (2 sides)

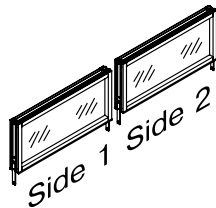

Glass (2 sides)

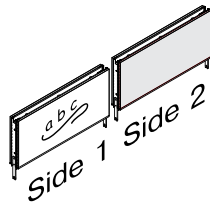

Markerboard & Fabric

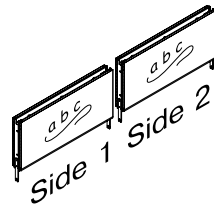

Markerboard (2 sides)

**90° Intersection Conditions**

Legion panels include necessary panel connector blocks and light blocks at 90° and 120° intersections. Connectors are universal and allow panel-to-panel connections of same or varied heights, as well as all panel-to-post and top cap connections. Trim included with panels consists of top cap, segmented trim, bottom trim channel or tile-to floor trim, base raceway cover and foot shroud. End of run trim and spanning top cap, are specified separately. All Legion trim is powder-coated metal.

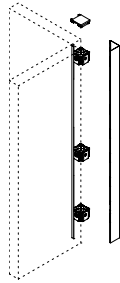

2-Way 90°, "L" Corner  
 No Height Change

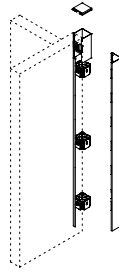

2-Way 90°, "L" Corner  
 With Height Change

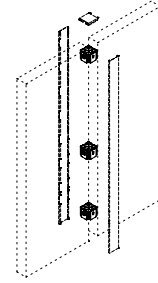

2-Way 180°, In-Line  
 No Height Change

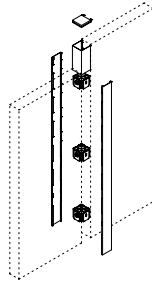

2-Way 180°, In-Line  
 Trim One side  
 With Height Change

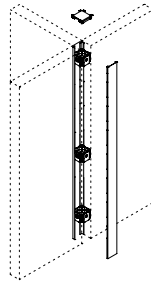

3-Way 90°, "T" Corner  
 No Height Change

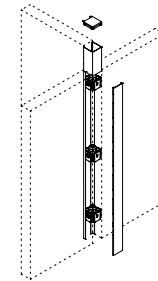

3-Way 90°, "T" Corner  
 Trim One Side  
 With Height Change

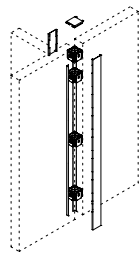

3-Way 90°, In-Line "T" Corner  
 Trim Two Sides  
 With Height Change

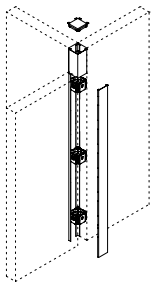

3-Way 90°, "T" Corner  
 Trim Two Sides  
 With Height Change

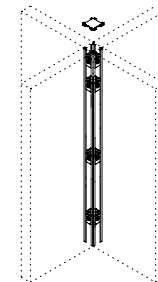

4-Way 90°, "X"  
 No Height Change

■ Legion® Panel System – Product Overview - Intersection & Trim  
 Planning Guide

**90° Intersection Conditions**

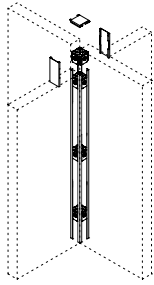

4-Way 90°, "X" In-Line  
 With Height Change

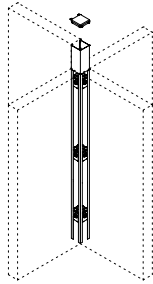

4-Way 90°, "X"  
 Trim Three Sides  
 With Height Change

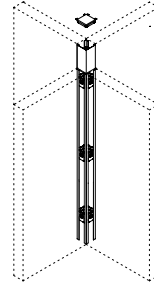

4-Way 90°, "X"  
 Trim Two Sides  
 No Height Change

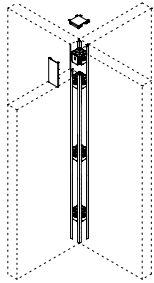

4-Way 90°, "X"  
 Trim One Side  
 With Height Change

**90° Stackable Intersection Conditions**

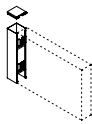

1 Way 90° End

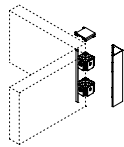

2-Way 90° Corner

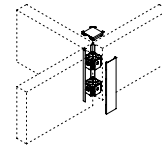

3-Way 90° Intersection

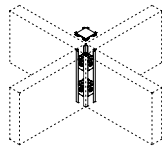

4 Way 90° Intersection

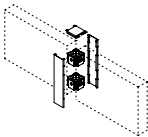

2-Way 180° In-Line Spacer



**120° Intersection  
 Conditions**

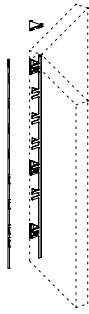

2-Way 120° Corner  
 No Height Change

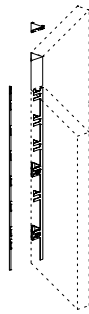

2-Way 120° Corner  
 With Height Change

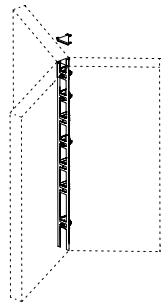

3-Way 120° Corner  
 No Height Change

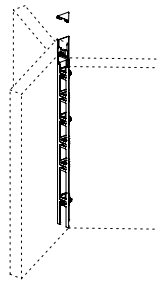

3-Way 120° Corner  
 Trim One Side  
 With Height Change

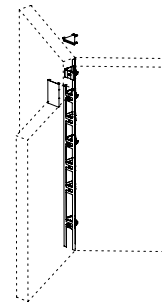

3-Way 120° Corner  
 Trim Two Sides  
 With Height Change

**120° Stackable  
 Intersection  
 Conditions**

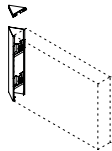

1 Way 120° End

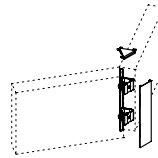

2-Way 120° Corner

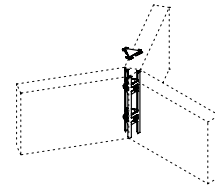

3-Way 120° Intersection

# ■ Legion® Panel System – Product Overview - Intersection & Trim

Planning Guide

## End-of-Run Trim

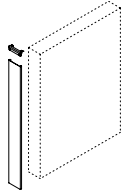

End-of-Run Trim  
For Full Height

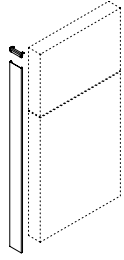

End-of-Run Trim  
For Seamless Full Height  
With Stacking Section

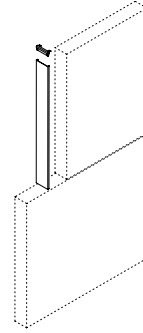

Variable Trim  
For Change-of-Height  
Conditions

## End-of-Run Trim Stacking

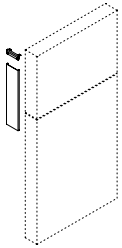

End-of-Run Trim  
Additive Stacking Section  
Straight Vertical

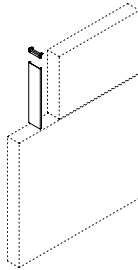

End-of-Run Trim  
Stacking Section at  
Variable Height Condition

**UNLOADED PANELS**

The figures show the maximum and minimum requirements for safe loading and supporting of panels. Follow them carefully to ensure panel stability.

**Wall-Mounted Panel Run with No Loading**

**Wall-Mounted Panels with No Return**

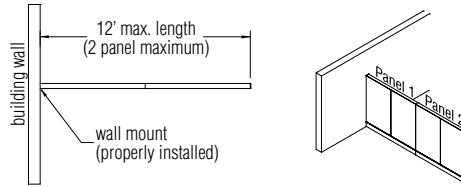

- Maximum run: 2 panels, 12' maximum length.

**Note:** Two 72" panels are shown. 72" panels have 2 tiles per side of a single panel frame.

**Note:** 2 panels, 8' maximum length for runs that contain **Glass or Stacking Panel (all insert type) Sections.**

**Wall-Mounted Panels with Return on One Side**

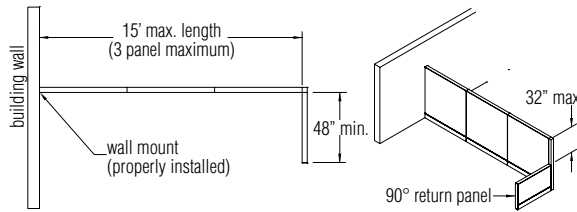

- Maximum run: 3 panels, 15' maximum length.
- Minimum return panel width: 48".
- 90° intersection return panels must be within 32" of main run height.
- 120° intersection return panels must be within 24" of main run height.

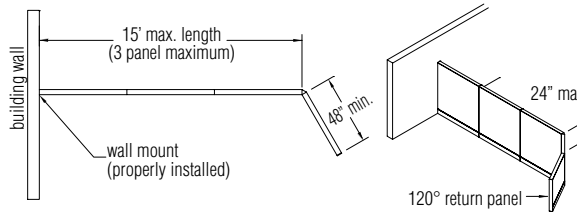

**Wall-Mounted Panels with Returns on Both Sides**

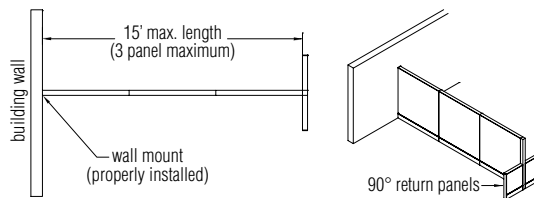

- Maximum run: 3 panels, 15' maximum length.
- Minimum return panel width: 48".
- For 90° and 120° intersections, return panels may be any height.

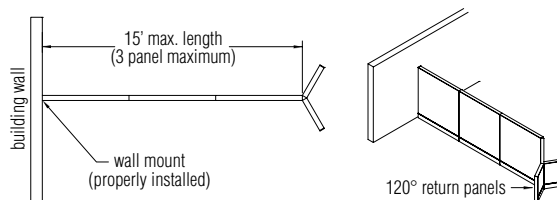

**Unloaded  
 Freestanding Panel  
 Runs with Panel  
 Returns at Both Ends**

**Panels Without Loading & with Returns on One Side**

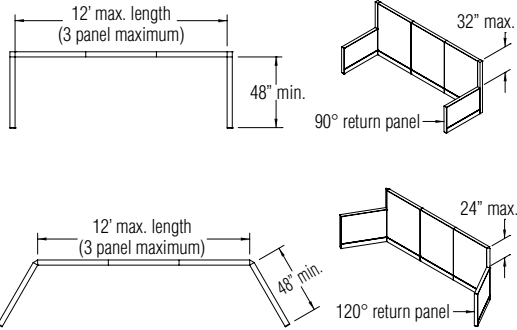

- Maximum run: 3 panels, 12' maximum length.
- Minimum return panel width: 48"
- 90° intersection return panels must be within 32" of main run height.
- 120° intersection return panels must be within 24" of main run.

**Panels Without Loading & with Returns on Both Sides**

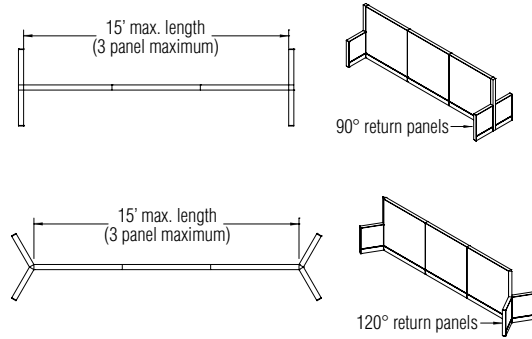

- Maximum run: 3 panels, 15' maximum length.
- Minimum return panel width: 24"
- 90° and 120° intersection return panels may be any length.

**120° Panels Without Loading & with Alternating Returns**

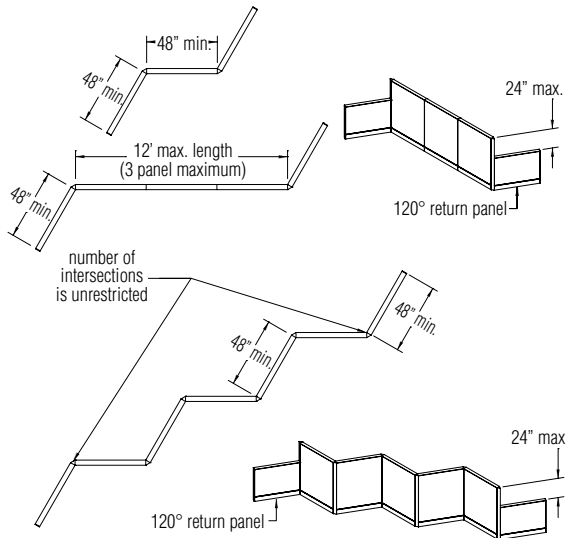

- Maximum run: 3 panels, 12' maximum run between intersections.
- Minimum return panel width: 48"
- The end panels in a run function as returns. They must be of a minimum width of 48", and within 24" of the height of the main run of panels.
- The total number of intersection panels is unrestricted, provided that all panels between intersections follow the rules noted above.

**Unloaded Panels as Unsupported Panel Returns**

**Panels Mounted with No Returns**

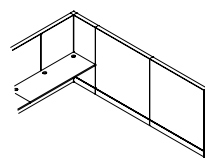
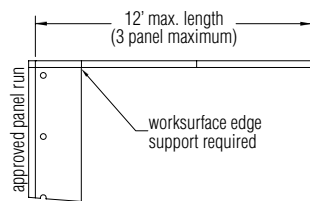
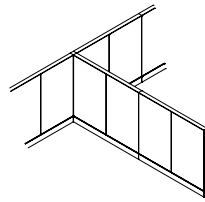
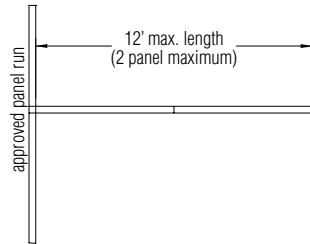

- Maximum run: 2 panels, 12' maximum unsupported return length.
- **Note:** Two 72" panels are shown. 72" panels have 2 tiles per side of 1 panel frame.
- If worksurface support bracket is used:  
Maximum run: 3 panels, 12' maximum return length.

**LOADED AND UNLOADED PANEL RETURN STYLES**

**Weight Capacities**

Legion hang-on components (excluding marker boards, tack boards, and tool rails) include a special designed hanging bracket that includes a feature to prevent accidental dislodgement from the panel or wall track.

All Legion components meet or exceed the BIFMA (Business and Institutional Furniture Manufacturers Association) standards for hang-on components.

BIFMA has two load tests for hang-on components:

1. Functional Load - at this load the test furniture must still be useable with no deformation or breakage.
2. Proof Load - at this load the test furniture must still be safely useable, but deformation is allowed.

The following are the BIFMA X5.6-2010 test loads for two categories of hang-on components, worksurfaces and overhead storage units.

Worksurfaces

Concentrated - When testing units with lengths (or dia.) greater than 1829 mm (72"), two concentrated loads are required. Loads are applied through a 12" diameter disk.

Functional Load: 200 lbs.

Proof Load: 300 lbs.

Distributed - (inside perimeter measured 8" from edge).

Functional Load: 1.5 lbs/linear inch for 60 minutes.

Proof Load: 2.3 lbs/linear inch for 15 minutes.

Overhead Storage Units

Functional Load: 3.0 lbs/linear inch for 60 minutes.

Proof Load: 3.0 lbs/linear inch for 15 minutes.

**Note:** The lofting force required to open an overhead door (based upon a 48" Legion) is 6.0 lbs.

Underhead Storage Units

Functional Load: 3.0 lbs/linear inch for 60 minutes.

Proof Load: 3.0 lbs/linear inch for 15 minutes.

The following return styles are considered equivalent and are allowed for all approved main panel run length and height combinations.

- 90° or 120° of 2 approved main runs with either intersecting spliced together worksurfaces or corner worksurface shapes are allowed to function as returns for all loading conditions.
- In-Line Variable height worksurfaces are allowed in all situations.
- For corner variable height layouts, the lower worksurface must use a perpendicular worksurface return style appropriate to the main panel loading.

**Note:** For storage-only loading, "panel return" and "underhead with support leg" are the only allowed return styles.

**Supports for Panels with Worksurface/Overhead Storage Loading**

**Panel Return**

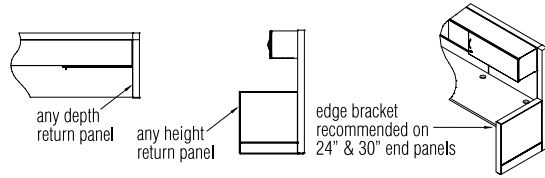

- Any dimension panel can be used as a panel return.
- For maximum run lengths, refer to the Unloaded Panels section, pages 17 & 18.
- Edge Support Brackets are recommended if worksurface depth matches the return panel (24" and 30" deep worksurfaces).

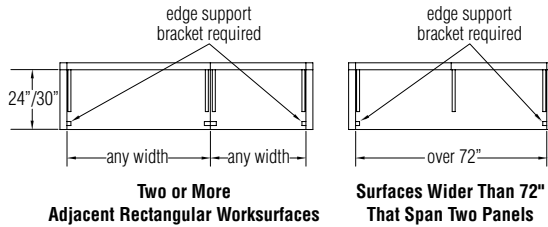

- Edge Support Brackets are required only with adjacent worksurfaces and worksurfaces wider than 72" that span panels. Return Panel must match depth of worksurface (24" and 30" deep worksurfaces).

**Support Leg, Panel Mounted**

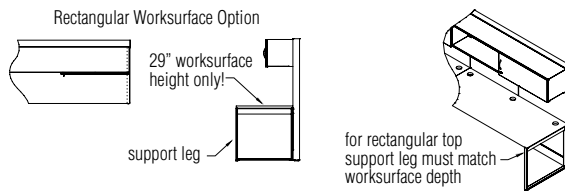

- Width of support leg must match depth of worksurface.
- Peninsula worksurfaces must use either an 18" minimum worksurface/panel support leg in combination with a peninsula post leg (option 1) or a full length panel support leg (option 2).

**Peninsula Worksurface Option 1**

**Peninsula Worksurface Option 2**

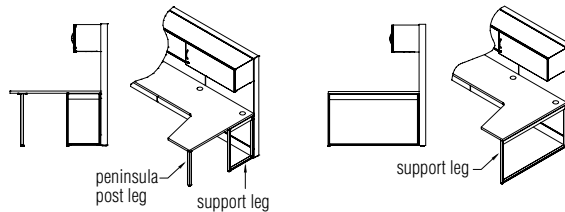

**Perpendicular Worksurface with Support Leg, Panel Mounted**

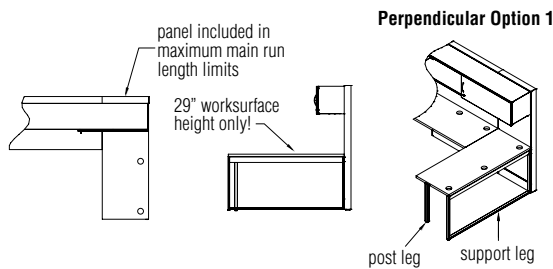

- Worksurface must be mounted to panel of equal length to edge along main run. This panel is included in main run number of panels/maximum length rules.
- Worksurface must use either a full length support leg in combination with a post leg or an 18" (minimum) support leg in combination with one of the end support options listed.
- End support may be options 2, 3 or 4 shown at left.

**Perpendicular Option 2**

**Perpendicular Option 3**

**Perpendicular Option 4**

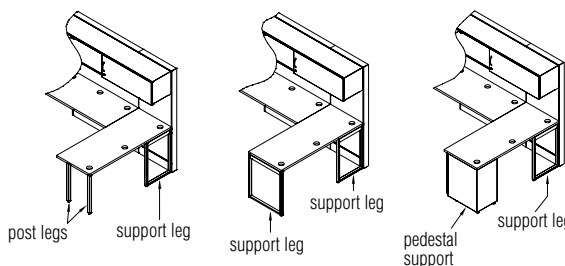

**Supports for Panels with Worksurface/Overhead Storage Loading (cont.)**

**Vini Pedestal Files with Brackets**

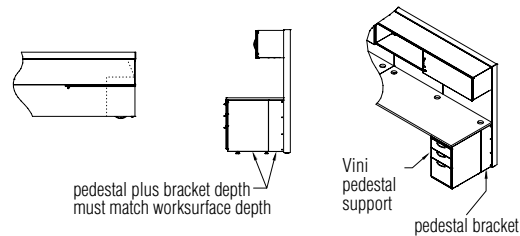

- Accessory pedestal bracket must be specified to match depth of worksurface.
- Accessory bracket may be used with double pedestals.

**Supports for Panels with Worksurface-Only Loading**

**Peninsula Worksurface with Support Leg, Panel Mounted**

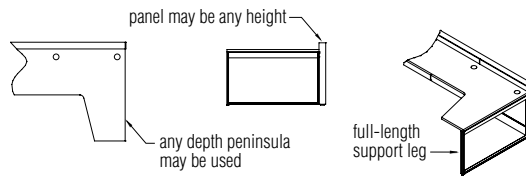

- Peninsula worksurfaces may use a full-length support leg without peninsula post leg.

**Peninsula Worksurface Mounting with Design Bracket and Post Leg**

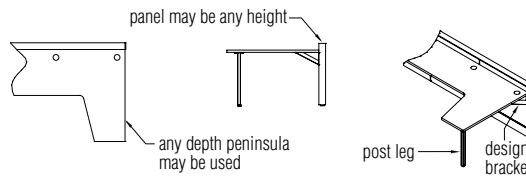

- Peninsula worksurfaces must specify a cantilever bracket or design bracket in conjunction with a single post leg.
- Panels may only have worksurface loading.

**Unloaded Panels as Unsupported Panel Returns**

**Perpendicular Worksurface with Design Bracket & End Support**

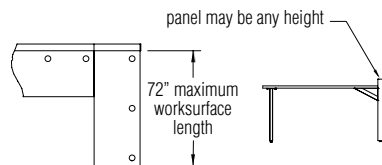

- Perpendicular worksurface must be mounted to a panel of equal width along main run. This panel is included in main run number of panels and maximum length rules.
- If worksurface is adjacent to another worksurface, panel support is achieved with one design bracket AND one edge support bracket.
- If worksurface is mounted on its own, panel support requires one bracket on outside and any Legion cantilever bracket style on the inside.
- End support may be options 1, 2 or 3 shown at left.

**End Support Option 1**

**End Support Option 2**

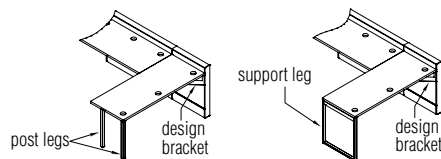

**End Support Option 3**

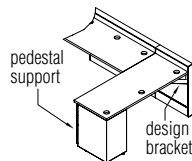

**Wall-Mounted Panel Run with Worksurface Loading**

**Wall-Mounted Panels with Loading/Returns on One Side**

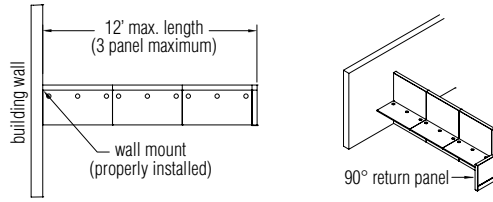

- Maximum run: 3 panels, 12' maximum run length.

**Freestanding Panel Runs with Worksurface Loading**

**Panels with Returns on One Side**

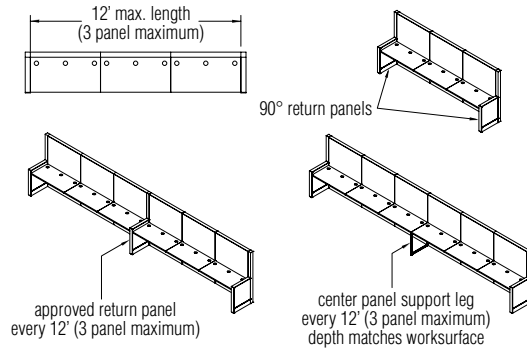

- Maximum run: 3 panels, 12' maximum run length.
- Worksurfaces can be any depth; however, they must be connected to adjacent worksurfaces by the appropriate splice plate.
- Main run may be of any length provided an approved return occurs every 12' along main run panel.
- A center panel support leg may function as a return in this configuration.
- For maximum rigidity, 24" and 30" deep worksurfaces must use worksurface edge supports with return panels of equal length. See rules for panel returns and use of edge support brackets (page 16).

**120° Panels with Returns on One Side**

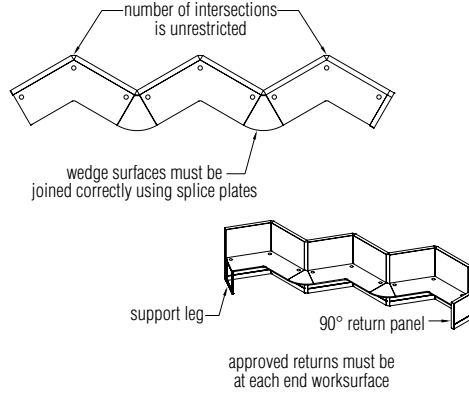

- In 120° panel runs, the maximum panel length and number of panels are unrestricted.
- Worksurfaces may be any depth, but must be planned so they are continuous down each side, and are spliced together.
- Panels must be a minimum of 36" width.
- Approved returns must be used at each end of the run on the last worksurface.

**Wall-Mounted Panel Run with Worksurface Loading**

**Wall-Mounted Panels with Loading/Returns on Both Sides**

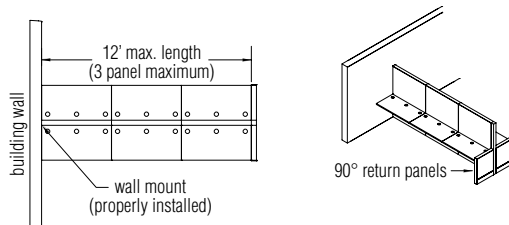

- Maximum run: 3 panels, 12' maximum run length.



**Freestanding Panel Runs with Worksurface Loading**

**Panels with Balanced Worksurface Loading & Returns on Both Sides**

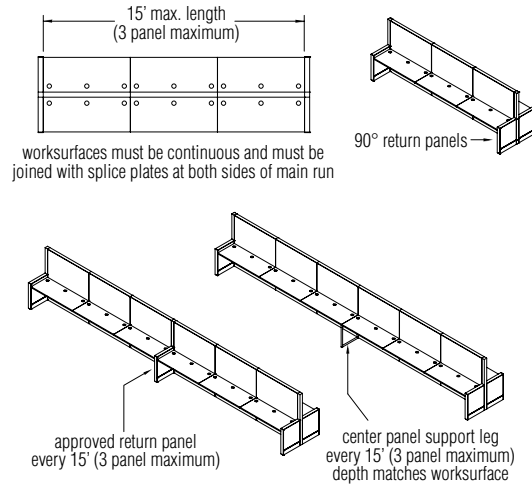

- Maximum run: 3 panels, 15' maximum run length.
- Worksurfaces can be any depth; however, they must be connected to adjacent worksurfaces by the appropriate splice plate.
- Main run may be of any length provided an approved return occurs every 12' along main run panel.
- A center panel support leg may function as a return in this configuration.
- For maximum rigidity, 24" and 30" deep worksurfaces must use worksurface edge supports with return panels of equal length. See rules for panel returns and use of edge support brackets (page 16).

**120° Panels with Balanced Worksurface Loading & Returns on Both Sides**

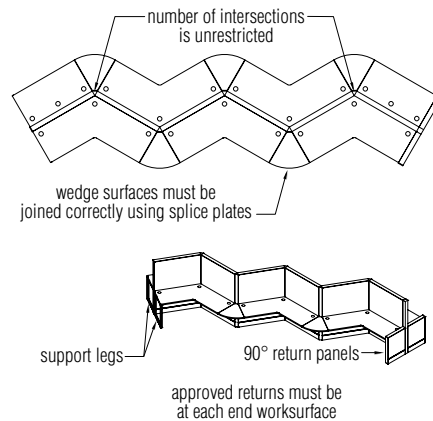

- In 120° balanced layouts the maximum panel length and number of panels are unrestricted.
- Worksurfaces may be any depth, but must be planned so they are continuous down each side, and are spliced together. Panels must be a minimum of 36" wide.
- Approved returns must be used at each end of the run on the last worksurface.

**Wall-Mounted Panel Runs with Overhead Storage Loading**

**Wall-Mounted Panels with Storage Loading & Returns on One Side**

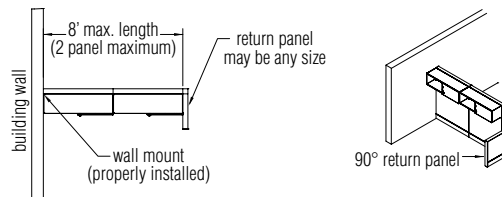

- Maximum run: 2 panels, 8' maximum run length.

**Freestanding Panel Runs with Overhead Storage Loading**

**Panels with Storage Loading & Returns on One Side**

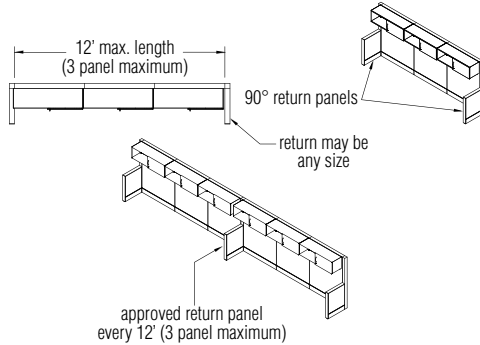

- Maximum run: 3 panels, 12' maximum run length.
- Main run may be of any length provided an approved return occurs every 12' along main panel run.

**120° Panels with Storage Loading & Returns on One Side**

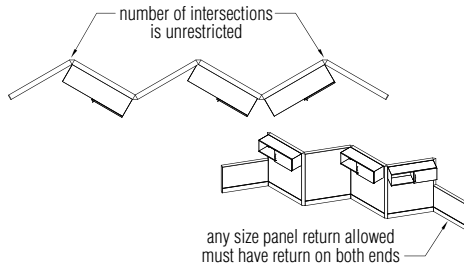

- Maximum panel length and number of panels are unrestricted.
- Panels must be a minimum of 36" width. Panel return must be used at each end but any size panel may be used.

**Wall-Mounted Panel Runs with Overhead Storage Loading**

**Wall-Mounted Panels with Balanced Storage Loading & Returns on Both Sides**

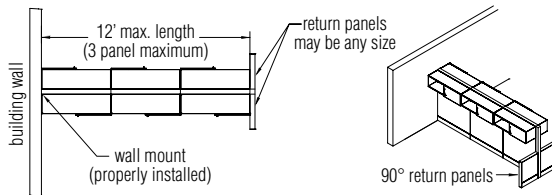

- Maximum run: 3 panels, 12' maximum run length.

**Freestanding Panel Runs with Overhead Storage Loading**

**Panels with Balanced Storage Loading & Returns on Both Sides**

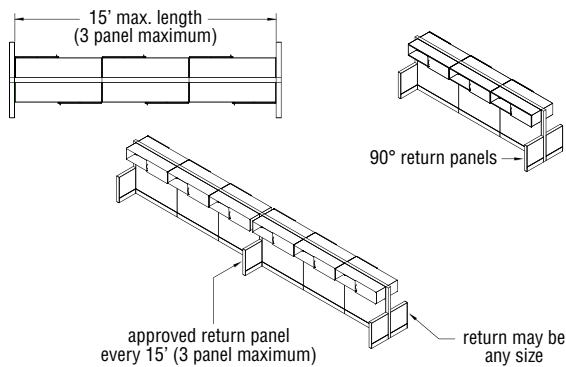

- Maximum run: 3 panels, 15' maximum run length.
- Main panel run may be of any length provided an approved return occurs every 15' along main panel run on both sides.
- Only panel return styles can be used for this layout.

**Freestanding Panel Runs with Overhead Storage Loading (cont.)**

**120° Panels with Balanced Storage Loading & Returns on Both Sides**

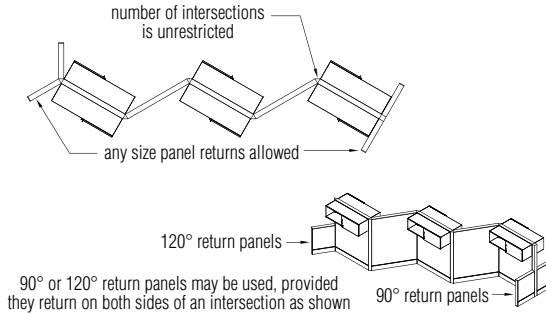

- Maximum panel length and number of panels are unrestricted.
- Panels must be a minimum of 36" width.
- Approved returns must be used at each end of the run.

**Wall-Mounted Panel Runs with Worksurface/Overhead Storage Loading**

**Wall-Mounted Panels with Worksurface/Storage Loading & Returns on One Side**

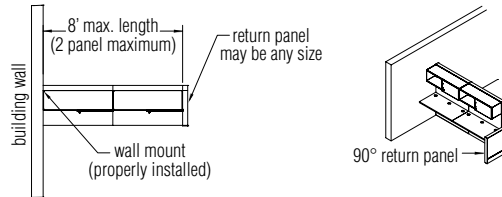

- Worksurface/Storage loading is not allowed for use with wall mount, unless an approved return is used on the loaded side in conjunction with the wall mount. If an alternate return is used, all planning guidelines for the appropriate loading condition must be followed.

**Freestanding Panel Runs with Worksurface/Overhead Storage Loading**

**Panels with Worksurface/Storage Loading & Returns on One Side**

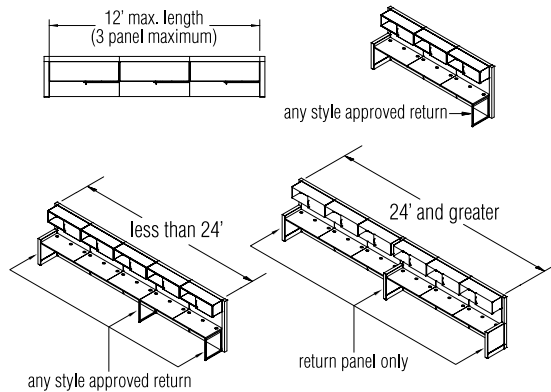

- Maximum run: 3 panels, 12' maximum run length.
- Main run length less than 24' can use any style of approved return (see example). Also see rules for panel returns and use of edge support brackets (page 16).
- A main run of 24' or greater, **MUST USE A RETURN PANEL** every 12' for stability (see example). **Note:** No other return style is allowed.
- Worksurfaces can be 22", 24", or 30" deep. However, 18" worksurfaces are not allowed.
- Worksurfaces must be connected to adjacent worksurfaces using the appropriate splice plate.
- For maximum rigidity, 24" & 30" deep worksurfaces must use worksurface edge supports with return panels of equal length. See rules for panel returns and use of edge support brackets (page 16).

**120° Panels with Worksurface/Storage Loading & Returns on One Side**

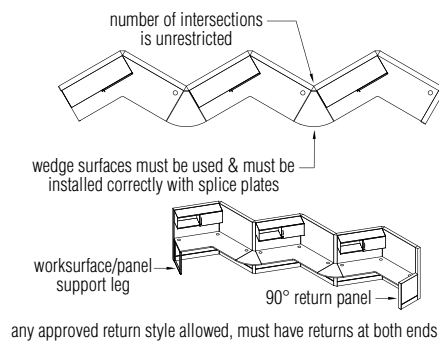

- The maximum panel length and number of panels are unrestricted.
- Worksurfaces may be any depth, and must be planned so they are continuous down each side, and are spliced together.
- Panels must be a minimum of 36" wide.
- Approved returns must be used at each end of the run on the last worksurface.

**Wall-Mounted Panel Runs with Worksurface/Overhead Storage Loading**

**Wall-Mounted Panels with Balanced Worksurface/Storage Loading & Returns on Both Sides**

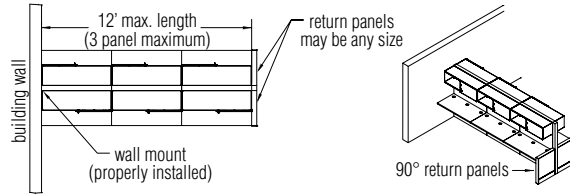

- Worksurface/Storage loading is not allowed for use with wall mount, unless an approved return is used on the loaded side in conjunction with the wall mount. If an alternate return is used, all planning guidelines for the appropriate loading condition must be followed.

**Freestanding Panel Runs with Worksurface/Overhead Storage Loading**

**Panels with Balanced Worksurface/Storage Loading & Returns on Both Sides**

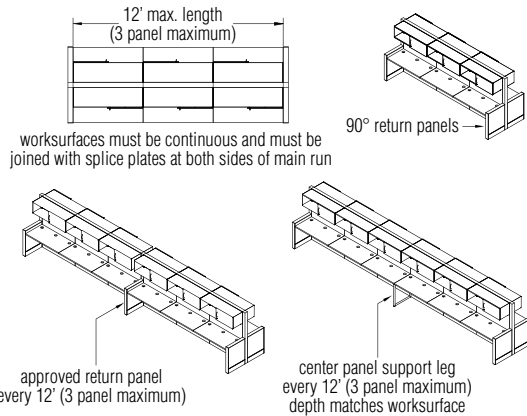

- Maximum run: 3 panels, 12' maximum run length.
- Worksurfaces can be any depth; however, they must be connected to adjacent worksurfaces by the appropriate splice plate.
- Main run may be of any length provided an approved return occurs every 12' along main run panel.
- A center panel support leg may function as a return in this configuration.
- For maximum rigidity, 24" and 30" deep worksurfaces must use worksurface edge supports with return panels of equal length. See rules for panel returns and use of edge support brackets (page 16).

**120° Panels with Balanced Worksurface/Storage Loading & Returns on Both Sides**

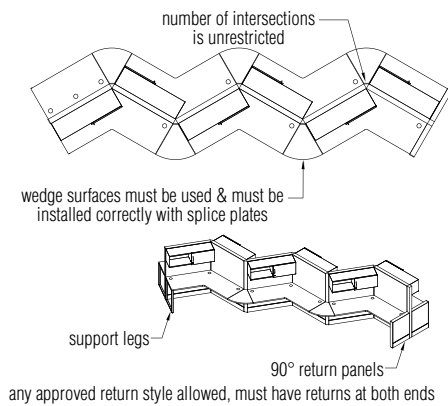

- Maximum panel length and number of panels are unrestricted.
- Worksurface may be any depth, must be planned so they are continuous down each side, and spliced together.
- Panels must be a minimum of 36" width.
- Approved returns must be used at each end of the run on the last worksurface.

**Freestanding Panel Runs with Worksurface/Underhead Storage Loading**

**Panels with Worksurface/Underhead Storage Loading and Returns**

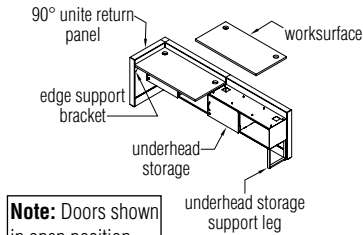

**Note:** Doors shown in open position

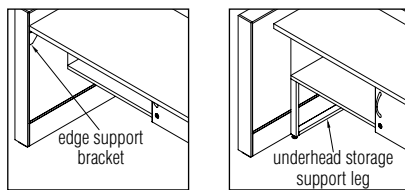

**Note:** Doors shown in locked position

- Underheads restrict leg room and are typically used in adjacent, open working areas.
- Underheads **cannot** be used in conjunction with overheads.
- Underheads support worksurfaces and replace cantilever brackets.
- Underhead storage support legs cannot be used as panel support. At least one end of the panel run must have a valid 90° Legion Return Panel.
- Underhead storage support legs are specified separately.
- Underheads attach on-module only.
- Multiple underheads can be installed on a panel run. Maximum length of the run is 12'.
- Adjacent underhead cabinets must be joined with a metal splice clip similar to overheads.
- **Recommendation:** If 24" worksurfaces are used, then 24" wide return panels are recommended at the end of the underhead to allow use of edge support bracket for extra support.
- Underhead located at a return panel must have either a worksurface edge support bracket or an underhead storage support leg.
- Underhead doors slide from side-to-side. Door locks on right side only. Consider lock position when ordering. Left side locking available as special only.

**Panels with Worksurface/Underhead Storage Loading and Returns with 72" Wide Adjacent Underheads**

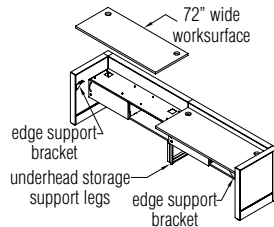

- Adjacent 72" wide underheads requires underhead storage support legs at the connection regardless of worksurface connection due to the long unsupported length.
- Two 72" wide adjacent underheads require underhead storage support legs at the adjacent connection.

**Panels with Worksurface/Underhead Storage Loading and Returns with Runs of 3 Adjacent Underheads**

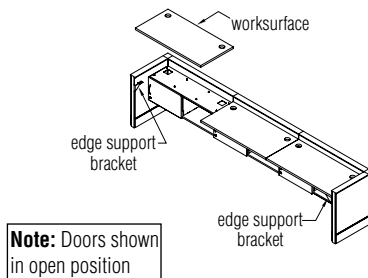

**Note:** Doors shown in open position

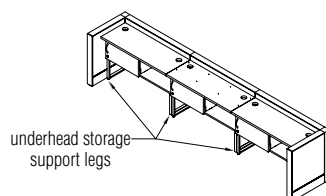

- Adjacent underheads **do not require** underhead storage support legs if both worksurface ends are attached with edge support brackets.
- Underhead storage support legs are not required in this configuration but are recommended.
- Adjacent underheads **require** underhead storage support legs if the worksurface at either end is not attached with edge support brackets.

**Freestanding Panel Runs with Worksurface/Underhead Storage Loading (cont.)**

**Panels with Worksurface/Underhead Storage Loading and Returns with Runs of Three Adjacent Worksurface but only One or Two Underheads**

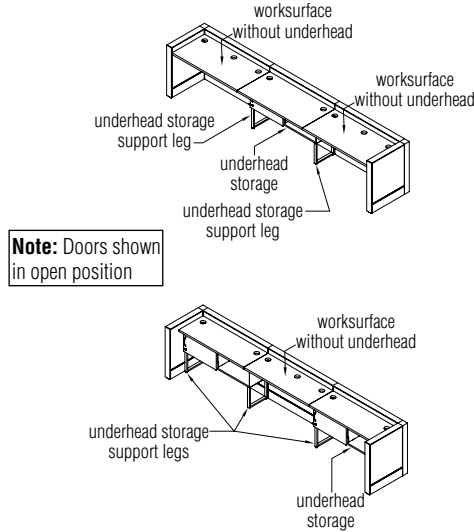

- One underhead at center of a three panel run requires underhead storage support legs at both ends of underhead.
- Underheads on both ends of a three panel run require underhead storage support legs at the center. Return ends depend whether edge support brackets are used.
- Approved cantilevers and splice plates required for surfaces without underheads.
- When edge support brackets are not used, underhead storage support legs are required at return.

**Panels with Worksurface/Underhead Storage Loading and Returns with Perpendicular Worksurfaces**

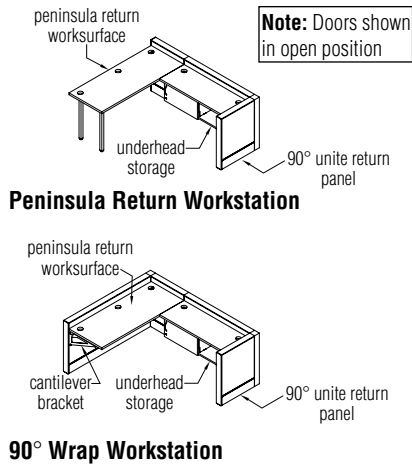

- No underhead storage support leg required if surface is perpendicular and fully supported; such as a peninsula “return” or 90° wrap workstation.
- Approved cantilever and splice plate required on the adjacent perpendicular surface.
- Return panel can be replaced with legs as peninsula is a valid return on one end.

**Preconfigured Stacking Panels**

**Stacking Panels**

Basic Model: LSTS & LSTF

Stacking Panels can be added to any height panel and increase the height by 16". Panels may be stacked to maximum of 80" (one 16" Stacking Panel on a 64" panel). Stacking Panels are available with glass, steel and perforated steel inserts which are assembled with an exposed aluminum frame. Stacking sections are also available with standard Legion acoustic tiles, marker-board and slat tiles which are assembled over a steel sub-frame.

Height: 16"

Width: 24", 30", 36", 42", 48", 54", 60" & 72" (split tile on 72")

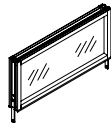

**Glass**



**Steel**

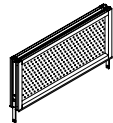

**Perforated Steel**

**Aluminum Frame**

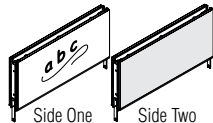

**Markerboard & Fabric**

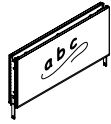

**Markerboard**

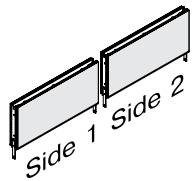

Fabric (2 sides)

**No Frame**

- Hang-on storage & accessories are not allowed on any stacking panels. **Note:** Stacking panels do not contain slots.
- 48" thru 72" wide stacking panel may span two panels.
- Only one stacking panel allowed on a base panel.
- Transaction & counter top surfaces are not allowed on any stacking panel.
- Glass dividers are not allowed on any stacking panel.
- Power is not available in stacking panel.
- Cannot use a top infeed on an aluminum frame style stacking panel (glass, steel and perforated steel inserts).
- Top Infeed can be used on the all stacking panels that do not have the aluminum frame.
- May be specified with pre-configured stacking intersections or standard pre-configured intersections. **Example:** For a 16" stacking panel on a 64" panel, specify either a 16" stacking intersection or an 80" standard intersection.

**Panel Mounted  
 Component  
 Capacities**

**Vertical Stacking of On-Module Components**

The following charts are designed to provide a quick reference for vertical hang-on clearance for Legion panels. The first table indicates the vertical space available to hang components, listed by panel height.

Note: The hang-on capacity is referenced from the top of the panel. The lowest hang-on component can be 10" above the ground. The hang-on capacity of each panel is less than the height of the panel because of the panel base.

Panel Height	Actual Hang-On Space
32"	22"
40"	30"
48"	38"
56"	46"
64"	54"

The next table indicates the vertical requirements of the listed components. In addition to the actual dimension, any special clearances are listed.

Product	Vertical Size	Special Notes
Worksurface with Standard Cantilever	11"	
Worksurface with Design Bracket	8"	
Worksurface with Support Leg	20" for 30" WS HT	Uses lowest 20" of hang-on space for 30" worksurface height. Uses lowest 16" of hang-on space for 26" worksurface height.
Vini Panel Supporting Storage with Worksurface	20"	Uses lowest 20" of hang-on space for 30" worksurface height.
Countertop with Standard Brackets	8"	Uses 8" inside panel plus 1" worksurface above top cap.
Countertop with ADA Brackets	6" Outside 3" Inside	Uses 6" on the outside of panel plus 1" worksurface above the top cap. Uses 3" on inside of panel, works on 32" high panel with 30" worksurface mounting.
Vini Overhead	15"	
Vini Overhead with Upmount Bracket	8"	Uses 8" of hang-on spacing, overhead unit extends 15" above bracket/top cap height.
Venus Overhead	17"	
Venus Overhead with Upmount Bracket	11"	Uses 11" of hang-on spacing, overhead unit extends 17" above bracket/top cap height.
Universal Overhead	17"	
Universal Overhead with Upmount Bracket	11"	Uses 11" of hang-on spacing, overhead extends 17" above bracket/top cap height.
Tackboards	12", 16", 30" & 46"	Two tackboards cannot be hung adjacent to each other on the inside of intersections.
Markerboards	32"	Two markerboards cannot be hung adjacent to each other on the inside of intersection.
Tool Rail	5"	Two tool rails cannot be hung adjacent to each other on the inside of intersection.



**POWER &  
RECEPTACLE  
MANAGEMENT**

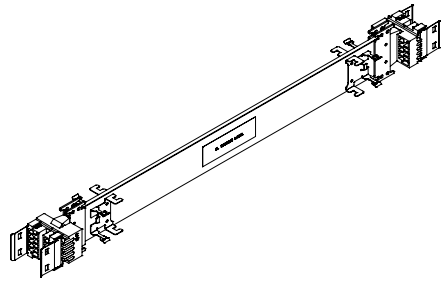

Rigid Wireway

**Power Jumpers  
and Pass-Through  
Harness**

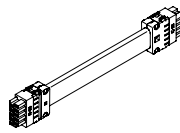

In-line Panel Jumper  
(12" length)

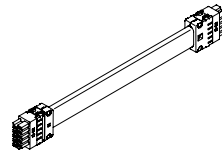

Intersection Panel Jumper  
(15.5" length)



Vertical Panel Jumper  
(38.5" length)

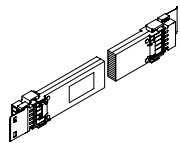

Steel Pass Through Harness  
24" & 30" length

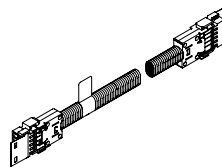

Power Pass Through Harness  
36" - 72" length

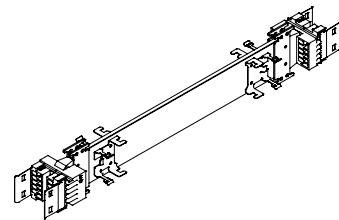

Power Pass Through Harness  
(Rigid Wireway)

**Power Infeeds**

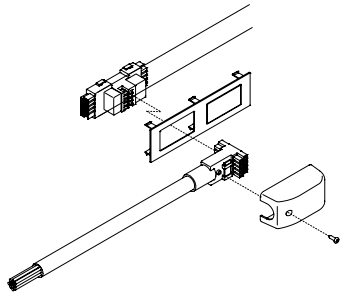

Standard Base Infeed  
 with Bezel for Raceway Base

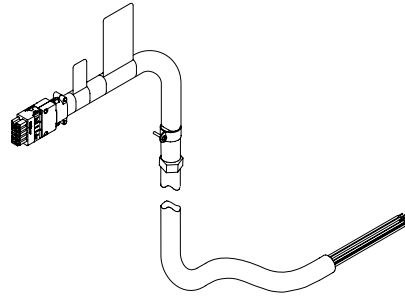

Base Infeed for  
 Elevated/Raised Base

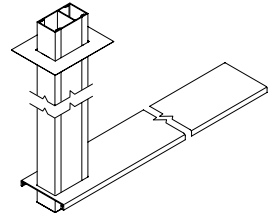

Top Feed with 7' or 10'  
 Pole & Top Cap

**Power & Data  
 Accessories**

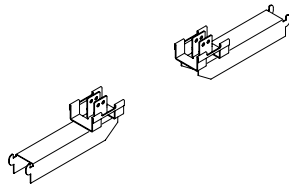

Beltway-Height  
 Harness Mounting Kit

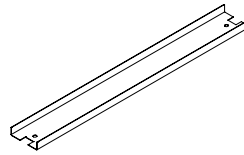

Raceway  
 Cable Trough

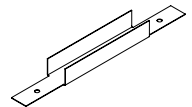

Beltway  
 Cable Trough

**Receptacles**



15 Amp Duplex Receptacle  
 for Beltway



15/20 Amp Duplex  
 Receptacle  
 for Beltway

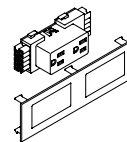

15 Amp Duplex Receptacle  
 with Bezel for Raceway

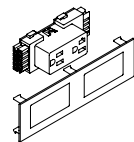

15/20 Amp Duplex  
 Receptacle with Bezel  
 for Raceway

## Electrical Planning Introduction

### 810 10-Wire System

Legion utilizes the 810 10-wire system. The 810 system is available in two different 10-wire configurations:

6-2-2: 6-hot wires, 2-shared oversized neutral wires, 2-ground wires (1-isolated and 1 common ground)

4-4-2: 4-hot wires, 4-independent neutral wires, 2 ground wires (1-isolated and 1 equipment ground)

**Note:** 6-2-2 and 4-4-2 configurations require unique 810 modular components such as jumpers & rigid wireways. Since wires are not visible, component for both configurations appear identical. UL color coded labels either green (6-2-2) or light blue (4-4-2) are attached to components for identification.

### 6-2-2 and 4-4-2 Comparison

The 6-2-2 system provides 6-circuits; 3-convenience and 3-isolated ground circuits (sometimes referred to as a 3 + 3 configuration). The six circuits share two oversized grounds. The 4-4-2 system provides only 4-circuits but allows "independent" neutrals for each circuit. Some older buildings only accommodate 4-2-2 wiring which can be supported with the 6-2-2 (or 4-4-2 check) system. The 6-2-2 wire configuration is arguably more flexible as it allows more workstations than the 4-4-2.

### Number of Workstations

The number of workstations is typically computed per infeed. The number of workstations supported per infeed is based on the power draw at each work station. Multiple infeeds can be used in a space plan.

The factor that determines on how many workstations can be used per infeed is the number of powered devices used in each workstation. Specifically, the number of amps each device will draw.

There is a tag on every UL listed electrical appliance that shows how many amps the appliance will draw (ex: 1.5A = 1-1/2 amps). The total number of amps will determine how many appliances each infeed circuit can handle (recall: 6-2-2 has 6 circuits / 4-4-2 has 4 circuits).

Typical building power is protected by either 15 amp or 20 amp breakers or fuses for each circuit. Therefore, the target is to load each circuit with less total amps than the breaker or fuse. Example: 16 amps total on a 20 amp circuit provides a 4 amp cushion.

### Examples (20 amp circuit)

**Note:** The following examples are per circuit (6-2-2 has 6 circuits / 4-4-2 has 4 circuits)

1. Device draws 2 amps each: 16 amps divided by 2 amps = 8 workstations max
2. Device draws 2.5 amps each: 16 amps divided by 2.5 amps = 6 workstations max
3. Device draws 3 amps each: 16 amps divided by 3 amps = 5 workstations max
4. Device draws 3.5 amps each: 16 amps divided by 3.5 amps = 4 workstations max
5. Device draws 4 amps each: 16 amps divided by 4 amps = 4 workstations max

### 8-wire 4-2-2 Buildings

Both 6-2-2 and 4-4-2 wire configurations use 10 wires. However, some buildings may be equipped with 8 wires (4-2-2). The 6-2-2 wire configuration can still be used. The electrician will not power up circuits #5 and #6. Four circuits will be available; 3-convenience and 1-isolated ground. Before starting the space plan, determine what configuration of building wiring will be supplied.

### 6-2-2 and 4-4-2 Compatibility

6-2-2 and 4-4-2 modular components cannot be used together. Parts for each system are "keyed", so they can only be connected to the same system. It is doubtful there would be a situation where this would be needed. Most building will be wired one way or the other, but not both.

### 810 10-wire 6-2-2 and 4-4-2 Identification

The 6-2-2 components have a green UL label on each part and the 4-4-2 components have a light blue UL label. These colors are different than any other colors used on other systems furniture electrical parts.

**Electrical Planning  
Introduction (cont.)**

**Electrical Requirements and Compliance**

Plan circuits based on the actual amperage draw of known equipment.

- Be aware of the NEC requirement that limits circuit capacity to 80 percent (16 amps) for circuits with continuous operating loads (more than 3 hours, e.g.; lighting, computers, etc.).
- Never exceed maximum capacities or local code limitations.
- KNOW YOUR LOCAL CODES! They always take precedence.
- Determine the equipment needs for any dedicated or isolated ground circuits and pan circuit loading and power feeds accordingly.
- Circuit loading should be balanced. Plan a circuit load that is within 50 percent of the loads on the other circuits. (Balance does not apply to dedicated circuit.)
- Place receptacles for known equipment only, never exceeding maximums allowed per code (13 duplexes per circuit, or local code restrictions, whichever is smaller).
- If any single piece of equipment draws more than 60 percent of the available amperage of a circuit, it must be the only device connected to that circuit. Example: a device draws 15 amps on a 20 amp circuit (75%); therefore, nothing else can be connected to the circuit the device is on.
- Always have your electrical layout plans reviewed by a licensed electrician or electrical inspector to ensure that they meet all code requirements.

**Priority Sequence for Electrical Layout**

1. Plan circuits based on actual amperage needs.
2. Plan for future growth and additions.
3. Consider and plan for large loads separately.
4. Balance loads across shared circuits.

**Power and Receptacle Management**

**Power Locations**

Modular components are used to distribute power. Power is installed at either the base raceway or at above-worksurface beltline height with up to 8 receptacle locations. Cables can also be routed along the tops of panels, through the interior of the panels, along the base, along beltway height, or vertically in the open channels adjacent to the intersection locations.

**Base Raceway**

- Base power can be specified on one or both sides of a panel.
- All Legion panels 30" or greater widths, with a steel raceway base, feature two knockouts per side allowing up to four duplex receptacles per panel.
- All 24" panels feature a single knockout per side which accepts a single duplex receptacle allowing up to two duplex receptacles per panel.

**Note:** Elevated base panels are limited to power distribution at beltline height only.

**Beltline**

- Beltline power can be specified on one or both sides of a panel.
- Beltline power is available on panels 40" and higher (not 32" high).
- Tiles are shipped pre-assembled with bezel plates and bezel plate covers.
- 30" or greater widths feature two bezel plates per side, allowing up to four duplex receptacles per panel.
- 24" panels feature a single bezel plate per side, which accepts a single duplex allowing up to two duplex receptacles per panel.

**Note:** Tile-to-floor "tiles" do not feature cutouts or bezel plates.

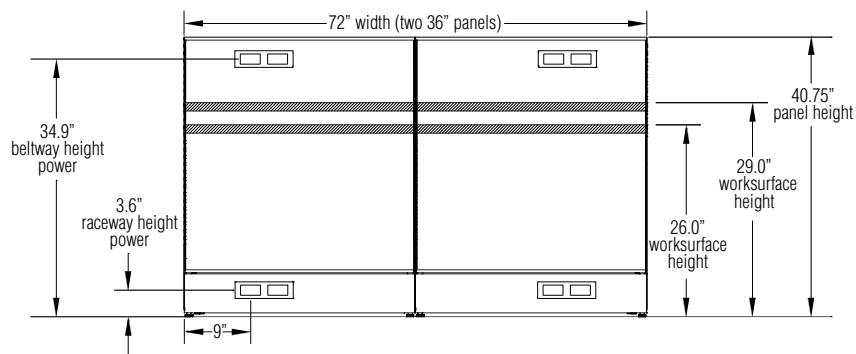
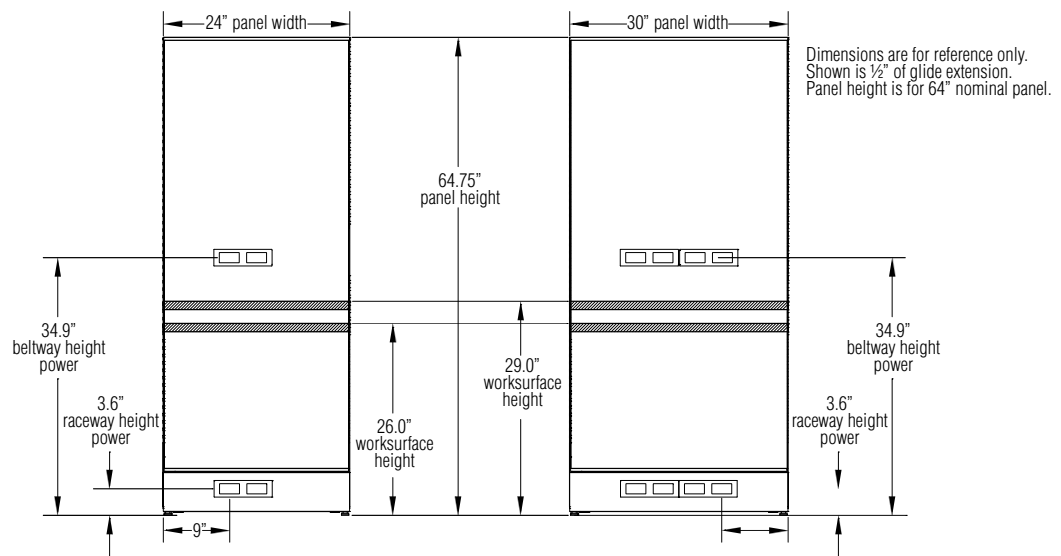

Dimensions above are for reference only.  
 Shown is 1/2" of glide extension.  
 Panel height is for 40" nominal panel.

**Power and Receptacle Management (cont.)**

**Rigid Wireways**

Model Numbers: 6-2-2 UWT6WW.size, 4-4-2 UWT4WW.size

Widths: Accommodates all Legion panel widths.

Rigid Wireways are the primary electrical component for distributing power through panels. Rigid Wireways must be ordered separately and are specified by the width of the panel in which they are installed.

There are four plug-in port locations (see below, 2 labeled "WA", 2 labeled "WC") on every Rigid Wireway. Ports allow plug-in connection with various other electrical components. To aid in specifying mating electrical components, port locations are identified in the graphics below. Included in component descriptions that follow are guidelines as to what can and cannot be plugged into the various ports.

**Example:** A base feed has a C terminal. It can plug in where ever there are WC (Wireway C) terminals on the rigid wireway.

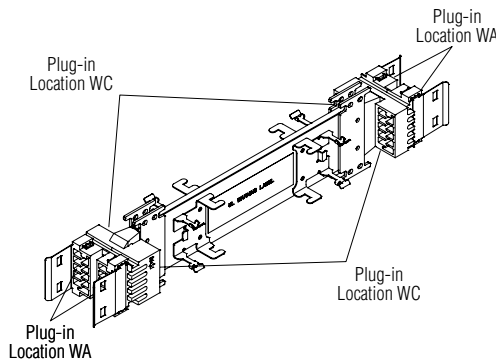

- Rigid wireway accepts power infeeds, horizontal jumpers, vertical jumpers, and duplex receptacles with simple modular snap connection (no additional connection hardware required).
- Rigid wireway are non-directional and can accept power from either orientation.
- Ends of rigid wireways have the letter "N" and an arrow pointing "UP" to indicate the proper installation orientation.
- 6-6-2 rigid wireways have a green UL label and 4-2-2 rigid wireways have a light blue UL label.

Plug-in Location Key Chart	
<b>A</b>	Most Electrical Accessories
<b>C</b>	Circuit Receptacles
<b>WA</b>	Wireway Accessory
<b>WC</b>	Wireway Circuit

**Note:** Legion 24" rigid wireways are constructed the same as all Legion wireways with two circuit (ie- receptacle) ports on each end. However, Legion 24" wide powered panels only provide access (tile cutouts) to one end. This is due to limited space required by the horizontally shaped bezel plates. (Reference: PowerWorks and System XXI - 24" wireways have two ports on one end only).

**Power and Receptacle Management (cont.)**

**Base or Beltway Mounted Rigid Wireways**

Rigid Wireways accept power infeeds, horizontal jumpers, vertical jumpers, and duplex receptacles with simple modular snap connection (no additional connection hardware required). Rigid Wireways are non-directional and can accept power from either orientation.

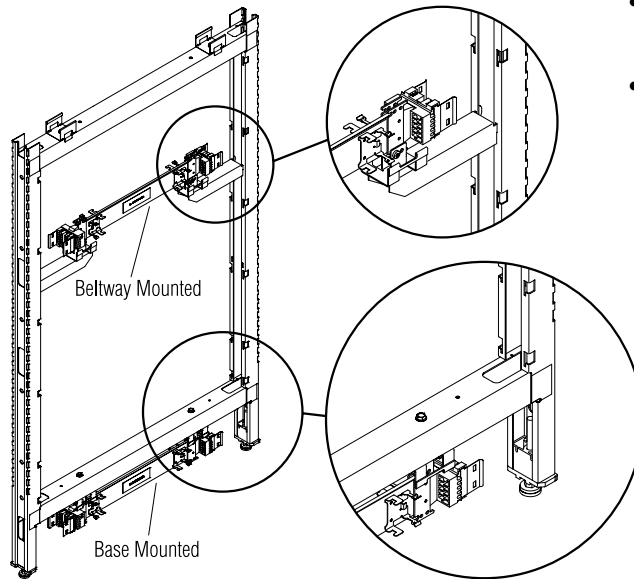

- Base mounting requires brackets which are pre-assembled to the base horizontal rail whenever a raceway is specified.
- Beltway mounting requires a harness mounting kit UETBWM at beltline height.

**Power Jumpers**

**Horizontal Panel Jumpers**

Model Numbers: UET6PJINL, UET4PJINL, UET6PJINT, UET4PJINT

Horizontal Jumpers are used to pass power from panel to panel between rigid wireways. Two jumper lengths are available.

**12" In-Line (INL) Panel Jumper**

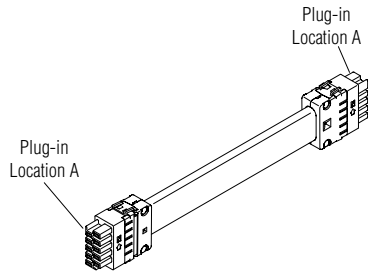

- 12" length and used for all In-Line panel to panel connections of similar height.
- In-line jumpers cannot be used in any other locations or conditions.

**15.5" Intersection (INT) Panel Jumper**

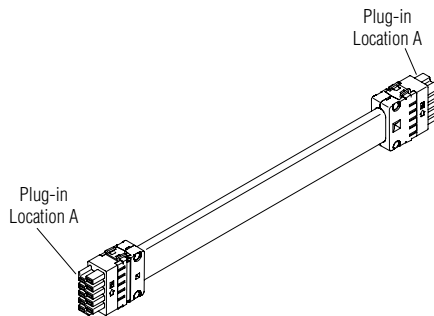

- 15.5" length and used for all panel to panel connections requiring an intersection condition (90°, 120° or 180°).

**12" (INL) Panel Jumper**

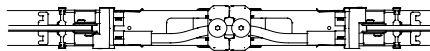
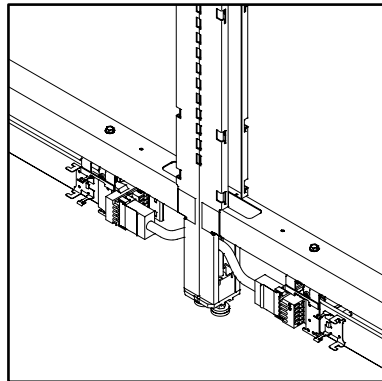

**12" Panel Jumper, 180° In-Line Intersection**



Power Jumpers  
(cont.)

15.5" Intersection (INT) Panel Jumpers

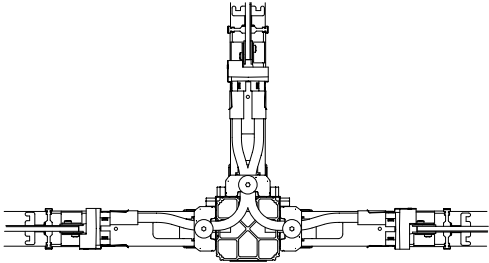
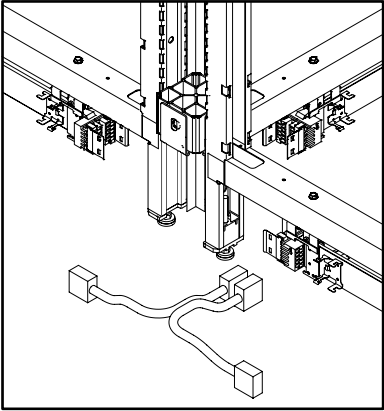

15.5" Panel Jumpers, 90° 3-Way Intersection

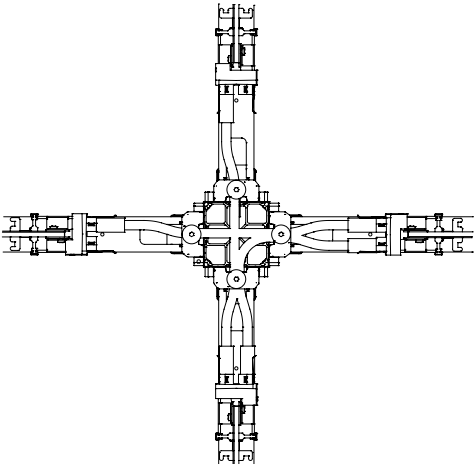
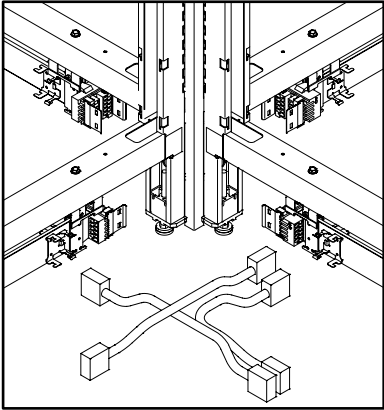

15.5" Panel Jumpers, 90° 4-Way Intersection

**Power Jumpers  
(cont.)**

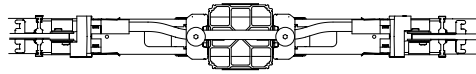
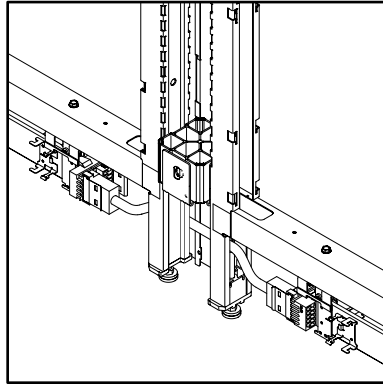

**15.5" Panel Jumper, 180° In-Line Intersection with Modular Spacer**

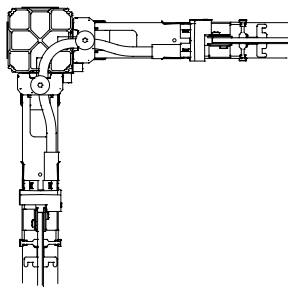
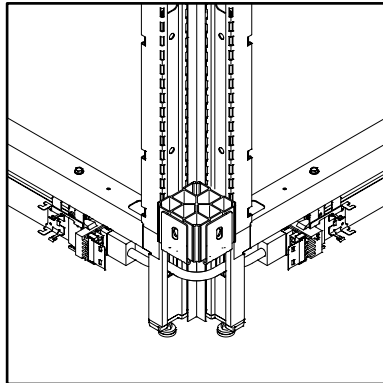

**15.5" Panel Jumper, 90° Corner (2-way) Intersection**

**Power Jumpers  
(cont.)**

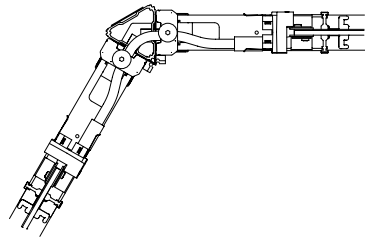
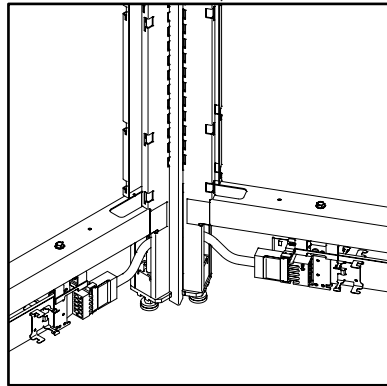

**15.5" Panel Jumper, 120° 2-Way Intersection**

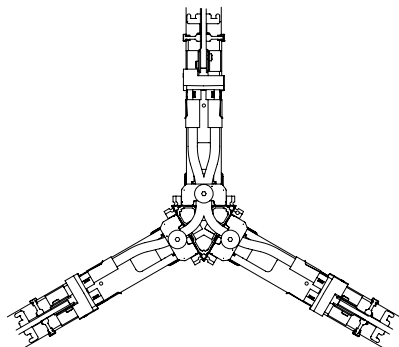
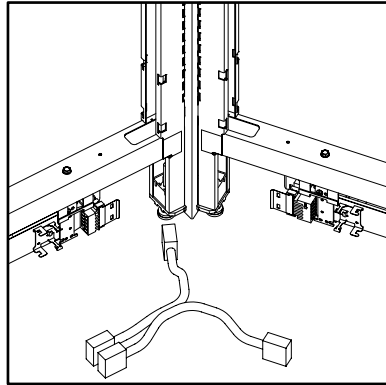

**15.5" Panel Jumpers, 120° 3-Way Intersection**

**Power Jumpers  
(cont.)**

**Vertical Jumpers**

Model Numbers: UET6VJ, UET4VJ

Vertical Jumpers pass power vertically between panel base and beltway. The jumper consists of a flexible corrugated steel conduit with 10 wires. A Vertical Jumper plugs into either end of the rigid wireway.

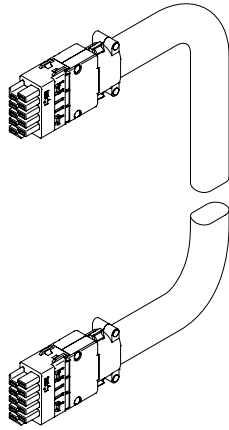

- 38 1/2" length.
- Power can only pass vertically within a panel.
- Vertical jumpers are non-directional.

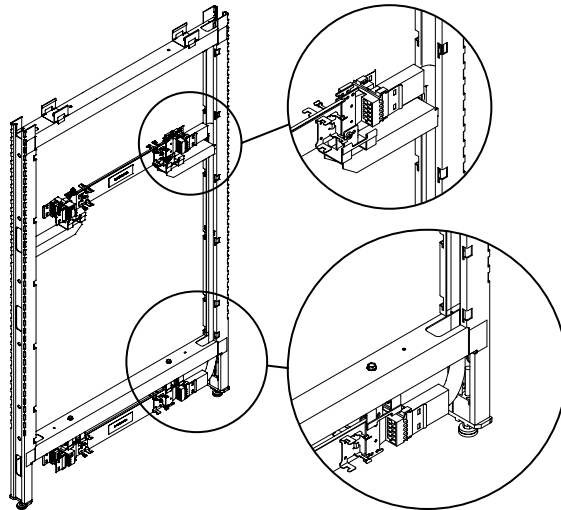

**Power Jumpers  
 (cont.)**

**Power Pass Through Harness**

Model Numbers: UET6PP.size, UET4PP.size

Width: Accommodates all Legion Panel widths

Power Pass Through Harness provides continuation of power between two powered panels. Consists of a steel conduit with 10 wires. The Power Pass Through Harness is specified by panel width and panel-to-panel jumpers plug into the ends. However, the Power Pass Through Harness does not provide receptacle ports.

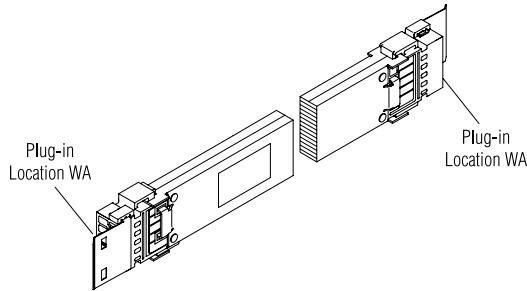

**Power Pass-Through Harness  
 24" & 30" length**

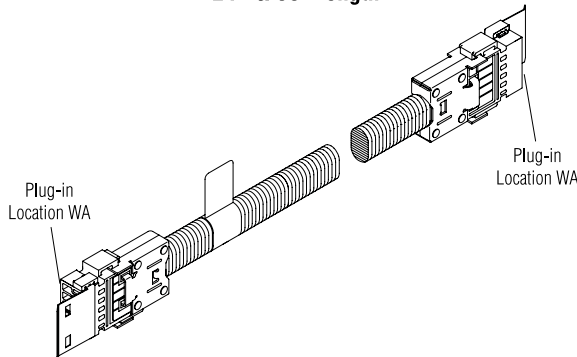

**Power Pass Through Harness  
 36" & 72" length**

- Can be used at beltway or raceway locations.
- Location should not already contain a rigid wireway.  
**Note:** Rigid wireway can function as a power pass through. See "Power Pass Through (Rigid Wireway)" below.
- Not compatible with elevated base.
- Harness does not include receptacles, which are specified separately.
- Power pass through harness is non-directional.
- Length is specified the same as corresponding rigid wireway.
- Requires 12" In-Line or 15.5" Intersection panel-to-panel jumper on each end.
- Harness can hang inside Legion panels.
- Multiple panels can be connected with a power pass through harness specified for each panel. However, the appropriate panel-to-panel jumper must be specified at each panel intersection condition (in-line or intersection).

**Power Pass Through (Rigid Wireway)**

Model Numbers: 6-2-2 UWT6WW.size, 4-4-2 UWT4WW.size

Width: Accommodates all Legion panel widths

Rigid Wireways can be specified instead of the Power Pass Through Harness models as an alternate power pass through. Monolithic panels can be specified that do not contain beltway power cut-outs. Since the Rigid Wireway is modular, receptacles are simply omitted. 12" In-line or 15" intersection jumpers are required to connect Rigid Wireways from panel to panel. The advantage to this method is future reconfiguration in case receptacles are required at a later date. Legion tiles can be replaced with powered tiles that contain cut-outs and bezel plates.

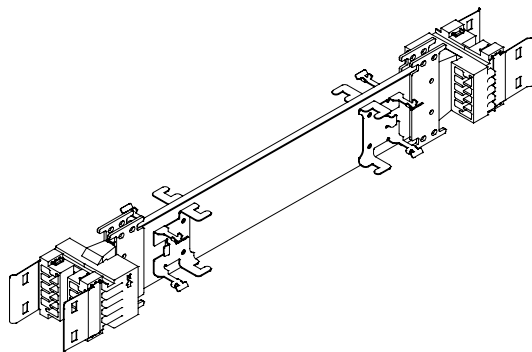

- Can pass power at beltway or base raceway.
- Beltway requires harness mounting kit UETBWM.
- Location should not already contain rigid wireway.
- Rigid wireway does not include receptacles.
- Length is specified by corresponding panel width.

**Power Infeeds**

Power Infeeds are available at the base or top of a Legion panel. Standard Base and Elevated Base Infeeds contain unique components that are not interchangeable.

**Standard Base Infeed with Bezel for Raceway Base**

Model Numbers: UET4RBFU, UET6RBFU

Standard Base Infeed includes a liquid-tight flexible conduit with 10 wires and a modular end that plugs into a base receptacle port.

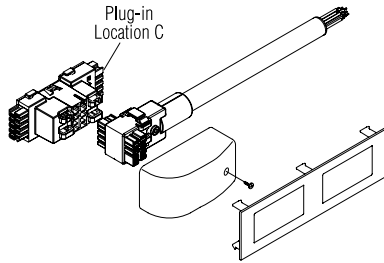

- Includes Legion bezel with filler plate that can be removed to include a modular furniture data jack.
- For use with standard bases only.
- Base feed plugs into a single receptacle in the base of a standard base panel.
- Unit is non-handed and can be routed to the right or left on either side of a panel.
- Base feed can be fed into the power system at any receptacle along the run.
- Infeed conduit is 72" long.

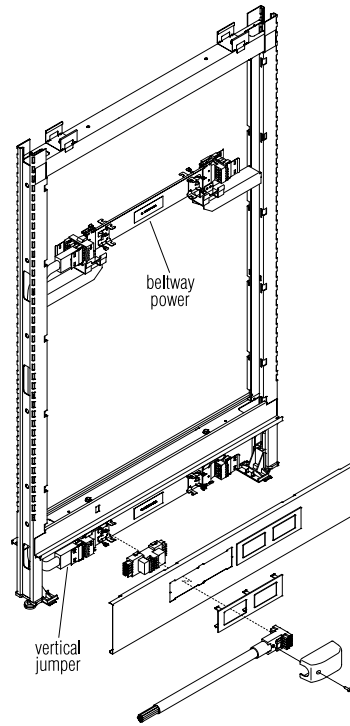
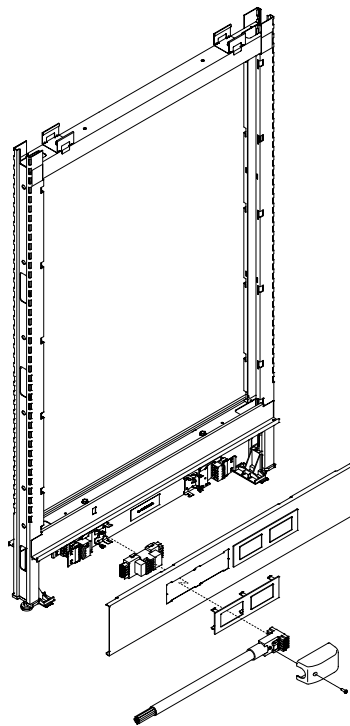

When a Standard Base Infeed is located between a panel and the building wall, the panels must be located at least 1 3/4" away from the wall to provide adequate clearance. Alternately, the base infeed can be connected inside the station and the 6' cable run under the panel. This option requires a minimum of 1" between the panel and the wall for the base feed cable to enter the junction box on the wall.

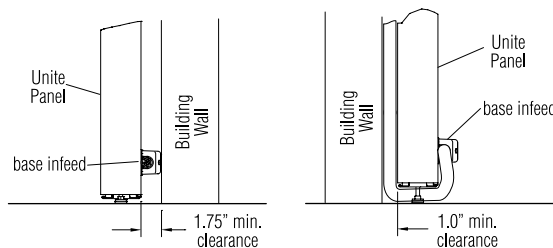

**Power Infeeds  
(cont.)**

**Base Infeed for Elevated Base**

Model Numbers: UET4LBFU, UET6LBFU

Raised or Elevated Base Infeeds includes a liquid-tight conduit that runs up the raised base, through holes at the end of the bottom horizontal and into the rigid wireway at beltway height.

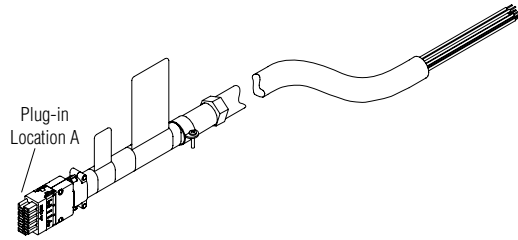

- Infeed plugs into the end of a rigid wireway.
- Infeed does not occupy a duplex receptacle port.
- Infeed conduit is 72" long.
- If the building electrical supply is from a wall source a minimum gap of 1" is required for the power infeed whip.

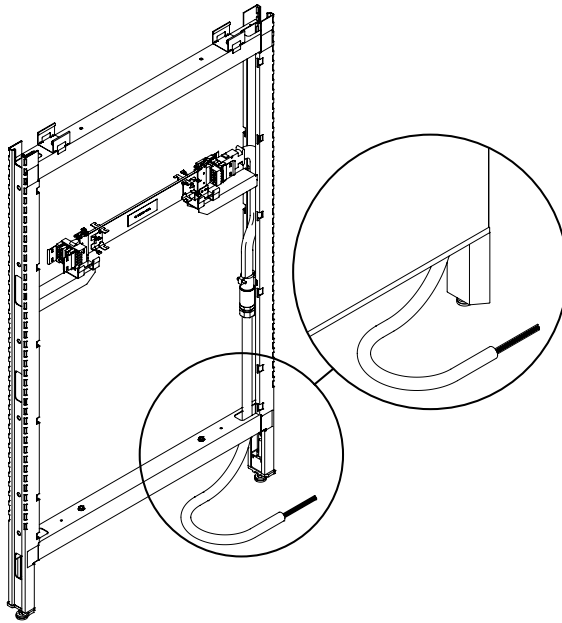

**Power Infeeds  
 (cont.)**

**Top Infeed with 7' or 10' Pole and Top Cap**

Model Numbers: UETF07.size, UETF10.size

Widths: Accommodates all Legion Panel widths

Top Infeed can be specified with or without an infeed power conduit also referred to as an infeed "whip". Specify without an infeed whip in case the Top Infeed is only used to house data cables. When power is specified, a flexible corrugated steel conduit with 10 wires is provided. The conduit runs from the ceiling down an aluminum pole; passing through a hole at the end of the horizontal rail and plugs into the rigid wireway at beltway or base locations. Two cavity pole provides separation of power and data cabling. Each cavity has a snap on cap which allows easy lay-in cable assembly.

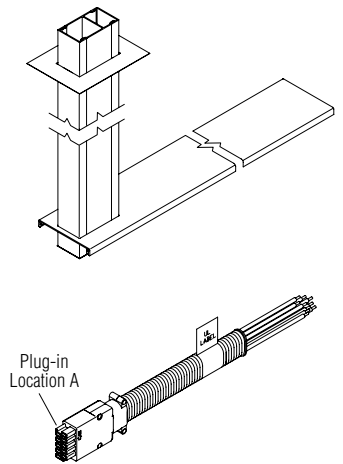

Infeed conduit when power is specified (144" or 216")

**Infeed Pole Height Tables**

7' Infeed Pole	
Panel Height	Maximum Ceiling Height
32"	9' - 0"
40"	9' - 8"
48"	10' - 4"
56"	11' - 0"
64"	11' - 0"
72"	11' - 0"
80"	11' - 0"
10' Infeed Pole	
Panel Height	Maximum Ceiling Height
32"	12' - 6"
40"	13' - 4"
48"	14' - 0"
56"	14' -- 6"
64"	14' - 6"
72"	14' - 6"
80"	14' - 6"

- Top infeed includes a 3-piece, painted aluminum power pole, ceiling trim and top cap. Infeed conduit is provided when power is specified.
- Power configuration must be specified; none, 6-2-2 or 4-4-2.
- When powered, a flexible corrugated conduit with 10 wires is supplied that plugs into the end of a rigid wireway at either beltway or base raceway.
- The data cavity can manage up to 24 CAT 6 data cables.
- Trim color must be specified.
- Top infeed must be specified by length of top cap since a special top cap with cut-out for power pole is provided.
- Infeed, when specified, does not occupy a duplex receptacle port.
- Models available with either a 7' or 10' aluminum power pole that extends from the top of the panel to the finished ceiling. Use tables below to determine length of power pole.
- The 7' power pole ships with a 144" infeed conduit. The 10' power pole ships with a 216" infeed conduit. The following table can be used to determine length of pole.
- Top infeed can be located at either end of a panel.
- For use at top of a panel only.
- Cannot be used with aluminum framed stacking sections that contain inserts such as glass, perforated steel or any insert material.
- Can be used with fabric, markerboard and slatwall stacking sections.



## Power and Data Accessories

### Beltway-Height Harness Mounting Kit

Model Number: UETBEM

Widths: Accommodates all Legion Panel widths

A Beltway-Height Harness Mounting Kit is required to attach a rigid wireway at beltway height. A single kit accommodates all Legion panel widths

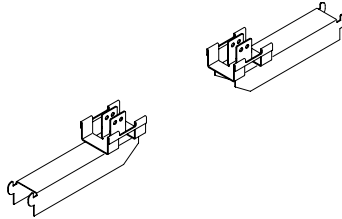

### Raceway Cable Trough

Model Number: UETRT.size

Width: Accommodates all Legion panel widths

Steel Raceway Cable Trough manages cables at raceway. No hardware required for attachment.

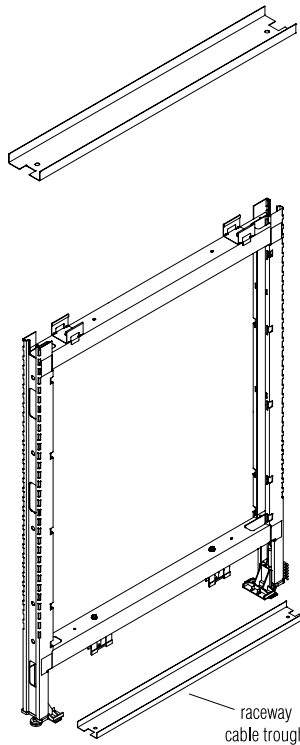

- Black raceway cable troughs snap in place to keep data cables off the floor and is not visible.
- Specify by panel width.

**Power and Data  
Accessories (cont.)**

**Beltway Cable Trough**

Model Number: UETBT.size

Width: Accommodates all Legion panel widths

Steel Beltway Cable Trough manages cables at beltway. Black trough fastens to beltway harness brackets at each end and is not visible. Requires Beltway-Height Harness Mounting Kit (UETBWM) for mounting.

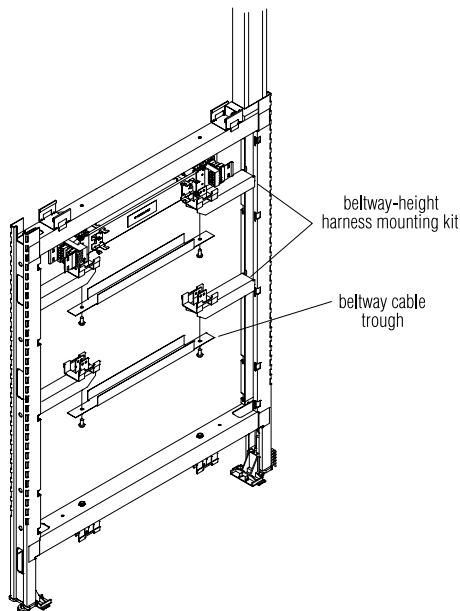
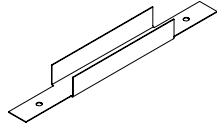

- Beltway data troughs mount to beltway-height harness mounting kit (UETBWM). The beltway mounting kit screws are used to attach the trough.
- Beltway troughs can be used in conjunction with the rigid wireway or without a rigid wireway.

## Receptacles

### 15 or 15/20 Amp Duplex Receptacles for Beltway Use

Receptacle plugs into rigid wireway at beltway to allow appliance use.

- Includes receptacle only. Bezels & filler plates are included with powered panel at beltway and are not specified.
- Receptacles and bezel colors match. Receptacle is molded plastic and available in a variety of colors. Trim color must be specified.
- Receptacles are labeled with circuit identification numbers 1 to 6.
- Isolated ground circuit receptacles are denoted with "I" in the model number and feature an orange triangle after the number (i.e.; 4 D) on the receptacle. **Note:** receptacle is not orange.

#### 15 Amp

Model Number: UET6BRC.(#).color

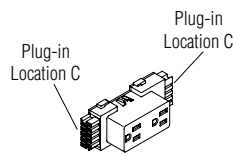

- Rated 15 Amps at 120 volts.
- 6-2-2 available in numbers 1, 2, 3, 4I, 5I, 6I.
- 4-4-2 available in numbers 1, 2, 3I, 4I.

#### 15/20 Amp

Model Number: UET6B20R.(#).color

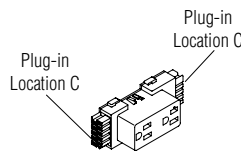

- Duplex receptacle has one 15 Amp plug-in and one 20 Amp plug-in (**Note:** 20 Amp plug-in has a "T" shape plug slot).
- Rated 20 Amps at 120 volts.
- 6-2-2 available in numbers 1, 2, 3, 4I, 5I, 6I.
- 4-4-2 available in numbers 1, 2, 4I (**Note:** not available in 3I).

### 15 or 15/20 Amp Duplex Receptacles with Bezel for Raceway Use

Receptacles plug into rigid wireway at raceway to allow appliance use.

- Includes receptacle, bezel cover and one filler plate. Filler plate can be removed to accept standard "modular" furniture plates or data jacks.
- When installing bezel covers, knock-outs in the steel base raceway tile must be removed.

#### 15 Amp

Model Number: UET6RRC.(#).color

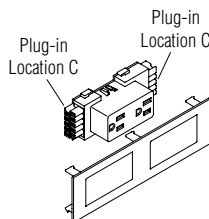

- See Beltway 15 Amp.

#### 15/20 Amp

Model Number: UET6R20R.(#).color

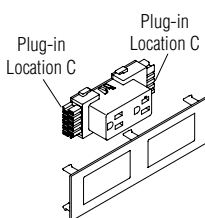

- See Beltway 15/20 Amp.

## Data Cable Management

Legion allows data cables to be routed throughout the framework with simple installation. Data cables are most easily routed after the Legion panel frame work has been set up, but before tiles and trim are installed. Data cables routed through the frame must pass through access holes within the horizontal and vertical posts. Cables can also be routed up vertical posts. Cables are concealed within the Legion panel behind tiles. Data cables can be managed through several locations in the panel.

### Horizontal (see following graphics)

- Under the top cap contained in the top wire trough. Capacity: 20 CAT6 or 5/5E. **Caution:** Do not over fill. Over filling can exert pressure on the top trim.
- Above worksurface height, through rectangular holes in the vertical posts. Capacity: 20 CAT6 or 5/5E.
- Below worksurface height, through rectangular holes in the vertical posts. Capacity: 20 CAT6 or 5/5E. **Note:** 32" high panels do not have a hole "above" the worksurface.
- Along the base raceway, lay-in and around the vertical post (with or without base power). Max Capacity (lay-in): 24 CAT6 or 5/5E (12 on each side of raceway). **Note:** The base raceway can be opened without tools. Push down on the raceway and swing the raceway toward the floor.
- 42" and taller Legion panels provide four levels of data. 84 - CAT6 or 5/5E cables can be managed.
- 32" Legion panels provide three levels of data. 64 - CAT6 or 5/5E cables can be managed.
- When base power is installed, panel-to-panel jumpers occupy the holes in the vertical posts; data cables should be routed around the outside of the vertical posts in a lay in fashion.
- When no base power is installed, data cables can be routed through the holes in the vertical posts. Max Capacity: 20 CAT6 or 5/5E. **Caution:** Do not overfill. Over filling can exert pressure on the base side covers and cause bowing or prevent the cover from closing properly.

### Vertical (see following graphics)

- Through rectangular holes in either end of the horizontal rail and down vertical posts. Capacity: 25 CAT6 or 5/5E.
- Through Legion Power Pole (models - UETF07 and UETF10). Capacity: 25 CAT6 or 5/5E.

### Stacking Sections

- Data cables can pass through fabric stacking sections. Stacking frames are constructed similar to the base frame with a vertical pass through hole in the top horizontal. Data cables can also lay horizontally along the top trough.
- Data cables cannot pass through aluminum frame stacking sections with glass, perforated or steel inserts.

**Note:** Calculations for data cable capacity assume the following size ranges:

- CAT6 = .21 to .25 diameter
- CAT5/5E = .19 to .22 diameter

CAT6 cables are manufactured with larger copper conductors (lower insertion loss = less noise + stronger signal) than CAT5 and may include an internal divider called a "cross-web" that serves to separate the pairs and reduce cross-talk noise.

**Tip:** Use zip ties where possible to help keep cables in place and organized.

### Data Management and Compliance

- Ensure data cables, connections, terminations and installation comply with current standards such as ANSI/TIA and ISO telecommunication standards.

**Note:** When designing and installing structured cabling systems, chose the strongest foundation to support your present and future network applications needs. To ensure support of emerging technologies that utilize the latest advances in signaling schemes, it is critical to be as informed as possible. Trust the TIA and ISO standards developmental groups to specify complete cabling criteria capable of providing applications assurance for tomorrow's technologies today.

**Data Cable Management (cont.)**

**Horizontal**

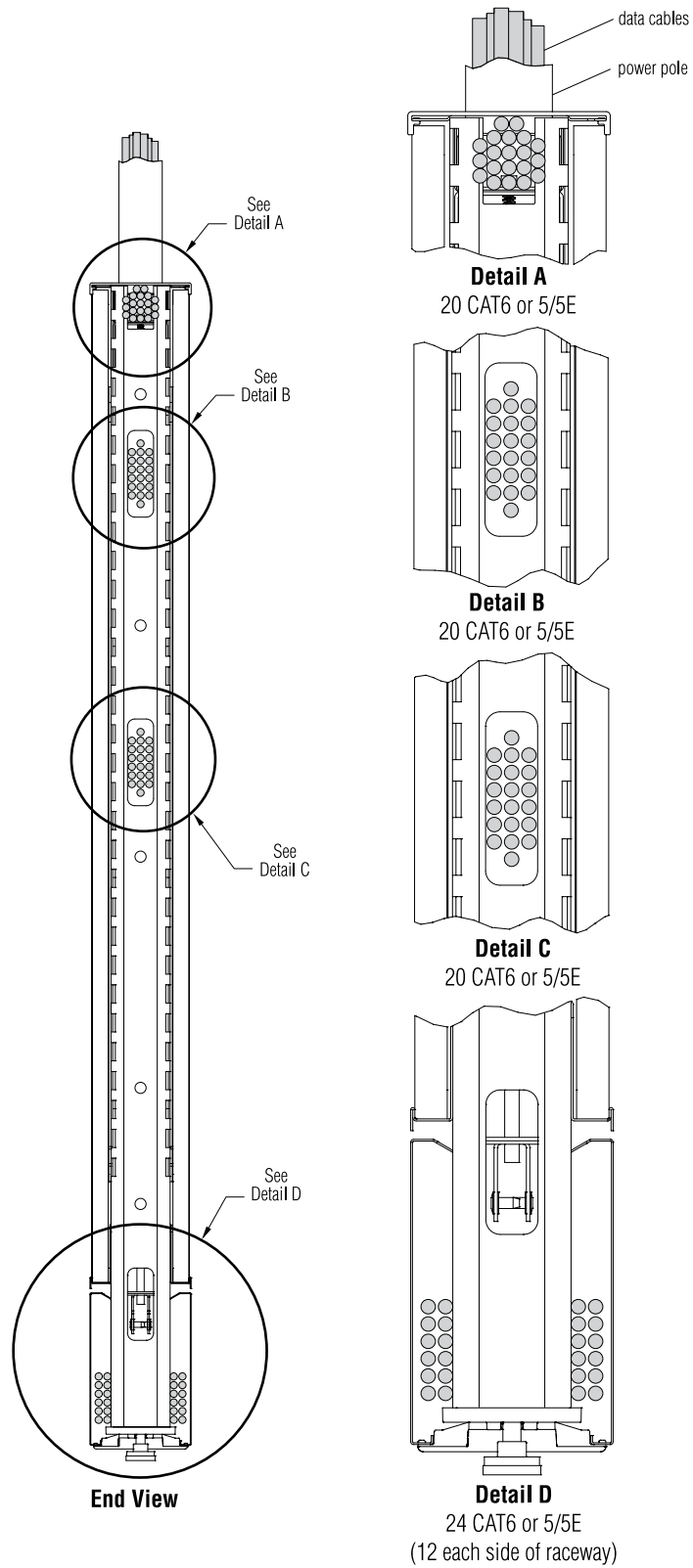

**Data Cable Management (cont.)**

**Vertical**

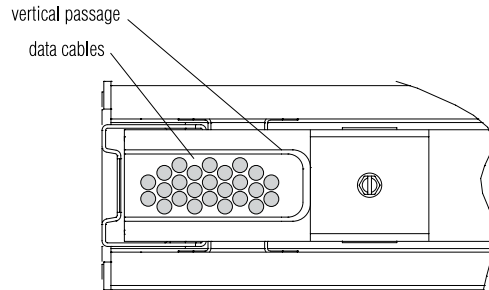

- Cables can run vertical through rectangular holes in either end of horizontal rails and down vertical posts which are open to the inside of the panel frame for easy access.
- 25 CAT6 or 5/5E cables can be routed vertically.

**Power Pole (Vertical)**

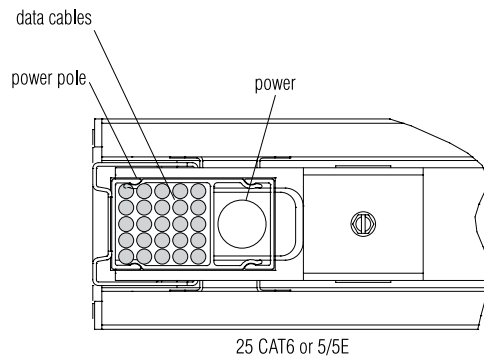

- See "Top Infeed with 7' or 10' Pole and Top Cap" (page 44).
- Power pole is constructed with two cavities for separation of power and data cabling.
- The data cavity can support 25 CAT6 or 5/5E data cables.

**Bend Radius**

Legion panels allow a 1.50" minimum and 2.15" maximum "inside" bend radius at all 90° intersection locations. Sketch below depicts where the cable is placed.

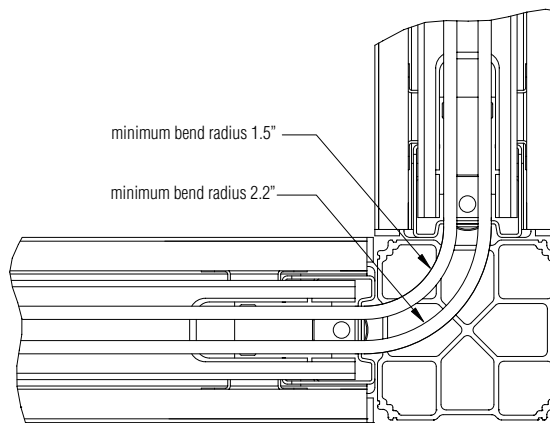

**Data Cabling Bend Radius**

## Data Cable Management (cont.)

### Managing Data Cables Inside Panels

Data cables can be managed with or without optional data troughs. If troughs are not installed, use of tie straps is recommended to help organize cables. A variety of straps can be found at local hardware stores. To help “hang” data cables, soft straps with hook and loop style retention can be used. There are two types of data troughs.

### With Optional Beltway and Raceway Data Troughs

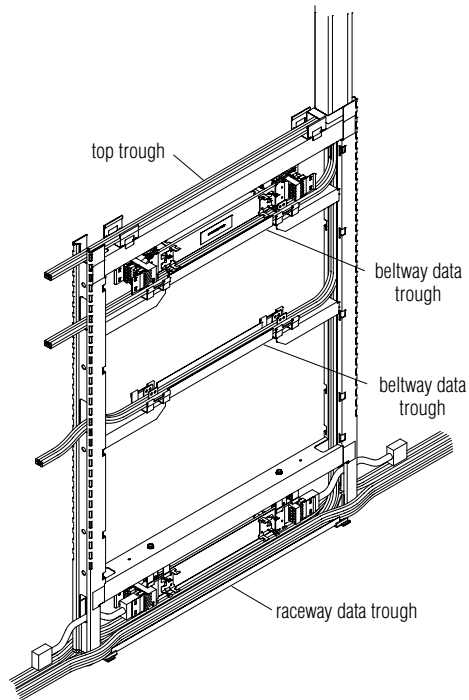

### Without Optional Beltway Data Troughs

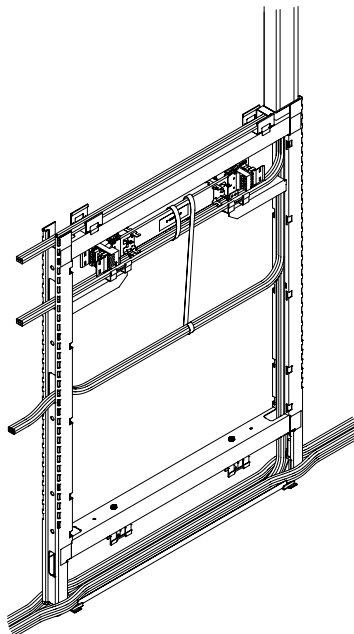

### Reconfiguration

It is common while installing cable to store excess cable in the form of loops within some panels to allow for further reconfiguration of panels and workstations.

**Frequently Used  
 Data Transmission  
 Terms**

**CATx:** Abbreviation for the category number that defines the performance of building telecommunications cabling as outlined by the Electronic Industries Association (EIA) standards. Applies to cables, connecting hardware, and installation. In the context of the 100-ohm UTP (Unshielded Twisted Pair) type of cable used for Ethernet wiring the only categories of interest are Cat3, Cat4, Cat5, Cat5e, Cat6, and Cat7.

**Cat 5e:** Enhanced version of Category 5 that adheres to more stringent standards. It is capable of transmitting data at speeds of up to 1000 Mbps (1 Gigabit per second).

**Cat 6:** Designed to perform at frequencies of up to 250 MHz and offers higher performance for better transmission of data at speeds up to 1000 Mbps. Some properly installed Category 6 cable will also support 10 Gigabit speeds, but likely with limitations on length.

**Cat 6A:** "Augmented CAT6. Latest twisted-pair cable. Operates at frequencies of up to 500 MHz and can support transmission speeds at 10 Gigabits per second (Gbps). Category 6a performs at improved specifications, in particular in the area of alien crosstalk compared to Cat 6, which exhibited high alien noise in high frequencies.

**UTP:** Used primarily for data transmission in local area networks (LANs), UTP network cable is a 4-pair, 100-ohm cable that consists of 4 unshielded twisted pairs surrounded by an outer jacket. Each pair is wound together for the purposes of canceling out noise that can interfere with the signal. UTP cabling systems are the most commonly deployed cable type in the U.S. This is where the category designation first started. Cat 3,4,5,6 etc. first applied only to cables. Most common category cable is four pair.

**RJ:** Remote Jack.

**RJ45:** 8-conductor, compact, modular jack used to terminate UTP data cable. RJ45 jacks are engineered to maintain specific Category 5, 5e, 6, or 6A performance, and therefore must match the category of the cable they are terminating. Connector used for four pair cable. Used mostly for computers.

**RJ11:** Connector used for three pair cables. Not available in Cat 5. Used mostly for telephones and modems.

**Data Line Voltage:** Voltage in data cables varies according to the hardware manufacturer; i.e.; IBM, Hewlett Packard, DEC, Wang. Voltage usually changes continually in data lines but is always around one volt.

**Line Loss:** Loss of signal due to resistance of length of cable and number of connectors. Category 5 guidelines prevent line loss.

**Fiber Optics:** Method of transferring data through a glass filament. Data is carried via light. No electricity, no EMI. Impervious to electrical noise. Bending of the cable is critical. Usually can't have a bending radius of more than 4".

**EMI:** Electro Magnetic Interference - The condition that exists when the electric field of a conductor interferes with the signal of a data carrying conductor.

**Specifications**

**Cat3, Cat4, Cat5, Cat5e, Cat6, and Cat7 Cables**

Category	Type	Spectral B/W	Length	LAN Applications	Notes
Cat3	UTP	16 MHz	100m	10Base-T, 4Mbps	Now mainly for telephone cables.
Cat4	UTP	20MHz	100m	16Mbps	Rarely seen.
Cat5	UTP	100MHz	100m	100Base-Tx, ATM, CDDI	Common for current LANs.
Cat5e	UTP	100MHz	100m	1000Base-T	Common for current LANs.
Cat6	UTP	250MHz	100m		Emerging.
Cat7	ScTP	600MHz	100m		



## Electrical Terminology Overview

### 8-Wire (Discontinued)

The wiring configuration of the electrical 8-wire system is four conductors (12-gauge), two neutrals (10-gauge) and two grounds (12-gauge). This system provides four 20 amp, 125 volt capacity circuits. All receptacles are rated at 15 amp, 125 volt capacity.

### 10-Wire

#### 6-2-2:

(6) hot wires, (2) shared oversized neutral wires, (2) ground wires {(1) isolated ground, and (1) building ground}.

The 6-2-2 system allows more workstations to feed from one power supply point. There are (3) convenience circuits and (3) isolated ground circuits available (sometimes referred to as a 3 + 3 configuration).

#### 4-4-2:

(4) hot wires, (4) independent neutral wires, (2) ground wires {(1) isolated ground, and (1) building ground}.

The 4-4-2 system provides the "independent neutrals" that some customers insist they must have.

### Amperage, Ampere, Amp

The volume (or quantity) of electrical current flowing through a circuit. The current is the voltage of the circuit divided by resistance (ohms) in the circuit.

### Ballast

The device that provides the current for fluorescent lights, and regulates the level (amps) of electrical current and voltage flowing through the fluorescent tube. Ballasts may be magnetic or electronic, with electronic being slightly more energy efficient. Ballasts have become quite small, allowing the creation of compact fluorescent bulbs that can be used in place of incandescent bulbs.

### Bezel

A plastic or metal device that frames the opening used for receptacle attachment.

### Circuit

A complete electrical path. The portion of an electrical run between the breaker or fuse and the devices it powers. Circuits can serve a single device or several and are a complete path for electrical current flowing from the building power source to the equipment being powered and back to the power source.

Circuits are rated according to the number of amps they can accommodate. The total number of amps required by all of the equipment in a furniture installation will dictate the number of circuits required.

### Circuit Breaker

A safety device designed to automatically stop the flow of electricity whenever a circuit becomes overloaded (i.e. exceeds the number of amps that the wiring can accommodate). Branch circuits usually have 20 amp breakers.

The maximum continuous load on a circuit breaker is permitted to be 80% of the rating (16 amps on a 20 amp breaker), which prevents unnecessary power interruptions caused by operation too close to 100% capacity.

### Coaxial Cable

A cable holding a pair of conductors configured so that one completely wraps around and electrically shields the other. Typically 1/4" in diameter.

### Common Ground

An electrical circuit that uses a variety of conductors for a ground path. Ground conductors include wire, conduit, the metal of a building, or water pipes. Because so much of a buildings structure is grounded this way, a common ground is often electrically 'noisy'. Therefore, an isolated ground is more suitable for computers, printers or sensitive equipment.

### Communication Pole

A carrier that transports data cables from the building to work areas.

### Conductor

Any material that can be used to carry electrical power, usually copper wire. See hot conductor, ground conductor, neutral conductor.

**Electrical  
Terminology  
Overview (cont.)**

**Conduit**

Metal or non-metallic tubing, available in either rigid or flexible varieties, used to route and protect electrical wires and communication cables.

**CSA**

Canadian Standards Association. The Canadian equivalent of the National Electric Code (NEC).

**C-UL**

The UL mark for Canada. When on a product it means that samples of the product have been evaluated to Canadian standards and codes by Underwriters Laboratories, Inc. (UL).

**Current**

The rate of electricity flow.

**Daisy Chain**

When conductors run from one device to the next. Saves wire, but if one device fails, all downstream devices are affected. The NEC allows 19 amps per circuit.

**Dedicated Circuit**

A circuit with three conductors, consisting of hot, a unique neutral, and unique ground. This type of circuit greatly reduces 'noise' from other circuits, which can cause problems with sensitive equipment. This is recommended for use with printers and other heavily powered pieces of equipment.

**Device**

The items installed in boxes that help control and distribute current, such as switches, receptacles, timers, thermostats, and dimmers.

**Duplex Receptacle**

A receptacle with two "plug-in" openings which accept two 120 volt three-prong grounded plugs.

**Electro-Magnetic Interference (EMI)**

Interference in telephone or computer lines caused by the flow of current in adjacent electrical conductors. Drives specifications requiring physical separation of power and data.

**Flexible Metal Conduit**

An enclosed channel designed expressly for holding tightly wound wires or cables. Flexible metal conduit is typically required for base infeeds.

**Gauge**

The measure of the size of a wire. The smaller the number, the thicker the wire and the higher its current-carrying capacity.

**Ground Conductor**

The conductor of a circuit that provides safety from fire and electrical shock in cases of short circuits and other electrical problems. The conductor is physically attached and is used to conduct stray electrical current safely back to earth.

**Ground-fault Circuit Interrupter (GFCI)**

A device designed to interrupt the flow of power when a minuscule imbalance is detected between the flow and return of current.

**Harmonics**

When current drawn by the load is at a higher frequency than 60 cycles. Personal computers tend to draw current at 180 cycles.

**Harness**

A device designed to allow connection of receptacles to power cables. These are typically rigid in workstation planning. At either end of the harness an infeed or a jumper may be attached to allow power to pass to another harness.

**Electrical  
Terminology  
Overview (cont.)**

**Hot Conductor**

The conductor that carries current from the power source to the equipment. For a complete circuit, the hot conductor requires a neutral conductor to carry the current back to the power source. Hot conductors usually have black or red insulation.

**Independent Neutral Conductor**

A neutral conductor which is used for only one circuit.

**Infeed**

An electrical component that allows for the connection of power from the building to the individual workstation harnesses and receptacles.

Base power infeed—brings electricity in at the base, or floor of the station, from either the wall or the floor.

Top power infeed—brings electricity in at the top cap, from the ceiling, through the use of a ceiling power pole.

**Insulation**

A material that is a poor conductor of current and therefore used to shield wires, cables, and connectors.

**Isolated Circuit**

A complete circuit consisting of 1) a hot wire, 2) an independent neutral, and 3) an isolated ground. An isolated circuit is electrically separated from other circuits. KI features one isolated circuit on its 8-wire system and may have no or two isolated circuits on its 10-wire power.

**Isolated Ground**

A circuit which has its own unique ground wire. KI features one isolated ground on its 8-wire power and two isolated grounds on its 10-wire power.

**Isolated Receptacle**

A receptacle that uses a dedicated (non-shared) circuit.

**Jumper**

A cable used to pass power from one receptacle-carrying harness to another; does not allow for receptacle attachment to itself.

**Junction Box**

A box containing splices in cables. Has a removable cover that must be accessible (cannot be buried in ceilings and walls). Also called a J-box.

**Knockout (K.O.)**

A partially pre-punched opening in workstation trim or a junction box that is removed to allow the entry of cable.

**Liquid-tight Flexible Conduit**

A raceway of circular cross section having an outer liquid tight (not allowing liquids to enter), nonmetallic, sunlight-resistant jacket over an inner flexible core with associated couplings, connectors and fittings. Approved for the installation of electric conductors. Often required for base infeeds.

**Live**

Hot. See Hot Conductor.

**Maximum Continuous Load**

The maximum electrical current in a circuit expected to be in constant use for three hours or more. For safety considerations, a continuous load must not exceed 80% of the maximum electrical rating. Maximum continuous load for 20 amp circuits is 16 amps. This is important when planning areas such as computer labs and training areas.

**NEC**

National Electrical Code® A set of minimum standards and regulations that governs planning, construction, and installation of electrical conductors and equipment. The NEC is the basis for all electrical codes used in the Legiond States.

**Electrical  
Terminology  
Overview (cont.)**

A governmental body having legal jurisdiction over an installation site could apply NEC regulations alone, or it could apply more restrictive mandatory codes (e.g. local codes).

**NFPA**

National Fire Protection Association. International non-profit organization committed to promoting the science of fire protection and improving fire protection methods. Battery March Park, Quincy, MA 02169.

**Neutral Conductor**

Commonly, the return conductor in a circuit. It usually has white insulation. More properly called the grounded conductor because it returns current to ground at the service panel. Note that this is different from the green-sheathed or bare copper grounding conductor that does not carry current except in case of equipment fault. A neutral conductor is always used with a hot conductor to complete a circuit.

**Ohm**

The measure of electrical resistance.

**Open Circuit**

A circuit in which the flow of current is interrupted due to an open breaker or fuse. May be intentional or unintentional (as caused by a short).

**Outlet**

Receptacle.

**Overload**

To run equipment or wire in excess of its normal full-load rating.

**Pigtail**

A short length of wire attached to an existing wire or wires.

**Polarized**

A system in which the slots/blades for the hot leads are narrower than those for the neutral leads.

**Power Pass Through**

A jumper cable used to pass power from a first panel to third panel without powering the panel in the middle.

**Raceway**

A plastic or metal channel used to conduct wires or cables from one point to another.

**Receptacle Height**

Base – located at the base, or floor, of the workstation.

Worksurface – located just above the worksurface in a workstation, at approximately 32" from base.

ADA – located at 18" from base.

Stand Up Height – located at 44" from base.

**Shared Neutral Conductor**

A circuit design in which one of two conditions exist: all of the hot conductors share a neutral conductor, or separate neutral conductors exist for some, but not all, of the hot conductors.

**Electrical  
Terminology  
Overview (cont.)**

**Short Circuit**

An accidental connection between two conductors or between a conductor and ground or some other unintended surface. A short circuit creates a spark or arc that often damages one or both of the circuit components and causes the circuit breaker to trip.

**Simplex Receptacle**

A receptacle with one plug opening which will accept one 120 volt three-prong grounded plug. See duplex receptacle.

**Surge Protection**

Protection against a fluctuation of the circuit voltage above a normal level over a period of time.

**UL Underwriters' Laboratories**

This is a nonprofit organization that reviews the safety of products, materials, equipment, construction and installation methods, to assure their compliance with the NEC. 333 Pflugsten Road, North Brook, IN 60062.

**Volt**

The measure of electrical pressure, or the force that moves an electrical current. KI's 8- and 10- wire systems use 120 volts as standard.

**Watt, Wattage**

The amount of power used by an electrical device. A function of volts and amperes (amps x volts = watts).

**Whip**

The bundle of wires that gets attached through the use of an infeed.

### 10-Wire Electrical Diagram

6-2-2		
Receptacles available	Wires to be used	Gauge of wire
Circuit 1	Black White/Black Letters Green or Bare	12 10 12
Circuit 2	Red White/Black Letters Green or Bare	12 10 12
Circuit 3	Blue White/Black Letters Green or Bare	12 10 12
Circuit 4I	Pink White/Purple Letters Green/Yellow Stripe or Gray	12 10 12
Circuit 5I	Tan White/Red Letters Green/Yellow Stripe or Gray	12 10 12
Circuit 6I	Orange White/Red Letters Green/Yellow Stripe or Gray	12 10 12

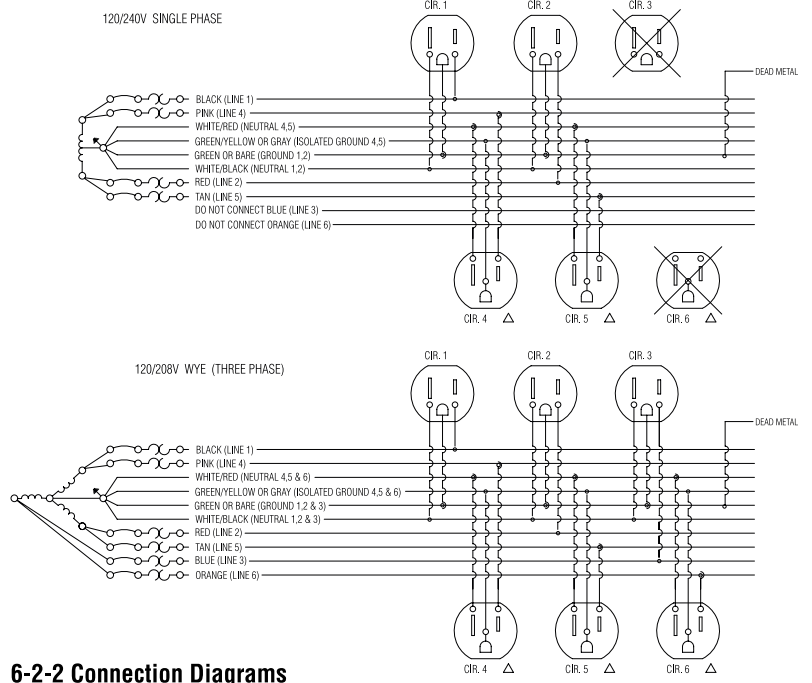

6-2-2 Connection Diagrams

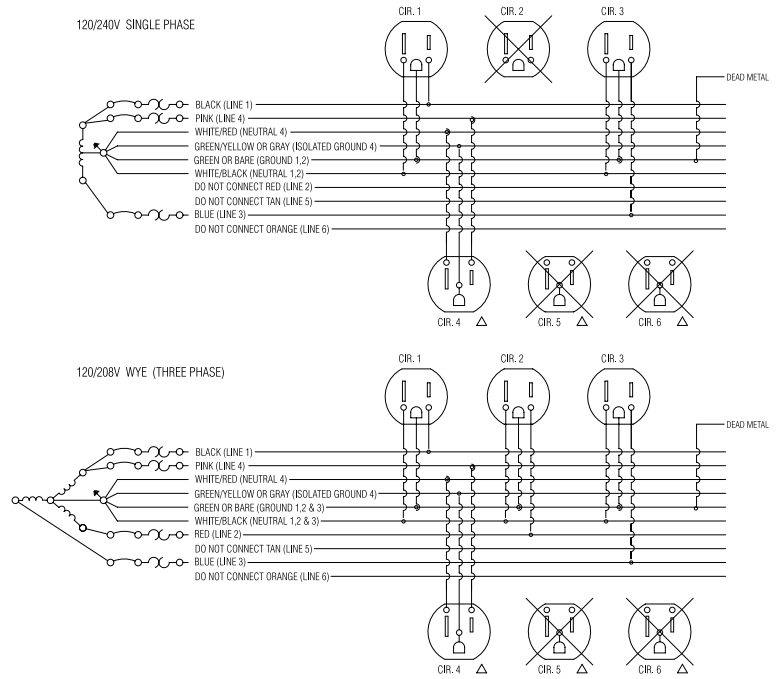

6-2-2 Connection Diagrams To An 8-Wire Building

**Worksurfaces**

Legion offers a variety of worksurface shapes especially designed to complement flexible workstation planning. All are available in a wide range of sizes. Edges and grommet locations may be specified.

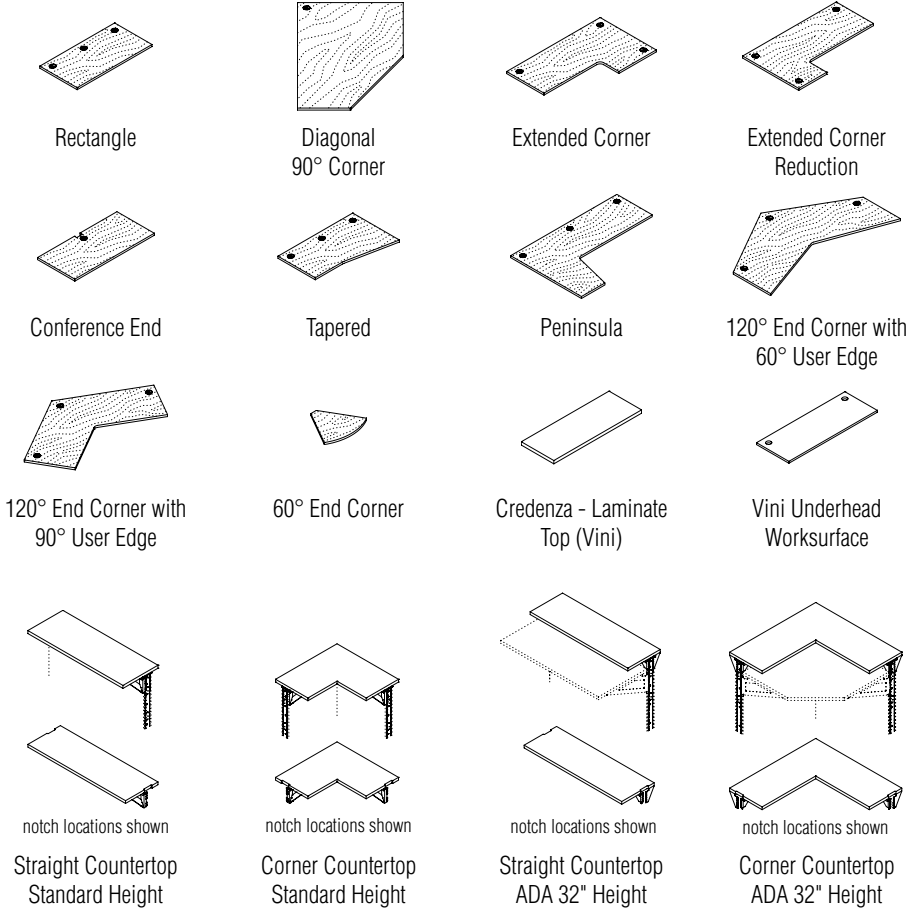

**Worksurfaces (cont.)**

**Worksurface Guidelines**

Unless specified (i.e. Transaction Counter Tops), all worksurface brackets and supports must be specified separately. Two brackets are required for 24" thru 72" and three for longer than 72". Surfaces that are not symmetrical can be ordered in opposing orientations. However, right or left is not indicated in the model number. The orientation or "hand" of the surface is specified by identifying the length of each surface edge from left to right (sides A, B, C, D) and is configured in the model string name (see Legion Price List for examples). 60" and longer surfaces contain a pre-installed, steel stiffener that is "flush" with the bottom of the worksurface. 74P and Knife edge options are available with some restrictions. Knife edge is typically restricted to the edge facing the occupant.

Unless specified, please reference the Legion Price List for size details. Widths of all surfaces accommodate all Legion Panel widths. In addition, depths of all surfaces accommodate Legion Panel widths as well as most storage components. Example: 22" deep surfaces accommodates Vini Tower depth.

For bracket & support rules see Worksurface Support Guideline section.

**Grommet Location and Symbols:**

N= No Grommet

L = Left

C = Center

R = Right

LR = Left/Right

LC = Left/Center

CR = Center/Right

LCR = Left/Center/Right

**Rectangular**

Model: LGWR

Grommet location options as shown: Left = L, Center = C, Right = R. For grommet combinations see "Grommet Location and Symbols" list above.

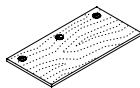

**Diagonal 90° Corner**

Model Number: LGWDC

Diagonal 90° Corner Worksurface is symmetrical. Grommet location is limited to back corner (C= center). Depth is specified by adjacent worksurface depth. Grain direction is diagonal.

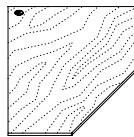

**Extended Corner**

Model Number: LGWEC

Extended Corner Worksurface is used when depths of adjacent surface edges match. Depth is specified by adjacent worksurface depth. Grommet location options as shown (Left = L, Center = C, Right = R). For grommet combinations see "Grommet Location and Symbols" list above.

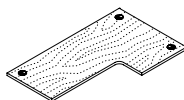



**Worksurfaces (cont.)**

**Extended Corner Reduction**

Model Number: LGWEC

Extended Corner Reduction Worksurface is used when depth of adjacent surface edges do not match. Depth is specified by adjacent worksurface depth. Grommet location options as shown (Left = L, Center = C, Right = R). For grommet combinations see "Grommet Location and Symbols" list on page 60.

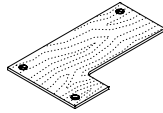

**Conference End**

Model Number: LGWCE

Conference End Worksurface is designed to fit at the end of a panel run (EOR) that has surfaces on either side of the panel. Grommet location is limited to the center (C = Center). The width is extended by 3.5" to accommodate for the panel thickness. Example: 51" nominal width for connecting two 24" surfaces and 63" nominal width for connecting two 30" surfaces.

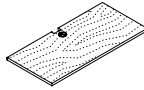

**Tapered**

Model Number: LGWT

Tapered Worksurface allows user to face away from the workstation corner. Grommet location options as shown (Left = L, Center = C, Right = R). For grommet combinations see "Grommet Location and Symbols" list on page 60.

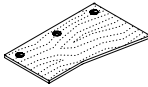

**Peninsula**

Model Number: LGWP

Peninsula Worksurface allows user to face away from the workstation corner. Grommet location options as shown (Left = L, Center = C, Right = R). For grommet combinations see "Grommet Location and Symbols" list on page 60.

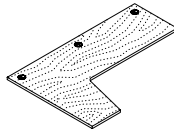

**120° End Corner/60° User Edge**

Model Number: LGW120

120° End Corner with 60° User Edge Worksurface is designed for use when ends of surface mate to 120° panels. Grommet location options as shown (Left = L, Center = C, Right = R). For grommet combinations see "Grommet Location and Symbols" list on page 60.

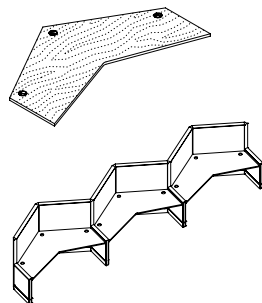

**Worksurfaces (cont.)**

**120° End Corner/90° User Edge**

Model Number: LGWIC120

120° End Corner Worksurface is designed for use when ends mate to 60° end corners and create a chain of 120° surfaces along a run of 120° panels. Other configurations apply. Grommet location options as shown (Left = L, Center = C, Right = R). For grommet combinations see “Grommet Location and Symbols” list on page 60.

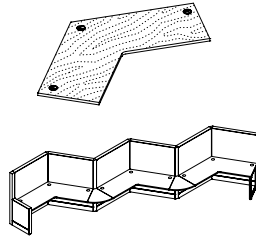

**60° End Corner**

Model Number: LGW120

Size: 22" x 22" and 24" x 24"

60° End Corner Worksurface is designed for use to connect 120° end corners with 90° user edge to create a chain of 120° surfaces. Attaches to mating surface with splice plates (see Bracket Planning Section). No grommet option.

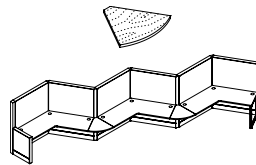

**Vini™ Underhead Worksurface**

Model Number: VHS

Width: Accommodates a variety of Legion panel widths.

Depth: 15"

Vini Underhead Worksurface is designed for use with Vini Underhead Storage Cabinet. Underhead Storage Cabinet always aligns with the back edge of the Underhead Worksurface. Construction is the same as standard Legion Worksurfaces. Underhead worksurfaces are pre-drilled to match underhead storage cabinet mounting holes.

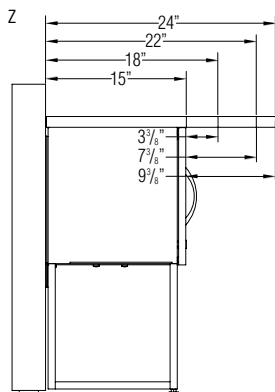
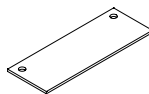

**Standard Edge**

- Specify by width of underhead storage cabinet.
- Left and/or Right grommets are offered (Left = L, Right = R). Underhead storage cabinet includes holes for cable passage.
- Center grommet not allowed.
- 15" deep underhead worksurface is flush to front edge of underhead.
- Underhead worksurface sizes over 15" deep, extend beyond the front of the underhead storage cabinet.
- 30" depth not allowed.

## Transaction Countertops

### Transaction Countertops

Two types of Transaction Countertops are available: Standard and 32" Height. 32" high tops are designed to comply with ADA requirements. Transaction Countertops are shipped with all necessary brackets and hardware. 74P Edge is available on the outside and inside edge with some restrictions for 32" high tops. Design style brackets are included with standard height tops. Standard height tops do not require any brackets on the outside edge of the work station providing a clean look. 32" high ADA tops require brackets on both inside & outside of the workstation. Transaction Countertops attach to Legion panels without disassembly of any panel components. 84" wide straight tops include an extra bracket. Brackets include a steel locking clip to prevent dislodgment.

#### Straight Transaction Countertop/Standard Height

Model Number: UWTR

Width: Accommodates all Legion panel widths

Depth: 16"

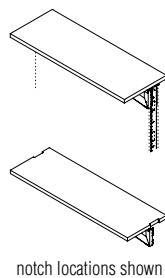

- Includes cantilever support brackets and locking clips to prevent dislodgement.
- Used with all Legion panel heights.
- Can be used with all Legion panel configurations except panels with aluminum frame stacking sections. These sections do not have bracket slots and cannot support hang on component loading.
- If countertop is installed adjacent to an in-line height change, a notch must be specified on the left, right or both sides of the worksurface.
- Accepts task lights.
- Transaction countertop adds 1 1/4" to height of panel.

#### Straight Transaction Countertop/32" Height

Model Number: UWTR32

32" Straight Transaction Countertops are designed for use with 32" high Legion panels. Resulting height of the top surface is no higher than 34" which complies with ADA guideline 4.32.1. Transaction Countertop extends no more than 4" into the aisle to comply with ADA guideline 4.4.1.

Width: Accommodates all Legion Panel widths.

Depth: 16"

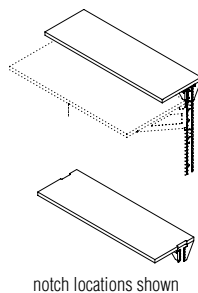

- Includes cantilever support brackets and locking clips to prevent dislodgement.
- Designed for use with 32" high Legion panels.
- Can be used with all Legion panel configurations except panels with aluminum frame stacking sections. These sections do not have bracket slots and cannot support hang on component loading.
- Knife edge not allowed on outside edge of work station due to outside bracket on the 32" height.
- If transaction countertop is installed adjacent to an in-line height change, a notch must be specified on the left, right or both sides of the worksurface.
- Accepts task lights.
- Transaction countertop adds 1 1/4" to height of panel.

**Transaction  
 Countertops (cont.)**

**Corner Transaction Countertop/Standard Height**

Model Number: UWTRC

Standard Height Corner Transaction Countertops are constructed with two-surfaces that are mitered at a 90° angle. Miter connecting hardware included with model.

Width: 24", 30", 36"  
 Depth: 16"

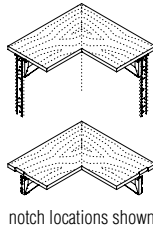

- Includes cantilever support brackets and locking clips to prevent dislodgement.
- Can be used with all Legion panel heights.
- Can be used with all Legion panel configurations except panels with aluminum frame stacking sections. These sections do not have bracket slots and cannot support hang on component loading.
- If transaction countertop is installed adjacent to an in-line height change, a notch must be specified on the left, right or both sides of the worksurface.
- Width is symmetrical and specified by the attached panel width.
- Accepts task lights.
- Transaction countertop adds 1 1/4" to height of panel.
- Grain direction is perpendicular at miter connection.

**Transaction Corner Countertop/32" Height**

Model Number: UWTRC32

32" Transaction Corner Countertop is designed for use with 32" high Legion panels. Resulting top height is no higher than 34" which complies with ADA guideline 4.32.1. Transaction Countertop extends no more than 4" into the aisle to comply with ADA guideline 4.4.1. The top is construction with two surfaces that are mitered at a 90° angle. Miter connecting hardware included with model.

Width: 24", 30", 36"  
 Depth: 16"

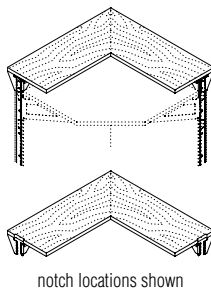

- Includes cantilever support brackets and locking clips to prevent dislodgement.
- Designed for use with 32" high Legion panels.
- Can be used with all Legion panel configurations except panels with aluminum frame stacking sections. These sections do not have bracket slots and cannot support hang on component loading.
- If countertop is installed adjacent to an in-line height change, a notch must be specified on the left, right or both sides of the worksurface.
- Width is symmetrical and specified by the attached panel width.
- Accepts task lights.
- Transaction countertop adds 1 1/4" to height of panel.
- Grain direction is perpendicular at miter connection.

**Vini Credenza - Laminate Top**

Model Number: UWCT

Vini Credenza - Laminate Tops are construction with high pressure laminate and particle board core. The top ships with several pieces of double back foam tape; used to attach the top to the credenza in the field. Back to back credenzas should be specified with a single Credenza Top of appropriate depth. No grommet options.

Width: 15 1/8", 30 1/8"  
 Depth: 36 1/8", 42 1/8"

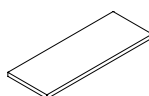

- Ships with double back foam tape for attaching to credenza.
- 74P is the only edge option.

**Worksurface Supports**

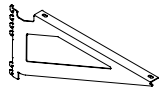

Standard Cantilever Bracket (left shown)

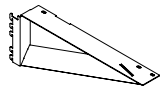

Design Cantilever Bracket (left shown)



Worksurface Edge Support with Lock (left shown)

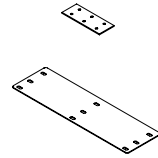

Splice Plates

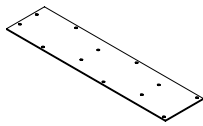

Add-On Peninsula Attachment Plate

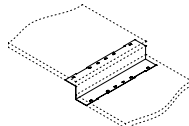

In-Line Height Change

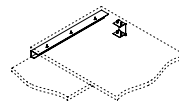

Corner Height Change



Post Leg 29" Height

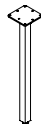

Post Leg 26" Height

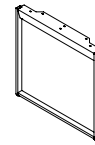

Support Leg (non-handed) Non-Panel Mounted Open, 29" Height

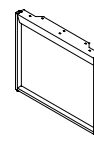

Support Leg (non-handed) Non-Panel Mounted Open, 26" Height

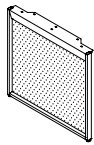

Support Leg (non-handed) Non-Panel Mounted Insert, 29" Height

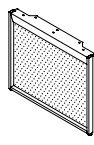

Support Leg (non-handed) Non-Panel Mounted Insert, 26" Height

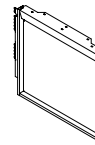

Support Leg (left shown) Panel Mounted Open, 29" Height

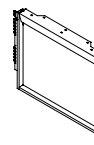

Support Leg (left shown) Panel Mounted Open, 26" Height

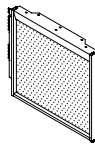

Support Leg (left shown) Panel Mounted Insert, 29" Height

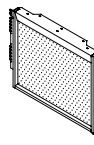

Support Leg (left shown) Panel Mounted Insert, 26" Height

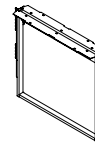

Support Leg Center (non-handed) Panel Mounted Open, 29" Height

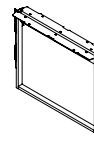

Support Leg Center (non-handed) Panel Mounted Open, 26" Height

**WORKSURFACE SUPPORTS**

Legion offers a wide variety of worksurface shapes and support brackets, which are specified independently for optimal flexibility. To ensure that worksurfaces are properly supported, refer to the worksurface layouts for bracket planning rules for all bracket styles.

**Tips:**

- Any edge of a worksurface that is adjacent to a panel must have some form of bracket specified for each end of the panel to which it is anchored.
- All worksurfaces **MUST** be anchored to adjacent worksurfaces with splice plates.
- Worksurfaces may span multiple panels; however, worksurfaces longer than 72" must use 3 brackets along their length.

**Cantilever Brackets**

**Standard Cantilever Bracket**

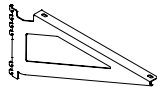

- Used for general support of all 22", 24" and 30" depth worksurfaces regardless of edge style.
- Specify right or left.

**Design Cantilever Bracket**

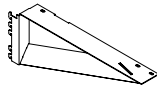

- Used for general support of all 18" deep worksurfaces regardless of edge style.
- Can be used with peninsula supports for worksurface only loaded panel returns.
- Specify right or left.

**Worksurface Edge Support with Lock**



- Used to tie the edge of a 24" or 30" deep worksurface into return panels.
- Specify right or left.

**Splice and Attachment Plates**

Splice Plates are used to tie adjacent worksurfaces together to improve surface alignment and rigidity. Splice Plates are used in conjunction with cantilever brackets. Attachment Plates are used to mate two surfaces at a perpendicular connection without the use of cantilever brackets.

**Splice Plate**



- Used to tie all 18", 24" and 30" worksurfaces to adjacent worksurfaces.

**Splice Plate, 22" Worksurface**

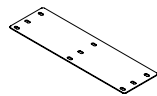

- Used to tie 22" worksurfaces to adjacent worksurfaces.

**Add On Peninsula Attachment Plate**

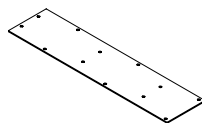

- Used to anchor approved worksurface sizes perpendicular to another surface.
- Mating worksurface must be anchored to a Legion panel per approved worksurface attachment.
- Opposite end of peninsula worksurface must have an approved peninsula worksurface support.
- For use with 74P edge style only; including mating surface.
- Not for use with surfaces longer than 72".
- Attachment end must be 22", 24", 30" widths only.
- Tapered worksurfaces can be used.

**Height Change Brackets**

Used when adapting from 26" high worksurface planning to 29" high worksurface planning. Two styles are available.

**In-Line Height Change**

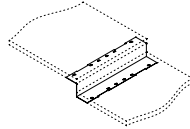

- Used when changing worksurface heights In-Line.
- Replaces splice plates and requires cantilever brackets beneath both upper and lower worksurfaces.

**Corner Height Change**

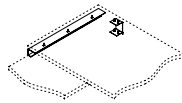

- Used when adapting worksurface heights at a corner.
- Requires approved supports for lower worksurface and only lower worksurface may function as a return panel.
- Depth specified by upper worksurface depth.
- **Note:** If lower worksurface is functioning as return, panel may be worksurface loaded only!

**Support Legs**

**Post Legs**

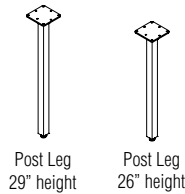

- Used for Peninsula or conference end support.
- Can be ordered in 29" and 26" heights.
- **Cannot be used to configure stand-alone tables.**

**Support Leg, Non-Panel Mounted**

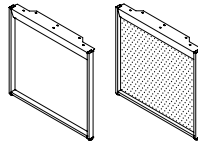

- Non-Panel mounted (no brackets).
- Used at end of perpendicular worksurfaces that function as panel returns.
- Non-handed.
- Specify by depth of supported worksurfaces.
- Can be ordered in 29" and 26" heights.
- Can be ordered open or with insert.
- **Cannot be used to configure stand-alone tables.**

**Support Leg, Panel Mounted (left shown)**

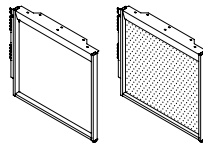

- Panel mounted (brackets).
- Used in place of return panels for supporting worksurfaces and panel runs.
- Specify right or left.
- Specify by length of worksurface functioning as a return.
- 18" depth may be used to function as a return on combination loaded panels with peninsula worksurfaces.
- Can be ordered in 29" and 26" heights.
- Can be ordered open or with insert.
- **Cannot be used to configure stand-alone tables.**

**Support Leg Center, Panel Mounted**

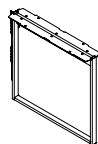

- Panel mounted (brackets).
- Used on long runs in place of returns, at intervals indicated as maximum length configuration.
- Replace both cantilever brackets and splice plates for adjacent worksurfaces.
- Non-handed. Leg is centered between joining worksurfaces and connects to left panel slotting but also covers adjacent right slotting.
- Specify by depth of worksurface.
- Can be ordered in 29" and 26" heights.
- Can only be ordered open.
- **Cannot be used to configure stand-alone tables.**

**WORKSURFACE  
 BRACKET LAYOUTS  
 INTRODUCTION**

The following layouts should be used as a guide for bracket use on all worksurface shapes.

The purpose of these graphics is to show the different ways that worksurfaces can interact with panels and other adjacent worksurfaces. Each end of a worksurface must be supported in some way and the required brackets will be specified by matching the configuration of each end of your worksurface up with a layout.

**Note:**

- View shown from above the workstation down, brackets shown non-hidden for full visibility.
- For all graphics, bracket position and shape are approximate.
- Some parts not shown to scale.
- In-line worksurface connections shown for reference, worksurface support must be specified at all worksurface ends.
- Specify one of each type of bracket for each symbol shown on a configuration.
- Match components to models using the symbols shown.

**In-Line Worksurfaces**

Symbol	Bracket
C-R	Standard cantilever (right hand)
C-L	Standard cantilever (left hand)
D-R	Design cantilever 12" (right hand)
D-L	Design cantilever 12" (left hand)
S-S	Splice plate
SL-C	Support leg center, panel mounted
I-COH	In-Line change of height
22-S	22" splice plate

**Basic In-Line Connection**

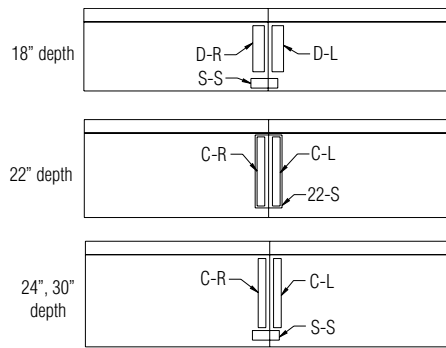

- Worksurface may be any shape provided connecting ends match depths shown at left.
- Worksurface depths must be the same on both sides of connection.
- Worksurface heights must be equal.
- Splice plates required for all intersections.

**Center Panel-Supporting Worksurface Support Leg (panel supporting)**

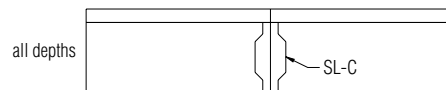

- Worksurface may be any shape provided connecting ends match depths shown at left.
- Worksurface depths must be the same on both sides of the connection.
- Worksurface heights must be equal.
- Panel runs on both sides of center support can be maximum lengths allowed.

**In-Line Change of Height 26" and 29"**

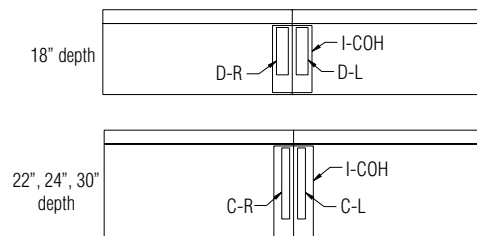

- Worksurface may be any shape provided connecting ends match depths shown at left.
- Worksurface depths must be the same on both sides of the connection.
- Bracket is non-handed, left or right worksurfaces can be taller.
- Planning rules are unaffected by in-line height change, provided return styles are approved for main run loading conditions.



**Corner Intersecting Worksurfaces**

Symbol	Bracket
C-R	Standard cantilever (right hand)
C-L	Standard cantilever (left hand)
D-R	Design cantilever 12" (right hand)
D-L	Design cantilever 12" (left hand)
22-S	22" splice plate
ES-L	Edge support (left)
ES-R	Edge support (right)
S-S	Splice plate
WS	Worksurface

**Corner Intersection with Rectilinear Worksurfaces**

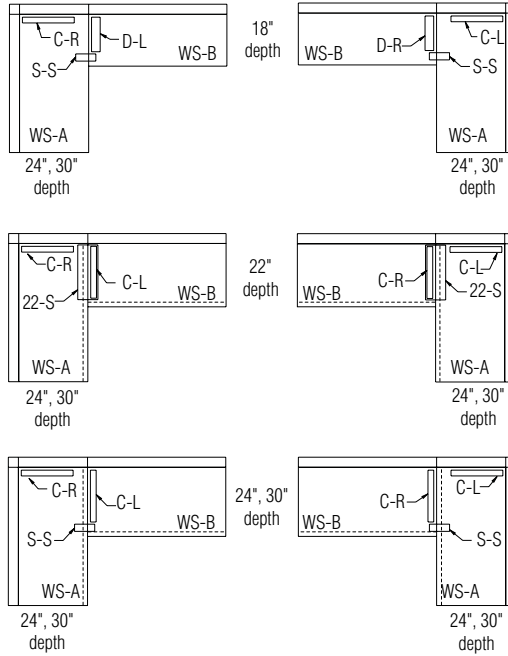

- Corner worksurface WS-A depth must match panel width (24" or 30" only); maximum length is 72".
- Worksurface heights must be equal.
- Splice plate REQUIRED for these intersections.
- Peninsula worksurfaces can be used in the WS-B positions.

**Corner Intersections with Tapered Worksurfaces**

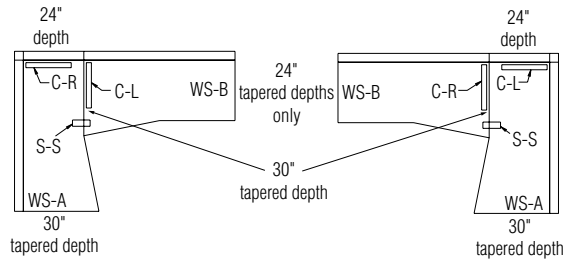

- Worksurface must be of 24"/30" depth tapers.
- Corner worksurface WS-A depth must match panel width (24" only); maximum length is 72".
- If tapered surfaces are of same width, the angle between tapered sections will be 90°.

**Corner Worksurface Shapes**

Symbol	Bracket
C-R	Standard cantilever (right hand)
C-L	Standard cantilever (left hand)
D-R	Design cantilever 12" (right hand)
D-L	Design cantilever 12" (left hand)
22-S	22" splice plate
C-COH	Corner change of height
ES-L	Edge support (left)
ES-R	Edge support (right)
WS	Worksurface

**Corner Intersecting Change of Height 26" and 30"**

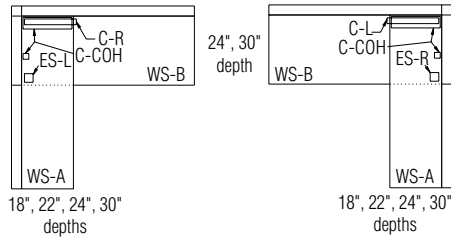

- Rectangular worksurfaces recommended for this application.
- Corner worksurface WS-B depth must match panel width (24" or 30" only); maximum length is 72".
- Standard cantilever bracket used for all depths of worksurface.

**Diagonal Corner**

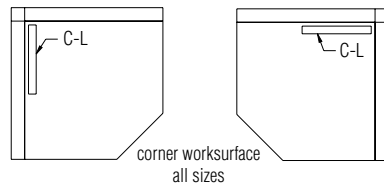

- Specify left hand cantilever for all sizes/orientations.
- Depth is specified by adjacent worksurface depth.

**Extended Corner**

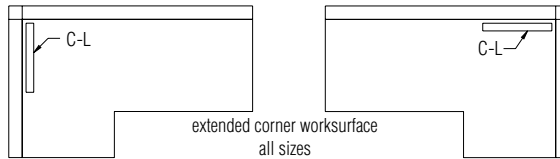

- Specify left cantilever for all sizes/orientations.
- Depth is specified by adjacent worksurface depth.

**Peninsula Worksurface as Corner**

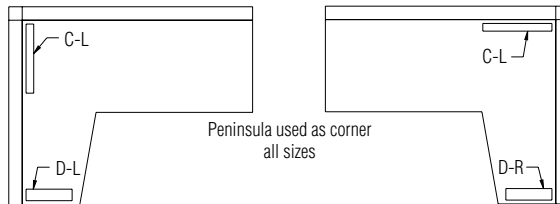

- Specify left hand cantilever for all sizes/orientations.
- Depth is specified by adjacent worksurface depth.

**Corner Worksurface Shapes**

Symbol	Bracket
C-R	Standard cantilever (right hand)
C-L	Standard cantilever (left hand)
22-S	22" splice plate

**120° Corner, 120° Ends**

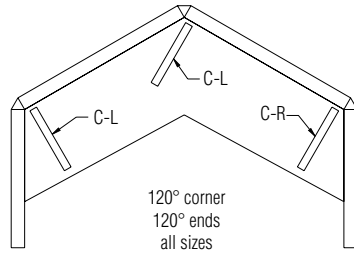

- Return panel may be of any length.
- Same brackets for all sizes/depths.

**120° Corner, 90° Ends**

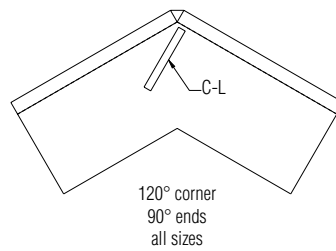

- Specify left hand cantilever for all sizes/orientations.
- Depth is specified by adjacent worksurface depth.

**60° Corner**

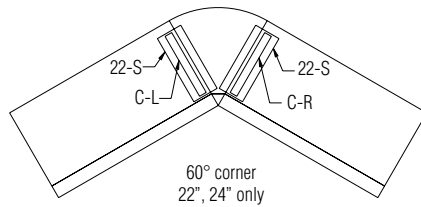

- Attached to 22" and 24" deep worksurfaces only.
- All worksurfaces must be of same depth and height.

**Free End Worksurfaces**

**All Worksurface Shapes**

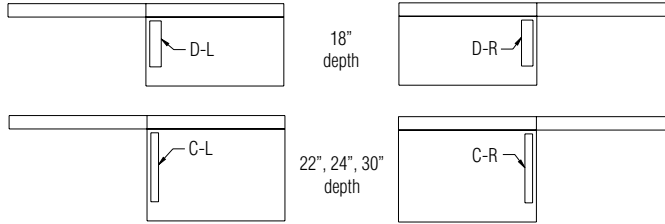

- End of worksurface must be of one of the shown depths.
- Only one end of worksurface may be of free end style with opposite end being an approved worksurface support.

**Add On Worksurfaces**

**Add-On Peninsula Mounting for Rectilinear and Tapered Worksurfaces**

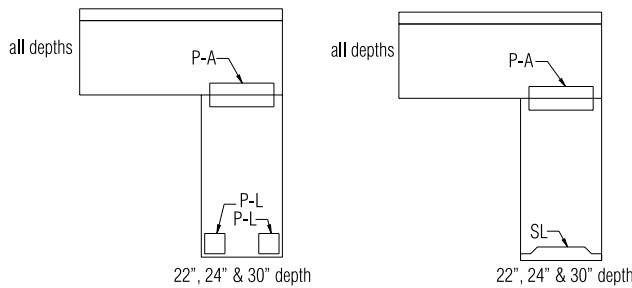

- Maximum worksurface length: 72".
- Only for use with 22", 24" & 30" worksurface depths.
- For 22" and 24" connections use the 24" nominal size peninsula attachment plate (UPENPL24). For 30" connection use the 30" nominal size peninsula attachment plate (UPENPL30).
- Tapered worksurfaces to use the rectangular end for attachment. The 30" tapered end is used as peninsula end.
- Three end support styles are available:
  - a. two post legs
  - b. worksurface support leg (specify depth that matches peninsula end)
  - c. Vini pedestal file (specify "no bracket")

Symbol	Bracket
C-R	Standard cantilever (right hand)
C-L	Standard cantilever (left hand)
D-R	Design cantilever 12" (right hand)
D-L	Design cantilever 12" (left hand)
P-A	Peninsula accessory (24" & 30")
ES-R	Edge support (right)
P-L	Post leg
SL	Support leg, non-panel mounted
V-PED	Vini pedestal

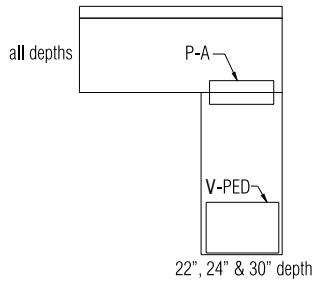

**Rectilinear**

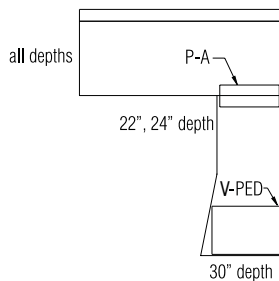
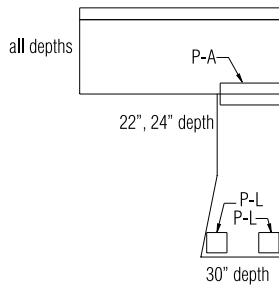

**Tapered**

**Add On Worksurfaces**

**Conference End**

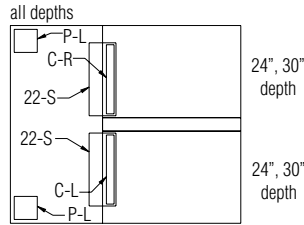

- Worksurface must be rectangular with depths matching those shown at left.
- Non-handed.
- Functions as return for worksurface loading only.

**Panel Return Options**

**Return Panel**

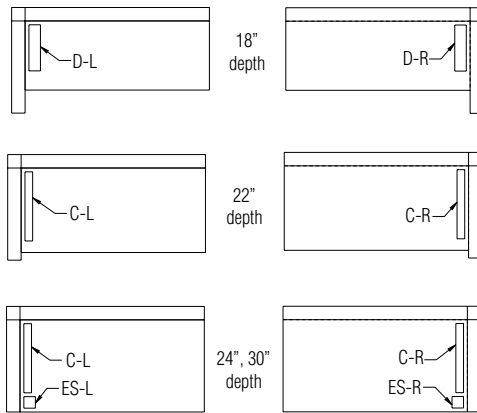

- Worksurfaces may be any shape with depths matching those shown at left.
- 18" & 22" depths do not use edge support, and return panel may be of any length.
- For 24" & 30" depths, it is recommended that the return panel match the depth of the worksurface such that an edge support bracket can be used.
- If a return panel must be longer than worksurface, depth edge support can be omitted.
- It is recommended that any multi-panel returns used 24" or 30" worksurfaces with edge supports. A 24" or 30" panel should be used first, with additional panels added for longer returns.
- **Panels may have combination storage and worksurface loading.**

Symbol	Bracket
C-R	Standard cantilever (right hand)
C-L	Standard cantilever (left hand)
D-R	Design cantilever 12" (right hand)
D-L	Design cantilever 12" (left hand)
ES-L	Edge support (left)
ES-R	Edge support (right)
SL-L	Support leg, panel mounted (left)
SL-R	Support leg, panel mounted (right)
V-PED	Vini pedestal
V-PED-BKT	Vini pedestal attach bracket
P-L	Post leg

**Worksurface Support Leg (Panel Supporting)**

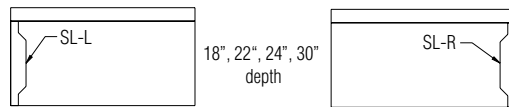

- Worksurface may be any shape, provided end with support leg matches depths shown at left.
- **29" high worksurface applications may incorporate combination storage and worksurface loading.**
- **26" high worksurface applications may incorporate ONLY worksurface loading.**

**Vini Pedestal Support with Accessory Panel Attach Bracket**

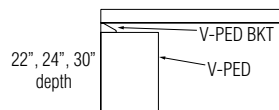

- Worksurfaces may be any shape, provided end with pedestal matches depths shown at left.
- Pedestal must be ordered with accessory panel attach bracket reflecting appropriate worksurface depth.
- 29" mounting height only is available.
- **Panels may have combination storage and worksurface loading.**

**Panel Return Options**

Symbol	Bracket
C-R	Standard cantilever (right hand)
C-L	Standard cantilever (left hand)
D-R	Design cantilever 12" (right hand)
D-L	Design cantilever 12" (left hand)
ES-L	Edge support (left)
ES-R	Edge support (right)
SL	Support leg, non-panel mounted
SL-L	Support leg, panel mounted (left)
SL-R	Support leg, panel mounted (right)
V-PED	Vini pedestal
V-DPED	Vini double pedestal
V-DP-BKT	Vini double pedestal accessory bracket
P-L	Post leg

**Vini Double Pedestals with Accessory Panel Attach Bracket**

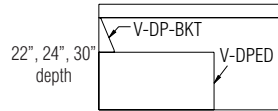

- Worksurfaces may be any shape, provided end with pedestal matches depths shown at left.
- Pedestals may be of any width provided panels and worksurface they are anchored to are of same width or greater
- Accessory panel attach bracket REQUIRED for all worksurface depths.
- **Panels may have combination storage and worksurface loading.**
- **Panels may have combination storage and worksurface loading.**

**Peninsula Worksurface with Design Cantilever**

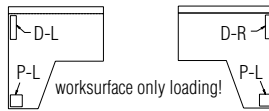

- Peninsula may be of any size.
- Panel may be of any height.
- **Panels may ONLY have worksurface loading.**

**Peninsula Worksurface with Worksurface Support Leg (Panel Supporting)**

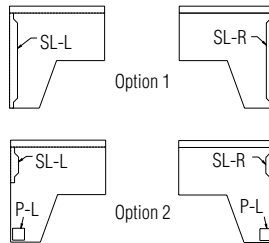

- Option 1 panel support leg depth must match peninsula side of worksurface.
- Option 2 panel support leg depth is 18".
- **Panels may have combination storage and worksurface loading with either option.**

**Panel Return Options**

Symbol	Bracket
C-R	Standard cantilever (right hand)
C-L	Standard cantilever (left hand)
D-R	Design cantilever 12" (right hand)
D-L	Design cantilever 12" (left hand)
ES-L	Edge support (left)
ES-R	Edge support (right)
SL-L	Support leg, panel mounted (left)
SL-R	Support leg, panel mounted (right)
V-PED	Vini pedestal
S-S	Splice plate
P-L	Post leg

**Perpendicular Worksurfaces**

**Note:** Applications shown in the support option box must be specified **in addition to** brackets shown. All other applications will show all brackets requiring specification for the shown configuration.

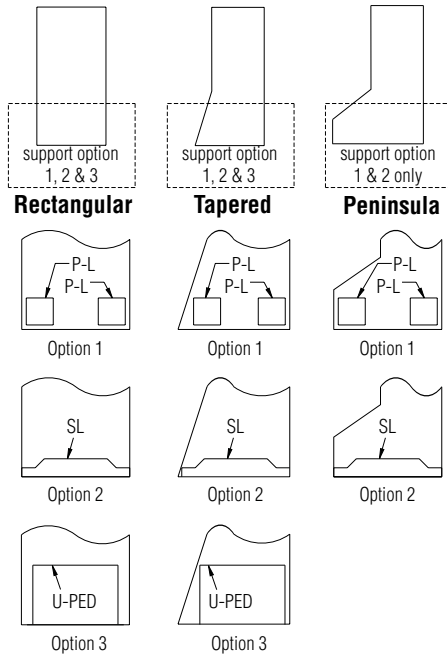

- Support options 1, 2, & 3 can be used on rectangular and tapered worksurfaces of depths 24" & 30" when mounted to a panel. Peninsula worksurfaces can only use support options 1 and 2.

**Rectangular/Tapered/Peninsula Perpendicular Worksurfaces with Design Cantilever**

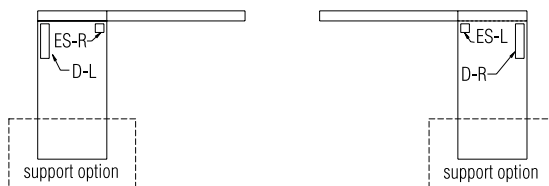

- Applies to rectangular, tapered and peninsula worksurfaces.
- Specify a support option 1, 2 or 3 from the list at the beginning of this section as appropriate.**
- Worksurface depth must match panel width at attaching end (24" & 30" only), maximum length is 72".
- Panel may be of any height.
- Panels may ONLY have worksurface loading.**

**Rectangular/Tapered/Peninsula Perpendicular Worksurfaces with Worksurface Support leg (panel supporting)**

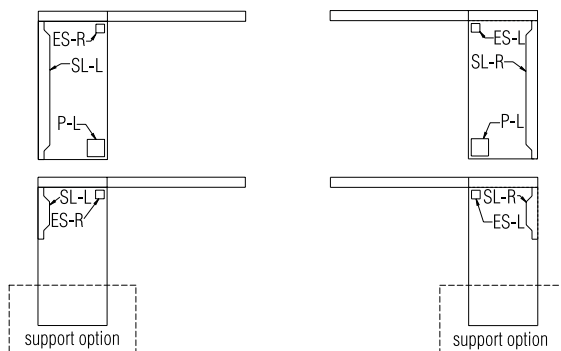

- Applies to rectangular, tapered and peninsula worksurfaces.
- Specify a support option 1, 2 or 3 from the list at the beginning of this section as appropriate.**
- Worksurface depth must match panel width at attaching end (24" & 30" only); maximum length is 72".
- Panel may be of any height.
- Specify worksurface support leg length by worksurface length. 18" is the minimum support leg length.
- Panels may have combination storage and worksurface loading.**

**Panel Return Options**

Symbol	Bracket
C-R	Standard cantilever (right hand)
C-L	Standard cantilever (left hand)
D-R	Design cantilever 12" (right hand)
D-L	Design cantilever 12" (left hand)
ES-L	Edge support (left)
ES-R	Edge support (right)
SL-L	Support leg, panel mounted (left)
SL-R	Support leg, panel mounted (right)
S-S	Splice plate
22-S	22" Splice plate
P-L	Post leg

**Rectangular/Tapered/Peninsula Perpendicular Worksurfaces with Adjacent Worksurfaces and Design Cantilever**

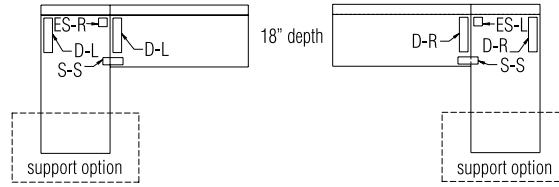

- Applies to rectangular, tapered and peninsula worksurfaces.
- **Specify a support option 1, 2 or 3 from the list at the beginning of this section as appropriate.**
- Worksurface depth must match panel width at attaching end (24" & 30" only); maximum length is 72".
- Panel may be of any height.
- Specify a support option 1, 2 or 3 from the list at the beginning of this section as appropriate.
- **Panels may ONLY have worksurface loading.**

**Rectangular/Tapered/Peninsula Worksurfaces with Adjacent Worksurfaces and Worksurface Support Leg (panel supporting)**

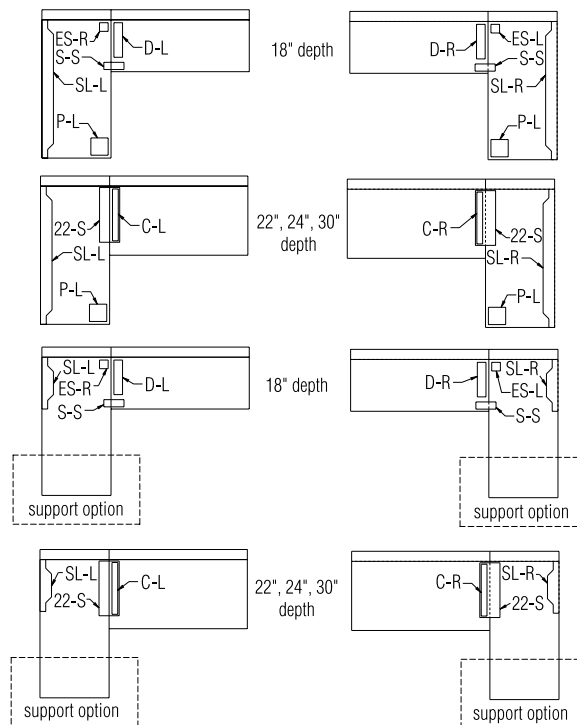

- Applies to rectangular, tapered and peninsula worksurfaces.
- **Specify a support option 1, 2 or 3 from the list at the beginning of this section as appropriate.**
- Worksurface depth must match panel width at attaching end (24" & 30" only); maximum length is 72".
- Panel may be of any height.
- Specify worksurface support leg length by worksurface length. 18" is the minimum support leg length.
- **Panels may have combination storage and worksurface loading.**



**Panel Return Options**

Symbol	Bracket
C-R	Standard cantilever (right hand)
C-L	Standard cantilever (left hand)
D-L	Design cantilever 12" (left hand)
S-S	Splice plate
WS	Worksurface

**Panels with Worksurface/Underhead Storage Loading and Returns Inline Connection**

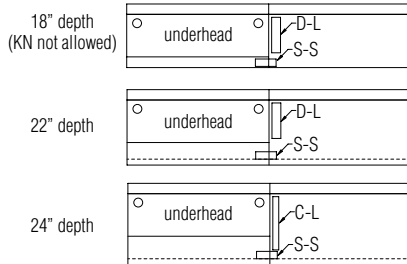

- 22" splice plate (22-S) cannot be used with 22" worksurfaces.
- 12" design cantilever must be used with 18" and 22" worksurfaces are adjacent.

**Panels with Worksurface/Underhead Storage Loading and Returns Corner Intersection**

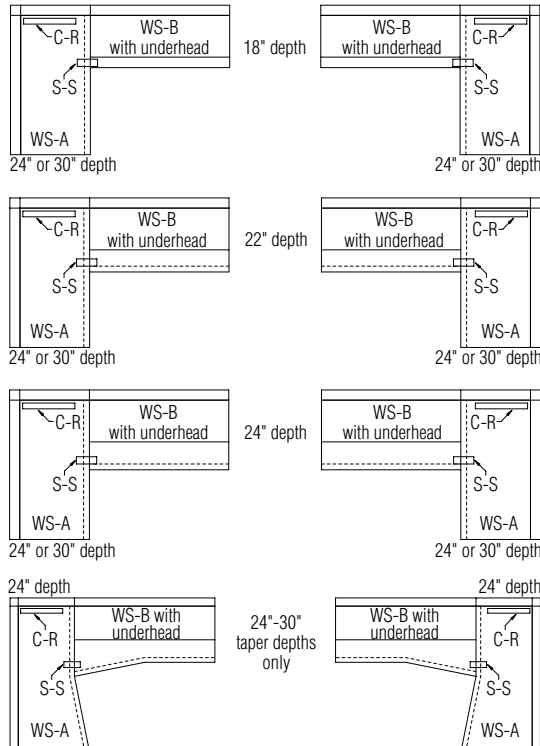

- Corner worksurface WS-A depth must match panel width (24" or 30" only); maximum length is 72".
- Worksurface heights must be equal.
- Splice plate REQUIRED for these intersections.

**Additional Supports for 72" Long Worksurfaces**

Symbol	Bracket
ES-L	Edge support (left)

**72" Long Worksurfaces That Span Split Tiles and Multiple Panels**

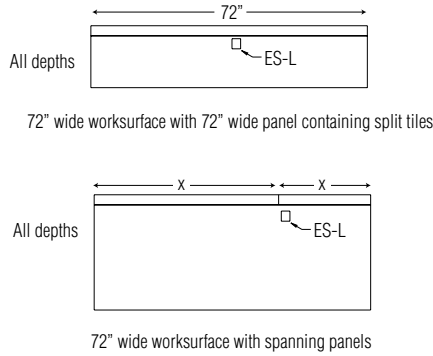

**Note:** Legion offers a unique 72" wide panel that contains two 36" wide tiles (split tiles) and a center steel light block. The light block contains a short series of slots designed for edge bracket installation only.

- One left edge bracket and lock required when 72" worksurface is used with 72" panels that have split tiles.
- One left edge bracket and lock required when 72" worksurface is used with 72" spanning panels.

**Accessory Worksurface Supports**

Symbol	Bracket
C-R	Standard cantilever (right hand)
C-L	Standard cantilever (left hand)
D-R	Design cantilever 12" (right hand)
SL-C	Support leg center, panel mounted
I-COH	In-Line change of height
D-L	Design cantilever 12" (left hand)
S-S	Splice plate
22-S	22" Splice plate

**Worksurfaces with Wall Track (30" wall track only)**

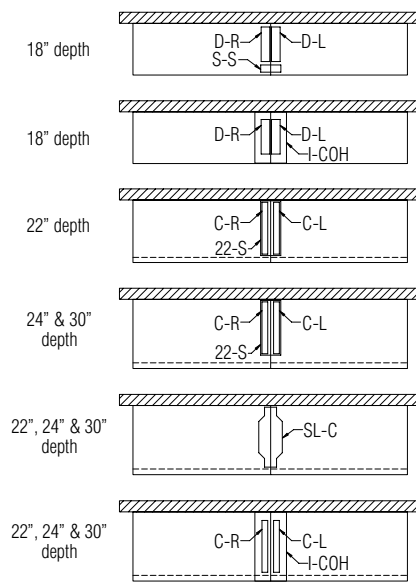

- If a center support leg is desired, select support leg for a worksurface 2" less deep (Example: For a 24" deep worksurface use the 22" center support leg model).
- A center support leg will not work with an 18" deep worksurface.
- Height change brackets can be used as standard. Match the depth of the COH bracket with the depth of the surface. The mounting cantilever must be configured as shown.

**STORAGE**

**Universal® Overhead Cabinets**

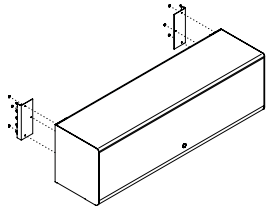

Overhead Cabinet  
 Steel/Fabric/Laminate Door  
 On-Module Mount

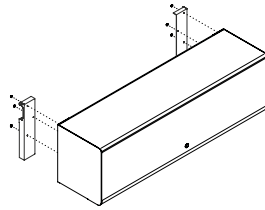

Overhead Cabinet  
 Steel/Fabric/Laminate Door  
 Load Bar Mount

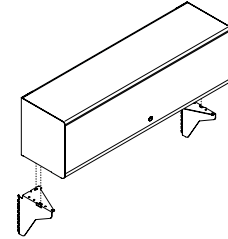

Overhead Cabinet  
 Steel/Fabric/Laminate Door  
 Upmount

**Universal® Storage Low-Height Shelves**

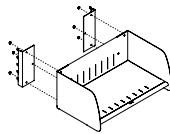

Low Shelf  
 On-Module Mount

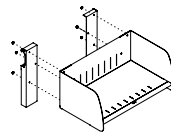

Low Shelf  
 Load Bar Mount

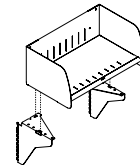

Low Shelf  
 Upmount

**Universal® Storage Regular Height Shelves**

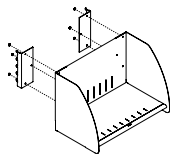

Regular Shelf  
 On-Module Mount

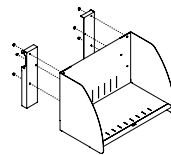

Regular Shelf  
 Load Bar Mount

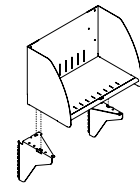

Regular Shelf  
 Upmount

**Venus® Overhead Cabinets**

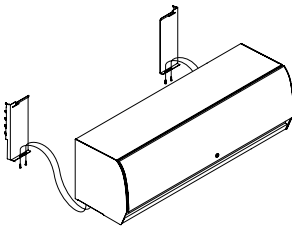

Overhead Cabinet  
 Color/Fabric/Laminate Upper Door  
 On-Module Mount

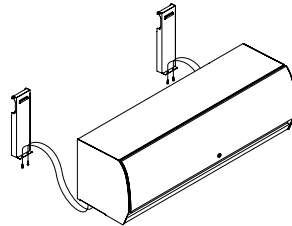

Overhead Cabinet  
 Color/Fabric/Laminate Upper Door  
 Load Bar Mount

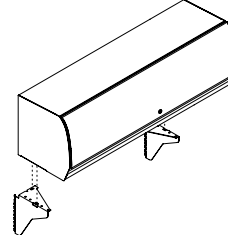

Overhead Cabinet  
 Color/Fabric/Laminate Upper Door  
 Upmount

■ Legion® Panel System – Product Overview - Storage  
 Planning Guide

**Vini® Overhead Cabinets**

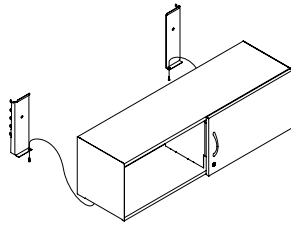

Vini Overhead Cabinet  
 Color Sliding Door  
 On-Module Mount

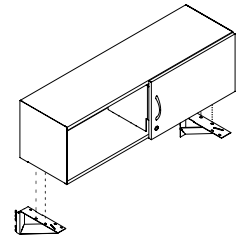

Vini Overhead Cabinet  
 Color Sliding Door  
 Upmount

**Vini® Underhead Cabinets**

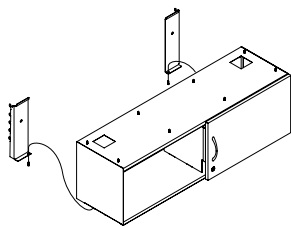

Vini Underhead Cabinet  
 Color Sliding Door  
 On-Module Mount

**Universal® Overhead Accessories**

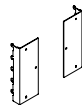

Overhead Cabinet  
 On-Module  
 Mounting Bracket

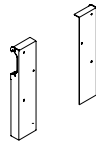

Overhead Cabinet  
 Load Bar  
 Mounting Bracket

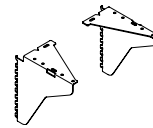

Overhead Cabinet  
 Upmount  
 Mounting Bracket



Shelf Divider

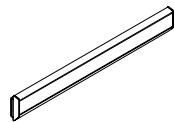

Wall Mounted  
 Load Bar

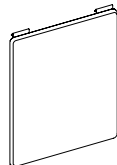

Overhead Cabinet  
 Tackboard

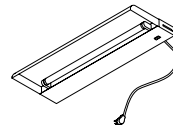

Overhead Cabinet  
 Task Light (Universal)

**Venus® Overhead Cabinet Accessories**

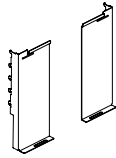

Overhead Cabinet On-Module Mounting Bracket

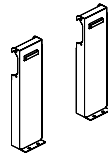

Overhead Cabinet Load Bar Mounting Bracket

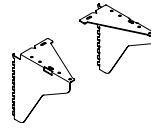

Overhead Cabinet Upmount Mounting Bracket



Shelf Divider

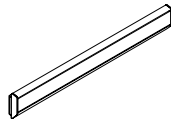

Wall Mounted Load Bar

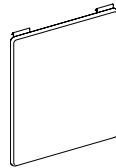

Overhead Cabinet Tackboard

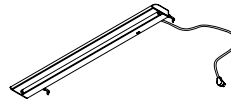

Overhead Cabinet Task Light (Venus)

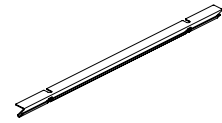

Tackboard/Tool Rail Attachment Bar

**Vini® Overhead Cabinet Accessories**

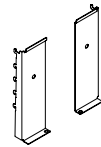

Overhead Cabinet On-Module Mounting Bracket

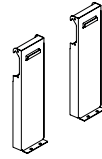

Overhead Cabinet Load Bar Mounting Bracket

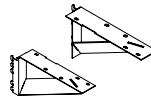

Overhead Cabinet Upmount Mounting Bracket

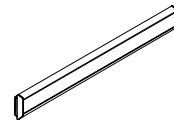

Wall Mounted Load Bar

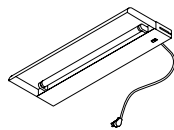

Overhead Cabinet Task Light (Vini)



LED Task Light (Vini)

**Vini® Underhead Cabinet Accessories**

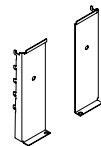

Underhead Cabinet On-Module Mounting Bracket

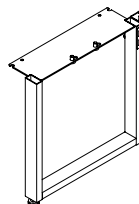

Underhead Cabinet Support Leg

**Storage Components**

**Overhead Storage**

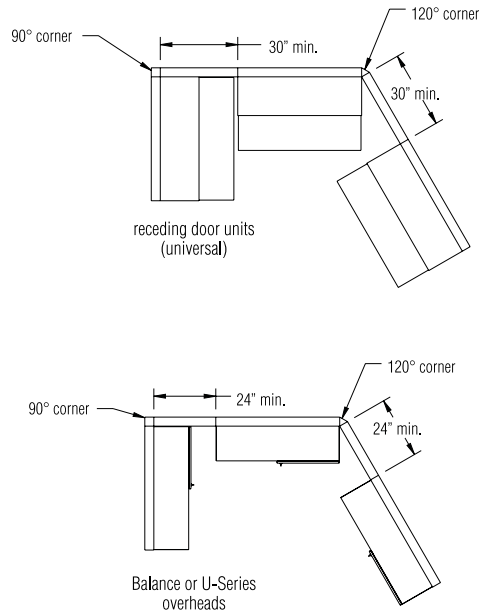

- A Legion panel may support only one overhead storage unit.
- Overhead storage units may **NOT** be hung from STACKING PANEL SECTIONS.
- An overhead with a receding door (Universal Overhead) located in a corner must be adjacent to a perpendicular panel of no less than 30" wide, if the open door is to clear a second overhead positioned 90° or 120° from the first.
- Overheads without receding doors (Vini or Venus) located in a corner must be adjacent to a perpendicular panel of no less than 24" wide if the open door is to clear a second overhead positioned 90° from the first.
- Vini Overhead doors slide from side to side. One side of cabinet will remain open with a center partition. However, the door only locks on the right side. Consider customer preference.

**Pedestal Storage**

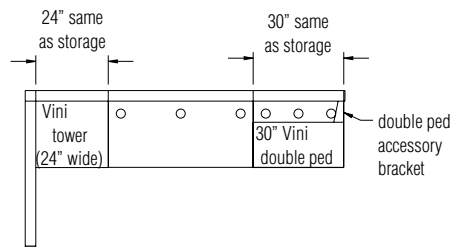

- A single panel-wrapped pedestal can be the same width as that of the panel behind the storage unit. Return panels will stay in place with the use of carpet grippers.
- If panel-wrapping side-by-side pedestal units, the panels behind the pedestals must be at least 6" wider than the combined width of the pedestal units.

Example: Two 24" Vini Pedestals = 48" wide.  
 Use a panel combination that equals at least 54" behind the lowers.

- If the pedestals are adjacent to a worksurface, or functioning as a return panel, the panels behind the pedestal may equal the width of the storage.

**Underhead Storage**

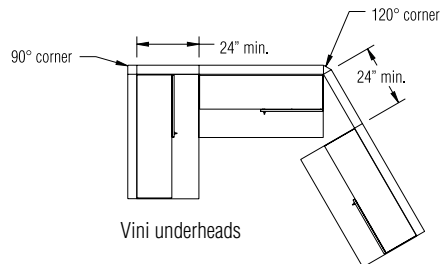

- A Legion panel may support only one underhead storage unit. Underheads restrict leg room and are typically used in conjunction with adjacent, more open working areas. **Note:** Underheads **CANNOT** be hung on the same Legion panel as Overheads.
- Underheads located in a corner must be adjacent to a perpendicular panel of no less than 24" wide if the open door is to clear a second underhead positioned 90° from the first.
- Underhead doors slide from side-to-side. One side of cabinet will remain open with a center partition. However, the door only locks on the right side. Consider customer preference.

**Universal® Overhead Cabinets**

**Steel/Fabric/Laminate Front Overhead Cabinet**

Basic Model: PRDS (steel), PRDE (fabric) & PRDL (laminate)

Steel end panels, bottom and top shelf with powder-coat finish, double bit lock is included. Front door is offered with powdercoat, fabric or laminate. Door stores recessed with PVC handle exposed. Shelf depth is 13 1/4". Overhead tackboard and overhead tool rail can be suspended from underside of the cabinet. Key alike is available.

Width: 24", 30", 36", 42", 48", 54", & 60"

Height: 16 1/2"

Depth: 14 1/2"

**On-Module Mount**

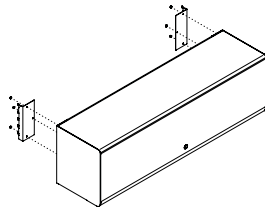

- On-module overheads (PM) mount into slots in vertical posts
- Overheads must be same width as panel mounted to
- Allows for vertical adjustment in 1" increments
- Cannot span panels

**Load Bar Mount (building wall)**

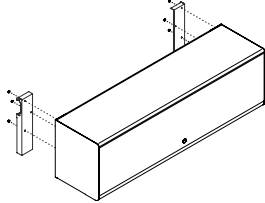

- Load bar mount overheads (LB) hang from an externally mounted load bar on a building wall
- Load bar purchased separately

**Upmount**

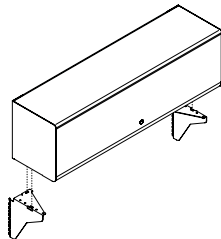

- On a 48" panel, clearance between the Universal overhead and 29" high worksurface is 18.85"
- On a 56" panel, clearance between the Universal overhead and 29" high worksurface is 26.85"
- Cannot span panels

**Universal® Storage Shelves**

**Low Storage Shelf**

Basic Model: ULSR

Steel end panels and bottom shelf. Accepts shelf dividers. End panel bracket design prevents accidental dislodging of components. Shelf depth is 13 1/4". Includes 5" high back. Overhead tackboard and overhead tool rail can be suspended from underside of the shelf.

Width: 24", 30", 36", 42", 48", 54", & 60"

Height: 9 1/2"

Depth: 14 1/2"

**On-Module Mount**

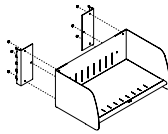

- On-module shelves (PM) mount into slots in vertical posts. Shelves must be same width as panel mounted to. Allows for vertical adjustment in 1" increments.

**Load Bar Mount (building wall)**

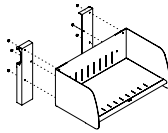

- Load bar mount shelves (LB) hang from an externally mounted load bar on a building wall.
- Load bar purchased separately.

**Upmount**

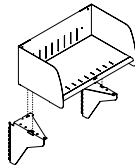

- On a 48" panel, clearance between the Universal shelf and 29" high worksurface is 18.85".
- On a 56" panel, clearance between the Universal shelf and 29" high worksurface is 26.85".

**Regular Storage Shelf**

Basic Model: URSR

Steel end panels and bottom shelf. Accepts shelf dividers. End panel bracket design prevents accidental dislodging of components. Shelf depth is 13 1/4". Includes full back. Overhead tackboard and overhead tool rail can be suspended from underside of the shelf.

Width: 24", 30", 36", 42", 48", 54", & 60"

Height: 16 1/2"

Depth: 14 1/2"

**On-Module Mount**

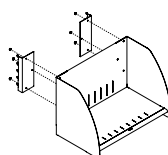

- On-module shelves (PM) mount into slots in vertical posts.
- Shelves must be same width as panel mounted to.
- Allows for vertical adjustment in 1" increments.

**Load Bar Mount (building wall)**

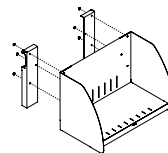

- Load bar mount shelves (LB) hang from an externally mounted load bar on a building wall.
- Load bar purchased separately.

**Regular Storage Shelf Upmount**

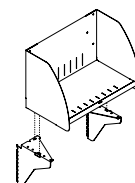

- On a 48" panel, clearance between the Universal shelf and 29" high worksurface is 18.85".
- On a 56" panel, clearance between the Universal shelf and 29" high worksurface is 26.85".



**Venus® Overhead Cabinets**

**Color or Translucent PVC/Fabric/Laminate Upper Door Overhead Cabinet**

Basic Model: BLCF

Steel end panels, bottom and top shelf with powder-coat finish. Upper door is offered in colored/translucent PVC, fabric or laminate. Light, easy open door (less than 5 lb. force).

Height: 17" to accommodate footscap binders – approximately 14" inside clearance

Width: 36", 42", 48", and 60". 30" and 54" available

Depth: 19<sup>3</sup>/<sub>4</sub>"

**On-Module Mount**

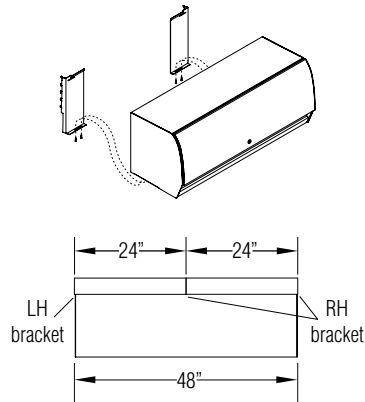

- On-module overheads mount into slots in vertical posts.
- Overheads must be same width as panel mounted to.
- Allows for vertical adjustment in 1" increments.
- Can span two panels with addition of right hand bracket at center.

**Load Bar Mount (building wall)**

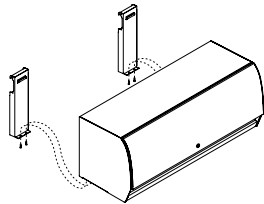

- Load bar mount overheads (LB) hang from an externally mounted load bar on a building wall.
- Load bar purchased separately.

**Upmount**

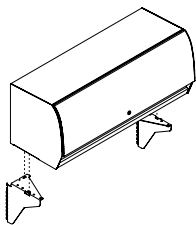

- Upmounted brackets raise the storage 12".
- On a 48" panel, clearance between the Balance overhead and 29" high worksurface is 18.85".
- On a 56" panel, clearance between the Balance overhead and 29" high worksurface is 26.85".
- Cannot span panels.

**Vini® Overhead Cabinets**

**Steel Sliding Door Overhead Cabinet**

Basic Model: VSSDO

Steel end panels, bottom and divider with powder-coat finish. Door slides from side-to-side and one side remains open with center partition. Lockable sliding door extends slightly beyond the center of underhead and only locks on the right side. Overhead accommodates standard binders.

Height: 14<sup>7</sup>/<sub>16</sub>"

Width: 35<sup>3</sup>/<sub>4</sub>", 41<sup>3</sup>/<sub>4</sub>", 47<sup>3</sup>/<sub>4</sub>", 59<sup>3</sup>/<sub>4</sub>" and 71<sup>3</sup>/<sub>4</sub>".

Depth: 14<sup>7</sup>/<sub>8</sub>"

**On-Module Mount**

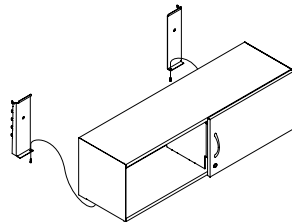

- On-module overheads mount into slots in vertical posts.
- Overheads must be same width as panel mounted to.
- Allows for vertical adjustment in 1" increments.
- Door locks right side only. Left side available as special only.
- Can span two panels with addition of right hand bracket at center.

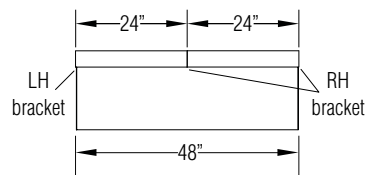

**Upmount**

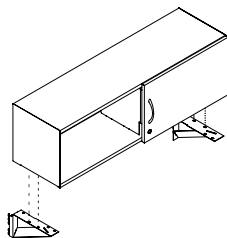

- Upmounted brackets raise the storage 12".
- On a 48" panel, clearance between the U-Series overhead and 29" high worksurface is 18.85".
- On a 56" panel, clearance between the U-Series overhead and 29" high worksurface is 26.85".
- Cannot span panels.

**Vini® Underhead Cabinet**

**Steel Sliding Door Underhead Cabinet**

Basic Model: VHS

Steel end panels, bottom and divider with powder-coat finish. Door slides from side-to-side. One side remains open with center partition. Lockable sliding door extends slightly beyond the center of underhead and only locks on the right side. Underhead accommodates standard binders.

Height: 14<sup>7</sup>/<sub>8</sub>"

Width: 36", 42", 48", 60" and 72"

Depth: 14<sup>7</sup>/<sub>8</sub>"

**On-Module Mount**

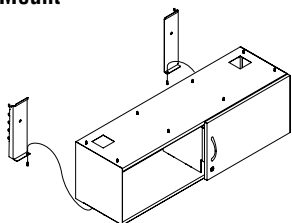

- On-module underheads mount into slots in vertical posts.
- Overheads must be same width as panel mounted to.
- Allows for vertical adjustment in 1" increments.
- Optional Legion grommets can be specified at either end (center grommet not allowed)
- Door locks right side only. Left side available as special only.
- Cannot span panels.

**Universal® Overhead Accessories**

**Overhead Cabinet, On-Module Mounting Brackets**

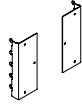

- Sold in pairs, black only.
- Mounts into slots in vertical posts.
- Allows for vertical adjustments in 1" increments.
- Only necessary to order if changing mounting style.

**Overhead Cabinet, Load Bar Brackets (building wall)**

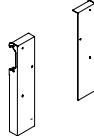

- Sold in pairs.
- Load bar mount overheads hang from an externally mounted load bar on a building wall.
- Load bar purchased separately.

**Overhead Cabinet, Upmount Brackets**

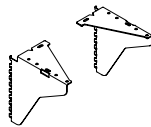

- On a 48" panel, clearance between the Universal overhead and 29" high worksurface is 18.85".
- On a 56" panel, clearance between the Universal overhead and 29" high worksurface is 26.85".
- Sold in pairs.

**Universal Shelf Divider**



- Steel shelf dividers with powder-coated finish.
- Fits on all shelves and cabinets.
- Only necessary to order if changing mounting style.

**Wall Mounted Load Bar**

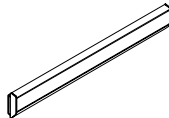

- Supports overhead storage on drywall or other non-panel applications.
- Wide range of widths available, see Legion Price List.

**Overhead Tackboard**

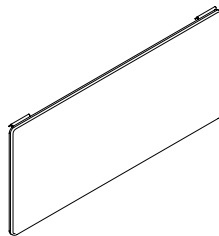

- Hangs from bottom of overhead cabinet or shelf.
- Includes mounting brackets in black only.
- Wide range of sizes available, see Legion Price List.
- Available in two different options: either load bar mounted overhead cabinets or panel mounted overhead cabinets. How the overhead is mounted will determine which overhead tackboard to order.
- Width: 24", 30", 36", 42", 48", 60".
- Height: 12", 16".

**Overhead Cabinet & Shelf Task Light**

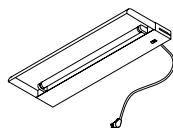

- Electronic ballast.
- Width: 18", 24", 36", 48".

**Venus® Overhead Cabinet Accessories**

**Overhead Cabinet, On-Module Mounting Brackets**

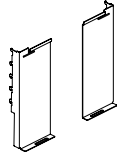

- Sold in pairs.
- Mounts into slots in vertical posts.
- Black only.

**Overhead Cabinet, Load Bar Brackets (building wall)**

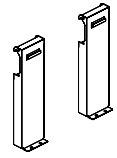

- Sold in pairs.
- Load bar mount overheads (LB) hang from an externally mounted load bar on a building wall.
- Load bar purchased separately.

**Overhead Cabinet, Upmount Brackets**

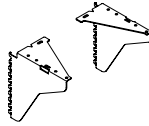

- Sold in pairs.
- On a 48" panel, clearance between the Venus overhead and 29" high worksurface is 18.85".
- On a 56" panel, clearance between the Venus overhead and 29" high worksurface is 26.85".

**Overhead Cabinet Shelf Divider**



- Steel shelf dividers with powder-coat finish.
- Fits on all shelves and cabinets.

**Wall Mounted Load Bar**

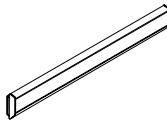

- Supports overhead storage on drywall or other non-panel applications.
- Wide range of widths available, see Legion Price List.

**Overhead Tackboard**

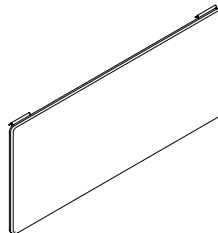

- Hangs from bottom of overhead cabinet or shelf.
- When hanging from Venus overhead, specify attachment bar BMB (purchase separately).
- Includes mounting brackets in black only.
- Available in two different options: either load bar mounted overhead cabinets or panel mounted overhead cabinets. How the overhead is mounted will determine which overhead tackboard to order.
- Width: 24", 30", 36", 42", 48", 60".
- Height: 12", 16".

**Tackboard/Tool Rail Attachment Bar**

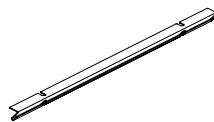

- Attachment bracket which secures to bottom of overhead to accept Venus overhead tackboard.
- Order same size as overhead cabinet.
- 18-gauge steel.
- Black only.
- Width: 30", 36", 42", 48", 60".

**Overhead Task Lights**

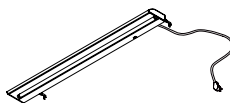

- Electronic ballast.
- Task lights mount flush with underside of overhead cabinets and shelves.
- Includes mounting straps.
- Includes 9' cord.
- UL Listed.
- For use with cabinet width: 30", 36", 42", 48", 54", 60".

**Vini® Overhead  
 Cabinet Accessories**

**Overhead Cabinet, On-Module Mounting Brackets**

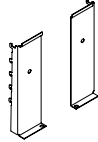

- Sold in pairs.
- Mounts into slots in vertical posts.
- Black only.

**Overhead Cabinet, Load Bar Brackets (building wall)**

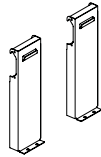

- Sold in pairs.
- Load bar mount overheads (LB) hang from an externally mounted load bar on a building wall.
- Load bar purchased separately.

**Overhead Cabinet, Upmount Brackets**

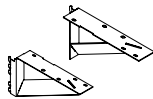

- Sold in pairs.
- On a 48" panel, clearance between the Vini overhead and 29" high worksurface is 18.85".
- On a 56" panel, clearance between the Vini overhead and 29" high worksurface is 26.85".

**Wall Mounted Load Bar**

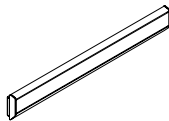

- Supports overhead storage on drywall or other non-panel applications.
- Wide range of widths available, see Legion Price List.

**Overhead Cabinet & Shelf Task Light**

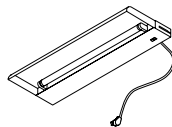

- Electronic ballast.
- Width: 18", 24", 36", 48".

**Vini® Underhead  
 Cabinet Accessories**

**Underhead Cabinet, On-Module Mounting Brackets**

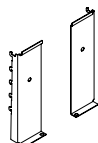

- Sold in pairs.
- Mounts into slots in vertical posts.
- Black only.

**Underhead Cabinet, Support Leg**

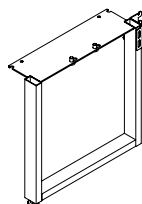

- Sold as left or right-hand legs
- Mounts into slots in vertical posts.
- Standard colors available.



## ACCESSORIES

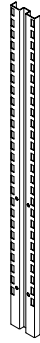

Wall Track

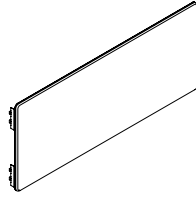

On-Module Tackboard



Adjustable  
Wall Mount  
Start

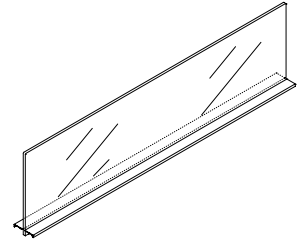

Glass Divider

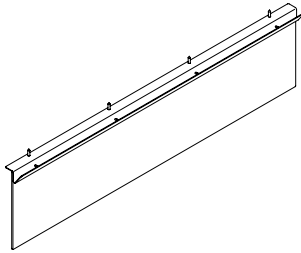

Modesty Panel

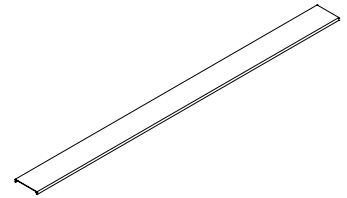

Continuous Top Cap

Accessories

Wall Track

Basic Model: UNWT

Wall Track allows for mounting worksurfaces, overheads and hang on components to building walls without the use of Legion panels. No attachment hardware is included. Wall Track is available in 30" and 64" heights. The 30" height is designed to hang worksurfaces only. Worksurfaces can be mounted over the track and flush against the building wall. The 64" height allows worksurfaces, overheads and hang on components while complimenting all Legion panel heights. Worksurfaces cannot be flush against wall on 64" height.

Height: 30" & 64"

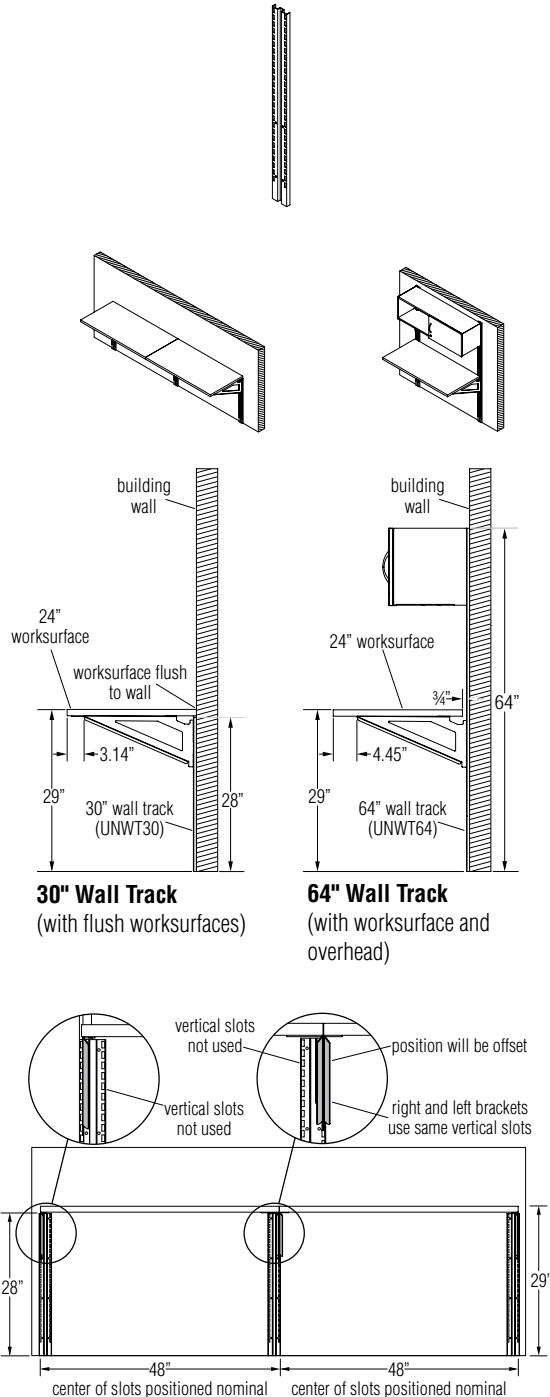

**30" Wall Track**  
(with flush worksurfaces)

**64" Wall Track**  
(with worksurface and overhead)

**30" Wall Track**  
(flush worksurface front view)

- All mount holes in the wall track should be used to attach to wall.
- Recommended that the wall track starts at the floor.
- When wall track is installed next to a system panel; slots and mounting brackets can be aligned so that worksurface tops are flush.
- Recommended that worksurface supporting pedestals be specified to provide additional support to wall track mounted worksurfaces.

**Caution:** Wall track **MUST** be anchored to one of the following wall types:

- **Concrete Wall:** Anchor with good quality concrete anchor installed to the manufacturer's recommendations.
- **Dry (mineral) Wall:** Wall track must be mounted into wood or steel wall studs. Secure to wood studs using a #10 x 2 1/2" wood screw or a hollow wall anchor (toggle bolt) installed into the steel stud to the manufacturer's recommendations.
- **Dry (Mineral) Wall:** Dry wall over 3/8" minimum thick plywood with no studs. Secure to wall using a hollow wall anchor (toggle bolt) installed according to the manufacturer's recommendations.
- Worksurfaces that are hung on 30" or 64" wall track will have a 1 5/16" space between the back of the worksurface and the wall. If desired, the 30" height wall track allows the work surface to mount flush to the building wall. Mount bracket in top slot of wall track. Surface can be mounted above the wall track and pushed against the building wall. This option changes the planned surface depth and associate rules by 1 5/16". It is as if the worksurface was 1 5/16" less deep since the position of the bracket relative to the wall track does not change. Therefore, unique bracket configuration is required.

**Accessories (cont.)**

**On-Module Tackboards**

Basic Model: LGTB

Legion Tackboards are designed to hang "On-Module". They are designed with tooth brackets that engage slots in the Legion vertical frame posts. Tooth brackets are shipped pre-assembled on the Tackboard.

Height: 12", 16", 20", 30", 48"  
 Width: 24", 30", 36", 42", 48", 60"

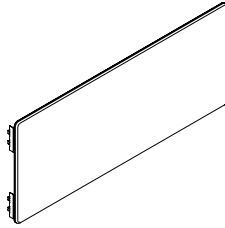

- Tackboards hang "on-module" only.
- Can be used with wall track with the same space configurations as shown.
- Cannot hang two side by side on a Legion 72" wide panel since there are no slots at center post.
- Raising worksurfaces in 1" increments will reduce tackboard space above the worksurface by 1" increments.

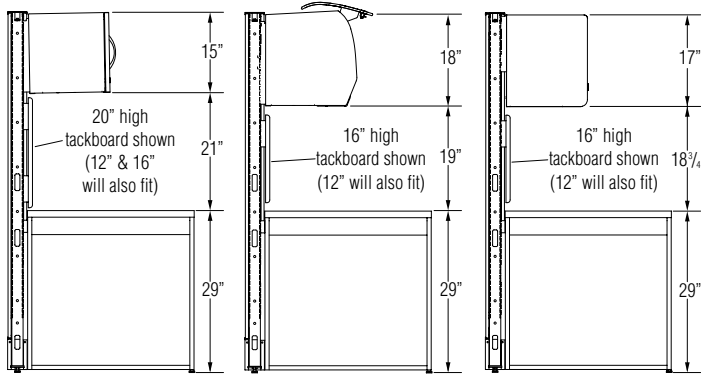

	29" High Worksurface		26" High Worksurface	
Storage	Space Available	Tackboard Height	Space Available	Tackboard Height
Vini	21"	12", 16" & 20"	24"	12", 16" & 20"
Venus	19"	12 & 16"	22"	12", 16" & 20"
Universal	18 <sup>3</sup> / <sub>4</sub> "	12 & 16"	21 <sup>3</sup> / <sub>4</sub> "	12", 16" & 20"

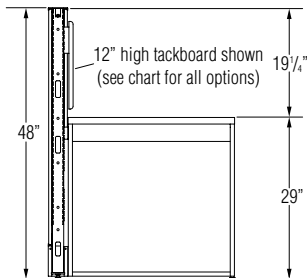

**No Overhead**

	29" High Worksurface		26" High Worksurface	
Height	Space Available	Tackboard Height	Space Available	Tackboard Height
32"	3 <sup>1</sup> / <sub>4</sub> "	None	6 <sup>1</sup> / <sub>4</sub> "	None
40"	11 <sup>1</sup> / <sub>4</sub> "	None	14 <sup>1</sup> / <sub>4</sub> "	12"
48"	19 <sup>1</sup> / <sub>4</sub> "	12" & 16"	22 <sup>1</sup> / <sub>4</sub> "	12", 16" & 20"
56"	27 <sup>1</sup> / <sub>4</sub> "	12", 16" & 20"	30 <sup>1</sup> / <sub>4</sub> "	12", 16", 20" & 30"
64"	35 <sup>1</sup> / <sub>4</sub> "	12", 16", 20" & 30"	38 <sup>1</sup> / <sub>4</sub> "	12", 16", 20", 30" & 36"



**Accessories (cont.)**

**Hang-On Tackboards**

Basic Model: PTBO

Legion Hang-On Tackboards are designed to hook or hang on a bar under Venus and Universal overheads and shelves. Hang-On style Tackboards are not available under Vini overheads. The Tackboard can be hung on overheads or shelves that are mounted on a panel or on a load bar. The Tackboard width does not have to match the panel width. However, the width must be equal to or less than the storage unit.

Height: 12" & 16"  
 Width: 24", 30", 36", 42", 48", 60"

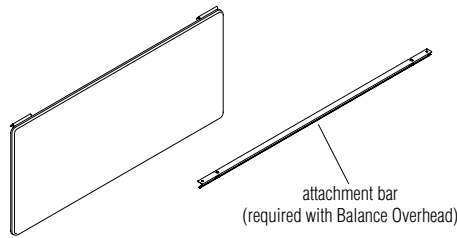

**Note:** Overheads shown for reference; shelves are similar.

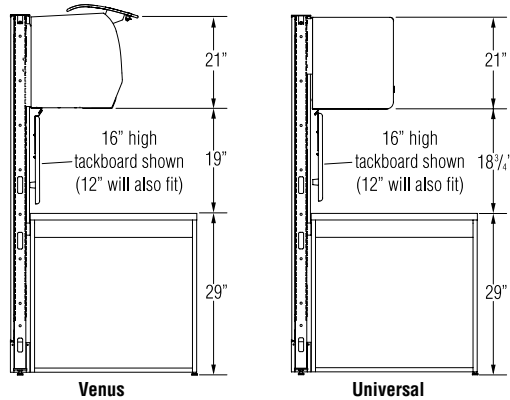

**Hang-On Tackboards with Overheads Mounted to a Panel (NLBI)**

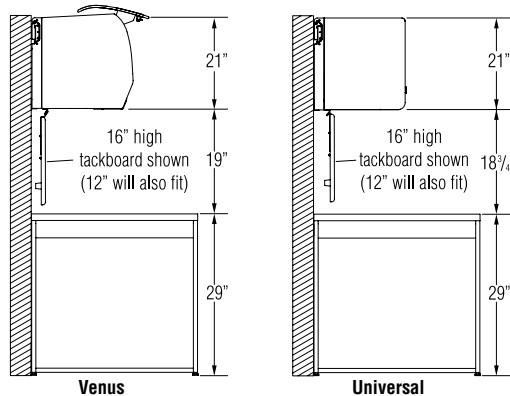

**Hang-On Tackboards with Load Bar Mounted Storage on Building Wall (YLBM)**

- Tackboard hangs from the bottom of an overhead or shelf.
- See chart for space restrictions.
- Legion offers 26" high worksurfaces that will increase space between storage and worksurface by 3" (see chart below).
- Width should be equal or less than the storage width.
- When hanging from Venus, specify attachment bar BMB.size (purchased separately). Bar must be same width as storage unit.
- Tackboard cannot be specified with wall track.
- Specify NLBM (No Load Bar Mount) when the overhead is mounted on a panel. Specify YLBM (Yes Load Bar Mount) when the overhead is mounted on a loadbar.
- The only difference between NLBM and YLBM is the overhead mounting bracket.
- Tackboard can hang and over-lap panel segment or tool rail.
- Raising worksurfaces in 1" increments will reduce tackboard space above the worksurface by 1" increments.

Storage	29" High Worksurface		26" High Worksurface	
	Space Available	Tackboard Height	Space Available	Tackboard Height
Venus	19"	12" & 16"	22"	12", 16" & 20"
Universal	18 3/4"	12" & 16"	21 3/4"	12", 16" & 20"

**Note:** Assumes panel height is 70"

Storage	29" High Worksurface		26" High Worksurface	
	Space Available	Tackboard Height	Space Available	Tackboard Height
Venus	19"	12" & 16"	22"	12", 16" & 20"
Universal	18 3/4"	12" & 16"	21 3/4"	12", 16" & 20"

**Note:** Depending on wall height, more space can be created in between overhead and worksurface by mounting the load bar and overhead further up the wall.

**Accessories (cont.)**

**Adjustable Wall Mount Start**

Basic Model: UNWM

Used to attach Legion Panels to existing building walls. Wall Mounts are adjustable from top to bottom which allows plum attachment to building walls that are not perfectly vertical. Wall mounts are powdercoated to match trim color.

Height: 16", 32", 40", 48", 56", 64", 72" & 80"

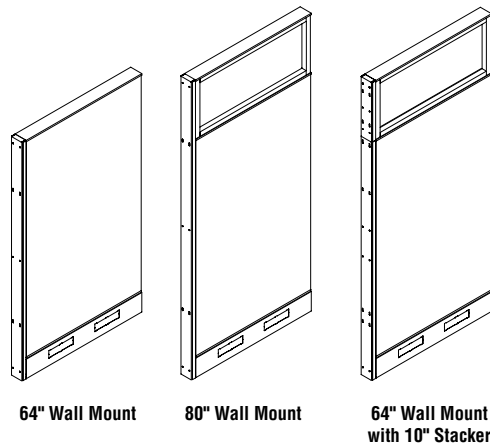
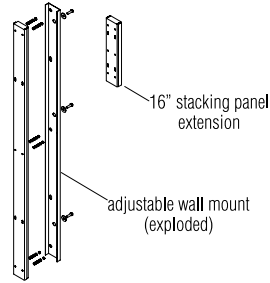

- Can be used with any pre-configured Legion panel including stacking sections.
- 16" wall mount available for stacking panel sections that are space planned after initial installation.
- Adjustable from 1.00" to 1.70" to plum (.70" maximum plum) Legion Panels to existing building walls.
- One wall mount will add a minimum of 1.00" and maximum of 1.70" spacing to building wall from panel end module.
- Overheads may be used but must comply with Legion panel configurations and rules.
- Appropriate wall anchor to dry wall must be provided by contractor.
- If a panel run is located between two building walls where a wall mount is needed on both ends of the panel run, but the extended distance with wall mounts is short, please see the next page.

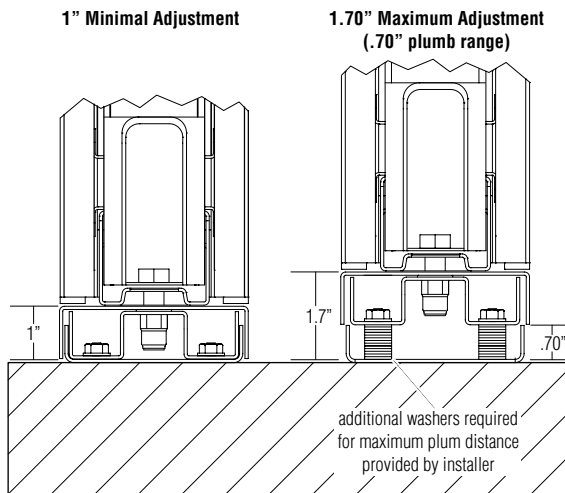

**Accessories (cont.)**

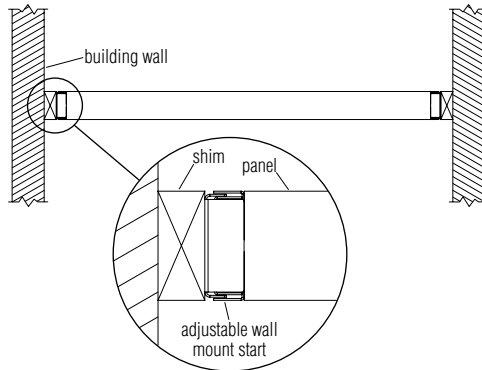

- A shim is needed when a panel run is located between two building walls with a wall mount on both ends of the panel run, but the extended distance with wall mounts is still short.
- Install a shim made of building material to bridge the gap on both sides of the panel. Both shims add up to roughly 6" wide (3" each side). Wider gaps may require a standard building constructed short wall. Shim will have to be paint matched to the building wall. Installer will provide shim or wall materials.

**Adjustable Wall Mount with Shim**

**Glass Divider Screen**

Basic Model: UNGDS

Unframed "tempered" Glass Divider drops into top of panel and replaces standard top cap. Clear and satin etch (one side) glass styles available. Three edges are polished so the glass has a top and bottom. Glass Divider available in all Legion panel widths. Additional widths available to allow two panel spanning.

Height: 12"  
 Width: 24", 30", 36", 42", 48", 54", 60", 66" & 72"

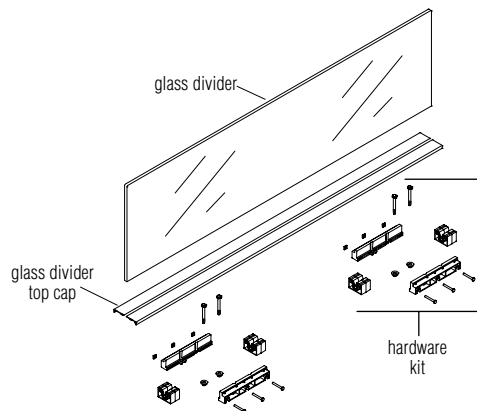

- Connecting hardware and split top cap trim provided.
- Split top cap takes the place of standard Legion top cap. Specify no top cap when ordering glass dividers.
- Do not specify next to "change of height" (COH) panel. **Note:** Glass will contact COH trim. If required, a Special can be ordered.
- Not allowed on top of stacking panel sections.
- Not allowed over segmented glass or segmented perforated steel panels.
- May span multiple panels up to 72" maximum width.
- Specify a support leg at center of span if worksurface is also split there. No support needed if surface is also spanning.
- Support recommended every 8 feet of run to avoid panel bow & uneven glass.
- Standard rules with balanced configurations (ie. surfaces both sides).

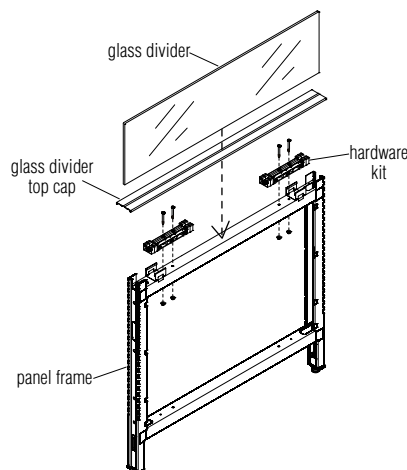

**Installation**

**Accessories (cont.)**

**Continuous Top Cap**

Basic Model: HRDPT

Used in place of standard top cap for uninterrupted spans between intersections. To specify, add together nominal panel widths.

Width: 6' Maximum

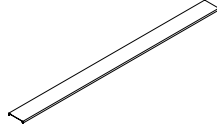

**Note:** Legion panels may be specified with optional spanning top caps of up to 6'.

- It is recommended that you order all panels that will utilize spanning top caps as NO TOP CAP to minimize waste.
- Add up the total nominal width of panels that you wish to span.

Example: Spanning one 24" panel and one 48" panel would require a  $24" + 48" = 72"$  top cap.

**Accessories (cont.)**

**Frameless Modesty Panels**

Basic Model: UMODA

Modesty Panels mount under Legion worksurfaces and are typically used on perpendicular or peninsula surfaces attached to a panel spine. Frameless Modesty Panels can also attach to Legion Stand Alone Tables. A powder-coat painted metal bracket attaches the modesty panel to the worksurface with screws. The insert material is acrylic, available in a variety of colors per the color addendum. Modesty panels are available in all Legion Worksurface widths.

Height: 10 1/4"  
 Width: 24", 30", 36", 42", 48", 54", 60", 66" & 72"

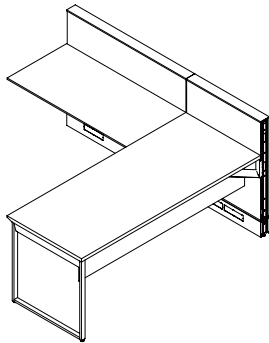
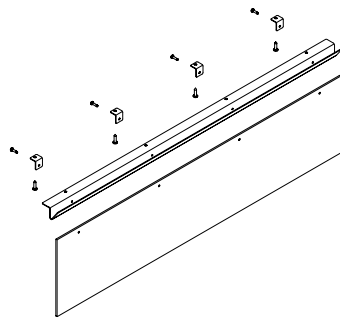

**Perpendicular Worksurface**

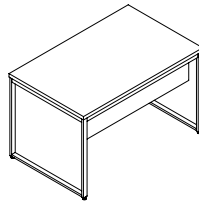

**Freestanding Table**

- Model sizes listed refers to worksurface length. Actual length of modesty panel is approximately 5 1/2" shorter than nominal.
- Due to the 2 3/4" set-back of the modesty panel, grommet holes cannot be used. **Note:** Grommets can be used if the 12" design bracket is replaced with a standard cantilever bracket (see below).
- Modesty panels can be used with Legion stand alone tables and 74P edge.
- Modesty panels can span across two worksurfaces. Total length of surface edge must match modesty panel model.
- Layouts below indicate some typical configurations.
  - All worksurface depths can be used (ie. 18", 22", 24" & 30").
  - Length of worksurface and frameless modesty panel model should match.
  - Modesty panels do not fit with two post legs at worksurface end.
- Please consult engineering for non-typical configurations.

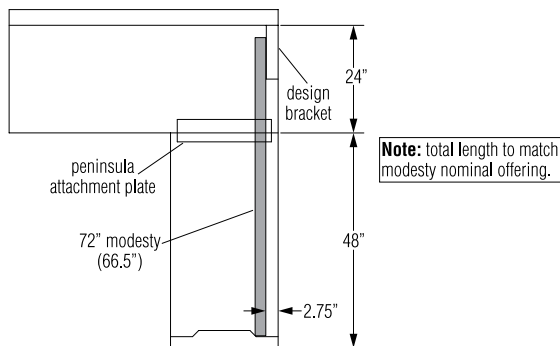

**Add-on Peninsula Worksurface Spanning Modesty Panel**

**Accessories (cont.)**

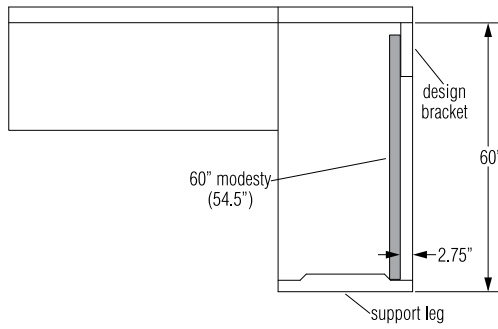

**Perpendicular Worksurface Modesty Panel**

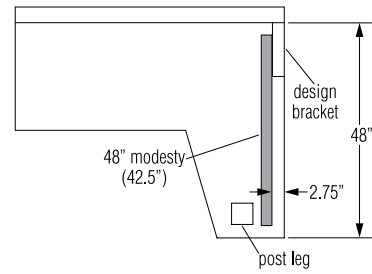

**Tapered Peninsula Worksurface Modesty Panel**

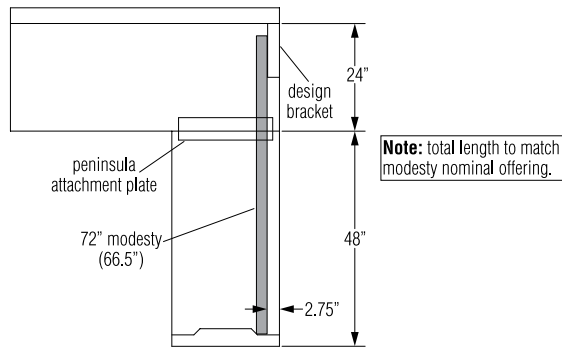

**Add-on Peninsula Worksurface Spanning Modesty Panel**

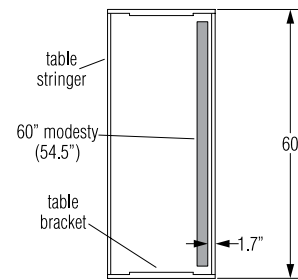

**Stand Alone Table with 74P Edge & Modesty Panel**

