

# Assembly Instructions ■

Legion® System Rolling Door

September 2017

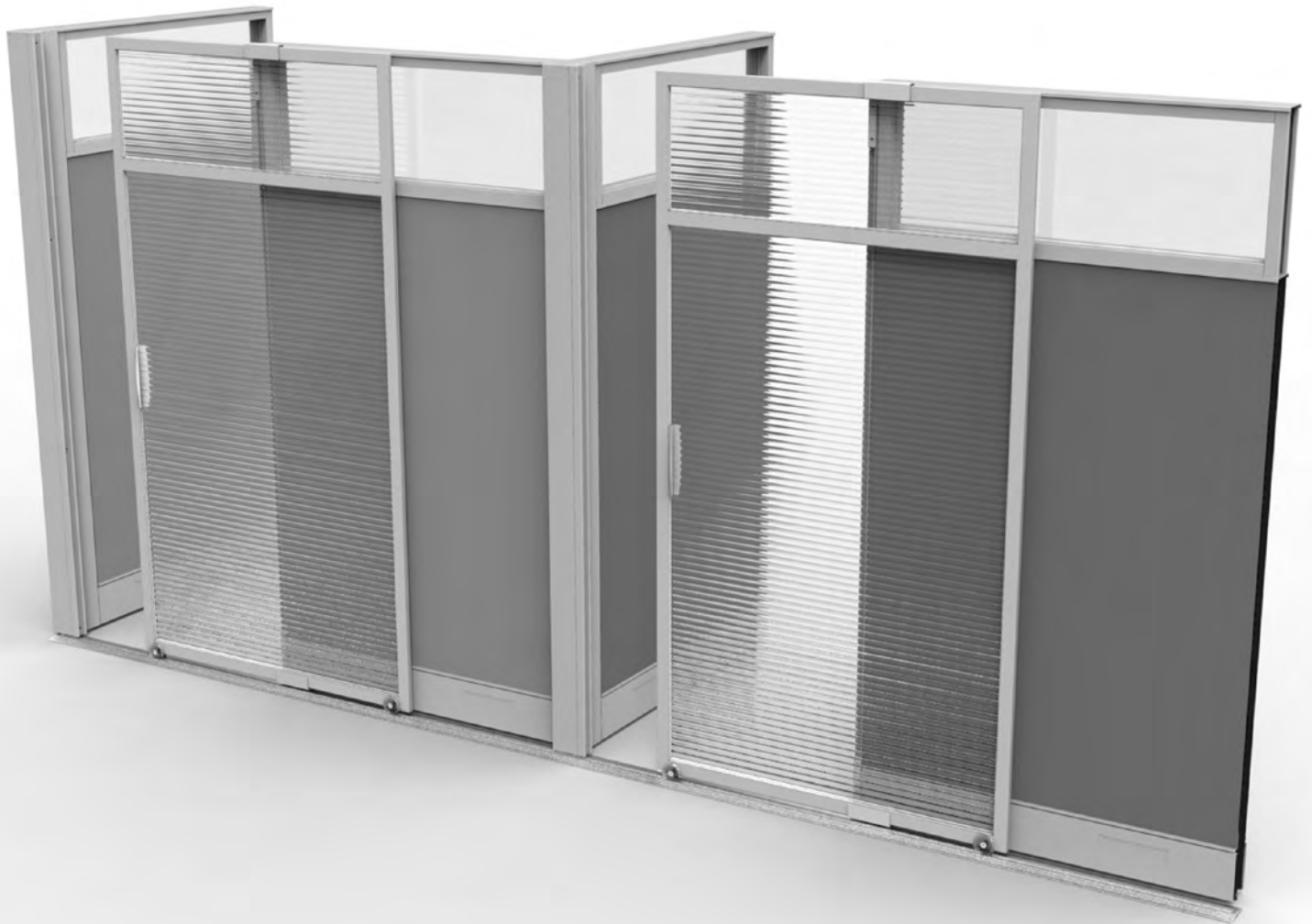

# ■ Legion® System Rolling Door - Overview

## Assembly Instructions

### Legion® System Rolling Door

End-of-Run Attaching Trim Installation .....	3
Guide Bracket Installation.....	4
Rolling Door Wheel Installation.....	6
Rolling Door to Frame Installation.....	7
Post Installation .....	9
No-Jamb Rolling Door Option.....	9
Inline (180°) Jamb Post Installation.....	12
90° Corner Jamb Post Installation .....	15
Dead End Jamb Post Installation.....	18
Double Dead End Jamb Post Installation.....	21
Building Wall Jamb Post Installation.....	24
Closing Jamb Rolling Doors Configurations.....	25
Rolling Door Threshold Accessory Installation .....	27
Threshold Typical Configuration .....	28

### ROLLING DOOR OVERVIEW

#### Rolling Door Sizes

Rolling Doors are offered in the following sizes:

- 36" w X 64" h (monolithic door core)**
- 36" w X 80" h (segmented door core)**
- 42" w X 64" h (monolithic door core)**
- 42" w X 80" h (segmented door core)**

The width dimension provided indicates the nominal opening width that the door will span, and the actual door is oversized to allow for panel overlap. 64" high doors are constructed with a single aluminum frame. 80" high doors have a 16" high segmented top section to correspond to a 16" high Legion stacking section.

#### Panel Attachment and Specification

The panel to which a Rolling Door is attached must be specified the same width or wider than the nominal Rolling Door model (i.e. 36" w door with 36" or wider attach panel). The No Jamb model must be specified with a 6" or wider attaching panel (i.e. 36" w model with 42" w or wider attaching panel). This prevents the door from extending open into an adjacent walkway. This rule is not required if the attaching panel is a member of a panel run.

#### 80" High Segmented Door

All Rolling Door models shown in this manual are 80" high, and feature 16" segmented top frames. 64" Rolling Door models are monolithic and do not feature any segmentation.

#### Handedness of Models

All Rolling Door models are "non-handed". Wheel assemblies are packaged separately from the door for unilateral application. Jamb post assemblies are reversible for right or left side assembly.

**IMPORTANT:** Ensure jamb posts and jamb rails are correctly positioned in place prior to drilling holes. This will ensure proper orientation of the door before permanent holes are made.

#### Tools Required

- Power drill 1/8" drill bit and Philips drive bit (for jamb rail).
- Two clamps with plastic protective jaws (for jamb rail).
- 4mm (5/32") and 5mm (3/16") Allen key wrench (for wheel).
- Socket wrench and two 9/16" deep well sockets (for jamb post).



Assemble units as described herein only. To do otherwise may result in instability. All screws, nuts and bolts must be tightened securely and must be checked periodically after assembly. Failure to assemble properly, or to secure parts may result in assembly failure and personal injury.

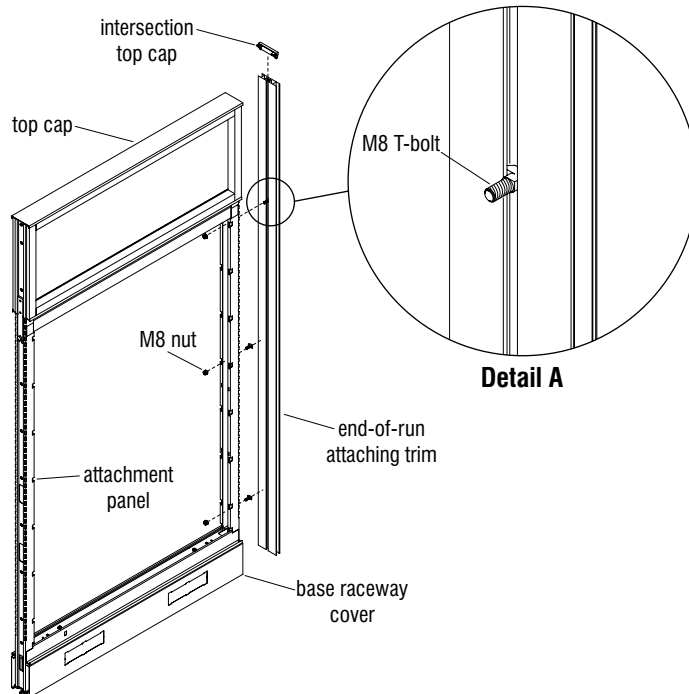

**Figure 1**

### End-of-Run Attaching Trim Installation

**Note:** Legion Panel with glass section (80" high) is shown as reference. Your panel/ configuration may vary.

1. Insert three M8 T-bolts down into the slot on the back side of the vertical end-of-run attaching trim as shown (Figure 1 & Detail A).

**Note:** The M8 hardware used for securing end-of-run attaching trim to frame is the same whether a Rolling Door assembly uses a jamb or does not.

2. Position the three M8 T-bolts in the end-of-run attaching trim to align with mounting holes in the panel frame vertical post. One should be near the lowest hole on the vertical post of the frame, one near the middle and one near the upper hole as illustrated (Figure 1).
3. Install the special intersection top cap at this time to help align the end-of-run trim (Figure 1). The top cap of the attachment panel should be in place so the intersection cap can be installed to form a good fit at the top corner (Figure 1).
4. Ensure the end-of-run trim is flush with the base raceway cover (or foot shroud for lifted base) and that the T-bolts are aligned with their respective holes. Install the three M8 nuts to the T-bolts and tighten the end-of-run trim in place (Figure 1).

# Legion® System Rolling Door - Guide Bracket

Assembly Instructions

## Guide Bracket Installation

5. At the location where a rolling door is to be installed, remove the intersection top cap if not already done so (Figure 2).
6. At the isle side of the end-of-run trim, position two clamp blocks as illustrated, with mounting holes showing out and insert blocks into the opening as shown (Detail C). Place one block at the top of the attaching trim and slide one bracket to the bottom of the trim (Figure 2 & Detail B).

**Important:** For the step below, ensure the "U" shape of the upper and lower guide brackets face each other as illustrated. Tighten screws into the plastic blocks until brackets are snug but can still slide for final adjustment.

7. Next, correctly position the upper and lower door guide brackets in place as illustrated and install using two #10-16 x 3/4" Phillips flat head self-drilling Tek Screws. Do not tighten completely at this time (Figure 2, Detail C).

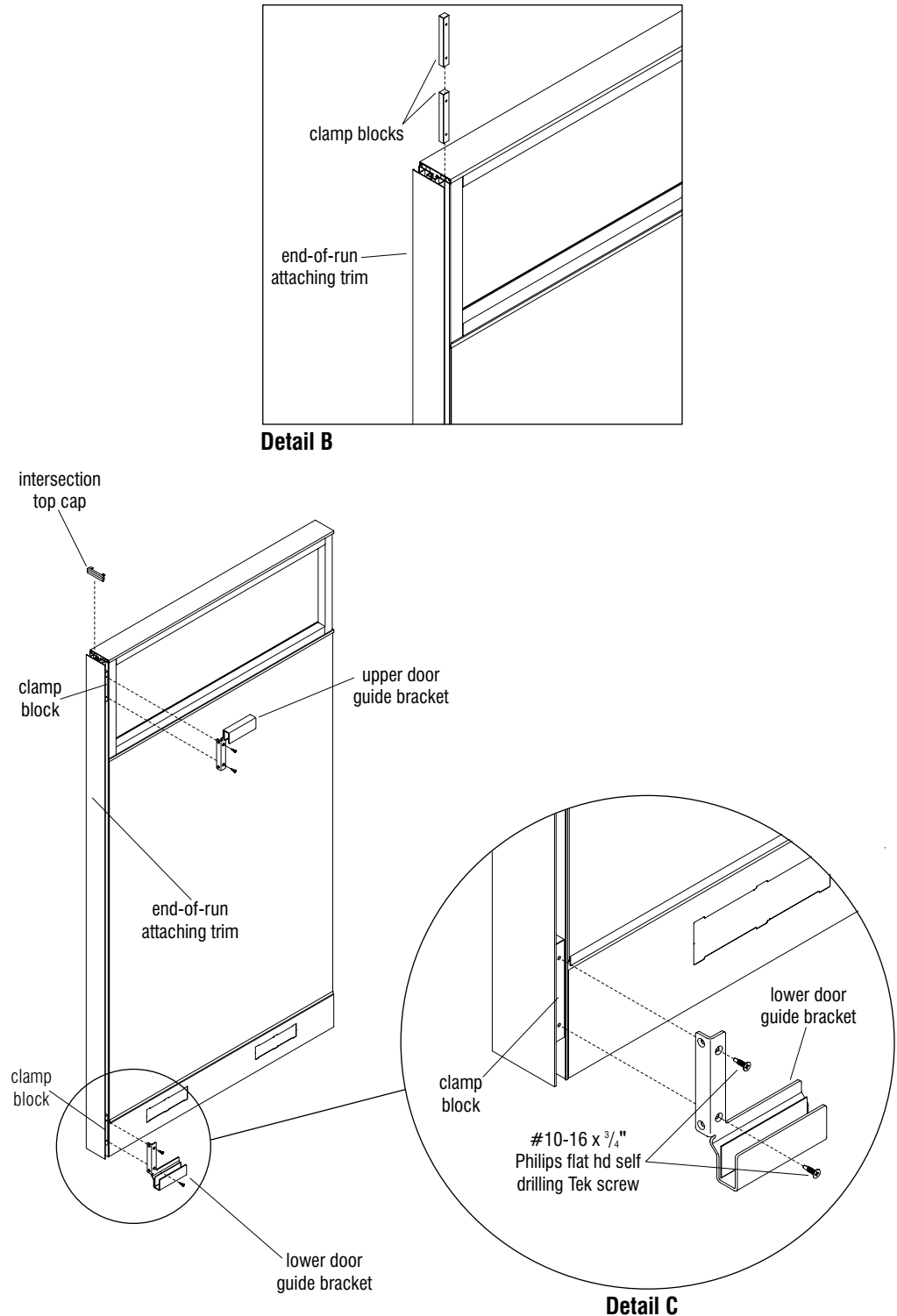

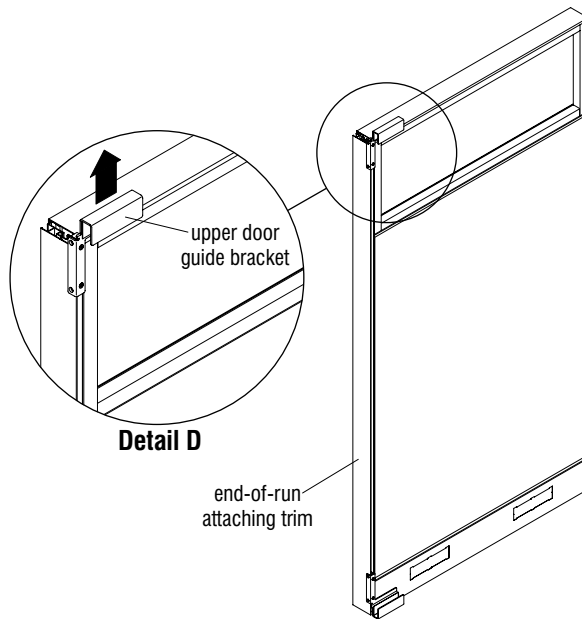

Figure 2

**CAUTION**

Assemble units as described herein only. To do otherwise may result in instability. All screws, nuts and bolts must be tightened securely and must be checked periodically after assembly. Failure to assemble properly, or to secure parts may result in assembly failure and personal injury.



**Figure 3**

**Guide Bracket Installation cont.**

8. The door guide bracket installed to clamp block should be snug, but not tight. Slide the upper door guide bracket upward in the slot, to make room for installation of rolling door (Figure 3, Detail D).

**Note:** The four (two at each bracket) #10-16 x  $\frac{3}{4}$ " self-drilling Tek screws for final door guide bracket attachment to face of attaching trim should not be installed at this time.

### Rolling Door Wheel Installation

**Note:** Two identical wheel assemblies are packaged and included with each Rolling Door.

**Note:** Rolling doors are shipped “non-handed”, so ensure the handle is facing the desired open and closing direction. Install the wheels on the isle side of the door to avoid contact with the base raceway (Detail E).

9. At the front (isle side) of the rolling door, insert the 1/4-20 connector nut through the wheel and washer as illustrated and press into the adjustment slot and press into the adjustment slot. At the back (non-isles side) insert a 1/4-20 connector bolt into the slot and twist into the connector nut (Figure 4 & Detail E).
10. Tighten the wheel assembly to rolling door frame using a 5mm Allen key for the nut and 4mm Allen key for the bolt. Do not over-tighten (Figure 4 & Detail E).

**Note:** The hole for each connector bolt is a slot which allows the wheels to be adjusted up or down. This will ensure the door is plumb and square against the jamb rail(s). Wheel assemblies can be adjusted at any time.

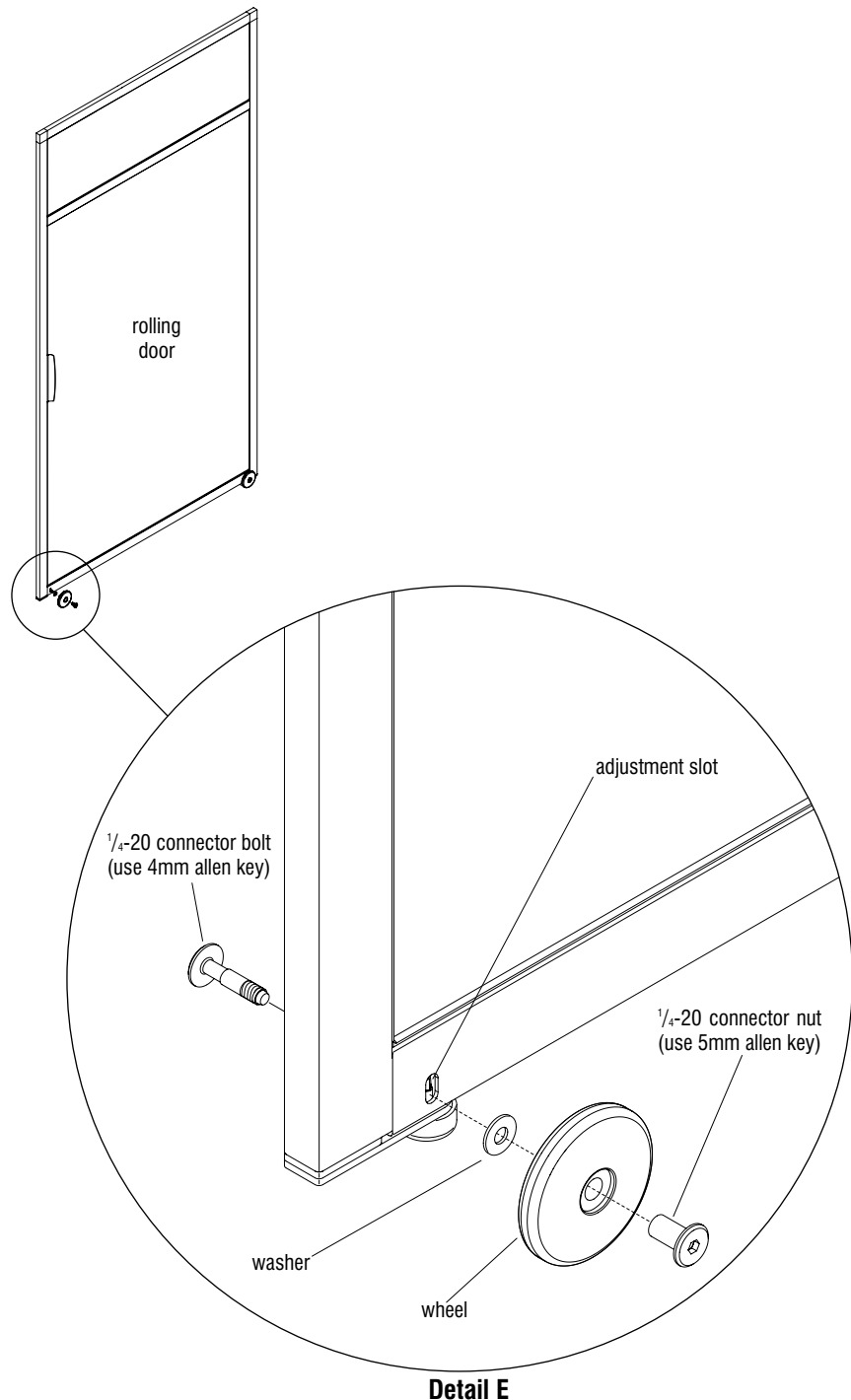
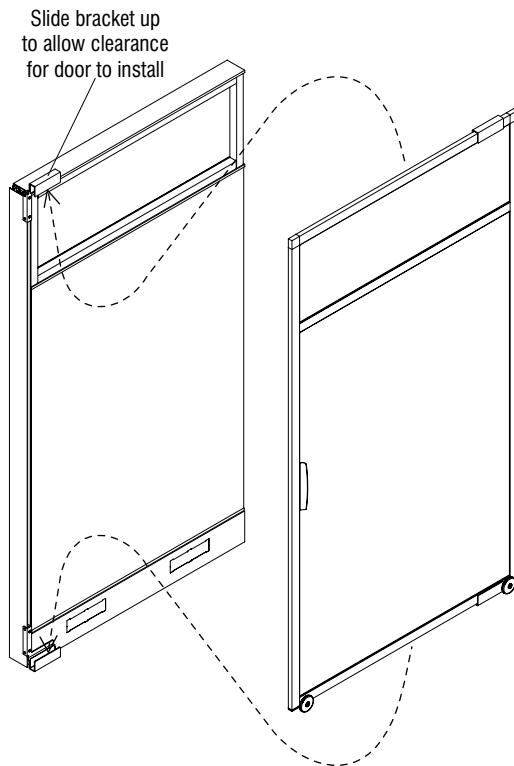

Figure 4



Assemble units as described herein only. To do otherwise may result in instability. All screws, nuts and bolts must be tightened securely and must be checked periodically after assembly. Failure to assemble properly, or to secure parts may result in assembly failure and personal injury.



Slide bracket up to allow clearance for door to install

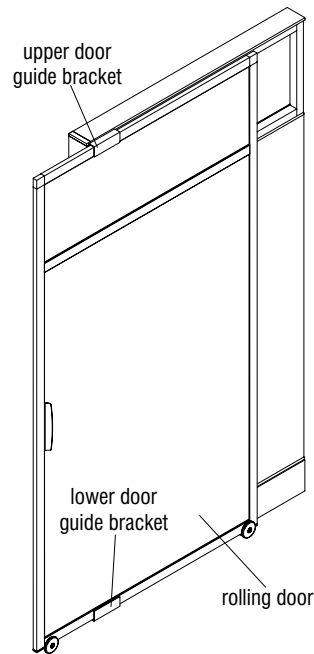

upper door guide bracket

lower door guide bracket

rolling door

Figure 5

### Rolling Door to Frame

11. Position the rolling door with the wheels to the aisle side. Tip the top of the rolling door out and set the center, bottom of the door onto the lower door guide bracket with one wheel positioned on each side of the lower guide bracket as illustrated. (Figure 5).

**Important:** a wheel must be on each side of the guide for the door to operate properly.

12. Adjust rolling door vertically, then lower the upper door guide bracket to capture and hold the door in place. Do not secure at this time (Figure 5).

# ■ Legion® System Rolling Door - Rolling Door to Frame

Assembly Instructions

## Rolling Door to Frame cont.

13. With the upper and lower door guide brackets still snug but not tight, and the rolling door in place, adjust each bracket such that the lip of each bracket is flush with the edge of the horizontal door frame member (Figure 6).
14. Re-Install intersection trim cap (Figure 6).
15. With each upper and lower guide bracket positioned correctly, fasten each bracket to the end-of-run trim using two #10 x 16 Phillips flat head self-drilling Tek screws per bracket. This must be done using a drill and Phillips drive bit (Detail F).

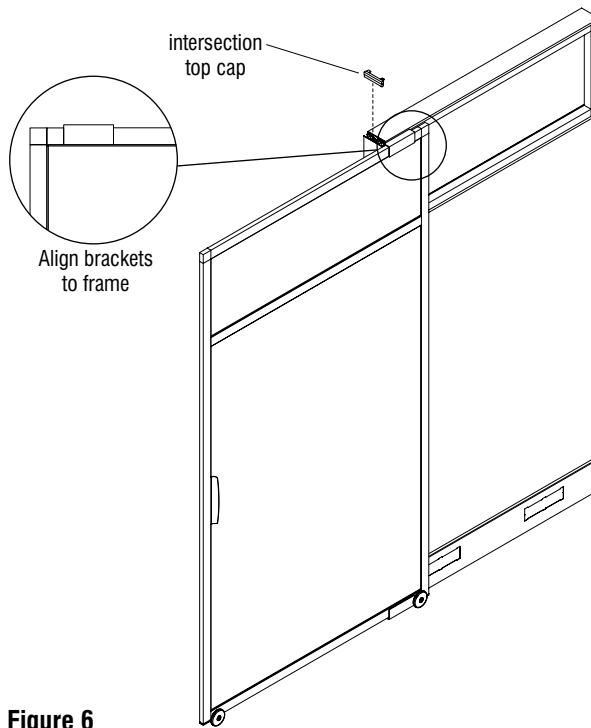
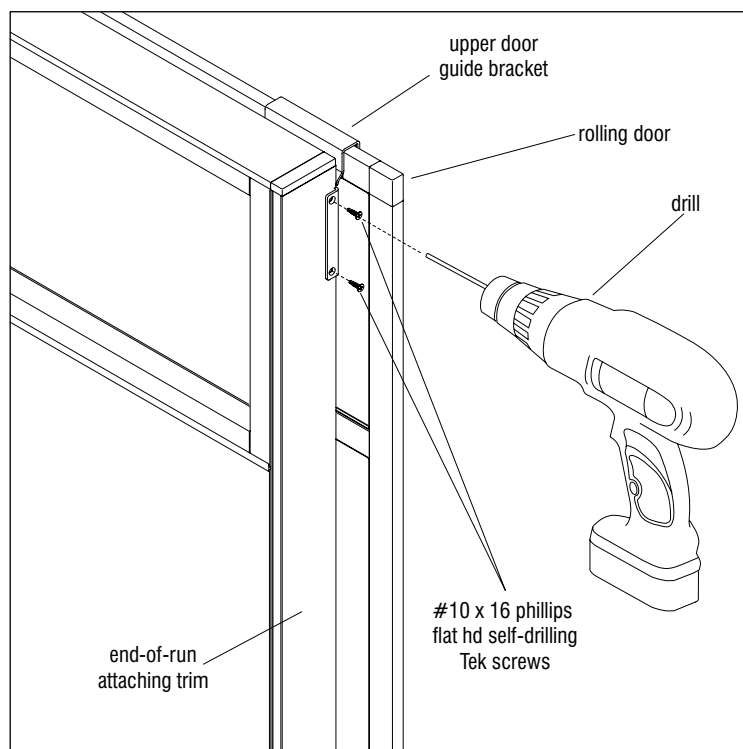

Figure 6



Detail F





Assemble units as described herein only. To do otherwise may result in instability. All screws, nuts and bolts must be tightened securely and must be checked periodically after assembly. Failure to assemble properly, or to secure parts may result in assembly failure and personal injury.

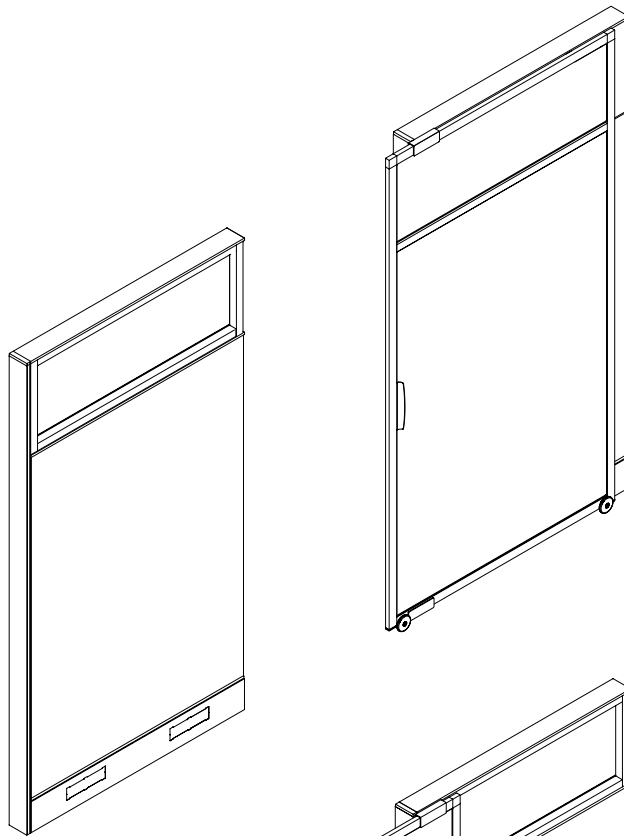

Figure 7

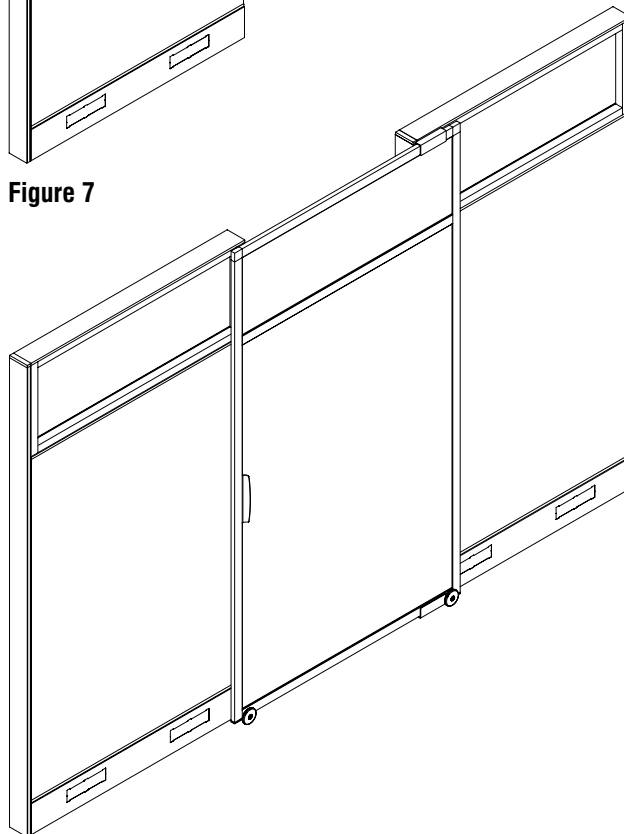

Figure 8

#### No Jamb Rolling Door Option

**Note:** The no jamb rolling door option is specified with no "door closing jamb". Several no jamb configurations are optional (see pages 10 & 11). The space-planning layout determines which option is appropriate at the site. This page depicts one option.

1. Illustrated on this page is a 180° inline no jamb rolling door configuration. The closed rolling door overlaps the adjoining inline panel by approximately 1.5" (Figure 7 & 8).
2. Refer to pages 3 through 8, figures 1 - 6 for proper assembly and installation of the rolling door and components.

■ Legion® System Rolling Door - No Jamb Rolling Door Configurations  
 Assembly Instructions

**No Jamb Rolling Doors Configurations**

All configurations shown below with no jamb can be made using the Rolling Door no jamb. The door overlaps the panel or intersection at the closed end.

- 36" models with typical "closed" and "open" dimensions.
- Inline 180°, 90°, Dead End, Double Dead End.

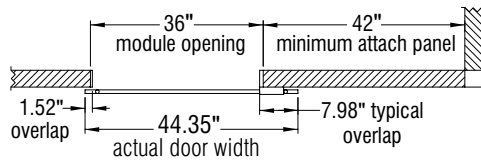

**closed**  
**No Jamb Inline (180°) 36" Rolling Door**

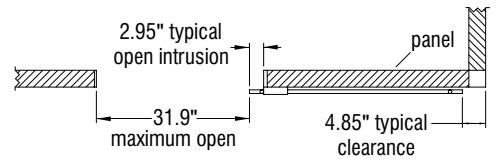

**open**

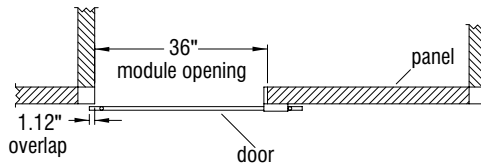

**closed**  
**No Jamb Corner (90°) 36" Rolling Door**

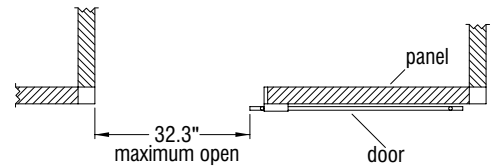

**open**

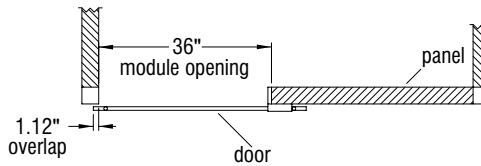

**closed**  
**No Jamb Dead End 36" Rolling Door**

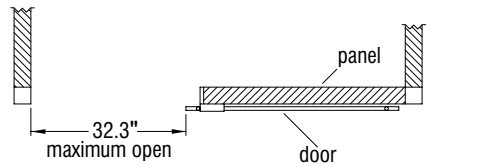

**open**

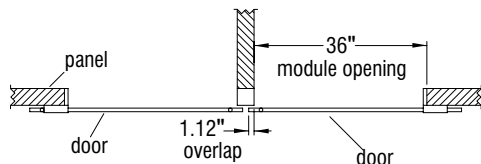

**closed**  
**No Jamb Double Dead End 36" Rolling Door**

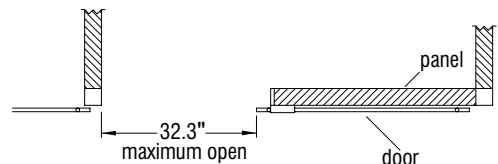

**open**



Assemble units as described herein only. To do otherwise may result in instability. All screws, nuts and bolts must be tightened securely and must be checked periodically after assembly. Failure to assemble properly, or to secure parts may result in assembly failure and personal injury.

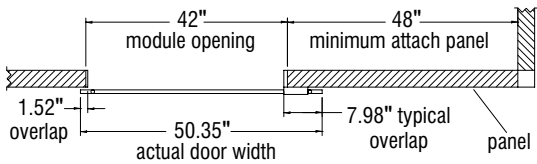

**closed**  
**No Jamb Inline (180°) 42" Rolling Door**

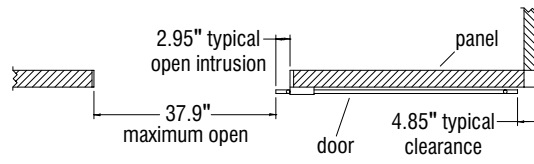

**open**

**No Jamb Rolling Doors Configurations cont.**

- 42" models with typical "closed" and "open" dimensions.
- Inline 180°, 90°, Dead End, Double Dead End

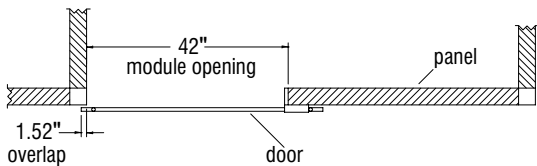

**closed**  
**No Jamb Corner (90°) 42" Rolling Door**

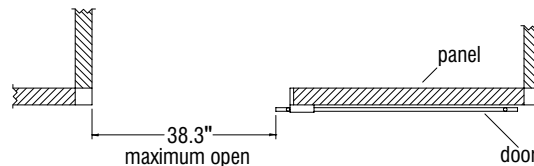

**open**

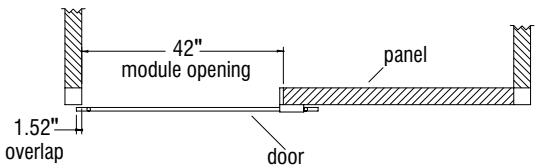

**closed**  
**No Jamb Dead End 42" Rolling Door**

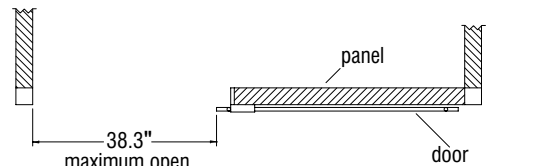

**open**

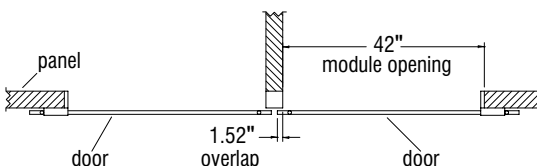

**closed**  
**No Jamb Double Dead End 42" Rolling Door**

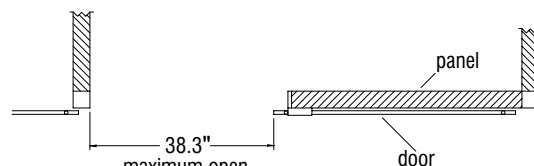

**open**

## ■ Legion® System Rolling Door - Inline (180°) Jamb Post Assembly Instructions

### Inline (180°) Jamb Post Installation

**Note:** The inline jamb post will install to the end of a panel frame, opposite a panel with the rolling door installed to it (see Figure 9). Refer to instructions at the beginning of this manual (pages 3-8, figures 1-6) for proper assembly and installation of the rolling door and components.

1. Position the inline jamb post against the panel frame vertical post such that roughly one inch of the jamb post extends into the walkway. From inside the panel, fasten the jamb post to the vertical post of the panel frame using four  $\frac{3}{8}$ -16 x  $1\frac{1}{4}$ " hex head bolts and washers (Figure 9).
2. Press the jamb post top cap into top of inline jamb post (Figure 9).

**Note:** The inline jamb post is non-handed, and may be oriented on either the right or left side of an opening by simply flipping it over and repositioning the jamb-post top cap.

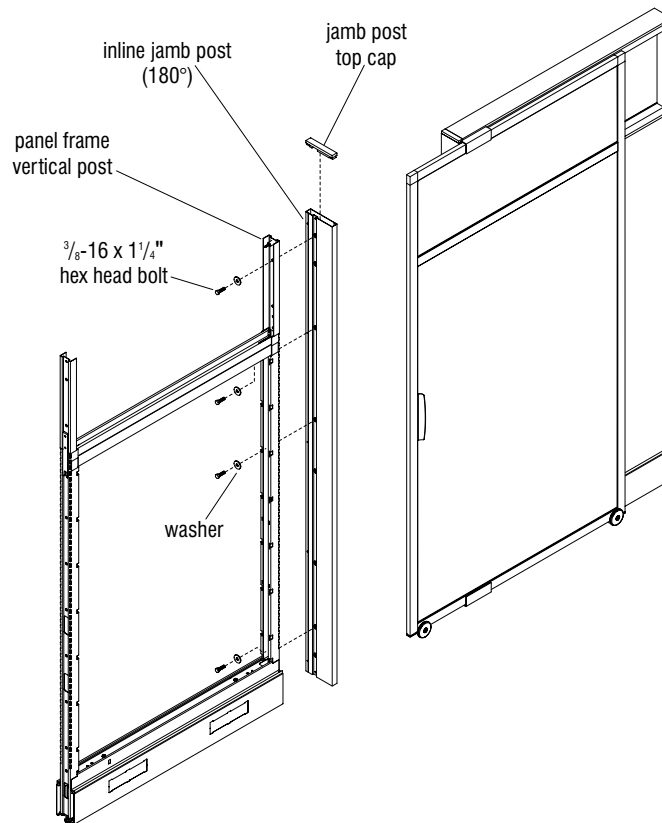

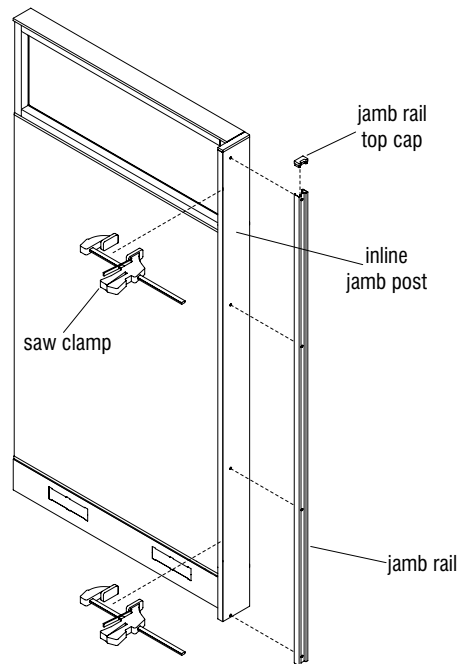

Figure 9



Assemble units as described herein only. To do otherwise may result in instability. All screws, nuts and bolts must be tightened securely and must be checked periodically after assembly. Failure to assemble properly, or to secure parts may result in assembly failure and personal injury.

**CAUTION**



**Figure 10**

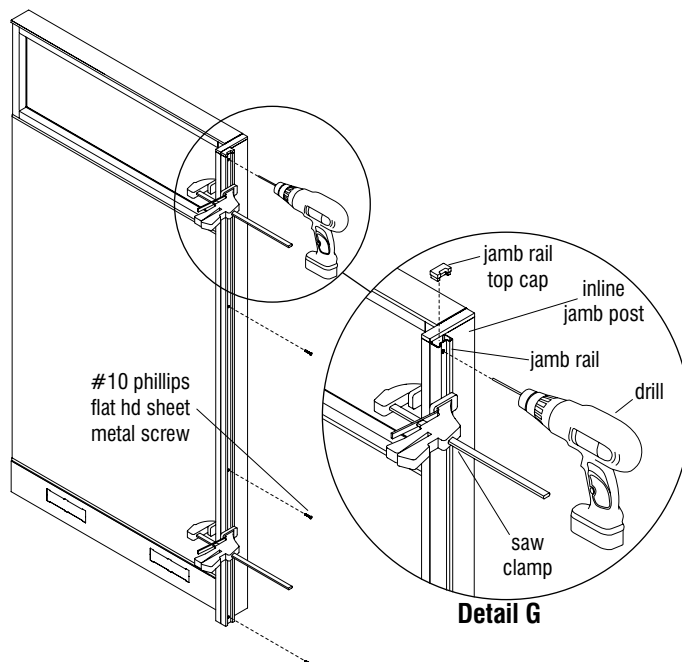

**Figure 11**

**Inline (180°) Jamb Post  
 Installation cont.**

3. Next, locate a jamb rail and make sure a top cap is inserted to the top of the rail. Then position jamb rail against the installed inline jamb post as illustrated. Align the jamb rail top cap height with the inline jamb post top cap height and ensure that the jamb rail is aligned flush to the jamb post at the side, from top to bottom. Using two clamps as illustrated, securely clamp the rail to the post (Figures 10 & 11, Detail G).
4. While the jamb rail is clamped securely and straight, use a 1/8" drill bit and bore holes through the inline jamb post using each of the four jamb rail holes as guides for drilling (Figure 11).
5. Install four #10 Phillips flat head sheet metal screws to secure the jamb rail to the jamb post. Do not over-tighten screws (Figure 11).

# ■ Legion® System Rolling Door - Inline (180°) Jamb Post Assembly Instructions

## Inline (180°) Jamb Post Installation cont.

6. Check "plumb" of the door to the jamb rail by rolling the door closed, then confirm that the door contacts the jamb rail in a square and even manner. If necessary, adjust the door angle by loosening **(DO NOT REMOVE)** one or both wheels and moving the wheel(s) up or down in the adjustment slot, then re-tightening in the new position. Wheel assembly is shown in detail below for reference (Figure 12, Detail H).

**Tip:** The maximum angle of adjustment is achieved when wheels are adjusted in opposite directions up/down.

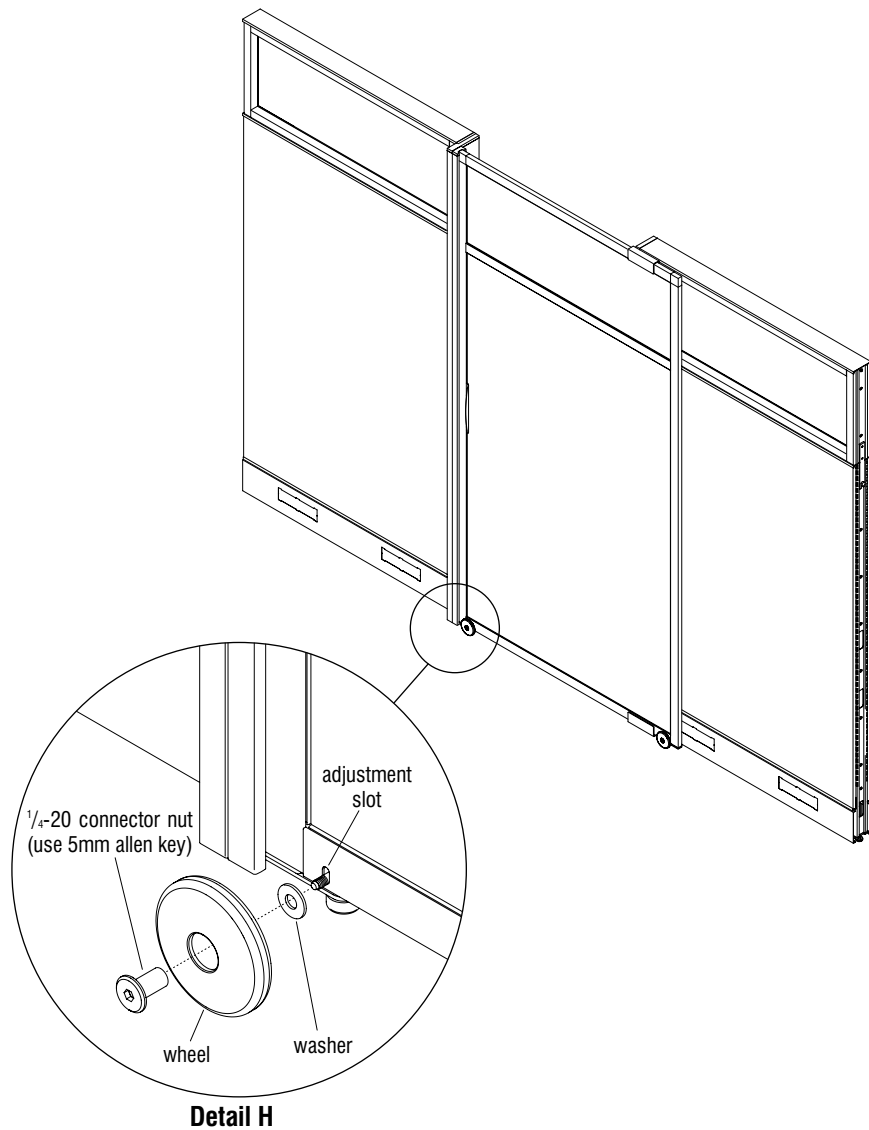

Figure 12

**WARNING:** Assembly of all mechanical frame components must be completed before making any electrical connections. All electrically connected furnishings must also be mechanically connected.



Assemble units as described herein only. To do otherwise may result in instability. All screws, nuts and bolts must be tightened securely and must be checked periodically after assembly. Failure to assemble properly, or to secure parts may result in assembly failure and personal injury.

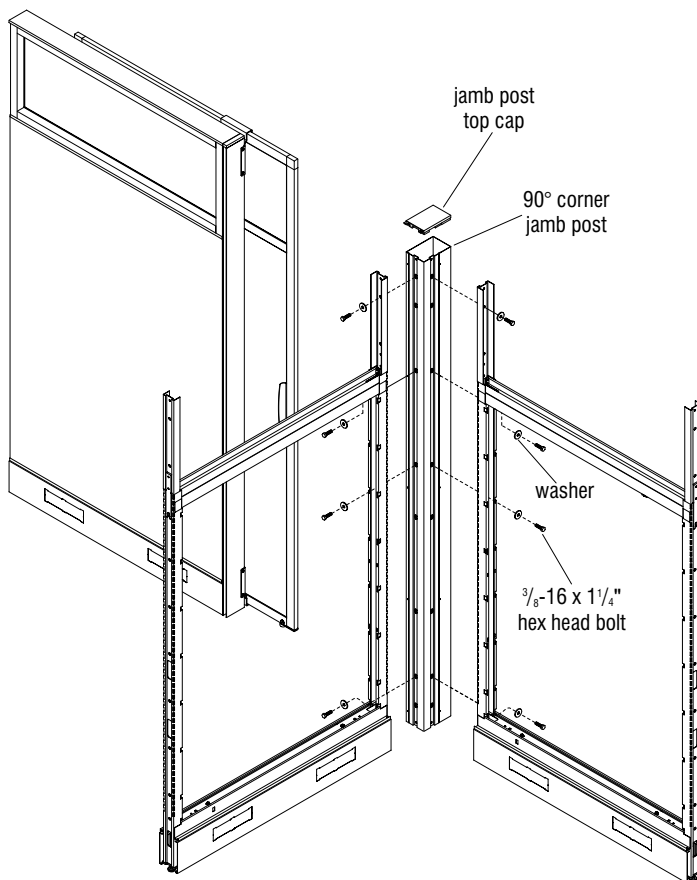

Figure 13

### 90° Corner Jamb Post Installation

**Note:** The 90° corner jamb post is installed where a rolling door closes to meet two panel frames that form a 90° intersection. Refer to instructions at the beginning of this manual (pages 2-7, figures 1-6) for proper installation of the rolling door and components.

**Note:** The rolling door 90° corner jamb post replaces standard Legion panel intersection connector blocks. If reconfiguring a corner, the connector blocks can be discarded.

1. Position the 90° corner jamb post such that approximately 1" of the post extends into the walkway as illustrated. Fasten the jamb post to both panel frames using the  $\frac{3}{8}$ -16 x  $\frac{1}{4}$ " hex head bolts and washers. Install the jamb post top cap (Figure 13).

**Note:** The 90° corner jamb post is non-handed, and may be oriented on either the right or left side of an opening, per the space-planning layout.

# ■ Legion® System Rolling Door - 90° Corner Jamb Post

Assembly Instructions

## 90° Corner Jamb Post Installation cont.

2. Next, make sure a top cap is inserted to the top of the jamb rail, then position jamb rail against the installed 90° corner jamb post as illustrated. Align the jamb rail top cap height with the jamb post top cap height and ensure that the jamb rail is aligned flush to the jamb post at the side, from top to bottom. Using two clamps as illustrated, securely clamp the rail to the post (Figure 14 & Detail I).
3. While the jamb rail is clamped securely and straight, use a  $\frac{1}{8}$ " drill bit and bore holes through the jamb post using each of the four jamb rail holes as guides for drilling (Figure 15).
4. Install four #10 Phillips flat head sheet metal screws to secure the jamb rail to the jamb post. Do not over-tighten screws (Figure 15).

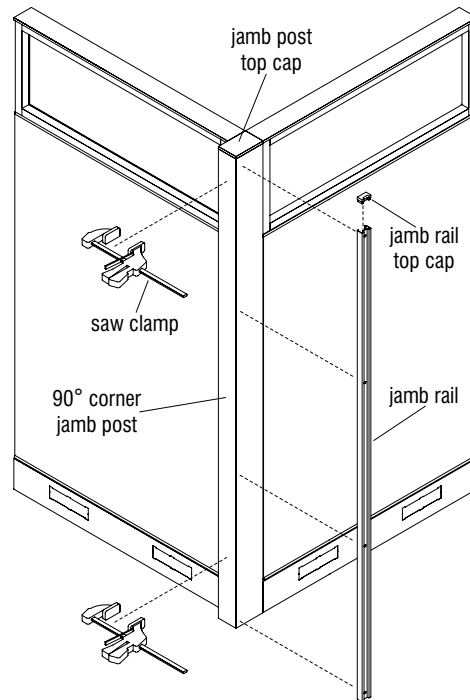

Figure 14

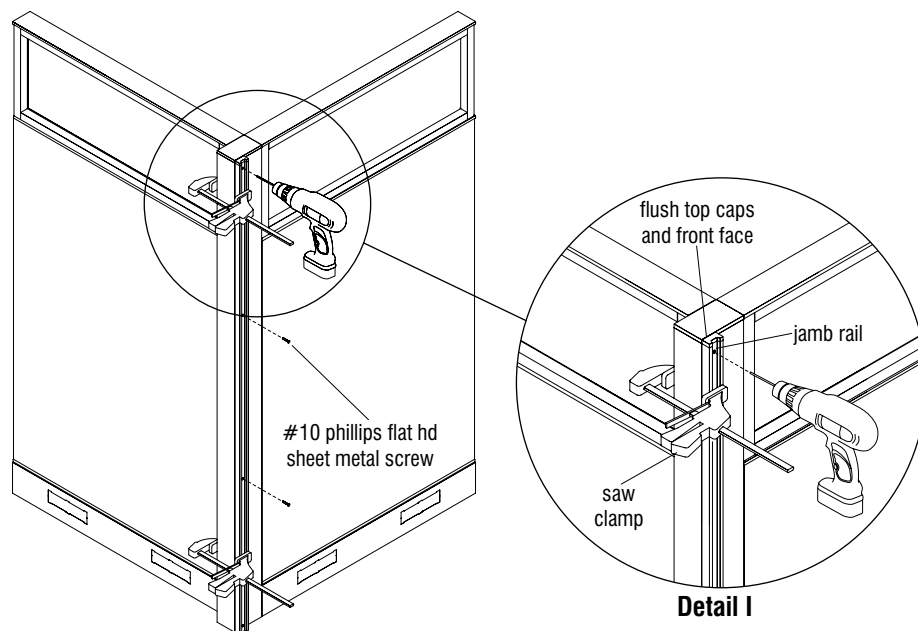

Figure 15





Assemble units as described herein only. To do otherwise may result in instability. All screws, nuts and bolts must be tightened securely and must be checked periodically after assembly. Failure to assemble properly, or to secure parts may result in assembly failure and personal injury.

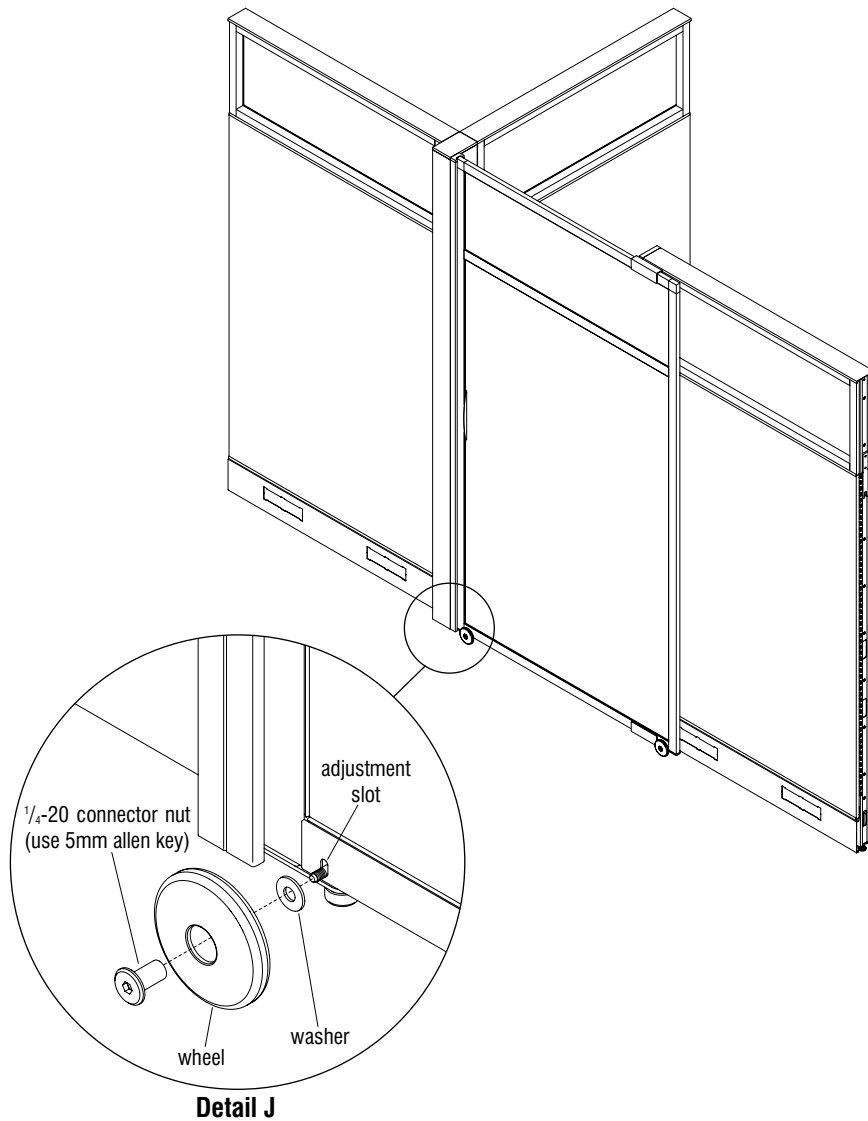

Figure 16

### 90° Corner Jamb Post Installation cont.

6. Check "plumb" of the rolling door to the jamb rail by rolling the door closed, then confirm that the door contacts the jamb rail in a square and even manner. If necessary, adjust the door angle by loosening (**DO NOT REMOVE**) one or both wheels and moving the wheel(s) up or down in the adjustment slot, then re-tightening in the new position. Wheel assembly is shown in detail below for reference (Figure 16, Detail J).

**Tip:** The maximum angle of adjustment is achieved when wheels are adjusted in opposite directions up/down.

# ■ Legion® System Rolling Door - Dead End Jamb Post

Assembly Instructions

## Dead End Jamb Post Installation

**Note:** The dead end jamb post is installed where a rolling door closes into the end of a panel frame at the side, and the panel frame with the jamb forms a 90° intersection (see Figure 20). Refer to instructions at the beginning of this manual (pages 3-8, figures 1-6) for proper installation of the rolling door and components.

1. Position the dead end jamb post to the end of the panel frames so that approximately 1" of the post extends into the walkway. Fasten the jamb post to the panel frame using the 3/8-16 x 1 1/4" hex head bolts and washers from inside the panel. Next install the jamb post top cap to the jamb post (Figure 17).

**Note:** The dead end jamb post is non-handed, and may be oriented on either the right or left side of an opening.

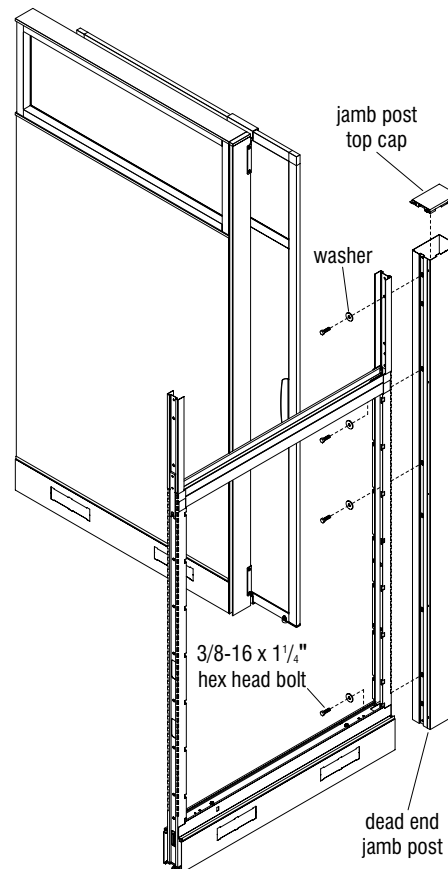

Figure 17



Assemble units as described herein only. To do otherwise may result in instability. All screws, nuts and bolts must be tightened securely and must be checked periodically after assembly. Failure to assemble properly, or to secure parts may result in assembly failure and personal injury.

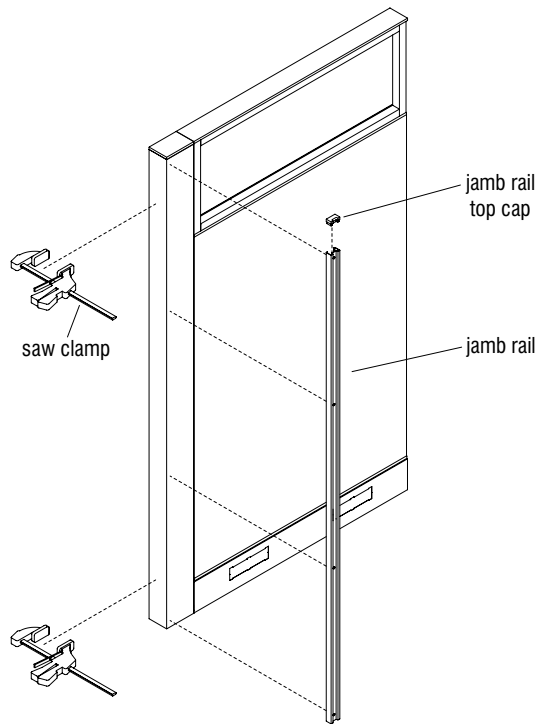

Figure 18

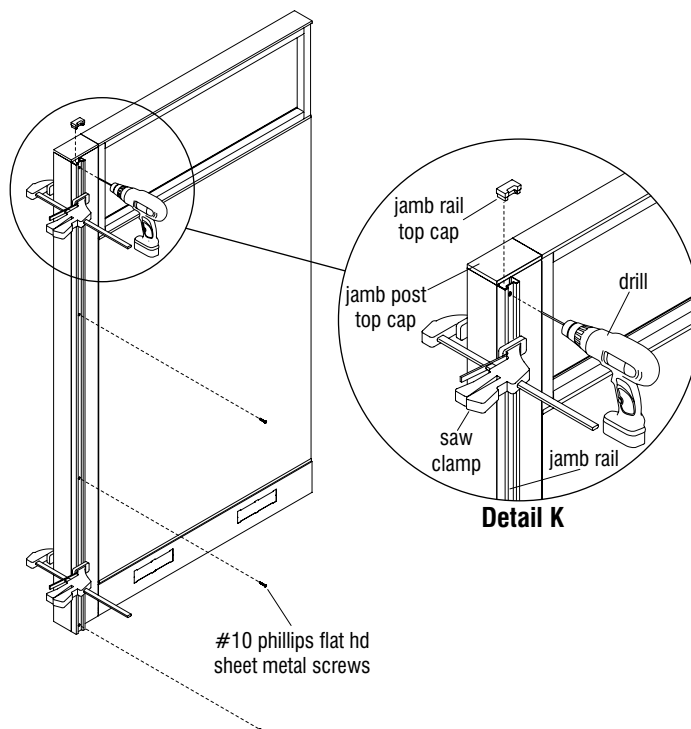

Figure 19

### Dead End Jamb Post Installation cont.

2. Take a jamb rail in hand and install a jamb rail top cap to it. Place the jamb rail with cap against the dead end jamb post where the rolling door will close to it. Use two clamps to position the jamb rail straight and flush with the front edge as illustrated. The jamb rail top cap should also be flush at the top with the jamb post top cap. (Figure 18).
3. While the jamb rail is clamped securely and straight, use a  $\frac{1}{8}$ " drill bit and bore holes through the jamb post using each of the four jamb rail holes as guides for drilling (Figure 19, Detail K).
4. Install four #10 Phillips flat head sheet metal screws to secure the jamb rail to the jamb post. Do not over-tighten screws (Figure 19).

# ■ Legion® System Rolling Door - Dead End Jamb Post

Assembly Instructions

## Dead End Jamb Post Installation cont.

6. Check “plumb” of the rolling door to the dead end jamb rail by rolling the door closed, then confirm that the door contacts the jamb rail in a square and even manner. If necessary, adjust the door angle by loosening (**DO NOT REMOVE**) one or both wheels and moving the wheel(s) up or down in the adjustment slot, then re-tightening in the new position. Wheel assembly is shown in detail below for reference (Figure 20, Detail L).

**Tip:** The maximum angle of adjustment is achieved when wheels are adjusted in opposite directions up/down.

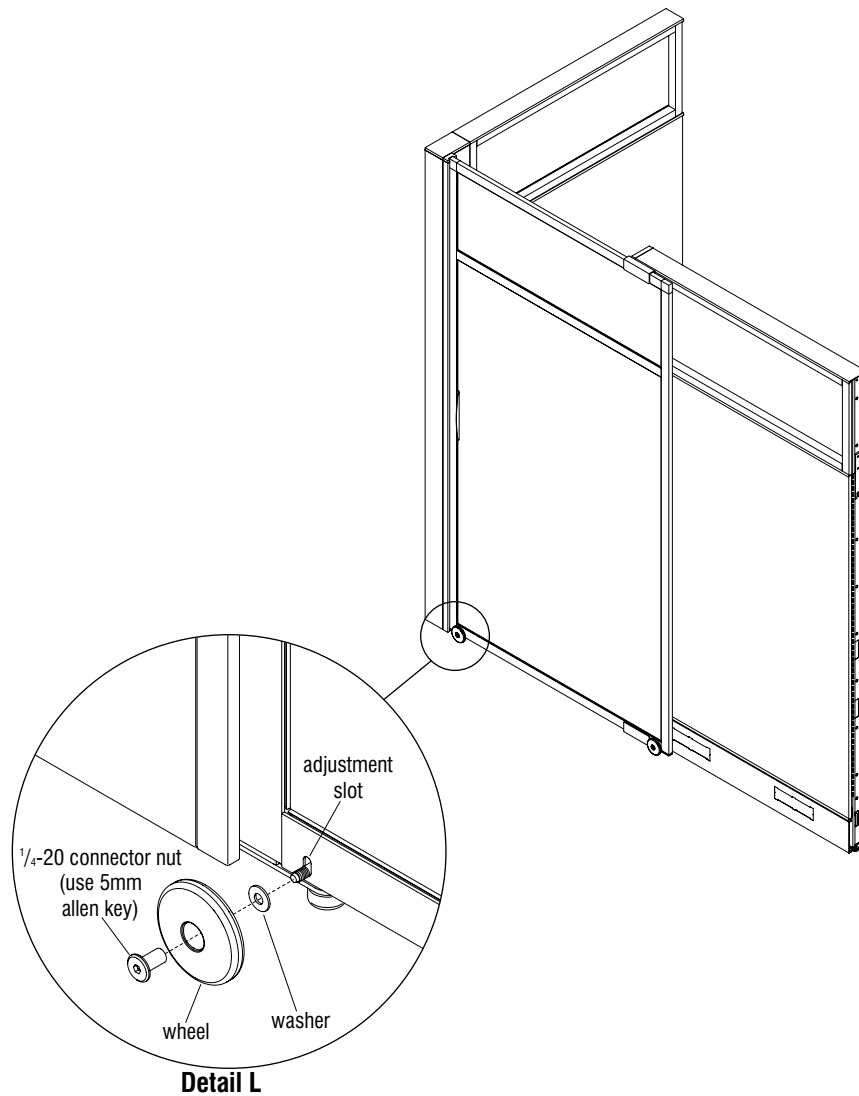

Figure 20



Assemble units as described herein only. To do otherwise may result in instability. All screws, nuts and bolts must be tightened securely and must be checked periodically after assembly. Failure to assemble properly, or to secure parts may result in assembly failure and personal injury.

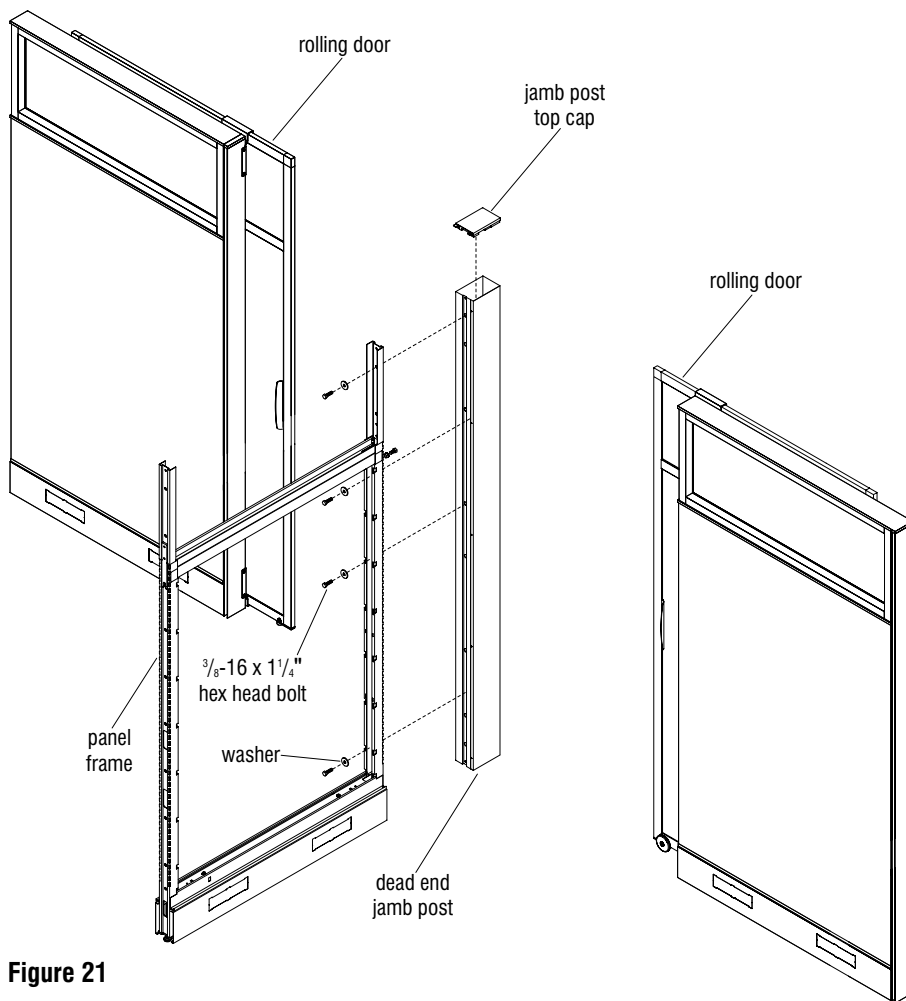

Figure 21

### Double Dead End Jamb Post Installation

**Note:** The double dead end jamb post is installed to the end of a panel frame where a rolling door closes to each side of the dead end jamb post (see Figure 24). Refer to instructions at the beginning of this manual (pages 3-8, figures 1-6) for proper assembly and installation of the rolling door and components.

**Note:** The double dead end model uses the same dead end jamb post as the standard dead end model except two jamb rails are installed, one on each side of the post.

1. Position the dead end jamb post so that approximately 1" of the post extends into the walkway. Fasten the jamb post to the panel frame using the  $\frac{3}{8}$ -16 x  $1\frac{1}{4}$ " hex head bolts and washers from inside the panel. Next install the jamb post top cap to the jamb post (Figure 21).

# ■ Legion® System Rolling Door - Double Dead End Jamb Post

Assembly Instructions

## Double Dead End Jamb Post Installation cont.

2. Take two jamb rails in hand and install a jamb rail top cap to each. Place both jamb rails with cap against the dead end jamb post where the rolling doors will close to them. Use two clamps to position the jamb rail straight and flush with the front edges as illustrated. The jamb rail top caps should both be flush at the top with the jamb post top cap. (Figure 22).
3. While the jamb rails are clamped securely and straight, use a  $\frac{1}{8}$ " drill bit and bore holes through the jamb post using each of the four jamb rail holes at both jamb rails as guides for drilling (Figure 23, Detail M).
4. Install four #10 Phillips flat head sheet metal screws to secure each jamb rail to the jamb post. Do not over-tighten screws (Figure 23).

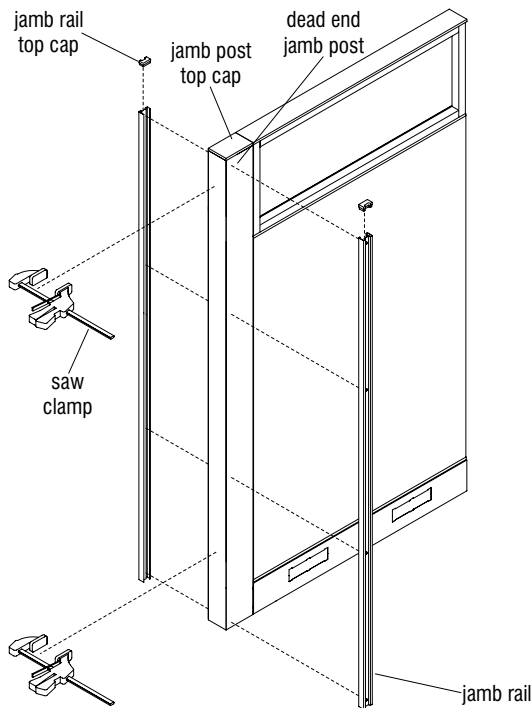

Figure 22

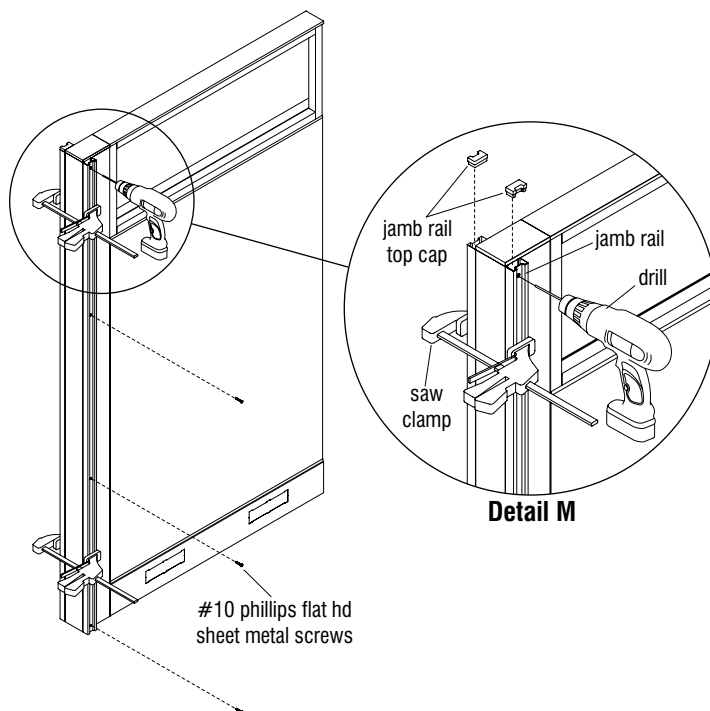

Figure 23



Assemble units as described herein only. To do otherwise may result in instability. All screws, nuts and bolts must be tightened securely and must be checked periodically after assembly. Failure to assemble properly, or to secure parts may result in assembly failure and personal injury.

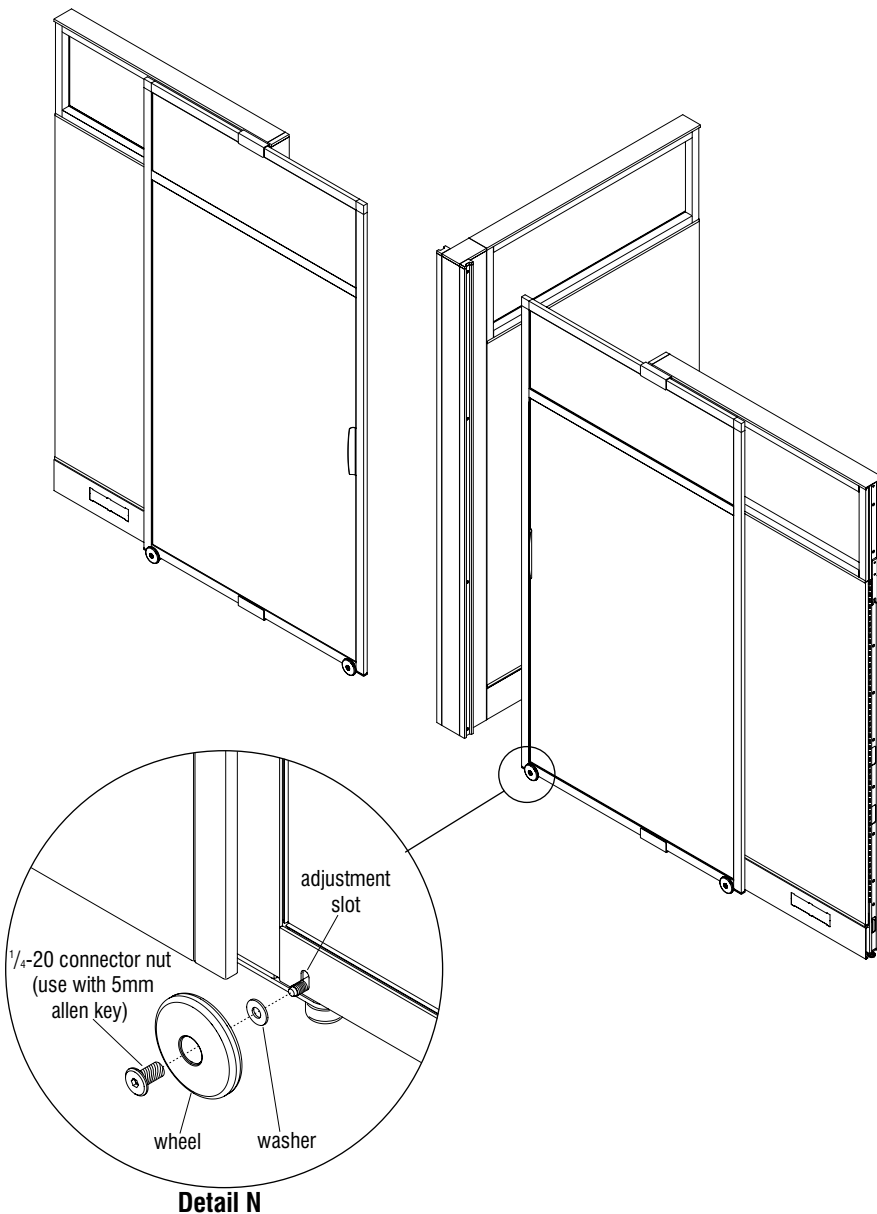

Figure 24

**Double Dead End Jamb Post Installation cont.**

6. Check "plumb" of each door to the jamb rail by rolling the doors closed, then confirm that the doors contact the jamb rail in a square and even manner. If necessary adjust the door angle by loosening one or both wheels and moving the wheels up or down, then re-tightening in the new position. **(Do not remove the wheel)**. Wheel assembly shown in detail below for reference (Figure 24, Detail N).

**Tip:** Maximum angle provided when wheels are adjusted in opposite directions.

# ■ Legion® System Rolling Door - Building Wall Jamb Rail

Assembly Instructions

## Building Wall Jamb Rail Installation

1. Locate the jamb rail to be installed and press a jamb rail top cap into top of jamb rail (Detail 0).

**Note:** Refer to instructions at the beginning of this manual (pages 3-8, figures 1-6) for proper installation of the rolling door and components.

2. Determine the jamb rail center/mounting location by rolling the installed rolling door to the building wall and marking the vertical center of the door on the wall. Also mark the top of the rolling door at the wall, to correctly locate the height of the jamb rail (Figure 25).

**Note:** Building walls are constructed with various materials, so fasteners for the jamb rail are not included. Separate, site specific, customer supplied wall anchors and fasteners must be provided for installation. Drywall will require dry wall anchors which are available in a wide variety of styles.

3. Position the jamb rail against the building wall, plumb and centered to rolling door according to marked locations from step 2. Use a pencil or other device to mark mounting hole locations through jamb rail mounting holes. Drill appropriate diameter holes and install correct wall anchors for site location. Secure jamb rail to customer supplied wall anchors (Figure 25).

4. Check “plumb” of the rolling door to the jamb rail by rolling the door to the jamb rail then confirm that the door contacts it in a square and even manner. If necessary, adjust the door angle by loosening one or both wheels and moving the wheels up or down, then re-tightening in the new position (Figure 23). Do not remove the wheel.

**Tip:** Maximum angle provided when wheels are adjusted in opposite directions.

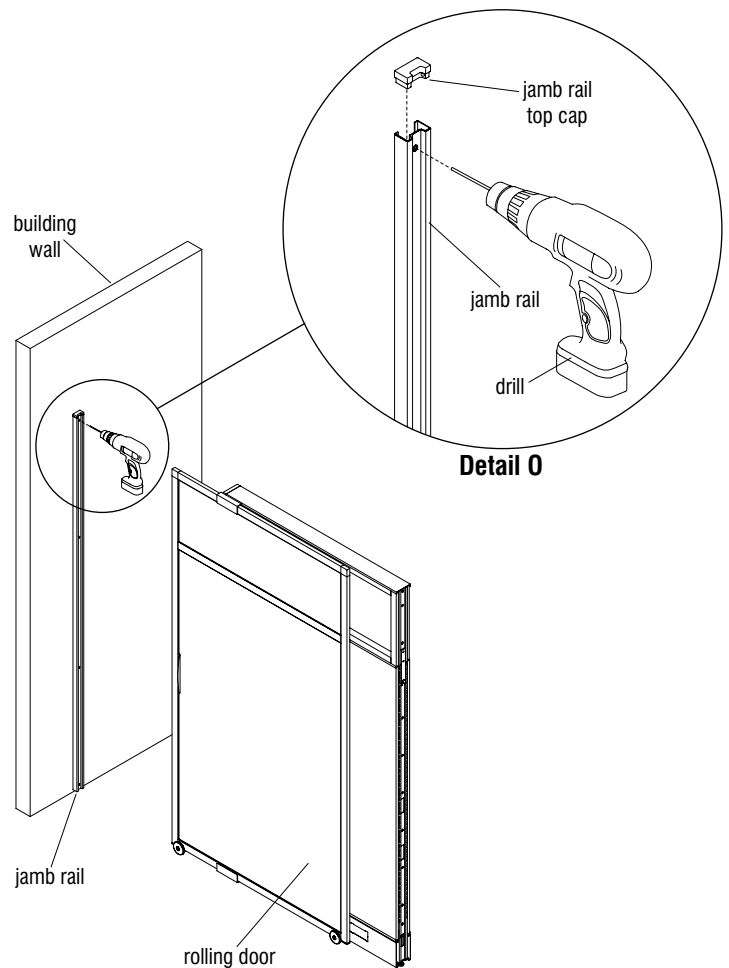
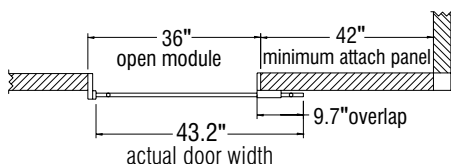

Figure 25





Assemble units as described herein only. To do otherwise may result in instability. All screws, nuts and bolts must be tightened securely and must be checked periodically after assembly. Failure to assemble properly, or to secure parts may result in assembly failure and personal injury.



**closed**  
**Inline (180°) 36" Rolling Door with Closing Jamb**

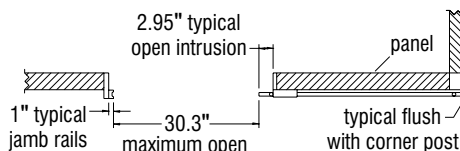

**open**

**Rolling Doors with Closing Jamb Configurations**

Configurations with a closing jamb include a closing post and jamb rail. Five basic models are available as shown below.

- 36" models with typical "closed" and "open" dimensions
- Inline 180°, 90°, Dead End, Double Dead End, Building Wall

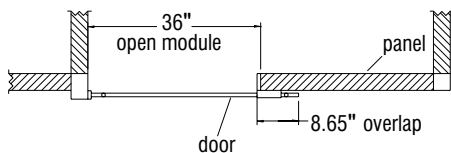

**closed**  
**Corner (90°) 36" Rolling Door with Closing Jamb**

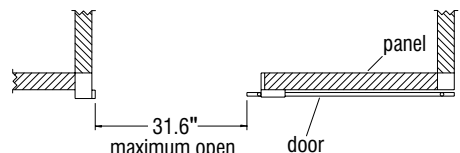

**open**

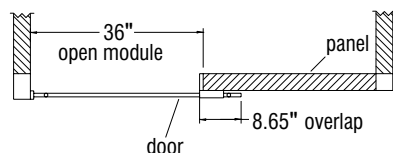

**closed**  
**Dead End 36" Rolling Door with Closing Jamb**

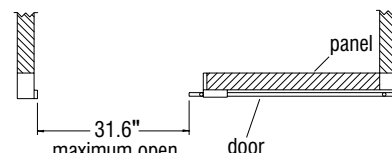

**open**

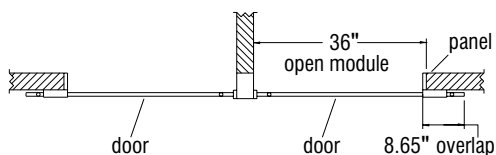

**closed**  
**Double Dead End 36" Rolling Door with Closing Jamb**

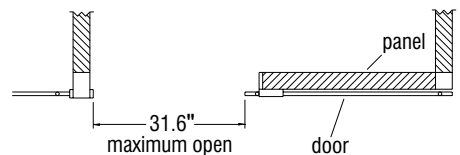

**open**

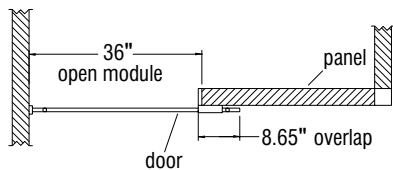

**closed**  
**Building Wall 36" Rolling Door with Closing Jamb**

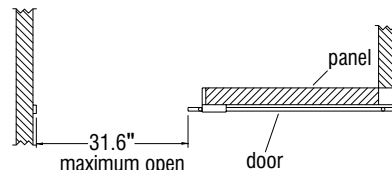

**open**

**Legion® System Rolling Door - Rolling Door Configurations with Closing Jamb**  
 Assembly Instructions

**Rolling Doors with Closing Jamb Configurations cont.**

- 42" models with typical "closed" and "open" dimensions
- 180° Inline, 90°, Dead End, Double Dead End, Building Wall

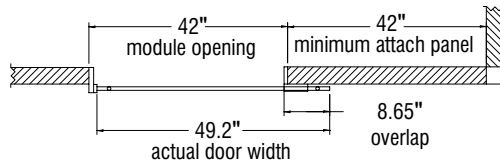

**closed**  
**Inline (180°) 42" Rolling Door with Closing Jamb**

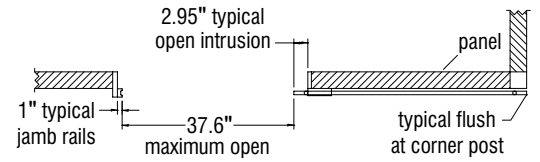

**open**

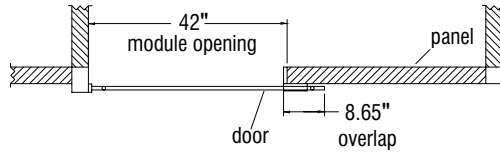

**closed**  
**Corner (90°) 42" Rolling Door with Closing Jamb**

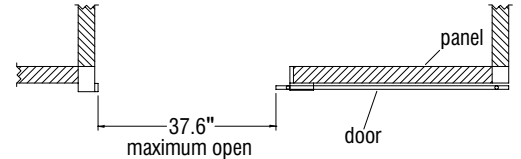

**open**

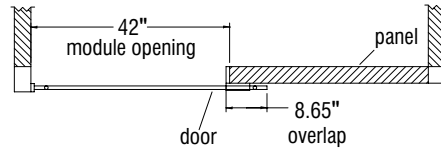

**closed**  
**Dead End 42" Rolling Door with Closing Jamb**

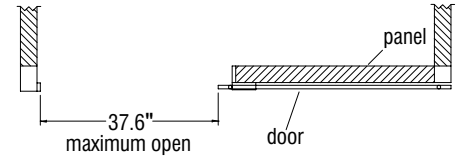

**open**

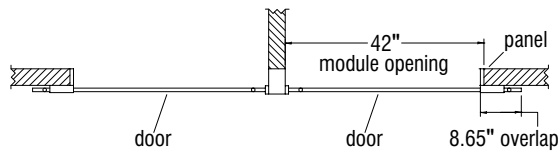

**closed**  
**Double Dead End 42" Rolling Door with Closing Jamb**

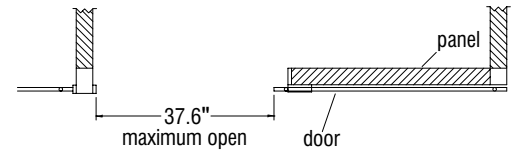

**open**

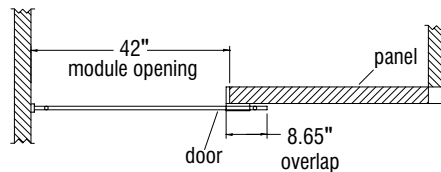

**closed**  
**Building Wall 42" Rolling Door with Closing Jamb**

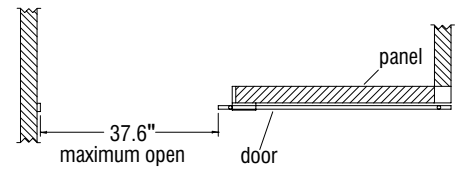

**open**



**CAUTION**

Assemble units as described herein only. To do otherwise may result in instability. All screws, nuts and bolts must be tightened securely and must be checked periodically after assembly. Failure to assemble properly, or to secure parts may result in assembly failure and personal injury.

**Rolling Door Threshold Accessory Installation**

**Note:** The position and installation of the door threshold is the same for doors with jambs and without Jambs. The following instructions are the same for both.

1. If a rolling door has been installed, the door must be removed first. At the top door guide bracket, remove the two #10-16 x 3/4" Tek screws installed into the end-of-run attaching trim at the end of the panel (Figure 2, page 4). Next, lift up on the rolling door to push up the upper door guide bracket enough to allow the rolling door to be removed. Tip the bottom of the rolling door out and remove top of door from the top tour guide bracket to remove rolling door.
2. Install threshold end caps to the threshold by tapping them in with a rubber mallet. Ends caps are unpainted aluminum as standard, even when used with black thresholds (Detail A).

3. Determine the type of adhesive strip to use according to floor type. Double back foam tape pads is typically used on hard floors and carpet. Adhesive back hook pads are used on soft carpet.

4. Apply one strip onto the bottom of the threshold at both ends. Equally space the remaining two strips to the underside (Figure 1, Detail A).

**Note:** Do not remove the adhesive backing which faces the floor-side at this time.

5. Position the end of the threshold near the center of the jamb post, roughly 1" from the edge of the trim. Lay the threshold parallel to the panel, and tuck it under the jamb post as illustrated.

**Note:** Only one configuration is shown as reference. The threshold position is the same for all panel configurations. Follow space-planning layout and see typical plan views on the next page.

6. Re-install door for position only, and loosely move the upper door guide back down so the door can be held in place for testing. Next, roll the door and move the threshold so that the rolling door wheels are centered in the threshold groove, so the door rolls freely and does not contact or rub on the rolling door panel. Mark the threshold location, then remove the door for final threshold adhesion process (Detail C).

7. Peel the four adhesive strip backers off and re-position the threshold according to alignment marks on floor. Press down on the threshold to make sure it is fully adhered. Re-install the rolling door.

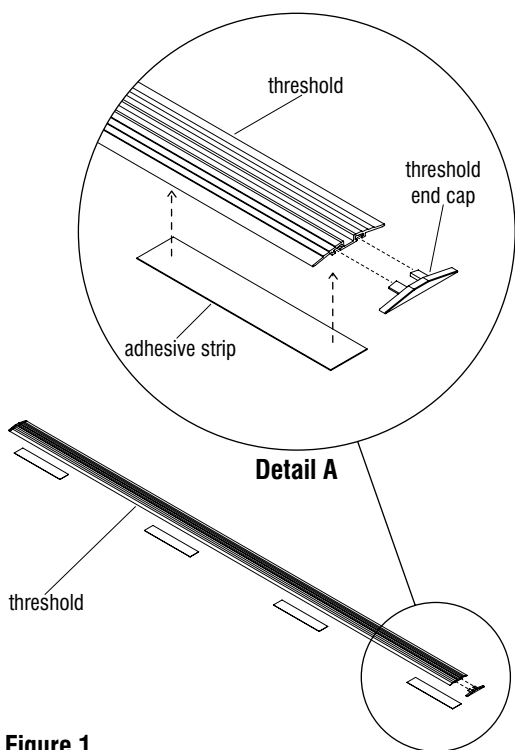

**Figure 1**

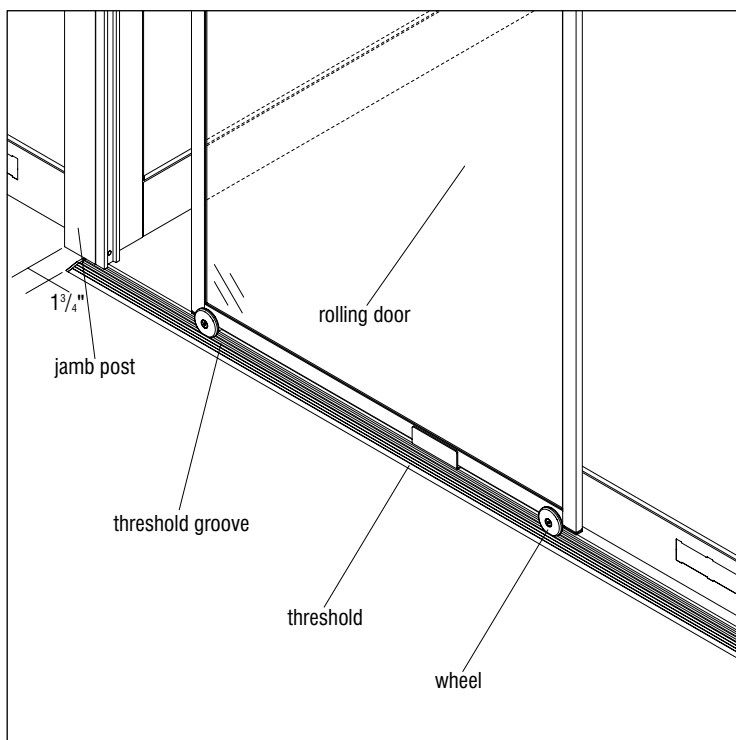

**Detail B**

■ Legion® System Rolling Door - Threshold Typical Configurations  
 Assembly Instructions

**Threshold Typical Configurations**

Dimensions for threshold with jamb are typical for each configuration.

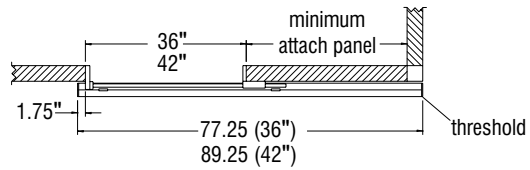

**Threshold with Inline (180°)**

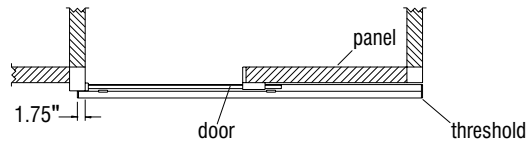

**Threshold with Corner (90°)**

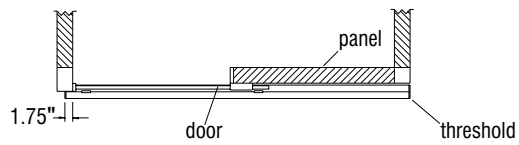

**Threshold with Dead End**

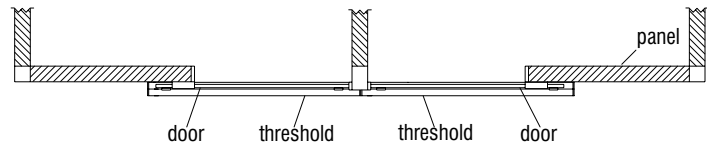

**Threshold with Double Dead End**  
 (two thresholds are used)

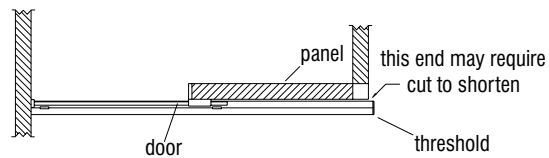

**Threshold with Building Wall**



Assemble units as described herein only. To do otherwise may result in instability. All screws, nuts and bolts must be tightened securely and must be checked periodically after assembly. Failure to assemble properly, or to secure parts may result in assembly failure and personal injury.

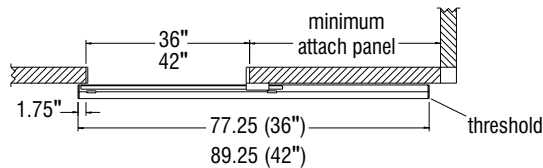

**Threshold with No Jamb Inline (180°)**

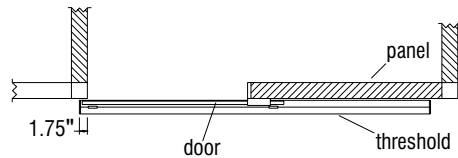

**Threshold with No Jamb Corner (90°)**

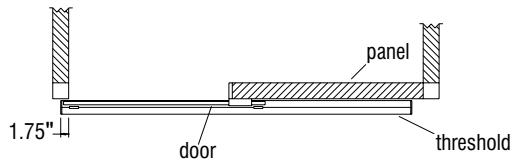

**Threshold with No Jamb Dead End**

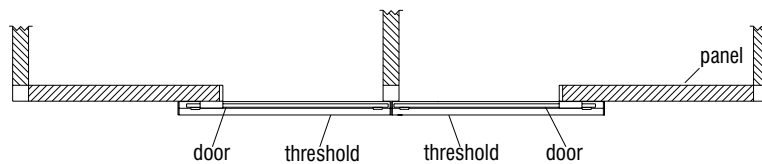

**Threshold with No Jamb Double Dead End**  
 (two thresholds are used)

**Threshold Typical Configurations cont.**

Dimensions for threshold with no jamb are typical for each configuration.

**Threshold Continuous**

Continuous thresholds are 96" long and are designed to run end to end, typically on a hallway run of work station door openings. End caps are only necessary at the ends.

■ Legion® System Rolling Door  
Assembly Instructions



Assemble units as described herein only. To do otherwise may result in instability. All screws, nuts and bolts must be tightened securely and must be checked periodically after assembly. Failure to assemble properly, or to secure parts may result in assembly failure and personal injury.

