

POWERWORKS®

PANEL SYSTEM

installation instructions



Table of Contents

Required Tools	2
Overview	3
Frame Assembly	4
Enhanced Horizontals Rails	10
Tile Hook Installation	13
Door Installation	14
Off-Module Panel Installation	17
Overhead Cabinet Assembly	19
Worksurface Installation	22
Worksurface Bracket Guidelines	24
Electrical Installation	26
Receptacle/Bezel Installation	29
Base Trim Installation	31
Power Infeed Installation	33
Data Cable Management	36
Tile Installation	43
Trim Installation	46
Reconfiguration	50
Specification Guidelines	52
810 Universal Electrical	54

Required Tools

Required Tools for Assembly

The following tools are required to assemble panels:

- Dead blow mallet
(soft rubber mallet filled with shock absorbing material such as sand or lead shot)
- 3/8" large, flat blade screwdriver
- T-40 Torx wrench
- 9/16" open end wrench
- #3 Phillips head screwdriver
- Diagonal pliers
- Utility knife
- Hack saw
- Miter box

Scope of Manual

This installation manual is organized in the same order as a typical installation would be conducted - starting with frame members and ending with connection of electrical infeeds.

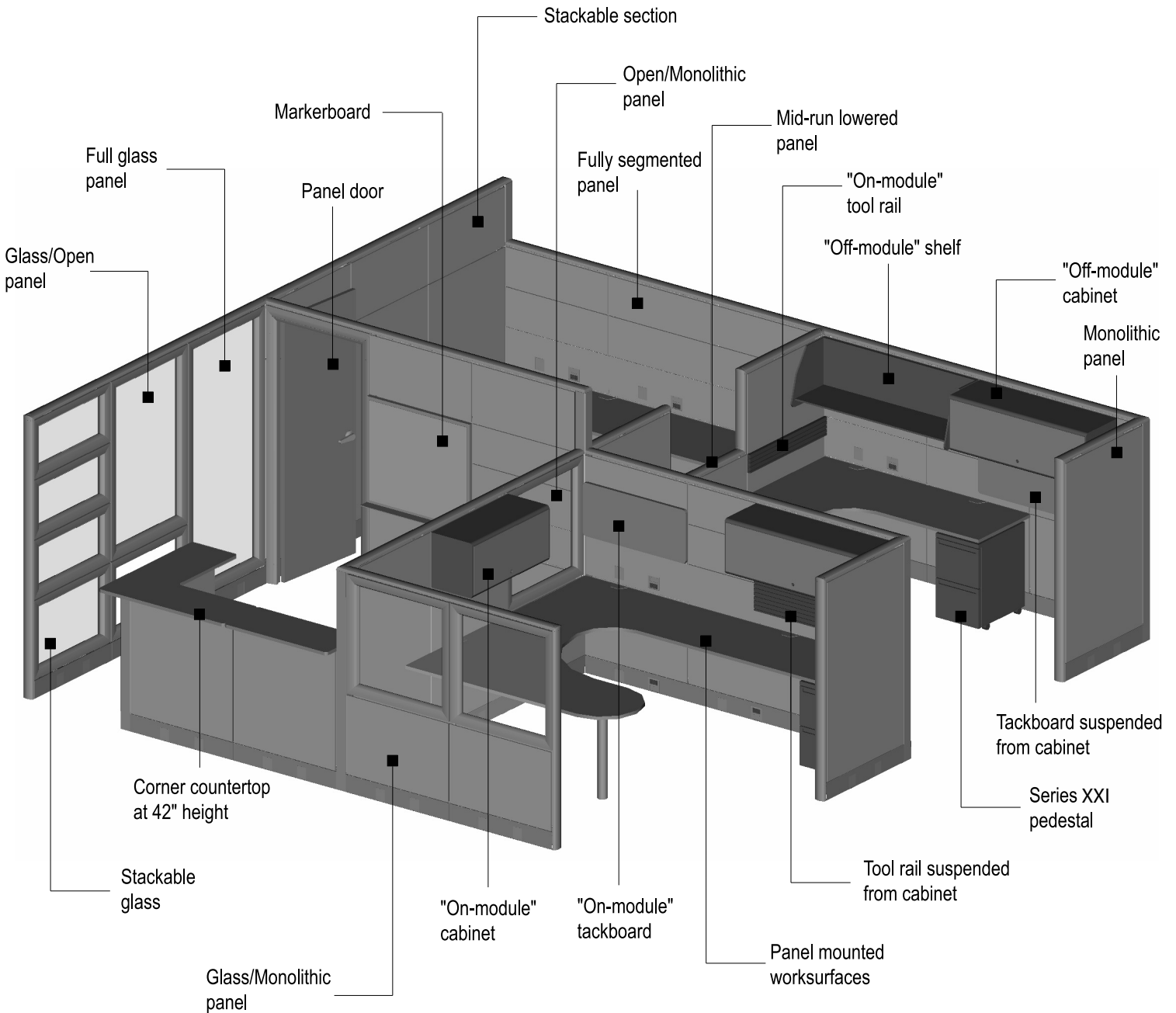

Frame Assembly

Overview

PowerWorks Panel System uses four (4) basic parts to build the framework for the panels:

- full (width) vertical post
- half (width) vertical post
- horizontal rail
- connector block

Full vertical posts are used at straight in-line conditions and at end-of-runs. Half vertical posts are used along with the 90° connector block to make 90°, 3-way and 4-way panel intersections.

Note: Half vertical posts are approximately one half the width of a full post.

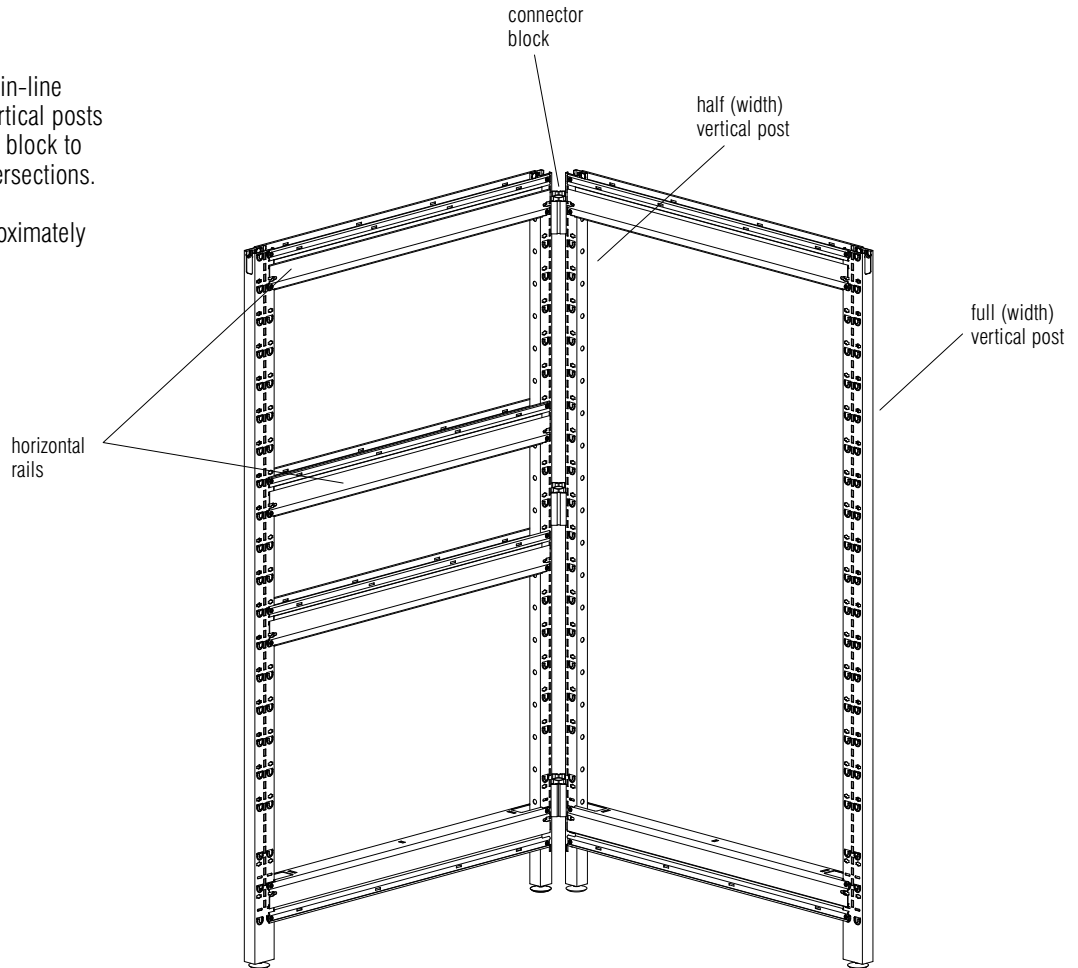

Top views of four possible combinations of connector blocks and half vertical posts.

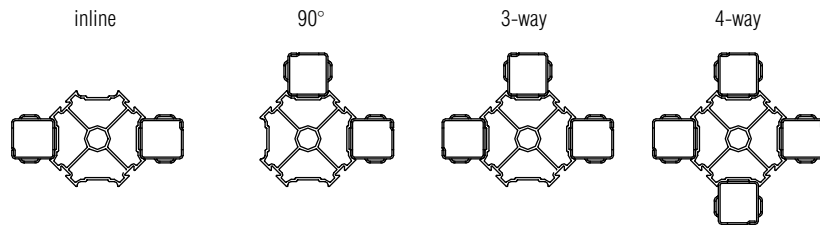

Possible intersection combinations

Highest Point of Floor

Prior to erecting the system, locate the highest point of the floor and position the first corner of the workstation at that point.

Assembling Intersections

Note: Refer to the space plan to determine the necessary intersection specifications.

1. Assemble intersections by bolting two, three, or four half posts together using a connector block and shoulder bolts with a T-40 TORX wrench. **Figure 1.** Refer to page 7 for the correct number of connector blocks per intersection.

Note: The plastic inserts at the bottom of the vertical posts must be oriented such that the recessed cut out is positioned under the slots.

Detail A.

Note: All half posts get one connector block in the lowest hole and one connector block in the highest hole, with taller posts requiring additional connectors. See Planning Guide for more detailed information. Position connector blocks at heights that avoid obstructing power and data cabling. Refer to the space plan for power and data locations.

Note: All bolts need to be torqued to 50 in./lbs. to 75 in./lbs. Failure to tighten to proper settings could cause unstable panel runs.

Assembling Intersections cont. on page 6.

Installing Light Block Tubes

In all intersection conditions, light block tubes are required. Variable height intersections require a light block tube to the lowest panel height.

1. Slide the light block tube through the holes in the center of connector block. **Figure 2.**

Note: If necessary, the tube may be collapsed and bent where there is not enough ceiling clearance to slide the tube vertically into position.

Hint: The light block tube is held in place by friction. If the tube does not stay positioned, use a wrap of black electricians' tape around the tube above one of the connector blocks.

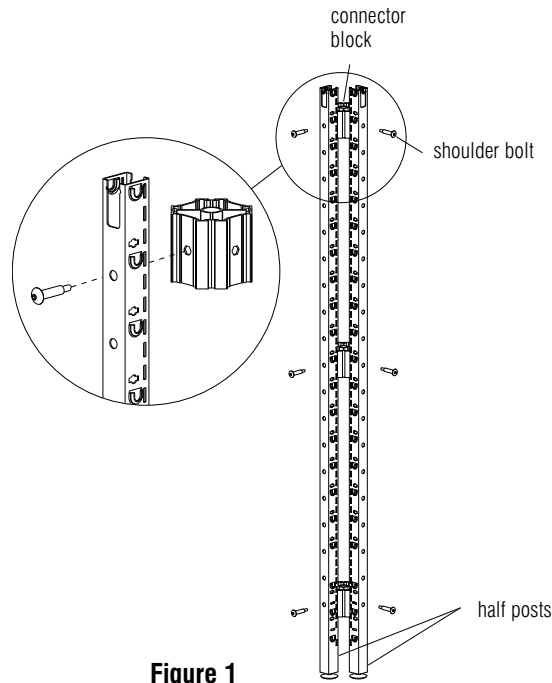
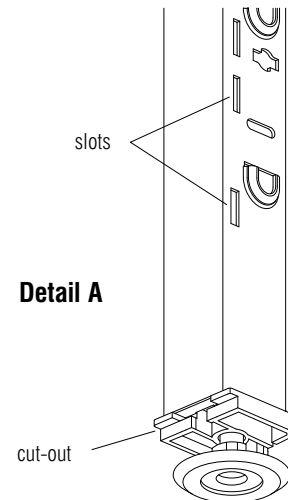

Figure 1



Detail A

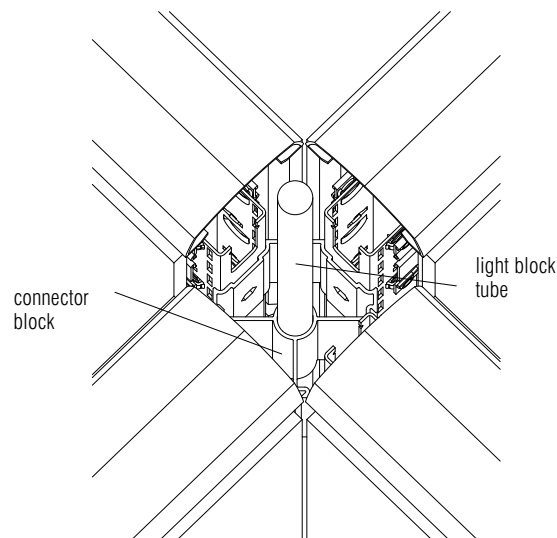

Figure 2

Frame Assembly

Assembling Intersections (continued)

- Install height change connector block (if required) to the frame using shoulder bolts with a T-40 TORX wrench. **Figure 3.** Refer to the table on next page for the correct number of connector blocks, and **Detail B** below for correct bolt locations.

Note: Height change connector blocks have a wire management channel that allows cables to be routed between two different height panels. **Detail C.**

Note: Face the opening of all height change connector blocks toward the shortest panel to allow for lay-in wire management. **Detail D.**

Note: All bolts need to be torqued to 50 in./lbs. to 75 in./lbs. Failure to tighten to proper settings could cause unstable panel runs.

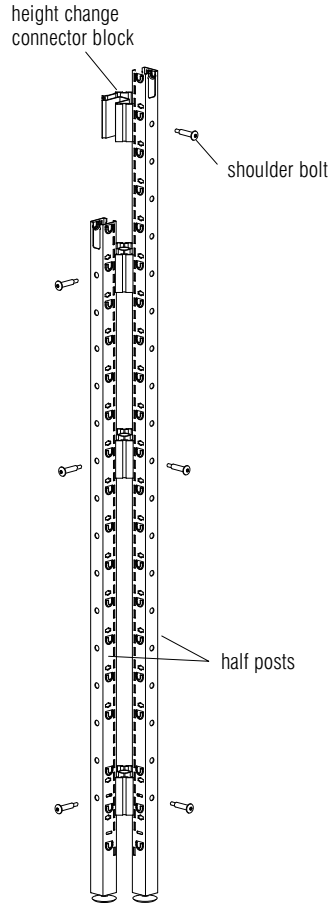
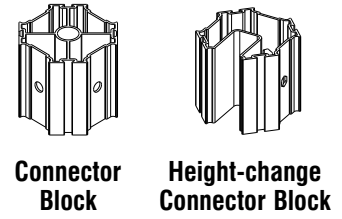
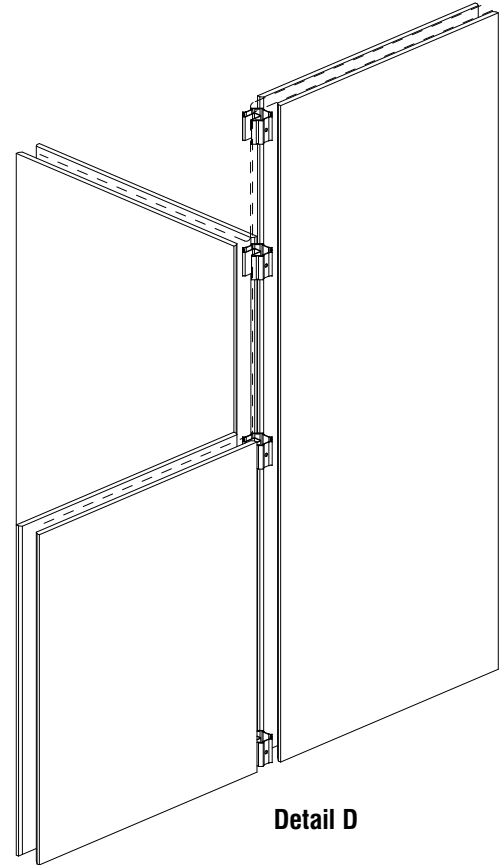

Figure 3



Detail C



Detail D

Use this section for
72-84 intersections

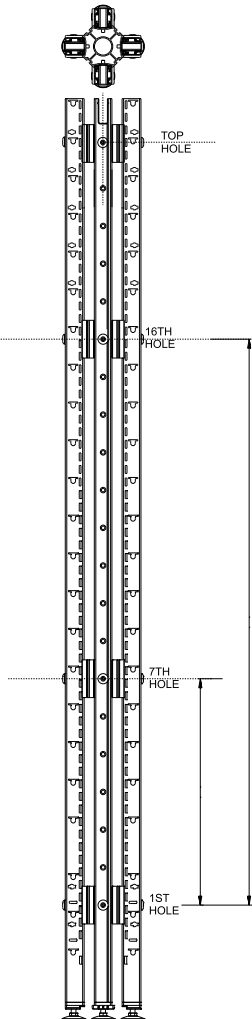

Use this section for
60-66 intersections

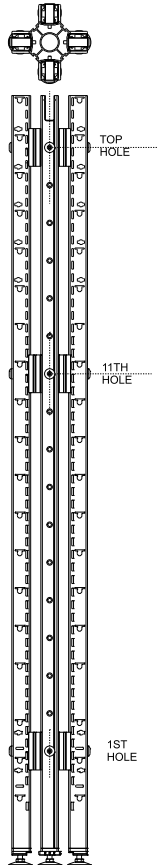

Use this section for
42-54 intersections

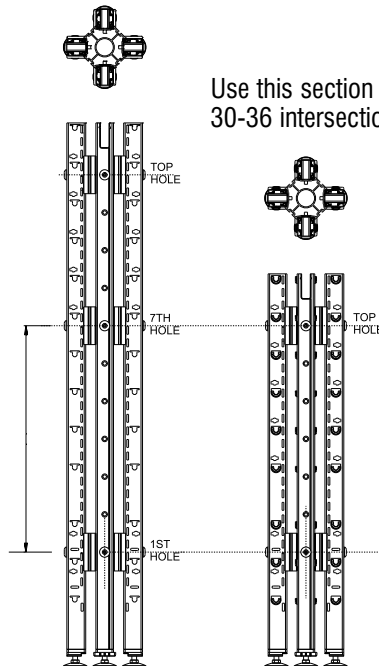

Use this section for
30-36 intersections

Detail B

Rules for Building Intersections

1. Determine quantity of connector blocks by referring to Number of Height-Change Connectors chart.
2. Determine quantity of connector blocks by identifying the shortest panel in your intersection. Refer to corresponding chart.
3. Determine quantity of height-change connector blocks by subtracting heights of the two shortest panels. Refer to the chart for order quantity. If your intersection includes more than two different heights, repeat this process for all heights.

Hint: Start with shortest panel. Use height difference between shortest and next tallest, etc.

Sample

You Need (Refer to **Figure 4**)

Shortest panel
30" = 2 connector blocks

Second shortest panel
54"-30" = 24" or 2 height change connectors

Third shortest panel
66"-54" = 12" or 1 height change connectors

Tallest panel
84"-66" = 18" or 2 height change connectors

TOTAL 2 connector blocks
5 height change connector blocks

Number of Height-Change Connectors

Dimension*	# of Height Change Connector Blocks
6"	1
12"	1
18"	2
24"	2
30"	2
36"	2
42"	3
48"	3
54"	3
60"	3
66"	3
72"	4
78"	4
84"	4

Hint: Dimension refers to the height of a post for same-height applications or the height difference between panels in height-change applications.

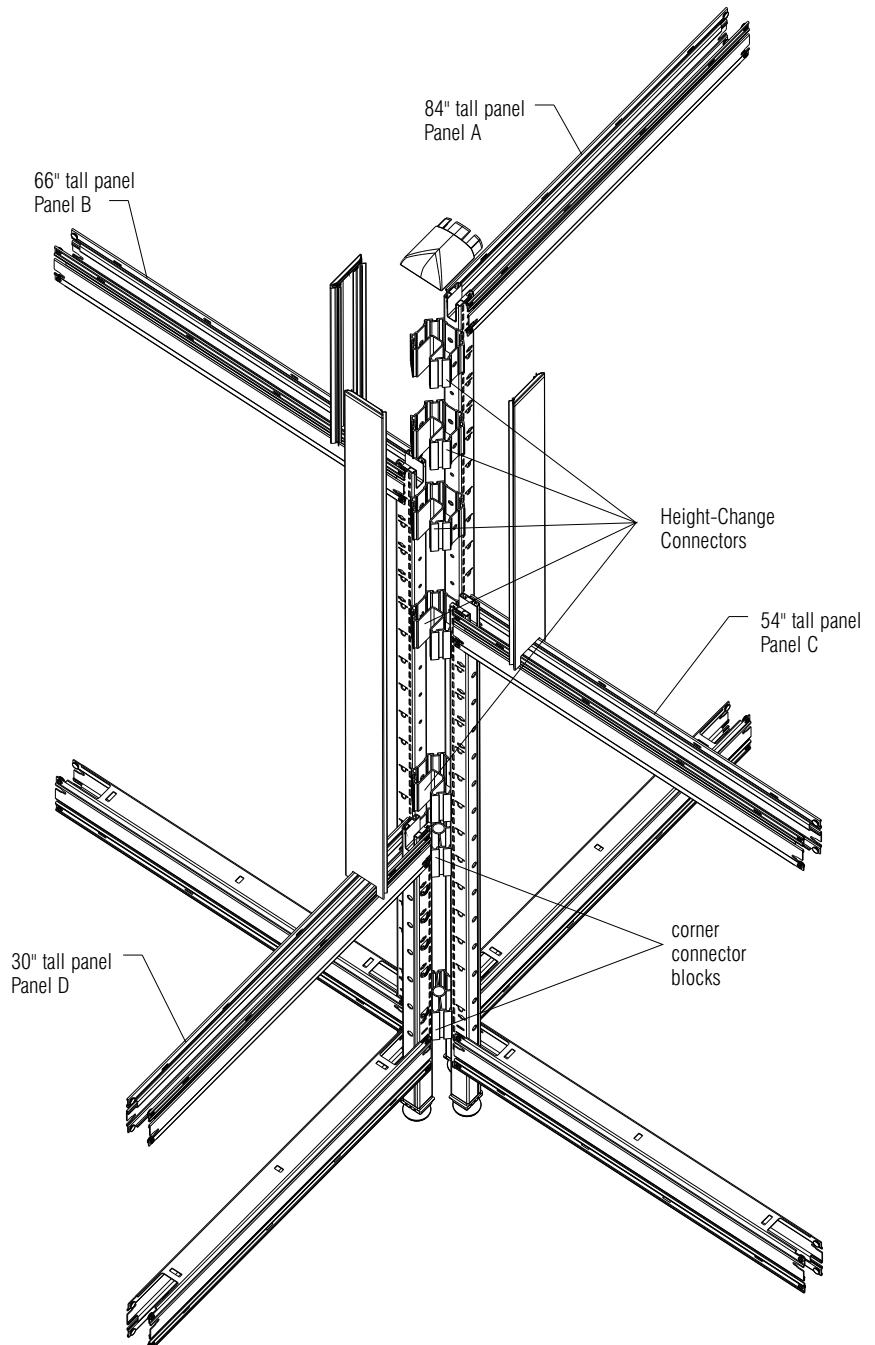

Figure 4

Frame Assembly

Attaching Horizontals To Verticals

Horizontals are used at the top and bottom of a panel to space the vertical posts apart the appropriate distance for the panel width you are building. One rail is used at the top of the panel with the opening facing upward and one rail is used at the bottom facing downward. Panels that are made up of more than one tile also use horizontals at intermediate heights (with the opening facing up).

Note: Refer to the space plan and start with a panel corner intersection building out in two directions so the panel frame is able to stand on its own.

1. Slide a horizontal into the top of a vertical half post with the rivets above the pocket on the post. Making sure all four rivets are lined up with the corresponding embosses, tap the horizontal into place with a dead-blow style mallet. **Figure 5.**
2. Referring again to the space plan, position the appropriate vertical post (full or half post) relative to the horizontals and tap the horizontals into place. **Figure 6.**
3. Repeat the above instructions, building out in a direction perpendicular to the first horizontals from the corner post. When this step is completed you should have a partially assembled 90° corner that can support itself. **Figure 7.**

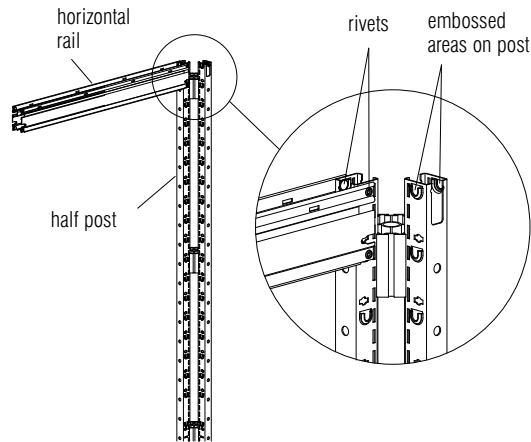

Figure 5

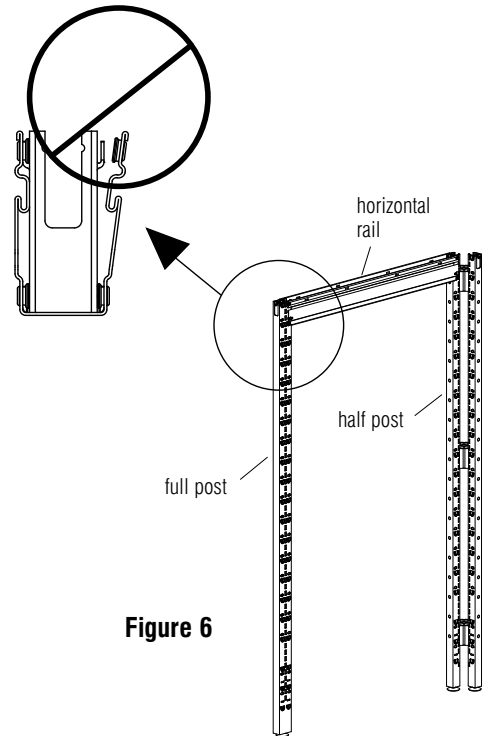

Figure 6

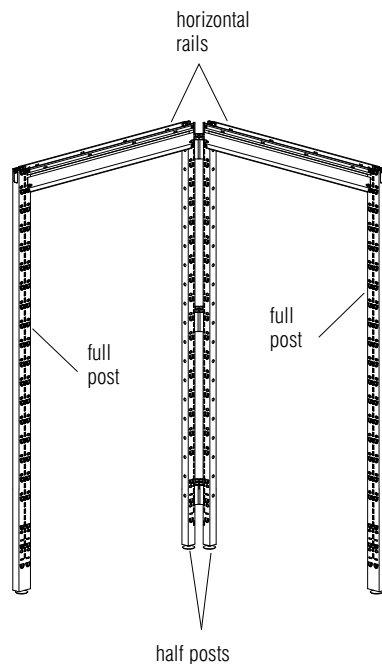

Figure 7

Frame Assembly

4. Position the lower horizontals relative to the lowest set of pockets on the vertical posts with the *opening facing downward* and tap into place with a dead-blow style mallet. Continue to add horizontals as required by the style of panel. **Figure 8.**

Remember, *only the bottom horizontal rails are installed with the opening facing downward.* All other rails openings should face upward.

Warning: Use care when tapping the horizontals in place to ensure that all rivets are sliding into the embossed areas of the post. Failure to engage all rivets into the post will compromise the strength of the frame and could possibly result in product failure.

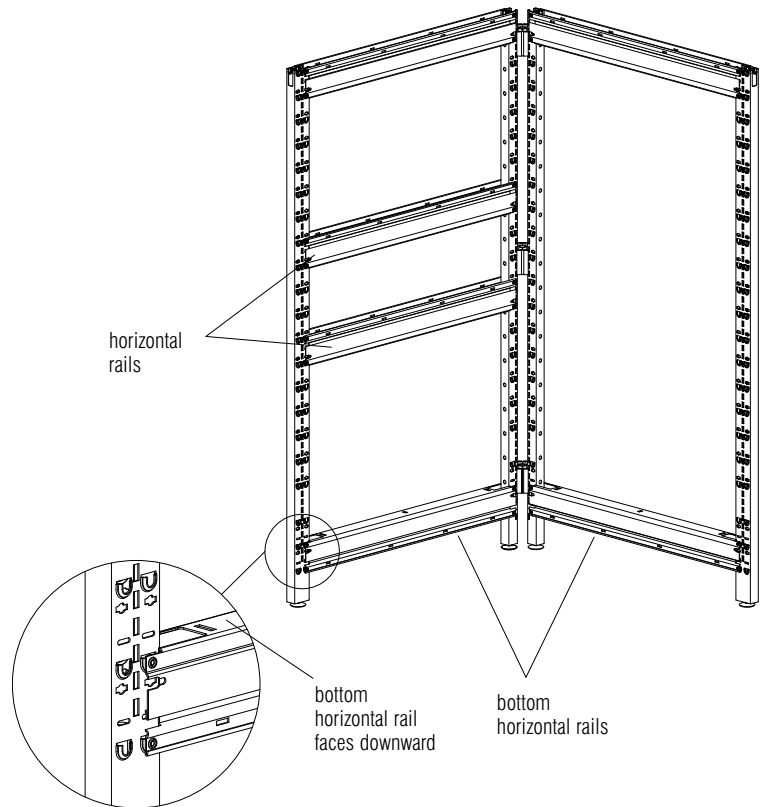
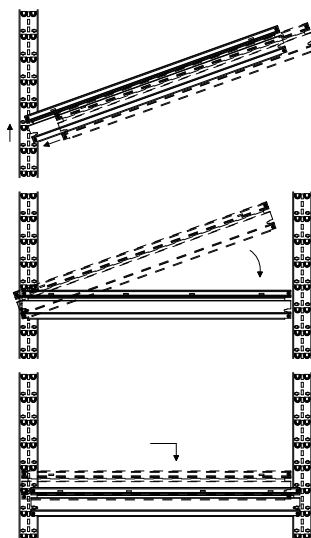
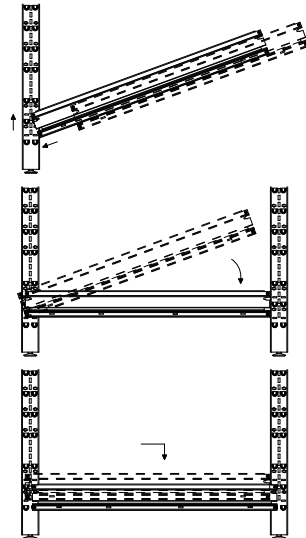

Figure 8

Assembly of Intermediate Horizontals



Assembly of Bottom Horizontals



Enhanced Horizontal Rails

Recognizing Enhanced Horizontal Rails

Each Enhanced Horizontal Rail can be identified by the unique labels that appear on both sides of the horizontal rail. **Figures 9 and 10.**

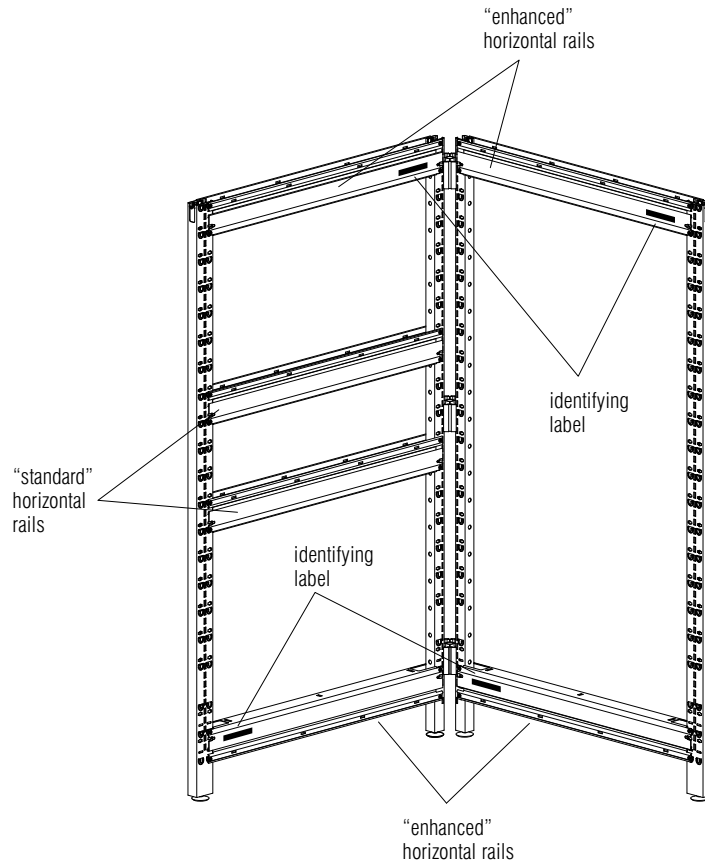

Figure 9

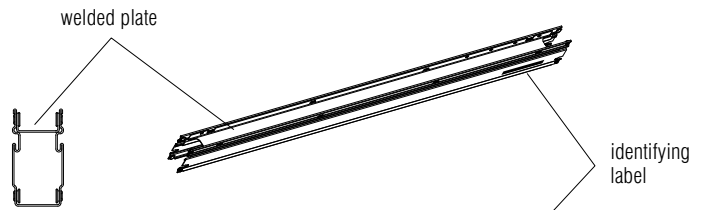

Figure 10

ENHANCED HORIZONTAL

To be used at top and bottom of selected panels.
Refer to space plan to identify correct panels.

Enhanced Horizontal Rails

Attaching Enhanced Horizontals To Verticals

Enhanced Horizontals are used at the top and bottom of a panel to space the vertical posts apart the appropriate distance for the panel width you are building. One rail is used at the top of the panel with the opening facing upward and one rail is used at the bottom facing downward. Panels that are made up of more than one tile use additional standard construction horizontals at intermediate heights (with the opening facing up).

Note: Refer to the space plan to determine which panels receive enhanced horizontals.

1. Slide an enhanced horizontal into the top of a vertical half post with the rivets above the embossed area on the post. Making sure all four rivets are lined up with the corresponding embosses, tap the horizontal into place with a dead-blow style mallet. **Figure 11.**
2. Referring again to the space plan, position the appropriate vertical post (full or half post) relative to the horizontals and tap the horizontals into place. **Figure 12.**
3. Repeat the above instructions, building out in a direction perpendicular to the first horizontals from the corner post. When this step is completed you should have a partially assembled 90° corner that can support itself. **Figure 13.**

Caution: Assemble units as described herein only. To do otherwise may result in instability. All screws, nuts and bolts must be tightened securely and must be checked periodically after assembly. Failure to assemble properly, or to secure parts may result in assembly failure and injury.

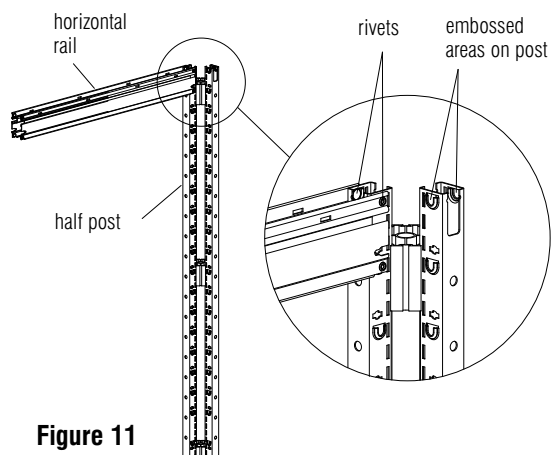

Figure 11

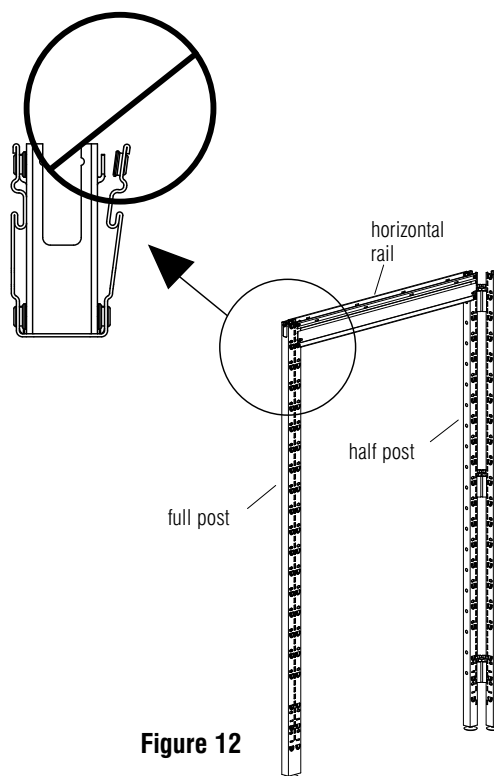

Figure 12

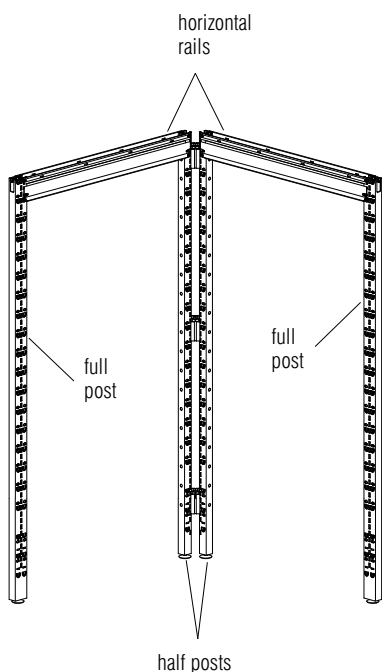

Figure 13

Enhanced Horizontal Rails

Attaching Enhanced Horizontals To Verticals (continued)

- Position the lower enhanced horizontals relative to the lowest set of embossed areas on the vertical posts with the *opening downward* and tap into place with a dead-blow style mallet. Continue to add standard horizontals as required by the style of panel.

Figure 14.

Remember, *only the bottom horizontal rails are installed with the opening facing downward*. All other rails openings should face upward.

Warning: Use care when tapping the horizontals in place to ensure that all rivets are sliding into the embossed areas of the post. Failure to engage all rivets into the post will compromise the strength of the frame and could possibly result in product failure.

Caution: Assemble units as described herein only. To do otherwise may result in instability. All screws, nuts and bolts must be tightened securely and must be checked periodically after assembly. Failure to assemble properly, or to secure parts may result in assembly failure and injury.

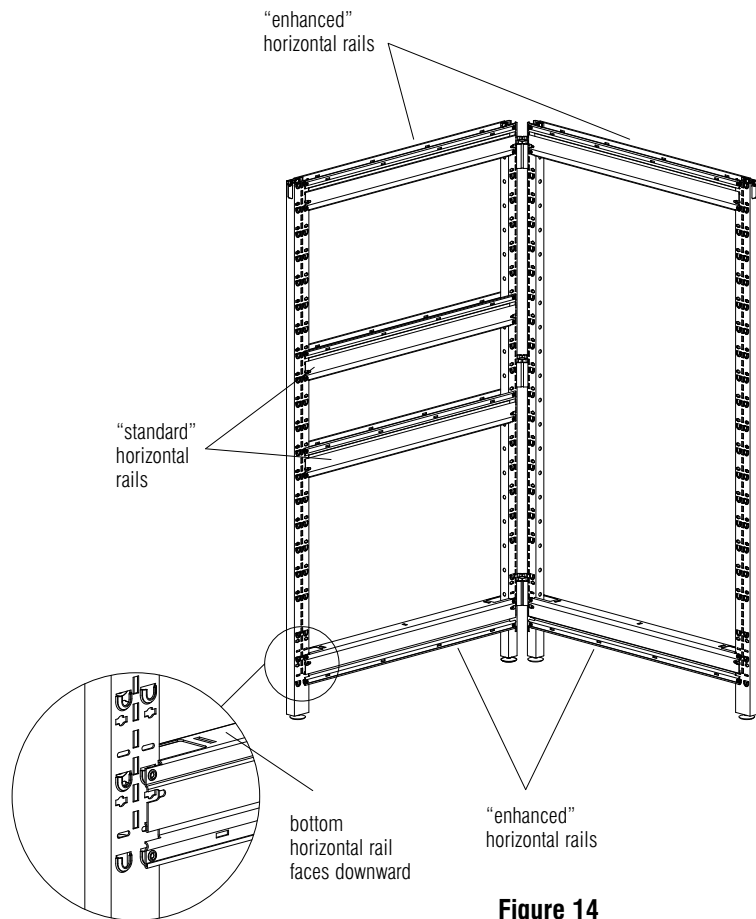
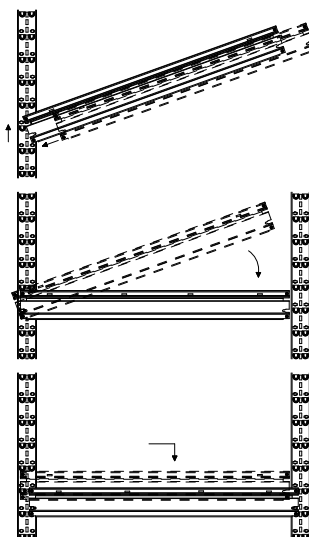
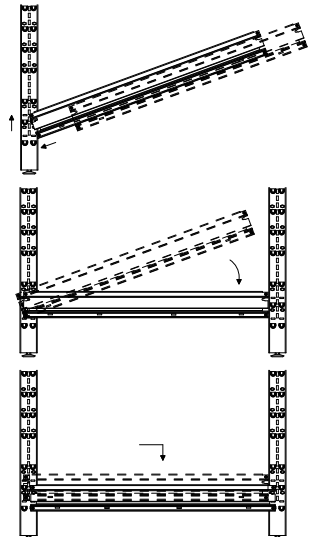

Figure 14

Assembly of Intermediate Horizontals



Assembly of Bottom Horizontals



Tile Hook Installation

Installing Tile Hooks

Tile hooks are used to lock the horizontal rail in place relative to the vertical post and provide a mounting location for the tiles. Four hooks need to be installed for every acoustical and raceway tile.

Note: Be sure the frame has been correctly installed and aligned.

1. Insert tile hooks through the cutout in the end of the horizontal and into the cutout in the vertical with the top of the hook pointing to the left (rounded side of hook faces up). Push the end of each hook through the cut-out, then rotate the hook one-quarter turn to the right so the top of the hook is pointing upward.

Figure 15.

Hint: If the tile hook does not turn properly, the horizontal has not been installed properly. Check to be sure the horizontal rivets are fully seated into the vertical post and that none of the rivets are outside of the embosses. Tile hook should be installed at horizontal connections prior to moving to the next panel section.

When all of the hooks are properly installed, there should be four hooks for each tile you are going to hang on the panel.

Note: On segmented tile panels, hooks are inserted in the cut-outs in the verticals just above the intermediate horizontals as well as through the cut-outs in the horizontal rails. See the diagram on the right.

Leveling

1. After building the first corner, level the panel frames by turning the post glides the appropriate direction with a 9/16" open end wrench. **Figure 16.**

Note: Glides can be adjusted by hand or by using a 9/16" open end wrench.

2. Continue building panels in this manner described in **Attaching Horizontals To Verticals on page 8** until the frames are complete, leveling each panel as it is constructed.

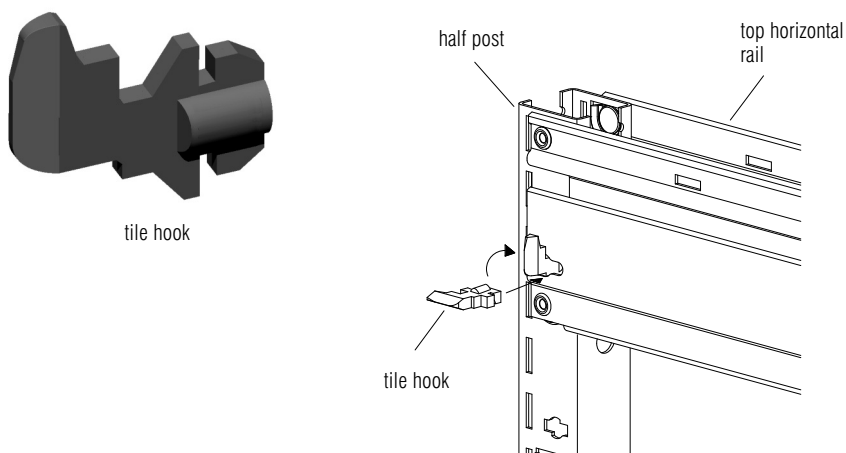

Figure 15

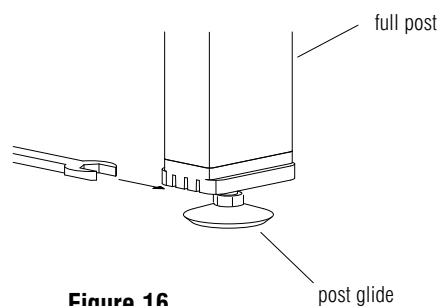
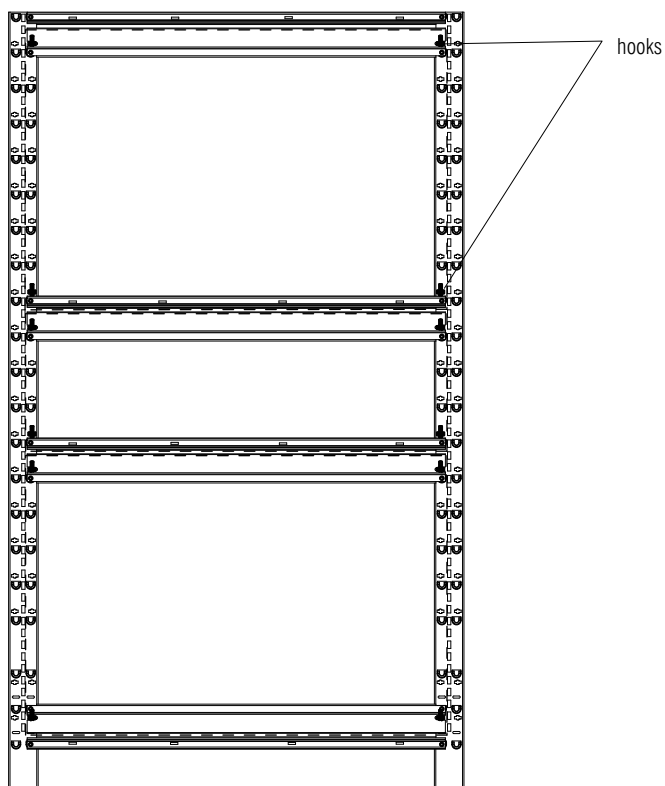

Figure 16

Door Installation

Note: These Installation Instructions are for jambs with and without a door (part numbers PDRR42, PDRL42 and PCOT42). Door jambs attach to 84" full and half vertical posts only. When a door is used in the jamb, it is recommended that the hinge side of the jamb be installed to a 90° corner, 3-way, 4-way or wall mount condition for stability.

Note: The illustrations in this document are for a 42" right hand door (part number PDRR42).

42" door yields actual door width opening of 36" and meets ADA requirements.

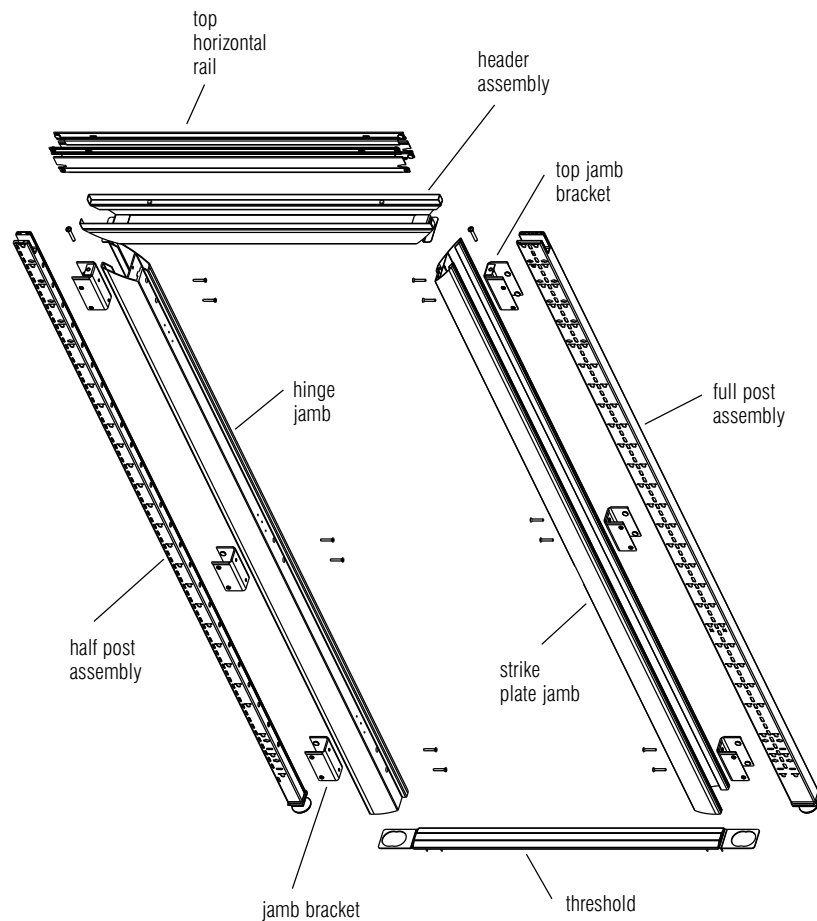
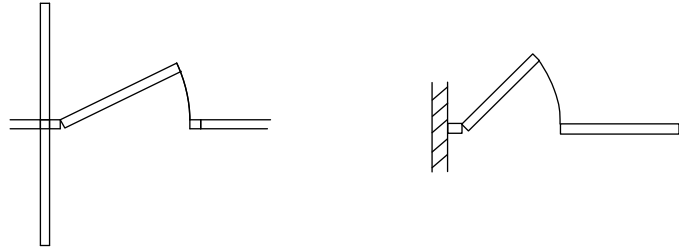

Door Installation

1. When installing panel framework, temporarily install a horizontal rail that corresponds to the doorway opening width of 42" at waist height to ensure correct spacing for doorway. **Figure 17.**
2. If threshold is used, install threshold under vertical post glides **Detail E.**
3. Install three (3) jamb brackets to each vertical post using a dead blow hammer at the locations indicated in **Figure 18.** (Remove temporary horizontal when required.) Be sure the rivets on the brackets are securely seated in each embossed pocket.

The top bracket on each vertical post must have an extra tab with a threaded insert (for attaching the door header). **Detail F.**

4. Align the countersunk holes on each of the jambs with the threaded inserts on the jamb brackets. Use two (2) screws provided to attach the jamb to each jamb bracket. **Figure 19.**

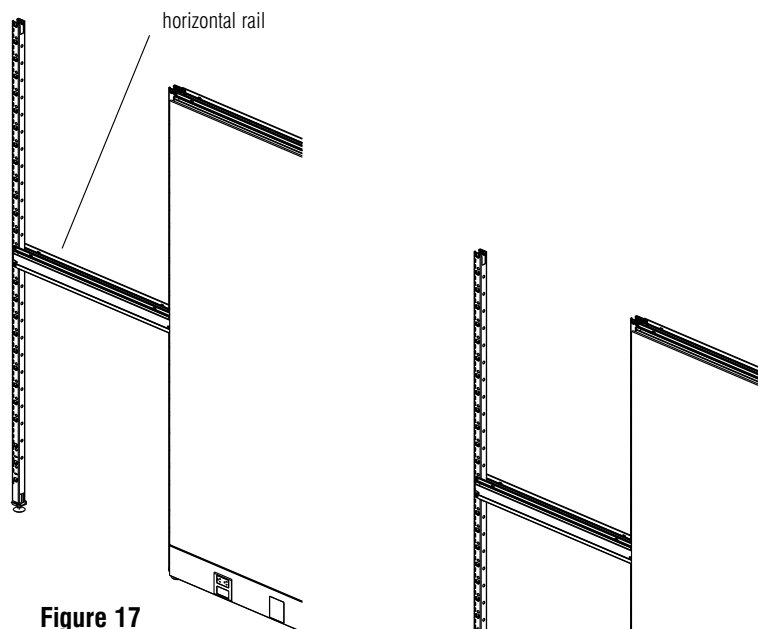
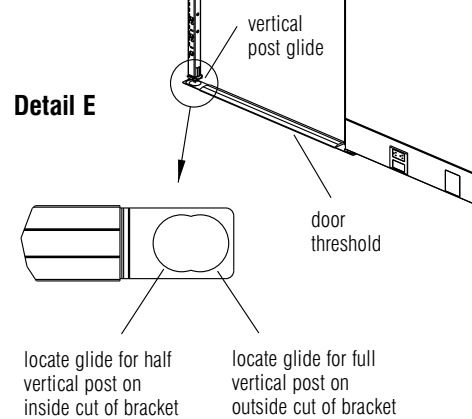

Figure 17



Detail E

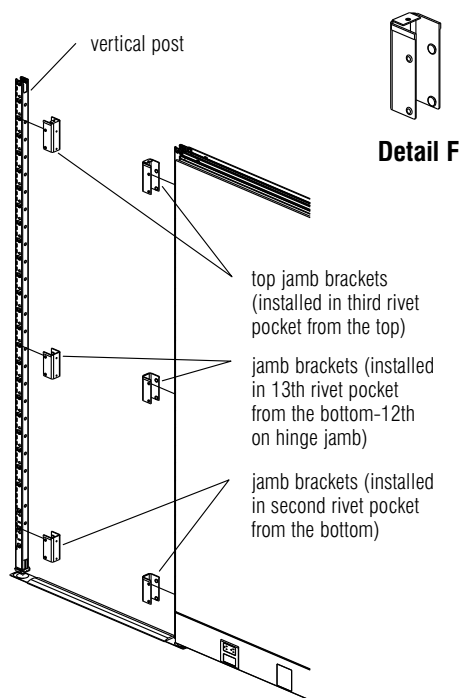

Figure 18

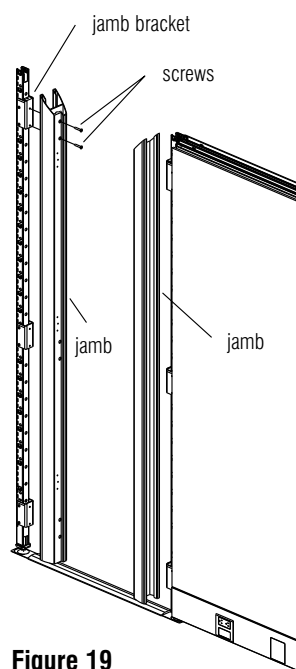

Figure 19

Door Installation

5. Align the header assembly with the jambs attached to the vertical posts. Holes in the brackets at each end of the header assembly should line up with the threaded inserts in the extra tab of the top jamb brackets. Use the screws provided to attach each header bracket to the top jamb brackets. **Figure 20.**
6. Install the top horizontal rail to the vertical posts through the installed door header. **Figure 20.**
7. Adjust the doorway by positioning the vertical posts if needed.
8. If a door is used, install the door with hinges to the hinge jamb with screws provided. Adjust the door by positioning the vertical posts and setting the height of the glides to achieve the required operation. **Figure 21.**

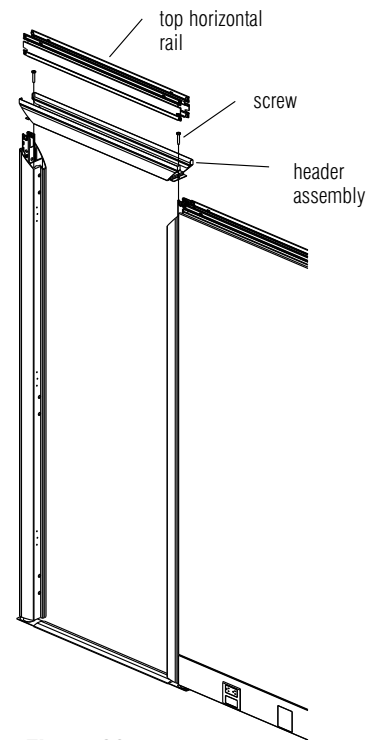

Figure 20

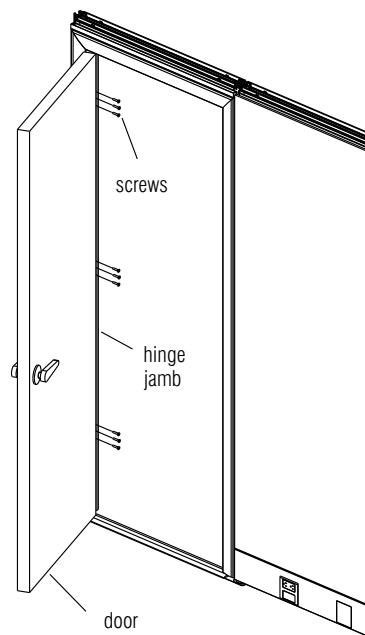

Figure 21

Off-Module Panel Installation

PowerWorks Off-Module Panel Connector (OMPC) allows a PW panel to be attached perpendicular at any point along a PW spine wall.

The OMPC and half post is factory assembled. By design the top of the half post will be approximately 1" higher than the top of the OMPC. **Figure 22.**

1. Position the OMPC assembly at the point where it is to be connected to the PW spine wall. **Figure 23.**

Note: The OMPC must be same height as the height of the horizontal rail to which it attaches.

2. Loosen the clamping screw to allow the top clamp to be inserted into the reveal between tiles. **Detail G.**
3. While holding the OMPC upright, insert the bottom clamp into the reveal located directly above the PW raceway door. The clamp must engage into the slot of the steel horizontal rail. **Detail H.**
4. Check for plumb and tighten clamping screw.
5. Adjust the glide so the post is appropriately supported.
6. Install top cap trim as shown in **Figure 24.**

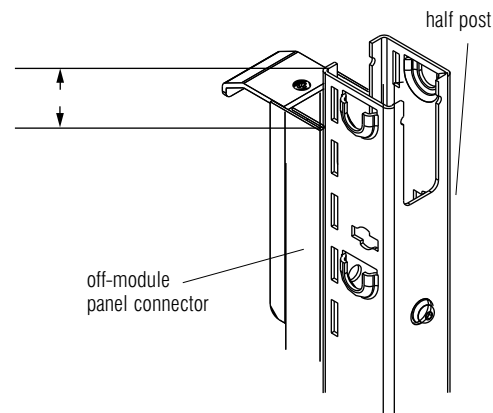

Figure 22

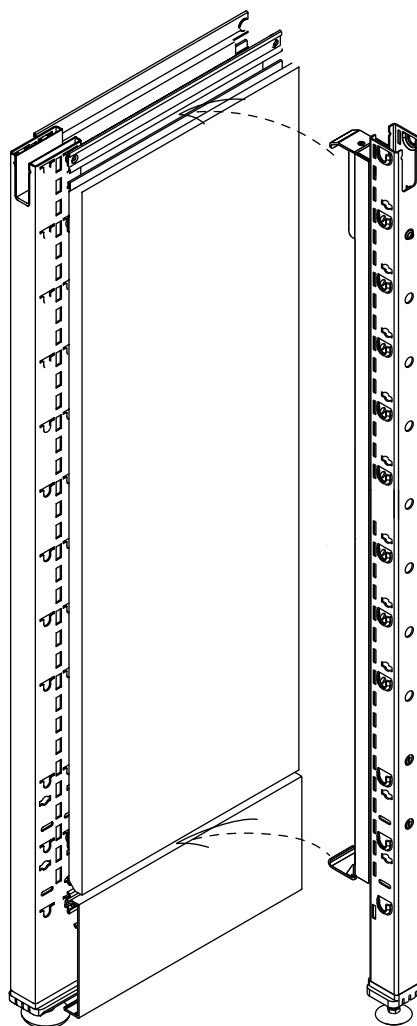
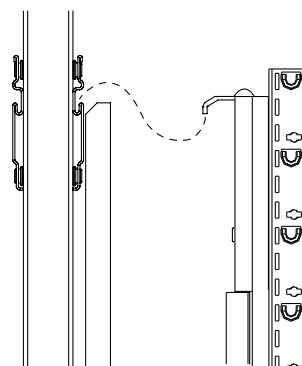
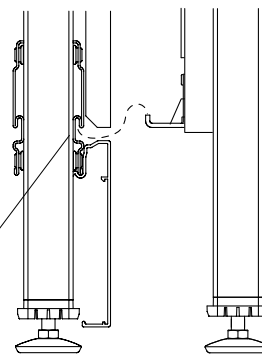

Figure 23



Detail G



Detail H

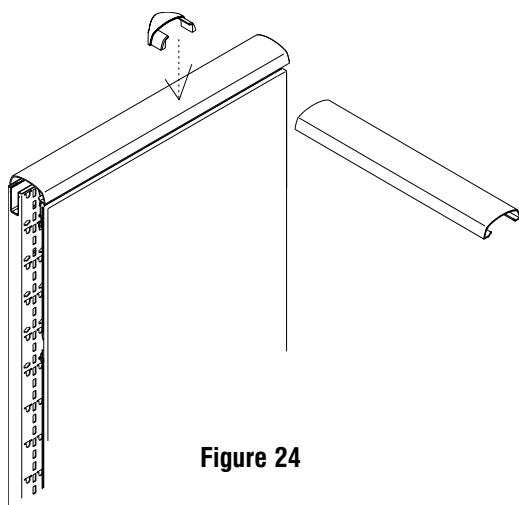

Figure 24

Off-Module Worksurface Installation

PowerWorks Off-Module Worksurface Bracket allows a worksurface to be attached at any point along a PW spine wall. The bracket is spaced away from the panel 3 4" to allow the removal of tiles from the spine wall. The use of these brackets will create a 1 3 4" space between the rear edge of the worksurface and the tile of the spine wall. **Figure 25.**

1. Position the off-module bracket at the point where it is to be connected to the PW spine wall. **Figure 25.**
2. Corner worksurfaces can be attached to the spine wall using off-module connectors and then connected directly to the perpendicular wing wall using cantilever brackets. **Figure 26.**
3. Loosen the clamping screw to allow the top clamp to be inserted into the reveal between tiles. **Detail I.**
4. While holding the off-module bracket upright, insert the bottom clamp into the reveal located directly above the PW raceway door. The clamp must engage into the slot of the steel horizontal rail. **Detail J.**
5. The position of the cantilever bracket (under the worksurface) when used to support two worksurfaces 'shared' is 1" different than when used as an 'end of run'. **Figure 27.**
6. Check for plumb and tighten clamping screw.
7. Engage the teeth of the worksurface cantilever brackets into the vertical slots of the off-module bracket.
8. Position the worksurface on the cantilever brackets in either the 'shared' or 'end of run' position. **Figure 27.**
9. Mark and drill pilot holes for #14x1" tapping screw.

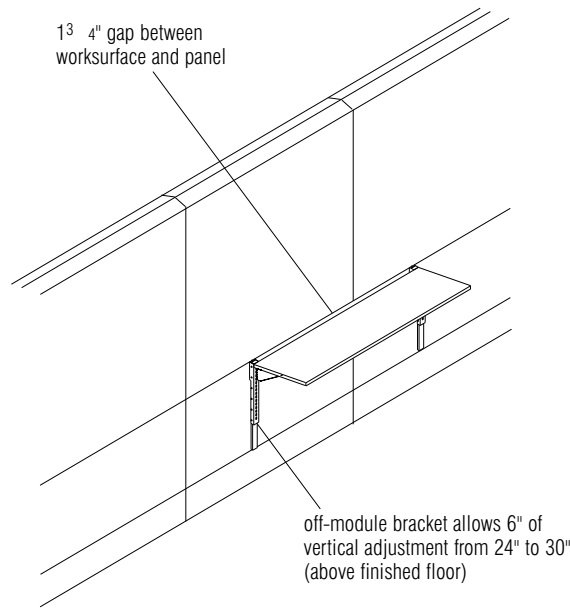
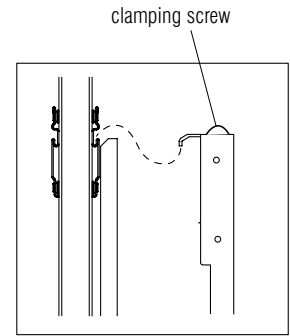
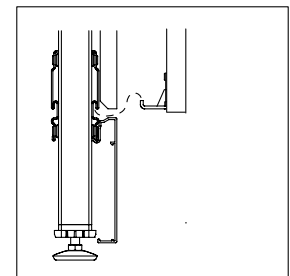

Figure 25



Detail I



Detail J

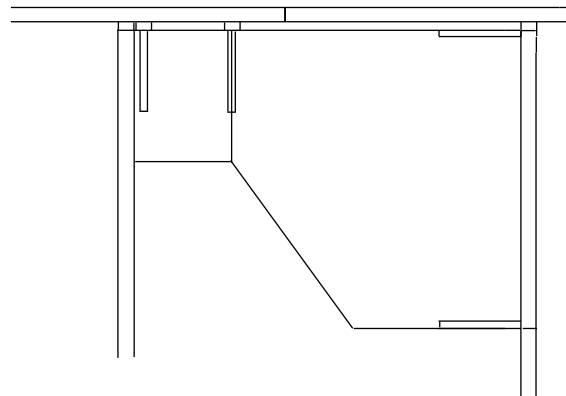

Figure 26

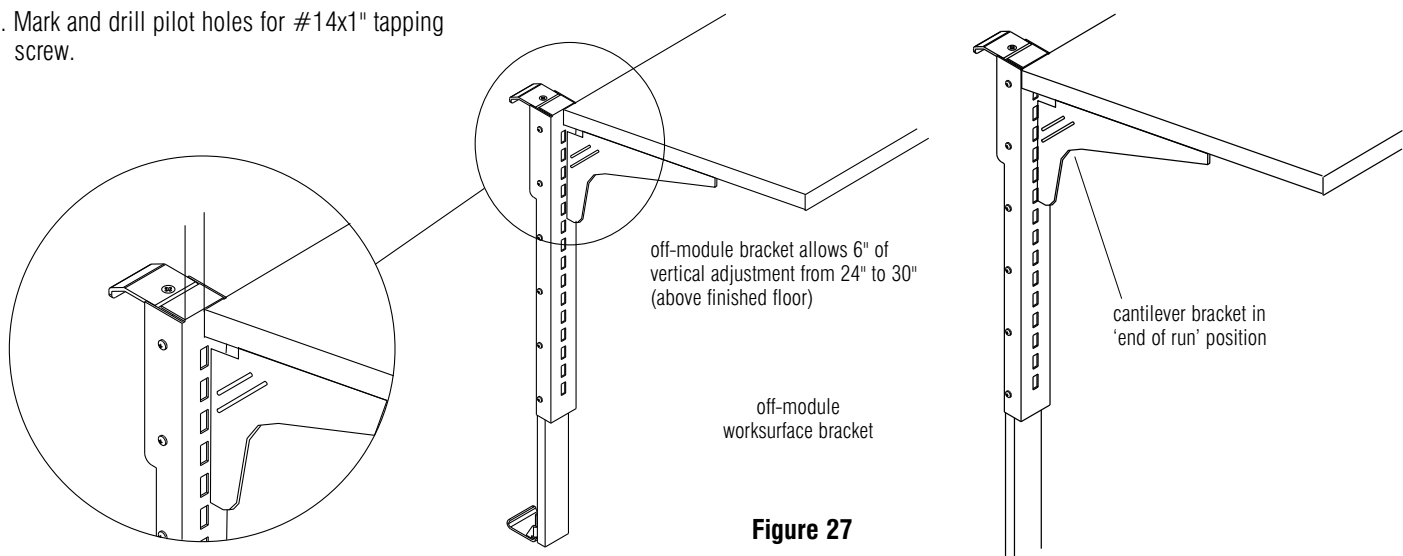

Figure 27

Overhead Cabinet Assembly

Note: The following overhead cabinet assembly steps refer to both off-module and on-module cabinet types. The type of mounting bracket used determines the type of cabinet being assembled. Also, if cabinets are being pre-assembled and cabinet type (off-module or on-module) is to be determined at a later time, the mounting brackets may be installed at a later time.

1. Assemble the cabinet back, side panels and mounting brackets (off-module or on-module) together by inserting the holes in the side panels and mounting brackets through the studs on the cabinet back. Loosely fasten the parts together with six flange nuts as shown. To avoid scratching side panels during bottom shelf assembly (step two), do not tighten flange nuts at this time. **Figure 28.**
2. Set the bottom shelf into position by locating the side flanges of the bottom shelf over the lower support flanges of the side panels. **Figure 29.**

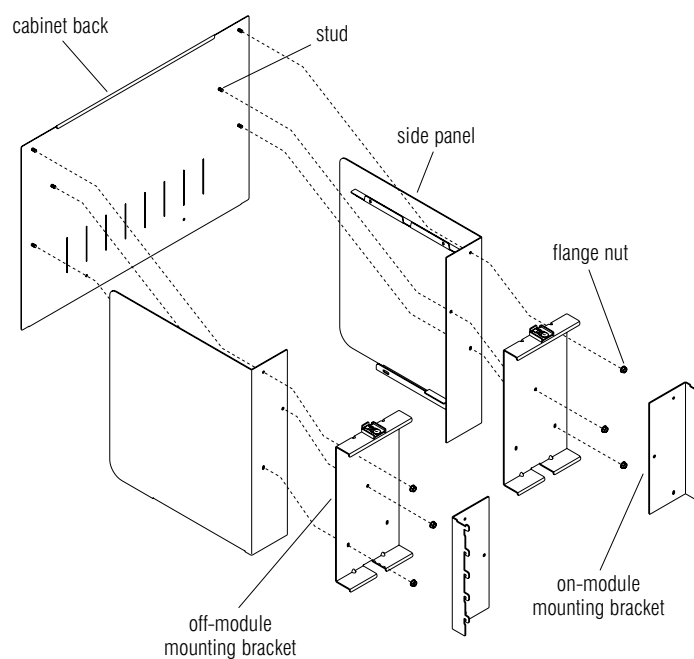

Figure 28

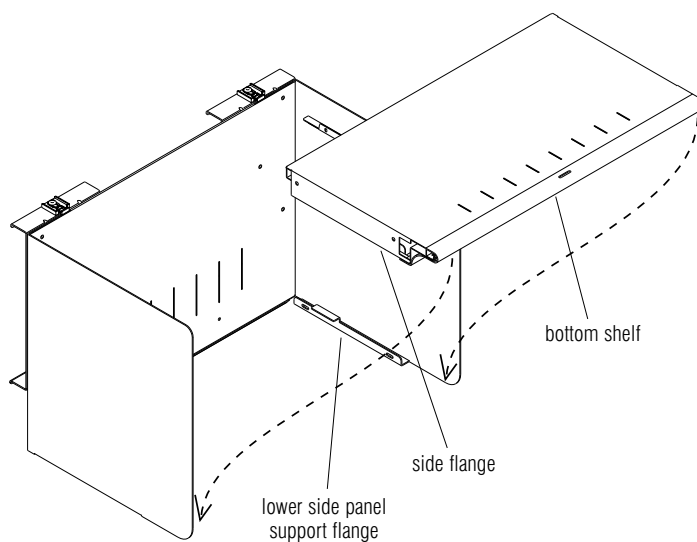

Figure 29

Overhead Cabinet Assembly

3. Press the bottom shelf down and adjust until the four screw holes in the bottom shelf side flanges are visible through the slots in the side panel lower support flanges. From under the cabinet, install four #8 x 3/8" self-tapping screws through the slots in the side panel support flanges. Do not tighten completely. At the lower rear of the cabinet, install two #8 x 3/8" self-tapping screws through the back and into the shelf. Do not tighten completely.

Figure 30.

4. Place the overhead top assembly over the upper support flanges of the side panels. Tap the top down into place and align the round front edge with the matching radius on the side panel. Install and tighten four #8 x 3/8" self-tapping screws through the four larger oblong holes in the rack and pinion door mechanism inside the top assembly. **Figure 31.**

5. The recessed door can now be pulled out and lowered to its closed position. Adjust the bottom shelf so the door hangs straight and flush with the end panels. Tighten the four screws under the bottom shelf at this time. Using the door lock key (taped to the inside of the top assembly for shipping) engage the lock cam into the locked position by turning the key clockwise.

6. After the top and shelf have been checked for proper alignment tighten all hardware.

Note: For those users who wish to retain the key in the lock when storing the recessed door, there is a set of door stops that may be installed to prevent door from opening past the key. If the door is opened with the key in the lock, damage to the overhead cabinet and/or a key broken off in the lock may result without door stops.

7. To install recessed door stops, open and store recessed door. Next, pull door out about four inches, enough to avoid interference with the installation of the door stop. Remove the two rear #8 x 3/8" screws (installed above). Press #8 x 3/4" self-tapping screws through each door stop and fasten the door stops to the flipper door racks on each side of the overhead where the two rear screws were removed.

Figure 31.

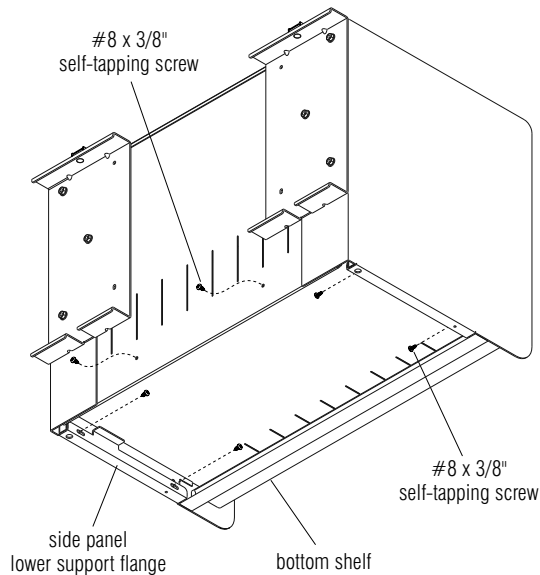

Figure 30

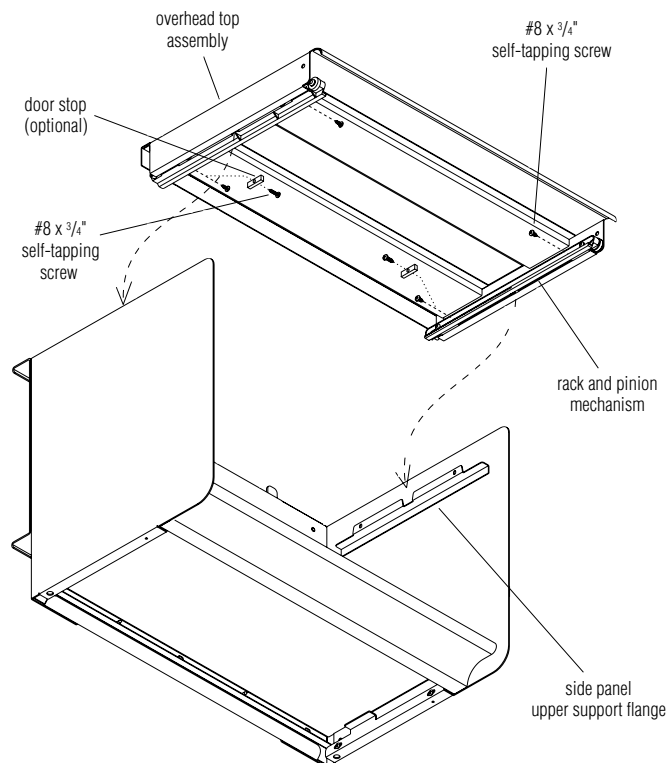

Figure 31

Overhead Cabinet Assembly

8. Hang the cabinet unit onto the panel using the appropriate mounting instructions below.

Off-Module Mounted Cabinets

Off module mounted cabinets can only be hung with the top aligned to a 12" tile. To make hanging the overhead easier, remove the tile or top cap directly above the overhead. With the overhead locks pulled out (toward the front of the cabinet), hang the top and bottom of the mounting bracket into the tracks of the panel's horizontal rail. Make sure the cabinet is hanging on the horizontal rail and not on the tile. After the cabinet is hung in the track, move it to the desired position by gently lifting up while sliding it. Secure the cabinet on the tracks by pressing the overhead locks into the track. **Figure 32.**

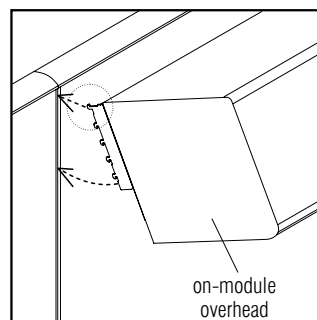

Detail K

On-Module Mounted Cabinets

The mounting brackets have integral teeth that engage in the vertical furniture hanging slots in the panel frame. Locate the on-module cabinet at the height that is desired on the panel. Engage the upturned tooth of the top hook (circled) into the panel frame by holding the cabinet bottom out about 30°, then rotate the cabinet bottom down to engage all the remaining teeth. When all teeth are engaged, press down on the cabinet to lock in place.

Detail K.

Caution: To remove the cabinet assembly from the panel, push the bottom of the cabinet straight up about 1/4" and rotate the bottom out toward you to about 30°. Pull the cabinet straight out and down. Do not force the side panel, damage to the top tooth may result.

9. When two or more cabinets are installed next to each other, secure them together with a ganger plate. Fasten a ganger plate to the cabinet bottoms with two #8 x 5/8" black screws. **Figure 32.**

10. To install shelf dividers (optional), first place the front hook of the divider into the front slot of the shelf. Then rotate the rear of the divider down until the the tab snaps into the vertical slot in the cabinet back, **Figure 32.** To remove the divider, press lightly on the cabinet back to release the rear tab and rotate it out.

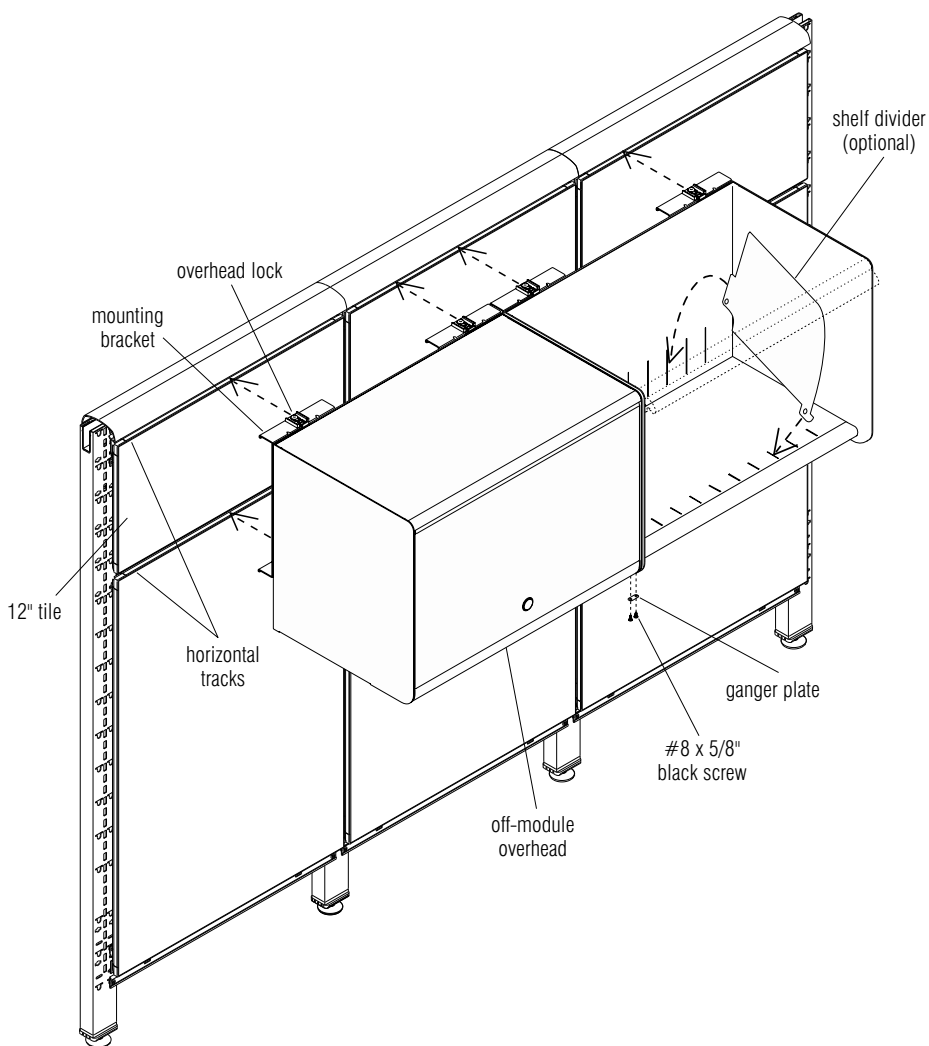

Figure 32

Worksurface Installation

1. Cantilever brackets are attached to the panels by inserting the teeth along the rear edge into the slotted trimrail on the panel. Cantilever brackets are height adjustable in 1" increments. Each worksurface will be supported by at least (2) cantilever brackets (1 left, 1 right).
2. On the left end of the panel the worksurface is going to be attached to, determine the desired height of the work surface (typically about 29¹/₂" to 30" above the floor).

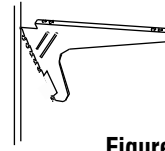

Figure 33

3. Locate the trimrail slot approximately 2¹/₄" below the desired worksurface height.
4. Holding the front edge of a left hand cantilever bracket (stamped with an "L") higher than the rear edge with the teeth, slide the top safety tooth into the trimrail slot you located in step 3. **Figure 33.**

5. Pivot the cantilever bracket down until all the teeth are in the slots and the top of the cantilever bracket is approximately horizontal. **DO NOT FORCE THE CANTILEVER BRACKET. FORCING MAY CAUSE DAMAGE TO THE TOP SAFETY TOOTH, OR THE PANEL FABRIC.**

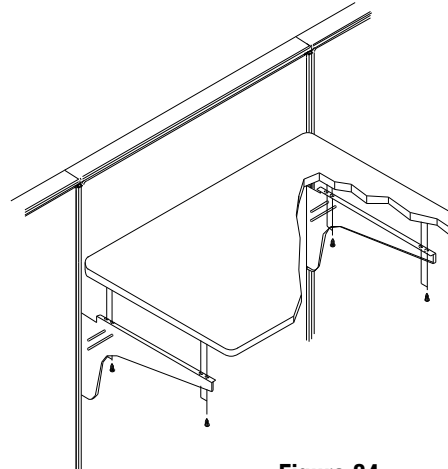

Figure 34

6. Push the cantilever bracket down about 1/4" so all the teeth are engaged in the slots.
7. Repeat the steps with a right hand cantilever bracket (stamped with an "R") on the right end of the panel.

NOTE: On worksurfaces 60" or longer and on 90° corner worksurfaces, a second "L" cantilever bracket is installed in the panel joint near the center of the worksurface. Figure 35.

8. Set the worksurface on the cantilever brackets and line up the worksurface pilot holes with the slots on the cantilever brackets. Secure the work surface to the brackets using (2) #14 x 3/4" screws in each bracket. **Figure 34.**

CAUTION: To remove a cantilever bracket from a panel, the worksurface must be removed. After removing the worksurface, push up on the bottom of the cantilever bracket about 1/4". Grasp the bottom of the bracket and rotate it up and towards you until the top-back corner of the bracket almost touches the panel. Pull the bracket straight out towards you.

DO NOT FORCE THE CANTILEVER BRACKET. FORCING MAY CAUSE DAMAGE TO THE TOP SAFETY TOOTH, OR THE PANEL FABRIC.

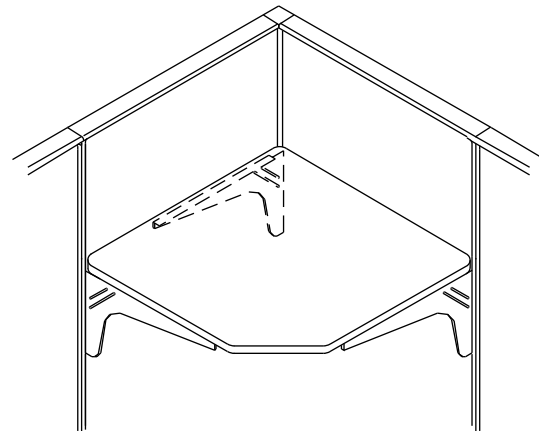

Figure 35

Worksurface Support Panel

1. Attach support panel bracket to top of worksurface support panel with (4) #14 x $\frac{3}{4}$ " tapping screws into the pre-drilled holes.

Figure 36.

2. Retract the glides on the worksurface support panel completely. Insert the teeth of the support panel into the trim rail grooves so that the top of the support panel is approximately $28\frac{3}{8}$ " from the floor. Adjust the glides down to the floor to lock the support panel teeth in place. Using a pry bar to lift the support panel into full engagement will make adjusting the glides easier.

3. Mount the worksurface on the worksurface support panel. Attach the worksurface to the cantilever bracket and the support panel bracket using (4) #14 x $\frac{3}{4}$ " tapping screws.

Figure 37.

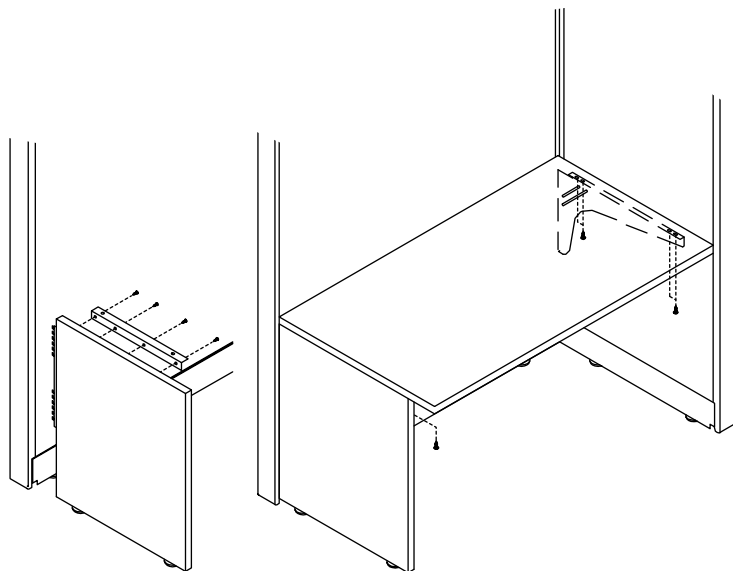

Figure 36

C-Leg Worksurface Support

1. Retract the glides on the C-leg completely into the bottom leg. Insert the teeth on the C-leg into the slots in the trimrail groove so the top of the C-leg is about $28\frac{3}{8}$ " from the floor. Adjust the glides down to the floor to lock the C-leg in place. Using a pry bar to lift the C-leg into full engagement will make adjusting the C-leg easier. The upward pointing teeth should engage into the trimrail slots.

2. Mount the worksurface on the C-leg, and align the C-leg so it is straight, front to back, below the worksurface. Attach the worksurface to the C-leg using (3) $2\frac{3}{4}$ " screws that go through the holes in the C-leg top tube, and into the worksurface.

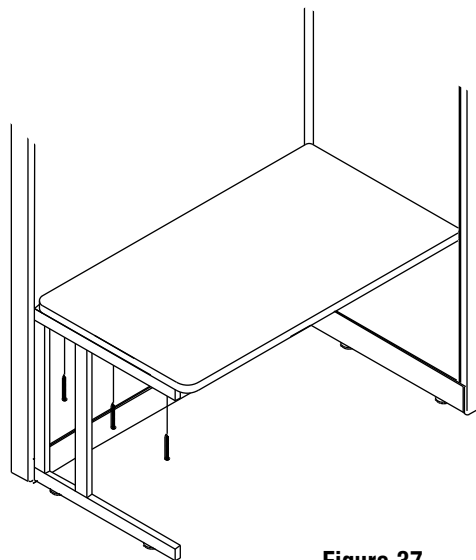

Figure 37

Worksurface Bracket Guidelines

The following worksurface illustrations are for typical worksurface bracket applications. The proper placement/usage of cantilever brackets, worksurface support brackets and splice plates is important and will lessen the chance of shortages at installation time.

Note: A left-hand cantilever bracket is specified in all corner worksurfaces. Rectangular worksurfaces 66" or greater in length are shipped with an additional left-hand cantilever bracket which is center mounted.

A-R = 15" Cantilever Bracket (right hand)

A-L = 15" Cantilever Bracket (left hand)

B-R = 20-1/2" Cantilever Bracket (right hand)

B-L = 20-1/2" Cantilever Bracket (left hand)

C = Worksurface Support Bracket

D = Splice Plate

E = D-Leg

F-R = 10-1/2" Dual Curve Bracket (right hand)

F-L = 10-1/2" Dual Curve Bracket (left hand)

G = Flat Bracket

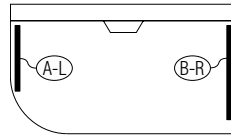

Radius Corner Peninsula, 24" deep (left shown, right opposite)

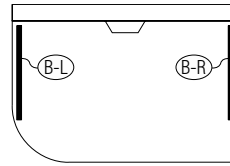

Radius Corner Peninsula, 30" deep (left shown, right opposite)

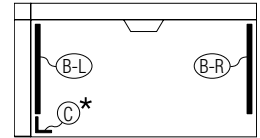

Rectangular Surface with Return Panel
*install as shown only when specified on cad print

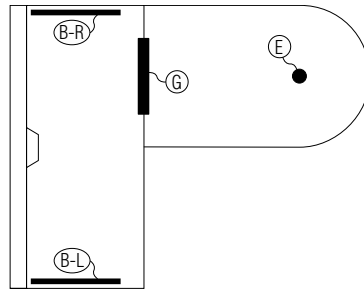

"D" Shape Peninsula (end mount to another worksurface)

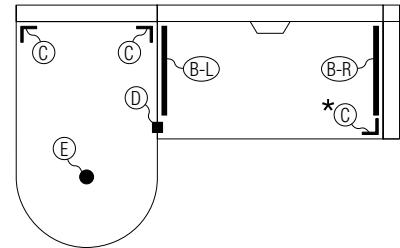

"D" Shape Peninsula (end mounted to panel) with Adjoining Rectangular Worksurface
*install as shown only when specified on cad print

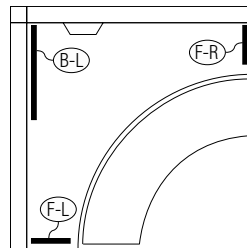

Dual Curvilinear 90° Corner with PositionMate

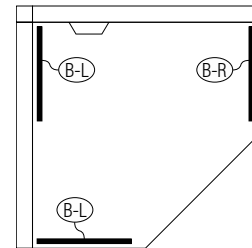

Diagonal 90° Corner

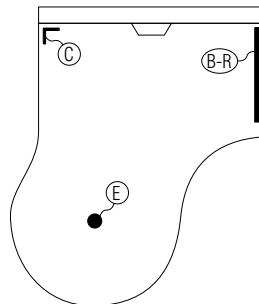

"P" Shaped Peninsula (left shown, right opposite)

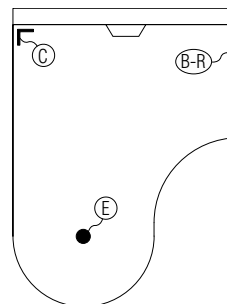

Piano Peninsula (left shown, right opposite)

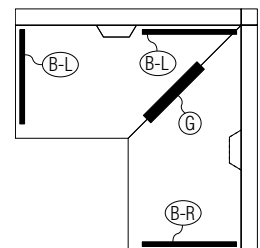

Mitered Rectangular

Worksurface Bracket Guidelines

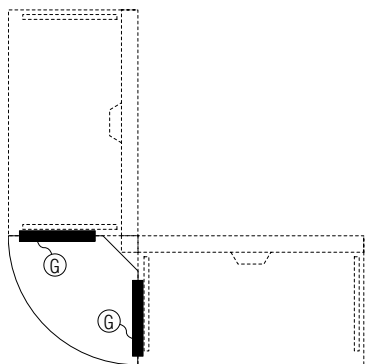

Quarter Round Surface

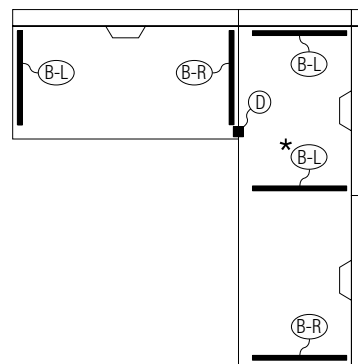

Adjoining Rectangular Surfaces

*center cantilever bracket (always left hand)
used on 66" and greater worksurfaces

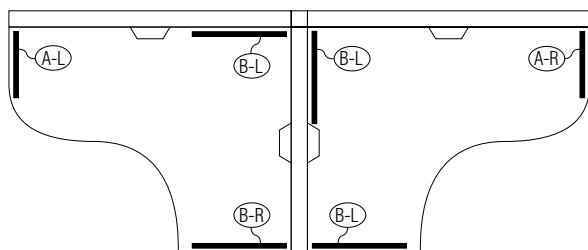

**Radius Shoe Pair
(24" deep)**

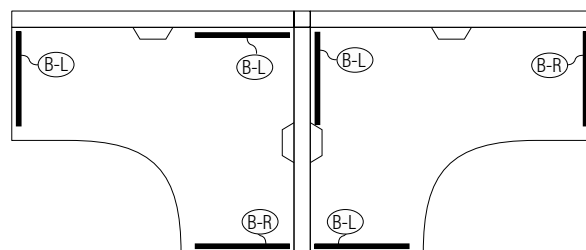

**Square Shoe Pair
(30" deep)**

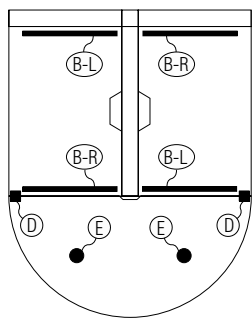

**Conference End with
Adjoining Rectangular Surfaces**

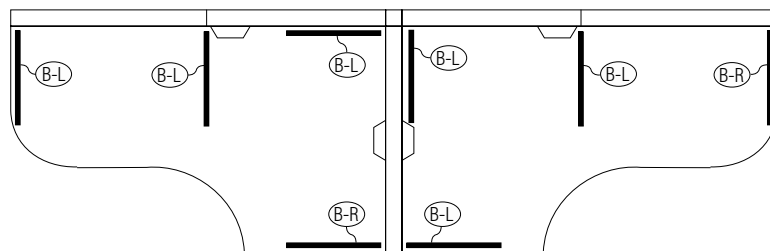

**Radius Shoe Pair
(30" deep)**

Electrical Installation

WARNING: Assembly of all mechanical frame components must be completed before making any electrical connections. All electrically interconnected furnishings shall also be mechanically interconnected.

Product Overview

The 810 Universal electrical system is available in two versions: a six-circuit system (622) and a four-circuit system (442). They are not interchangeable and are differentiated by the color of the UL label; 622 is green and 442 is blue.

Installing Rigid Wireway

Rigid wireways are installed by first installing the plastic clips into the appropriate slot on the horizontal rail. Slide the clips near side open saddles (**Figure 38**) on to the frame until a snamp is heard. Then squeeze frame until the far side saddles engage the rail and affix in place manually, or with a soft mallet.

Rigid wireways hang off the lowest rail (base power) (**Figure 38**) but sit on top of the rails at other heights (ADA, worksurface height and standing height). **Figure 39**.

1. Orient the wireway so the **(N)** points toward the top of the panel. **Figure 40**. For base power, position the rigid wireway below the horizontal rail, insert plastic clips as stated above. Then, align the steel mounting brackets to the two holes in the plastic clips and insert one #10-24 x 3/8" screw from each side, on both ends. **Detail L**.
2. For power at other heights, position the plastic clips on the top of the horizontal rail. **Figure 39**. Continue installing rigid wireways as required.

Hint: To remove the wireway, insert a screwdriver into the mounting slot of the horizontal rail until the clip can be pulled free (**Figure 40**) or remove all four screws.

Installing Horizontal Jumper

Power is passed from panel to panel by using a horizontal jumper. **Figure 39**. Horizontal jumpers use fiberglass mesh and come in two different lengths (17" & 20"). The 17" jumpers are used on in-line conditions, while 20" jumpers are used to pass straight through an intersection or around a 90° corner. See the diagrams on the following page for example installations. **Examples A-E**.

Jumpers plug into one of two open sockets on each end of the rigid wireway.

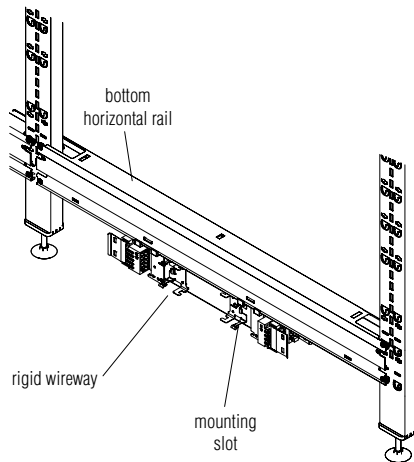

Figure 38

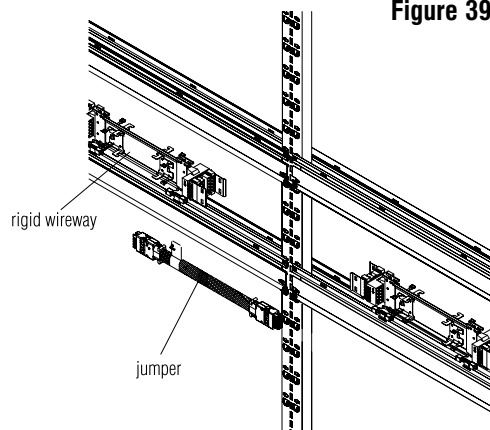

Figure 39

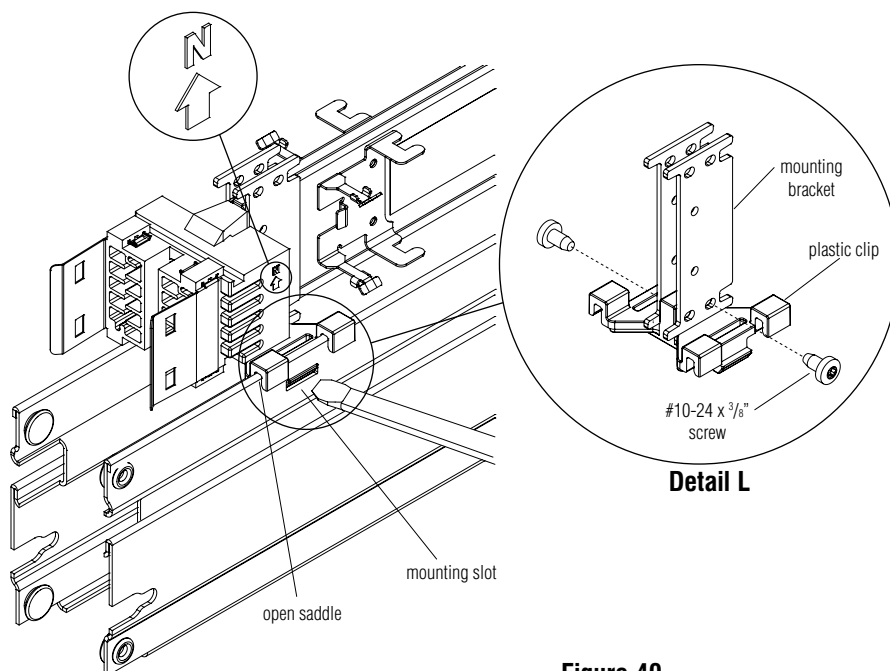
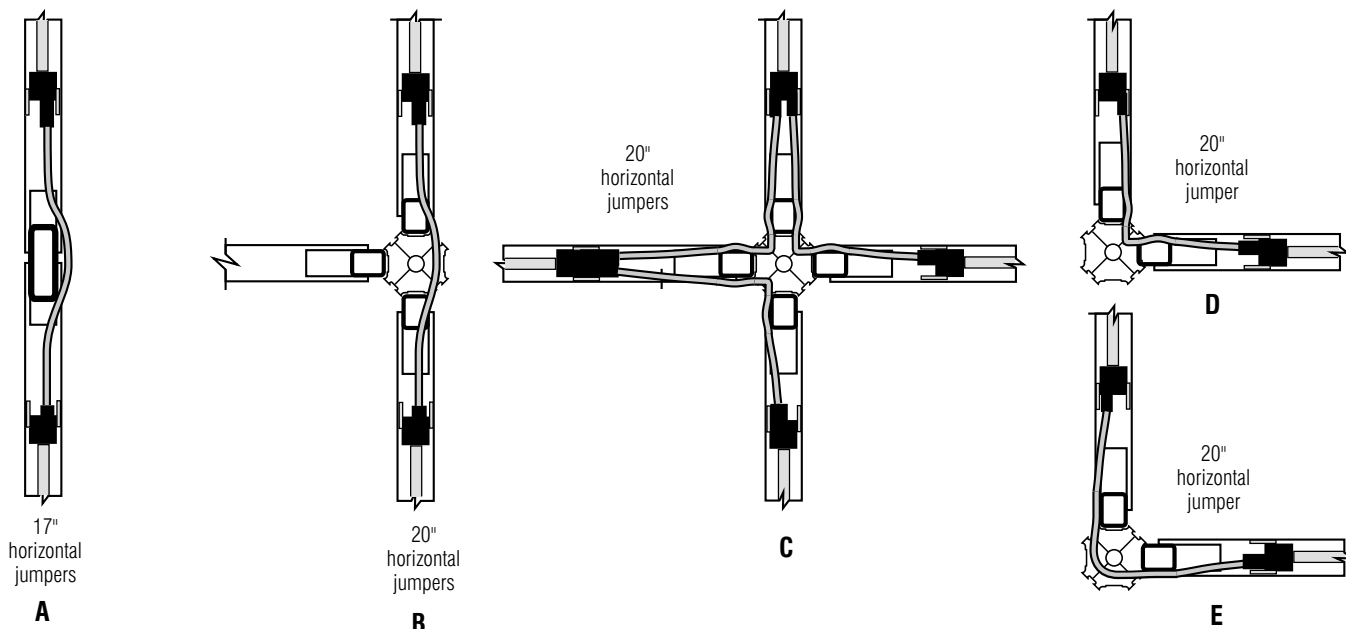

Figure 40

Installing Horizontal Jumper (continued)

To remove a jumper, pull out slightly on the steel tabs on the wireway until the jumper can be pulled from the connection port.

Note: Horizontal jumpers will pass behind raceway tiles, but they will not pass behind acoustical tiles.



Preferred horizontal jumper installations
(Examples A-E)

Installing Vertical Jumper

Vertical jumpers are used to run power within a single panel between two different heights. There are two lengths of vertical jumpers (20" & 56"). The 56" long vertical jumper is capable of running power from the base to any other height within the panel, while the 20" short vertical jumper is used to run power between two adjacent heights (i.e. ADA height to worksurface height or worksurface height to standing height). See the diagram on the following page for example installations.

Example F.

Note: The 56" jumper must be used to run power from base to ADA height.

1. Install the vertical jumper in the same manner as the horizontal jumper, connecting the ends of the jumper to rigid wireways at two different heights of the same panel. **Figure 41.**

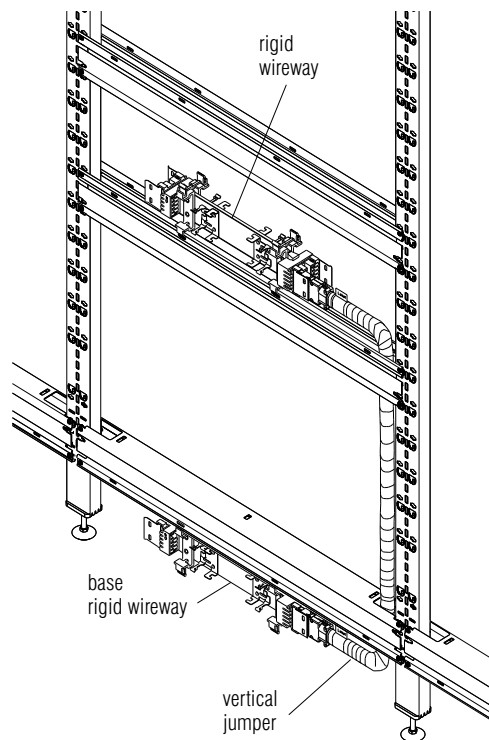
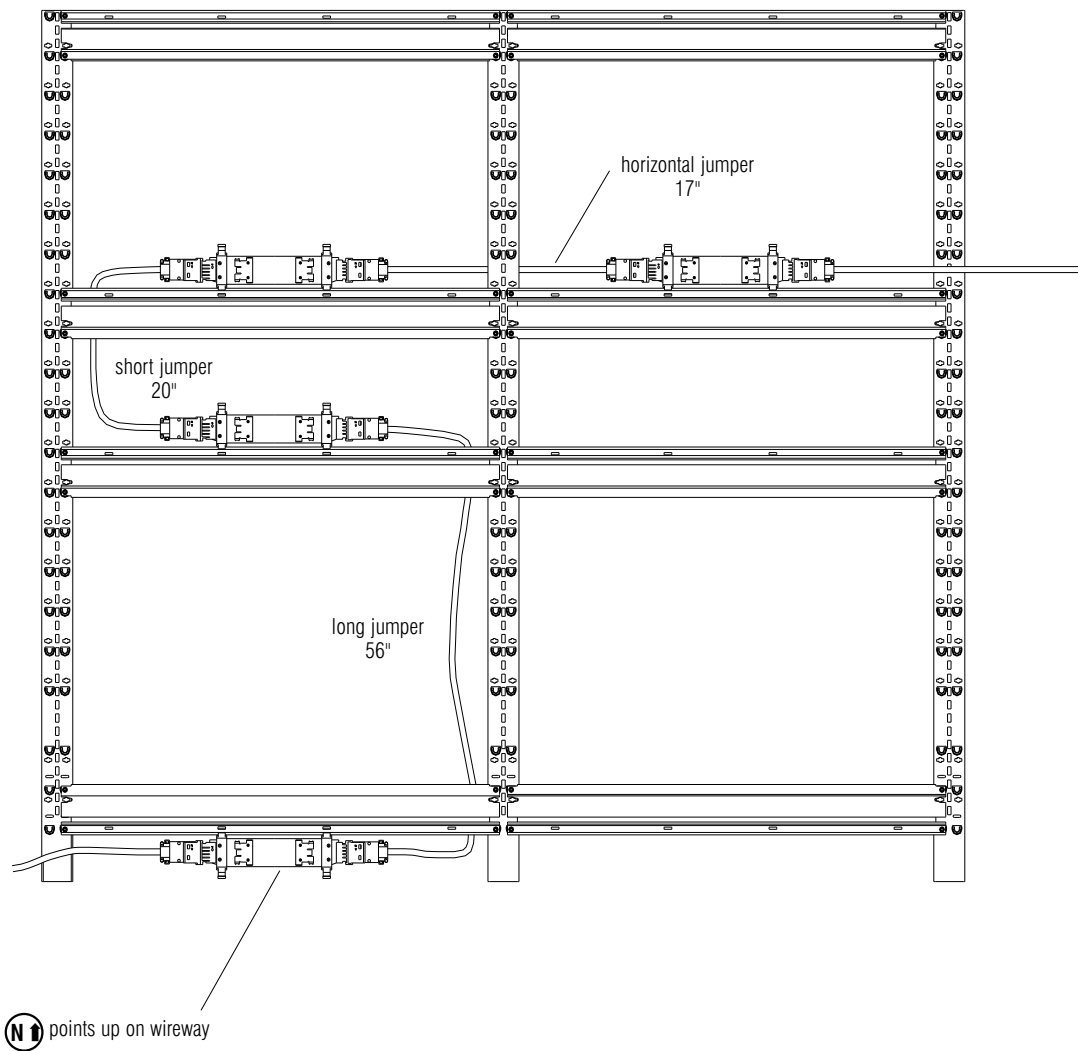

Figure 41

Electrical Installation



Typical rigid wireway and jumper installation for 810 Universal electrical system
(Example F)

Receptacle/Bezel Installation

Installing in Base Raceway

1. Determine the position at which the receptacle will be installed and ensure a rigid wireway is already mounted behind the base raceway door.
2. Remove the base filler plate by opening the raceway door and unsnapping it from inside the raceway. **Figure 42.**

Hint: Store base filler plate for future use.

3. Close the raceway door and snap a bezel into the opening from the front of the base (note “this end up” orientation of bezel). If data connection is required, a data faceplate can now be installed (supplied by the customer) into the unused opening in the bezel. Refer to Planning Guide **Data Cable Management** for additional information. If data faceplates are not being used, snap the included bezel filler plate into the unused bottom opening of the bezel. **Figure 43.**

Note: The bezel filler plates always occupy the lower of the two openings on bezels in base raceways. The bezel filler plate can be snapped in place such that it is flush with the bezel face (**Figure 43**) or rotated to allow data cables to exit.

4. Open the base cover and snap the appropriate receptacle into the rigid wireway behind the location where the bezel has been installed. **Figure 44.**

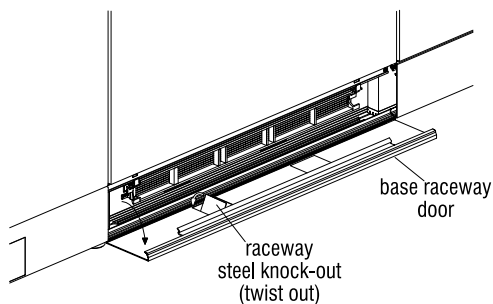

Figure 42

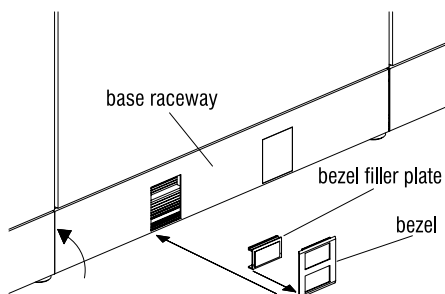

Figure 43

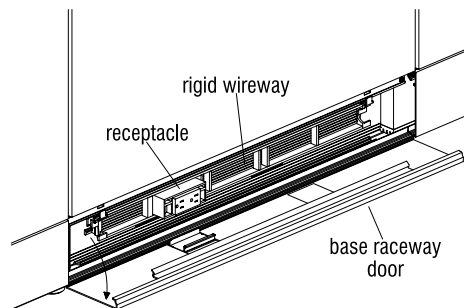

Figure 44

Receptacle/Bezel Installation

Installing at Other Heights

To install receptacles at heights other than in the base raceway, requires raceway tiles. Raceway tiles are 12" high and have a fabric-wrapped steel face.

1. Determine the position at which the receptacle will be installed and ensure a rigid wireway is already mounted behind the raceway tile.

2. Snap the bezel into place from the front of the tile (note "this end up" orientation of bezel).

Figure 45.

Note: Bezel filler plates always occupy the upper of the two openings on raceway tiles. The bezel filler plate can be snapped in place such that it is flush with the bezel face or rotated to allow data cables to exit.

See page 29.

3. Snap the appropriate receptacle into the rigid wireway behind the location where the lower opening is located.
4. Hang the raceway tile on the top hooks, then allow the tile to rotate down and snap the lower portion of the raceway tile into place by applying firm pressure near the location of the hooks. **Figure 46.**

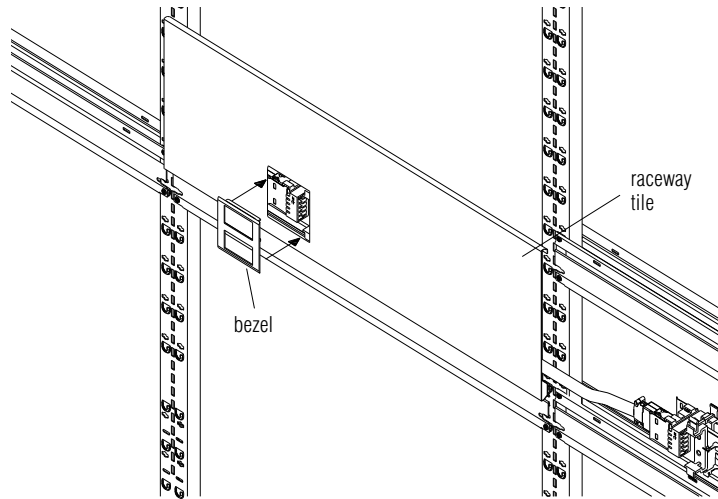

Figure 45

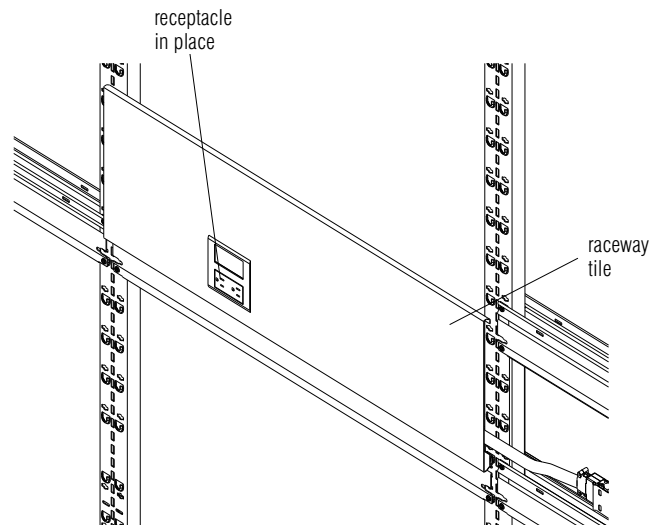

Figure 46

Installing Base Raceway

Base raceway consists of the raceway, base locks and filler plates (panels 24" and wider only).

1. Slide the base raceway into place under the panel with the doors lying in the open position. When the raceway is centered under the panel around the glides, snap the trim up over the lip on the glide housings. **Figure 47.**

Hint: Base raceway installation is made easier if all glides have been turned down at least 1/4".

2. Push each base cover lock away from the center of the panel until the plunger pops down into the locked position. **Figure 48.** To ensure the lock is engaged, press inward on the lock. It may be necessary to press down on the plunger to ensure the lock engages.
3. Push the doors of the base raceway upward until they engage the lower horizontal. **Figure 49.** The base cover filler plates remain in position unless a receptacle is being used in that location. If there is a receptacle, snap the filler plate out from inside of the base cover and snap a bezel in its place from the front of the cover.

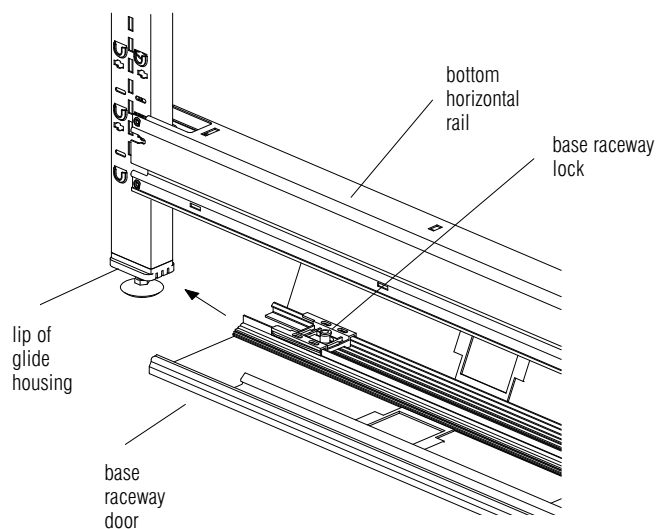

Figure 47

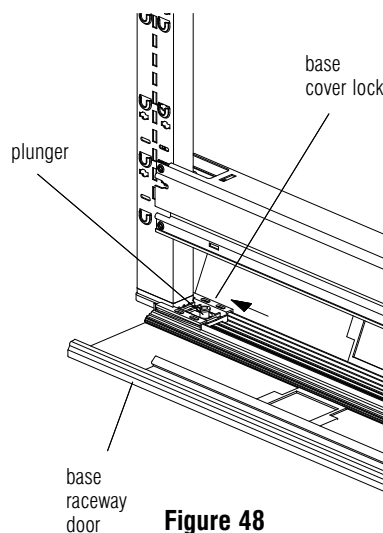

Figure 48

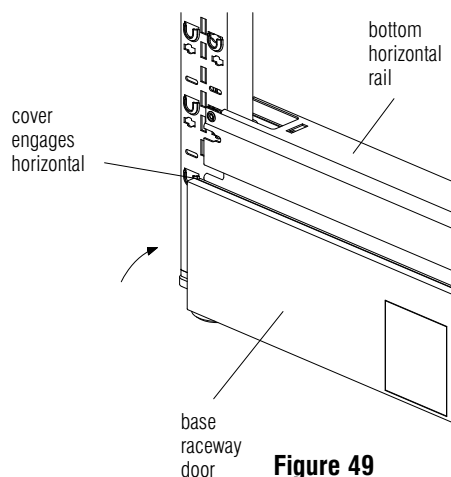

Figure 49

Base Trim Installation

Installing Base Trim at Intersections

When base trim is snapped into place at 90° and T-intersections, the upper tabs engage slots in the half post and the lower tabs snap over the lip on the half post glide housing. **Figure 50.**

Hint: Open the base raceway door to make it easier to engage the upper tabs into the slots of the half post.

Note: The glide housing at the bottom of the vertical posts must be oriented such that the recessed cut out is positioned under the slots **Detail M.**

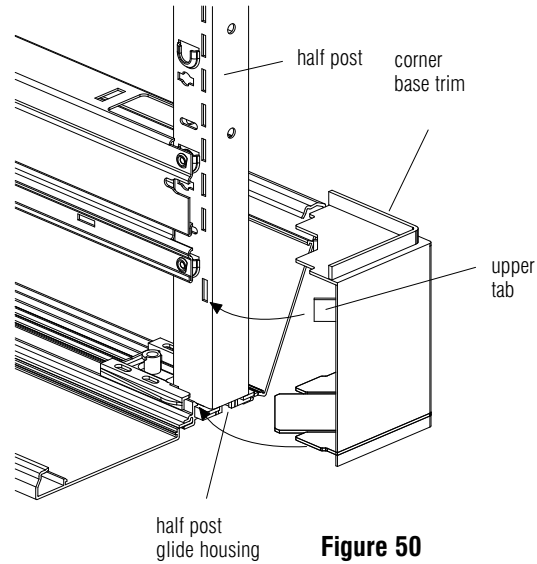
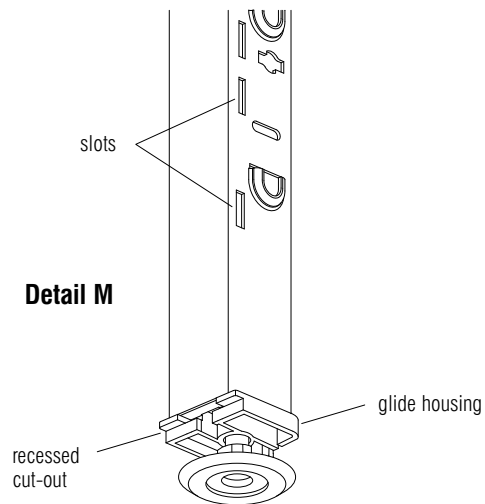

Figure 50



Detail M

Installing Universal Base Infeed

WARNING: Assembly of all mechanical frame components must be completed before making any electrical connections. All electrically connected furnishings shall also be mechanically interconnected.

Right-Hand Installation

Figure 51

1. Install the base module (receptacle portion) of the non-handed universal base infeed into the rigid wireway as shown. Use the same procedure you use for installing a receptacle. See page 29-30.
2. Install the base raceway door onto the panel.
3. Plug the pluggable portion into the base module by pushing it into the face and raising the lock strap up in the unlatched position.
4. When the pluggable portion is fully seated into the base module, the lock strap must be pushed down to latch the assembly together.
5. Install the universal base infeed cover with screw provided.

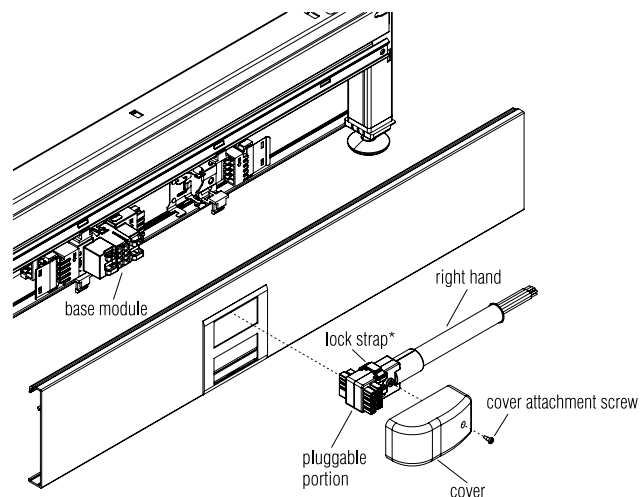

* lock strap shown in latched position

Figure 51

Left-Hand Installation

Figure 52

1. Follow steps as outlined in **Figure 51**, except rotate pluggable portion and cover 180 degrees as shown in **Figure 52**.

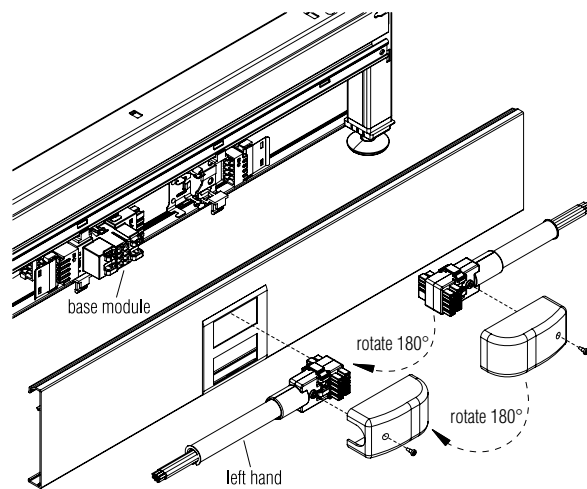

Figure 52

Power Infeed Installation

Installing Top Infeed

The top infeed consists of four parts: the power pole, the top infeed, panel trim and ceiling trim. The power pole and trim pieces are designed so they can be easily installed after power and data is run into the panel.

Note: Do not use the Base Infeed when powering from the ceiling.

1. Cut a hole in the ceiling tile the same size as the power pole to allow power pole to be held in place by the tile. Do NOT install power pole at this time.
2. Run the infeed through the notches in the end of the horizontal rail down to the rigid wireway. Attach to the rigid wireway at the end of the rigid wireway (the infeed attaches to the rigid wireway in the same manner as the jumpers). **Figure 53.**
3. Position the two panel trim top cap pieces around the infeed and any data cabling above the panel and snap them together. Then lower the combined part onto the panel; the trim should rest on the horizontal rail. **Figure 54.**

Note: Top cap needs to be trimmed “to fit” when installing trim via a hack saw and miter box to ensure a clean, proper cut.

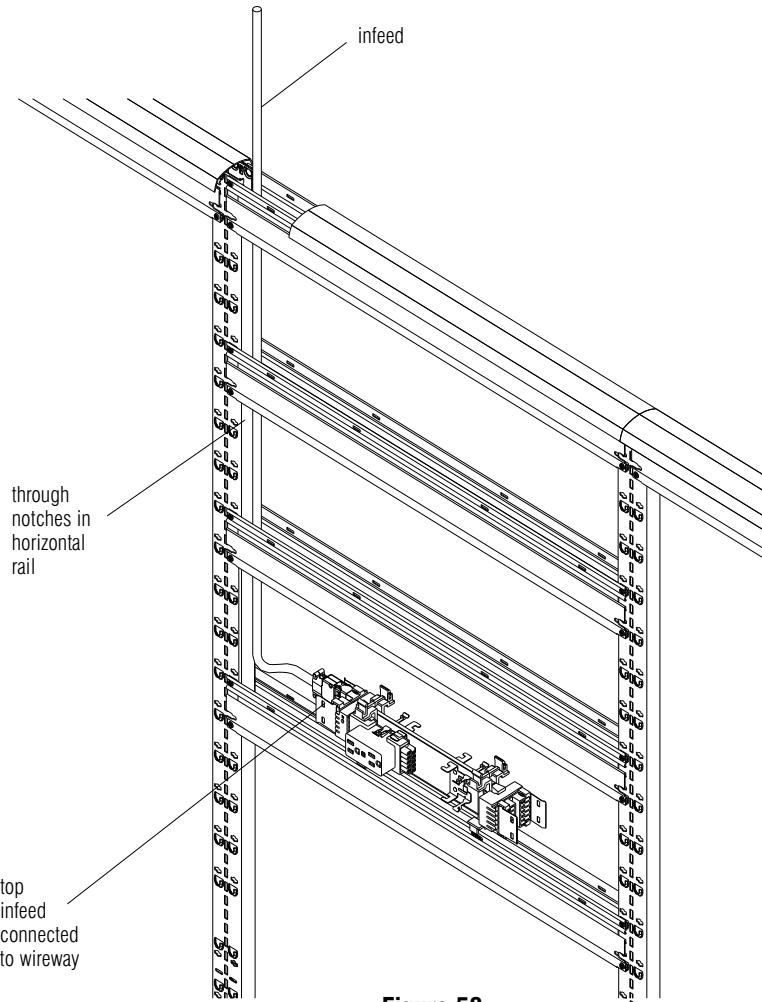

Figure 53

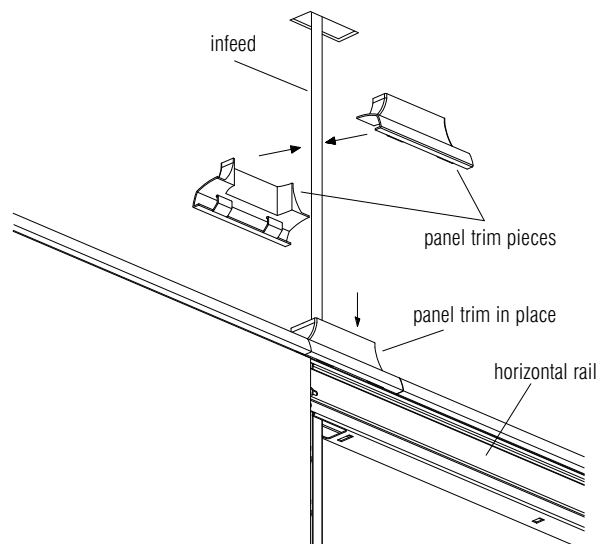

Figure 54

Installing Power Pole

1. Position the two halves of the power pole in the cutout in the ceiling tile, around the infeed and any data cabling, and snap the cover closed. Lower the power pole so it sits in the top of the panel trim. **Figure 55.**

2. Position the two ceiling trim halves near the ceiling and snap them together around the power pole. Slide the trim against the ceiling, trim the ceiling tile as necessary. **Figure 56.**

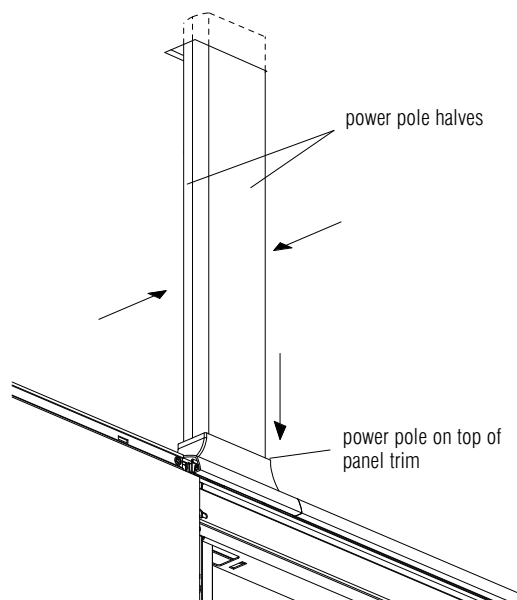

Figure 55

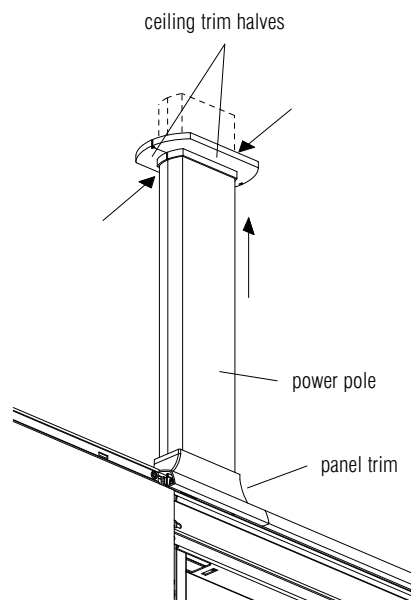

Figure 56

Data Cable Management

Data Cabling Under Top Cap

Data cabling can be laid in the trough of the top horizontal rail (contained under the top cap).

1. Begin laying the necessary cabling in the trough of the top horizontal rail. For 90° intersections, the optional 90° top cap cable guard can be slid in between half posts to enforce a 1" minimum bend radius around 90° corners. **Figure 57.**
2. To run data cabling from the top cap to other heights in the panel, route wires down through the notch in the end of the top horizontal rail. The horizontal rail cable guard can be snapped in place in the notch in the end of the horizontal rail (**Figure 58**) to enforce a 1" minimum bend radius. **Detail N.**

Note: Refer to the Planning Guide for **Cable Management Capabilities.**

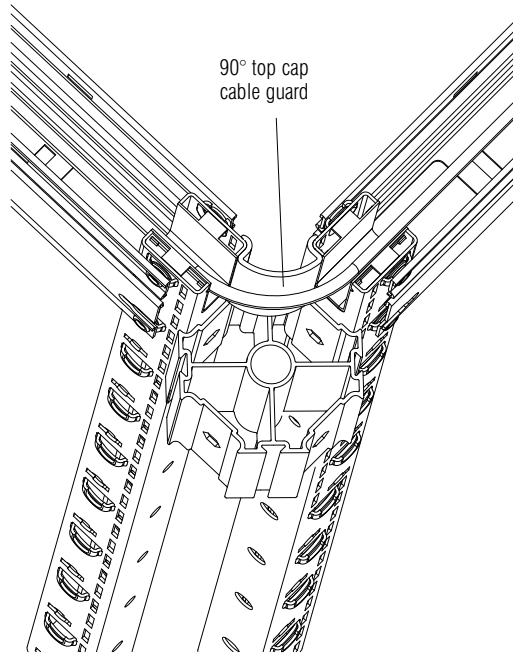
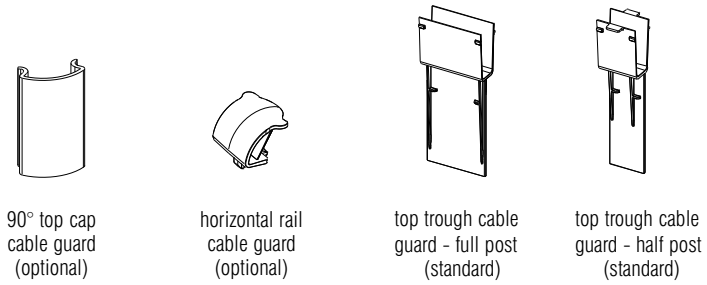
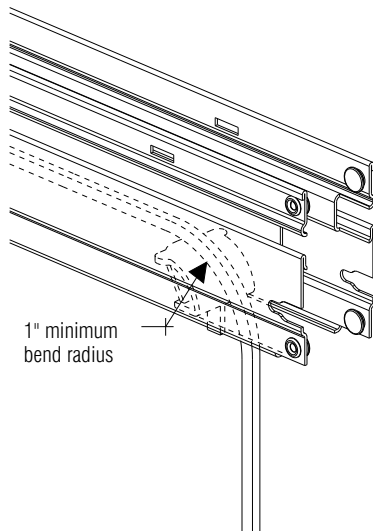

Figure 57



Detail N

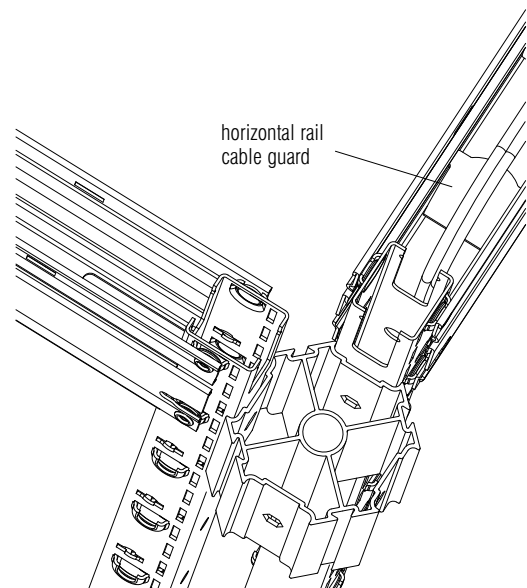

Figure 58

Data Cabling Behind Acoustic Tiles

Data cabling can be run behind acoustic tiles by using acoustic tile cable guards and horizontal cable supports.

Note: It is recommended that wires only be run behind tiles which you will have easy access to after the installation is complete. You will not be able to hang on-module mounted components in front of areas where data cabling has been run. Refer to the diagram on next page.

1. Install cable guards at the height you want to run the data cabling. Position the acoustic tile cable guard with hooks down and place the lowest hook in a slot in the vertical that corresponds to a pocket. Then push the guard down to flex the lower portion of it and pivot the upper hook into place. **Figure 59.**

Note: Each vertical cable guide behind an acoustical tile can hold a maximum of six, 0.20 dia. 4 pair, UTP data cables.

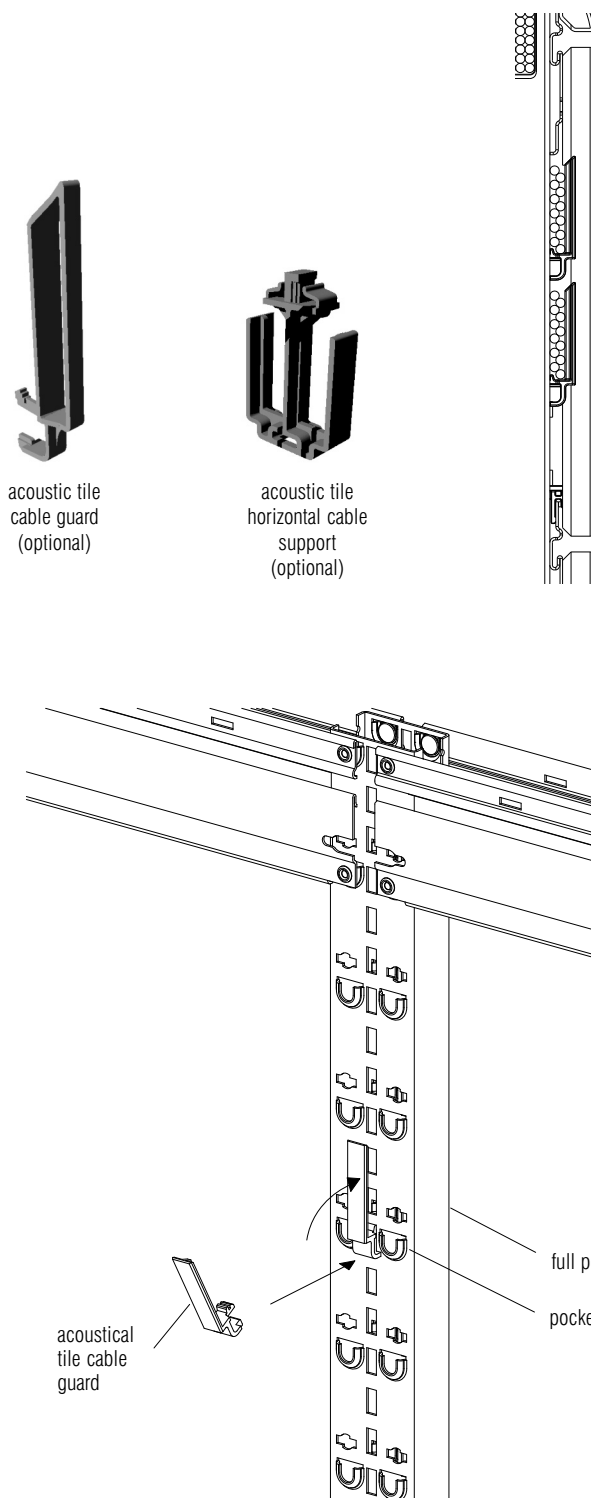
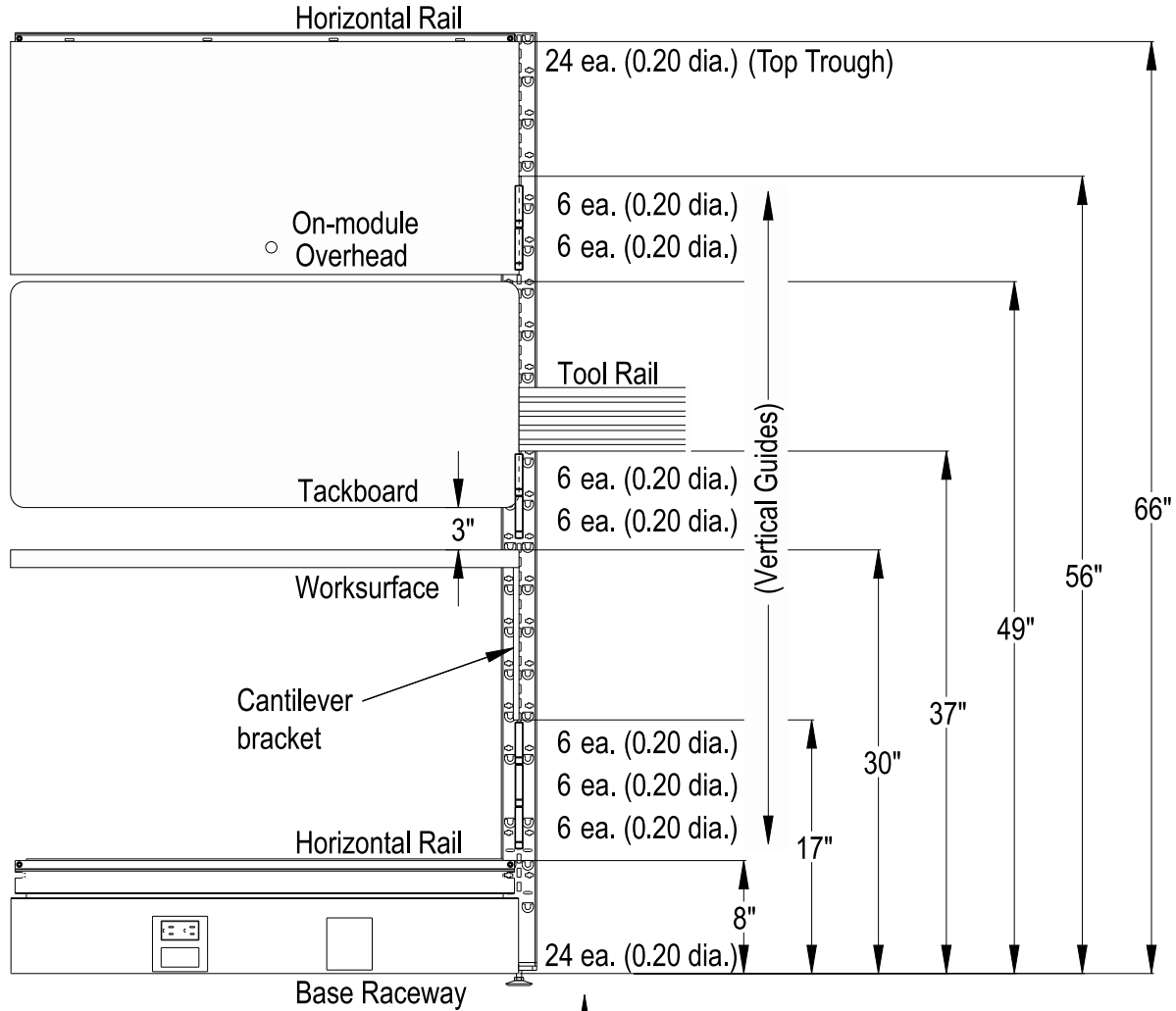

Figure 59

Data Cable Management



Number of cables accessible
at specific locations on each
side of a 66" tall monolithic tile.

Note: The maximum number
in top trough is 24 ea. (0.20 dia.)

Data Cabling Behind Acoustic Tiles (continued)

2. To support wires in the middle of larger panels, use an acoustic tile horizontal cable support. To install; align the rectangular projection on the top of the wire support with the rectangular hole in the horizontal. Push the wire support through the horizontal and rotate it one-quarter turn to lock it into place. If support is required for other wires, the wire supports can be ganged by using the rectangular hole in the bottom of the wire support. The method of ganging is identical to attaching to a horizontal rail. **Figure 60.**
3. When the necessary wire guards and supports are installed, lay the cabling in place behind the guards and supports. **Figure 61.**
4. Refer to table below for recommended cables behind each tile.

Acoustical Tile Height	Maximum # of Vertical Cable Guides
12"	2
18"	4
24"	6
30"	8
36"	10
42"	12
48"	14
54"	16
60"	18
66"	20
72"	22
78"	24

For example:

12" high acoustical tile can accommodate two vertical cable guides, each guide can hold 6 - 4 pair UTP .20 dia. cables for a total capacity of 12 ($2 \times 6 = 12$).

Lay-in cabling shall be supported throughout the panel. Cabling shall never be threaded through cutouts in frame. Panel horizontal rails shall be removable to allow for removal of vertically run cables within a panel.

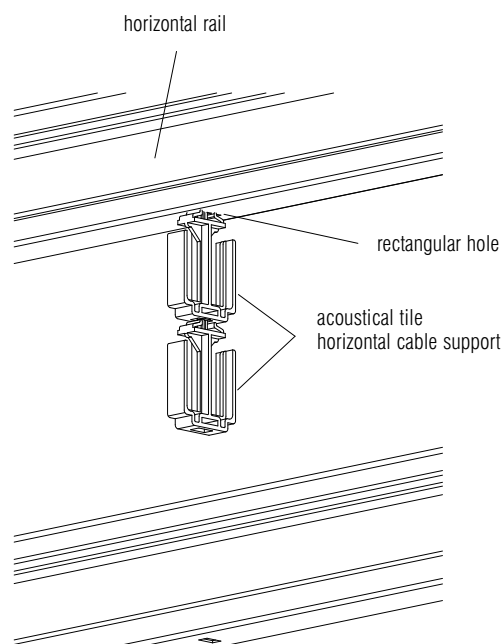

Figure 60

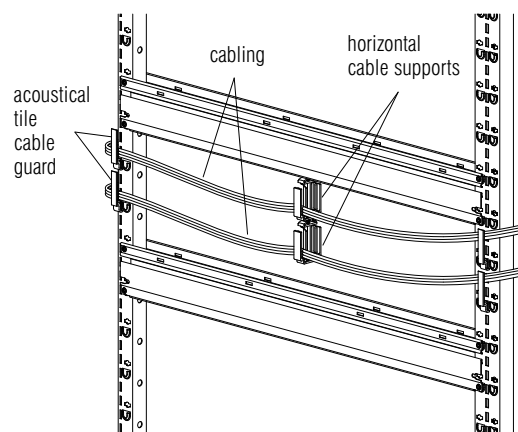

Figure 61

Data Cable Management

Data Cabling Behind Raceway Tiles

Every raceway tile includes a steel wiring trough to hold data cables and provide steel separation between power and data wiring.

A total of 24, 0.20 dia. 4 pair, UTP data cables can be routed in the cable trough behind a raceway tile. If a rigid wireway is not used, then two cable troughs can be utilized to allow a total of 48, 0.20 dia. 4 pair, UTP data cables behind the raceway tile. **Figure 62.**

1. Hang the trough in the slots in the vertical approximately 1" below the horizontal rail. This allows room for a rigid wireway and data jacks below the trough. Data cabling is simply laid into the trough. **Figure 63.** Troughs can be used back-to-back.

Note: If the trough is installed more than 1" below the horizontal, it will interfere with the bezel of the raceway tile.

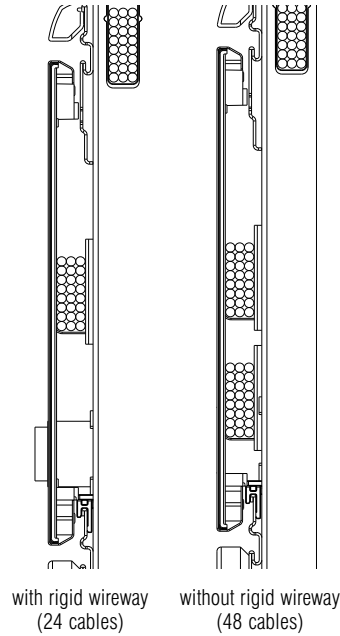

Figure 62

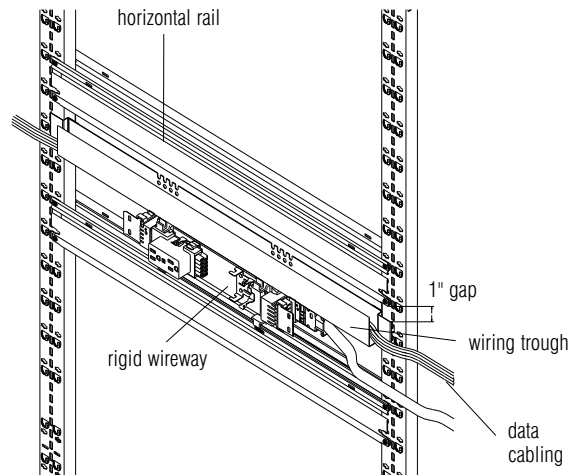

Figure 63

Data Cabling In The Base Raceway

Data cabling can be laid below the rigid wireway in the base raceway. An optional steel septum is available to provide separation between the power and data.

The base raceway with rigid wireway can hold 24, 0.20 dia. 4 pair, UTP data cables per side for a total of 48. Without a rigid wireway, the base raceway can hold 48 on each side for a total of 96.

1. To install the septum, position it between the vertical posts underneath the rigid wireway with the small bent tabs facing downward. The septum is slid up flush underneath the rigid wireway and held in place by the supplied self drilling and tapping screws. **Figure 64.**
2. Lay the cables in the raceway as required. **Figure 65.** Using one hand, close the raceway door and it will snap into place.

Vertical Data Cabling

Any data cabling laid into a horizontal rail or trough, can be routed to another height by running cabling vertically.

1. Run data cabling vertically through the notch in the end of a horizontal rail. Use a horizontal rail cable guard to enforce a 1" minimum bend radius. **Figure 66.**

Note: Horizontal rails can be added and removed with the cables in place (unless both notches of a horizontal rail are completely filled with cables). At least 24, 0.20 dia, 4 pair UTP data cables can be routed through each notch of a horizontal rail. Twenty four cables represents approximately 50% fill capacity of each notch.

Note: Filling both notches of the rail beyond 50% capacity can "trap" the horizontal rail in place, making it difficult to reconfigure a panel without disturbing the cables.

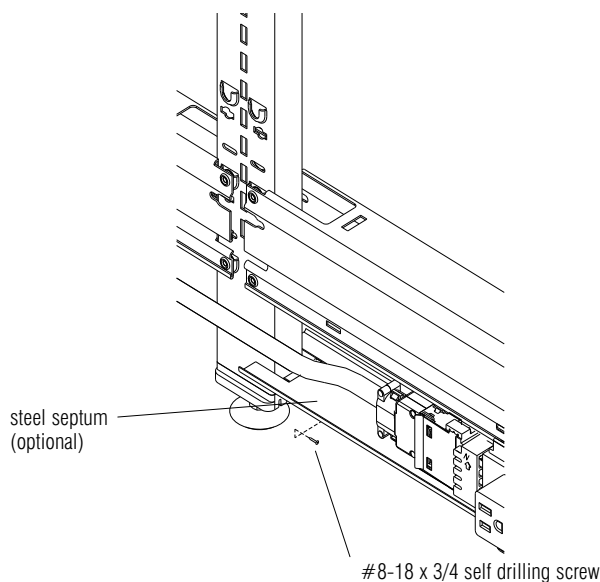
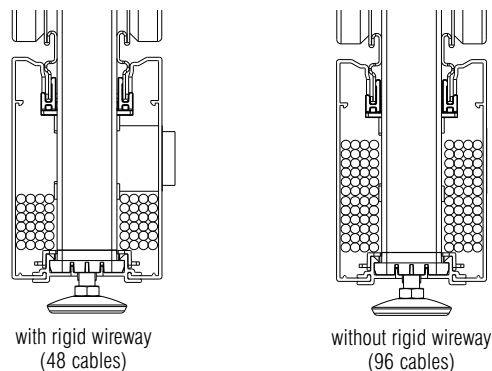

Figure 64

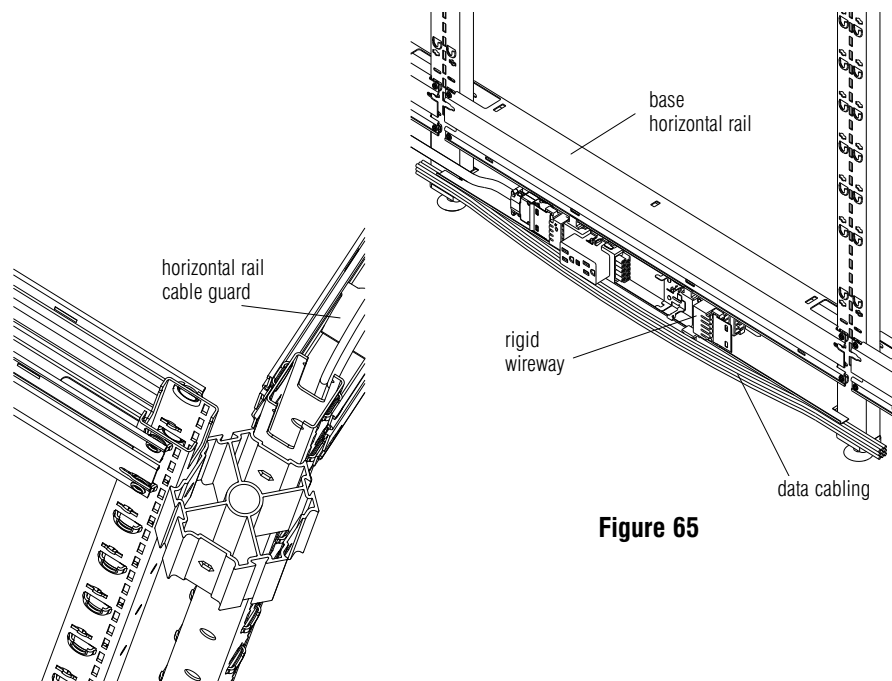

Figure 65

Figure 66

Data Cable Management

Storing Extra Data Cables Inside Of Panel

Extra data cabling can be stored inside of panels behind tiles.

Extra cable loops can be hung from an unused acoustical tile horizontal cable support. **Figure 67.**

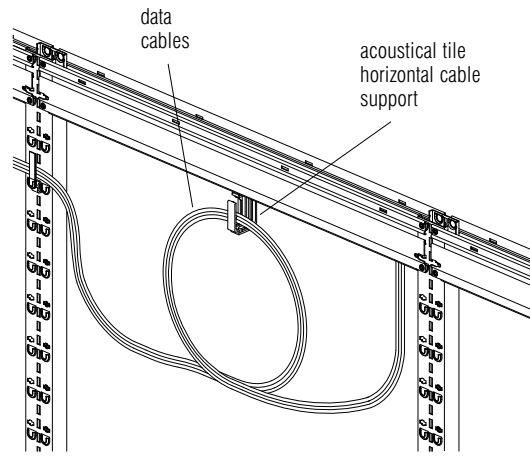

Figure 67

Hanging Acoustical Tiles

Acoustical tiles have slots in the back to accept the tile hooks.

1. With the tile hooks already in place on the frame (See **Installing Tile Hooks on page 13**), hang the tile on the top two hooks. **Figure 68.**
2. Hold the top of the tile against the frame and gently lift up on the bottom of the tile while pushing it in toward the frame to engage the bottom hooks. Let the tile slide down into position while continuing to support it against the frame. **Figure 69.**
3. After the tile is hung, pull the tile away from the frame on all corners to ensure that all four hooks are engaged.

Note: Tiles can be rotated and still hung on the panel frame. For example, a 24" x 24" tile can be hung with any edge as the top. When fabrics are directional, you must orient the tile correctly to achieve the correct visual appearance. All tiles have the size marked on the back of the tile. This mark is along the edge that the factory considered the top while the tile was being upholstered.

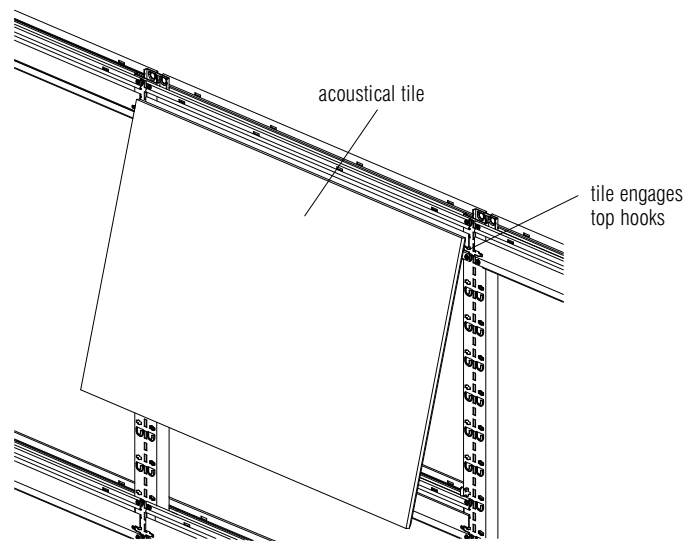

Figure 68

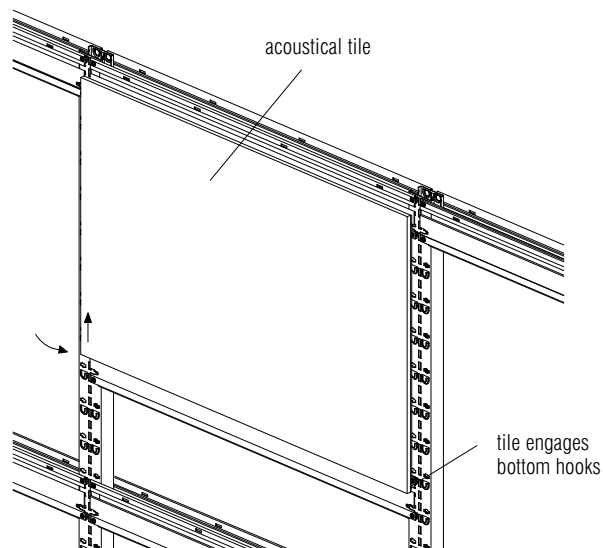

Figure 69

Tile Installation

Hanging Raceway Tiles

Raceway tiles have molded-end pieces to hang onto the tile hooks.

Note: Raceway tiles may be used to cover belt height power passthru and not used for receptacles. These tiles would require two filler plates and one bezel per opening.

Note: Raceway tiles 24" and wider come with a knock-out for electrical and/or data.

1. Snap the receptacle/data bezel into the knock-out to cover the edge of the fabric.

Note: Ensure that bezel is installed with the correct end up. Refer to directions on inside of bezel.

2. With the tile hooks already in place on the frame (See **Installing Tile Hooks on page 13**) and the wire trough installed (see **page 40**), hang the raceway tile on the top two hooks. **Figure 70.**
3. Apply firm consistent pressure to the lower corners of the raceway tile until the tile snaps into place. **Figure 71.** The lower hooks on raceway tiles are engaged by a snapping action.

Note: Raceway tiles are removed by swinging bottom of tile out and away from bottom hooks before lifting tile up off of top hooks.

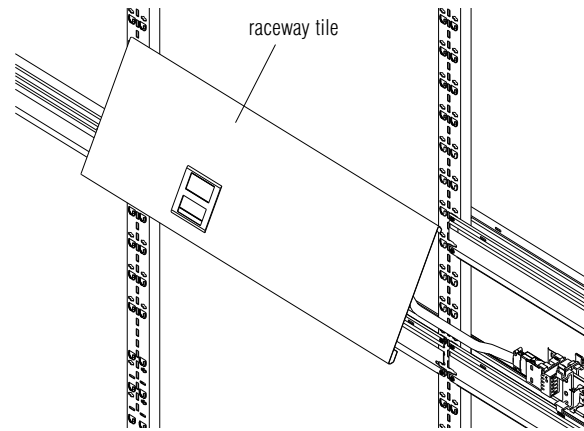

Figure 70

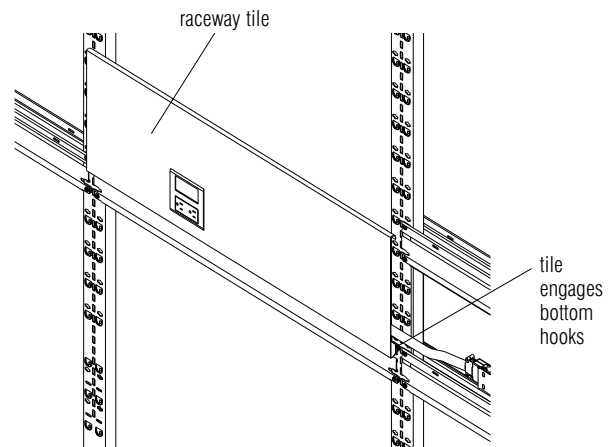

Figure 71

Hanging Open and Window Tiles

Open and window tiles consist of two separate tiles that hang back-to-back. The first tile either supports the glass on a window tile or a thin plastic extrusion for the open tile. The second tile is the same for the window and the open tile and consists of a painted aluminum trim frame.

Both halves of the open and window tiles are hung like acoustic tiles, except eight hooks are used per side instead of four. The extra hooks are installed just above the lower two hooks and just below the upper two hooks.

1. With the tile hooks already in place on the frame (See **Installing Tile Hooks on page 13**), hang the tile on the top four hooks. **Figure 72.**
 2. Hold the top of the tile against the frame and gently lift up on the bottom of the tile while pushing it in toward the frame to engage the hooks. Let the tile slide down into position while continuing to support it against the frame. **Figure 73.**
 3. After the tile is hung, pull the tile away from the frame on the four corners to ensure that all eight hooks are engaged.
 4. Install each supplied dislodgment insert into the horizontal above the window using a #3 Phillips head screwdriver. **Figure 74.** Two inserts are used per window or open tile.
- Note:** Tiles can be rotated and still hung on the panel frame. For example, a 24" x 24" tile can be hung with any edge as the top.
5. Enhanced horizontals have holes to allow access to the dislodgment insert. **Detail 0.**

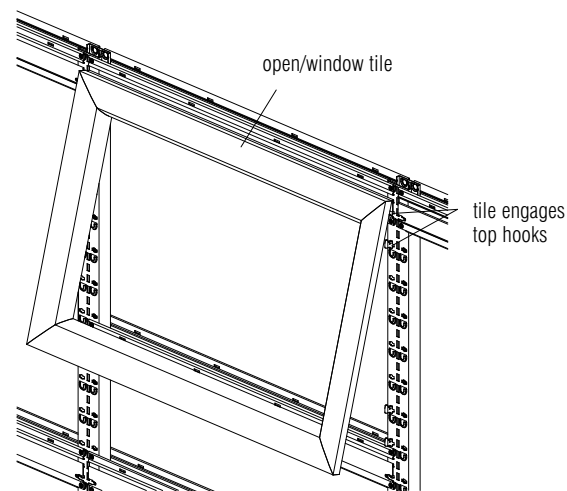

Figure 72

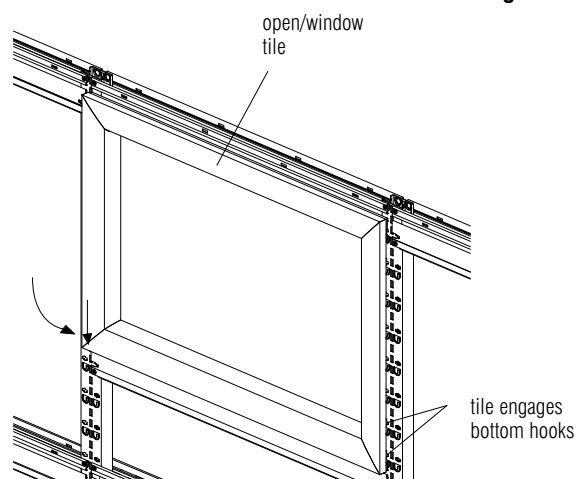

Figure 73

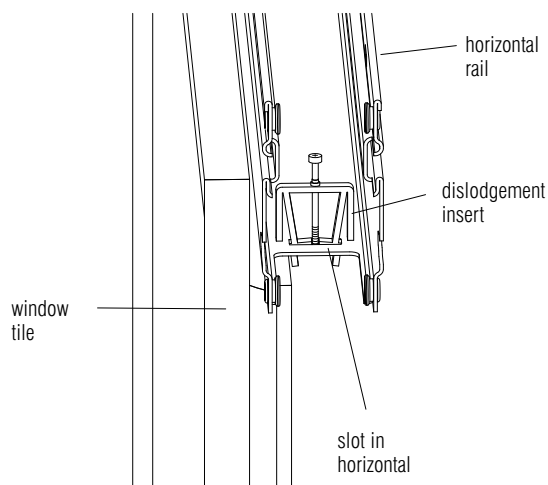
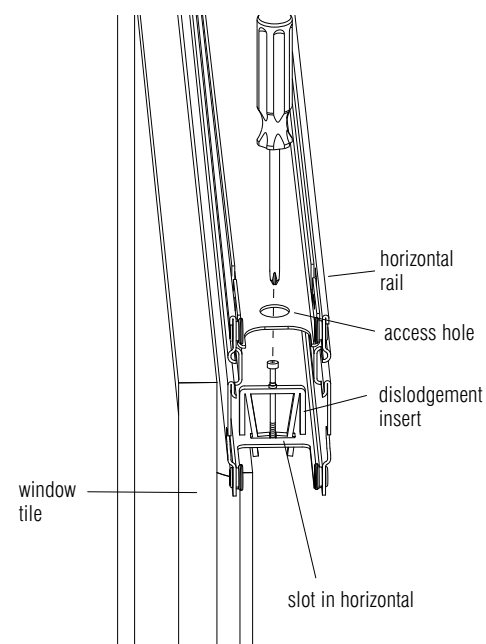

Figure 74



Detail 0

Trim Installation

Installing Top Caps

Top caps snap over the top horizontal rail and are the same width as the panel.

1. Align the cap over the top horizontal rail and firmly snap it down into place. **Figure 75.**
2. When top caps are adjacent to each other, slide the supplied top cap splice plate between the top caps to help keep them properly aligned. **Figure 76.**

Hint: To remove top caps, press down in the center of the cap while lifting up on the edge.
Detail P.

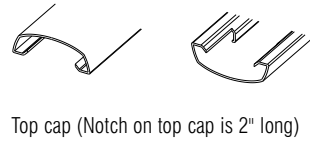

Top cap (Notch on top cap is 2" long)

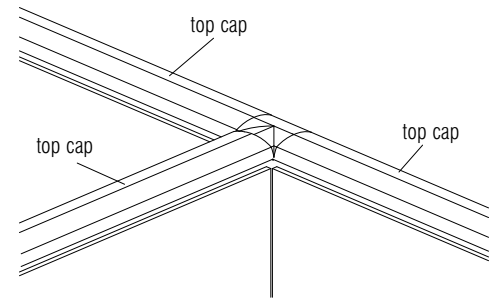
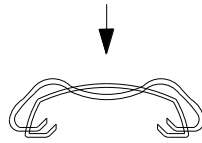

Figure 75



Detail P

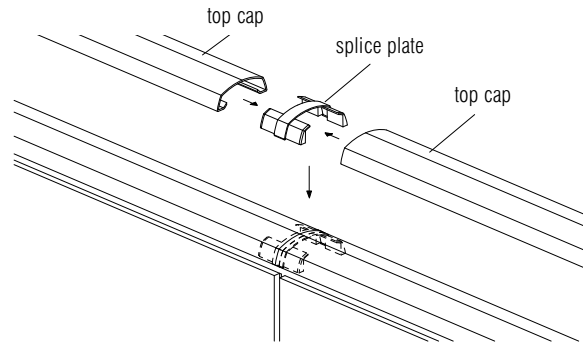
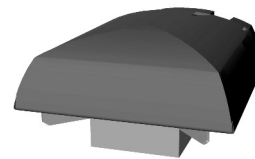
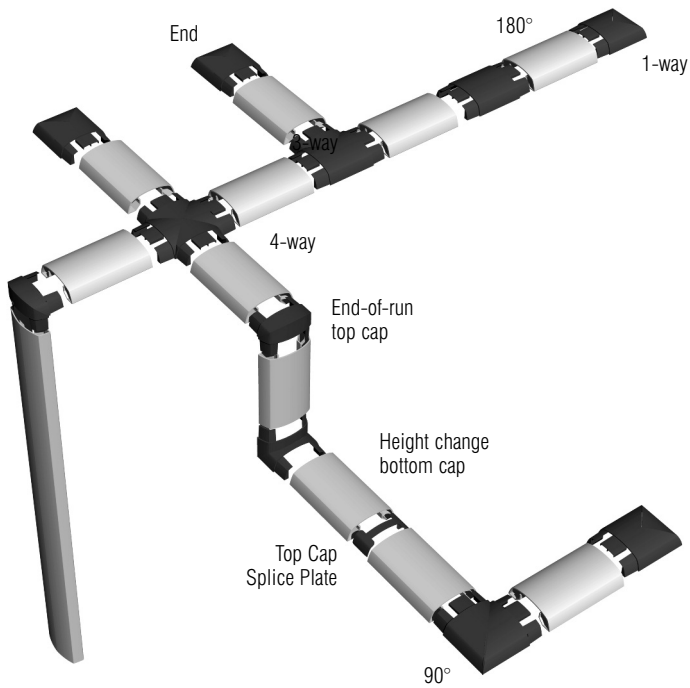
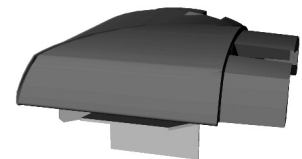

Figure 76



One-Way Top Cap



90° Top Cap

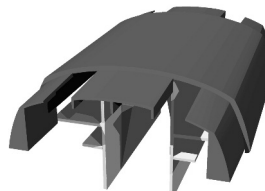

180° Top Cap

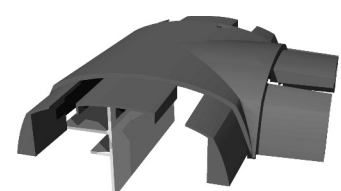

Three-Way Top Cap

Note: When top cap is installed, make sure the light block is attached as depicted in the above drawings. See page 5, Figure 2.

Installing End-Of-Run Trim

End-of-run trim is installed over the exposed portion of a full post in an end-of-run condition and is the same height as a panel.

Note: Each end-of-run includes a top cap.

1. Install end-of-run top cap into the end-of-run trim. A "To Floor" note is molded into the inside of the top cap.
2. Push the end-of-run trim with top cap onto the full post. Ensure that the notch at the bottom of the trim rests on the lip of the glide housing. **Figure 77.**

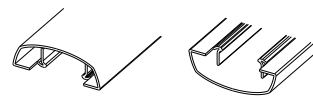

End-of-run trim (Notch on end of run is 1/2" long)

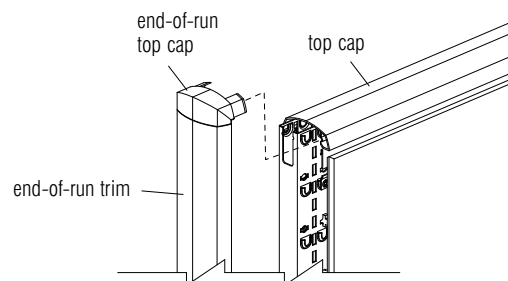

Figure 77

Installing Universal Corner Trim

90° corner and 3-way intersections use universal trim to finish the corner. A 90° corner uses two pieces of universal trim and a 3-way intersection uses one piece.

1. Position the universal corner trim over each corner connector and firmly snap it into place. **Figure 78.**

Note: To remove universal trim from corner connectors, remove the top cap from the horizontal rail, slide the universal trim up approximately 18" past the corner connector and twist to detach. **Detail Q.**

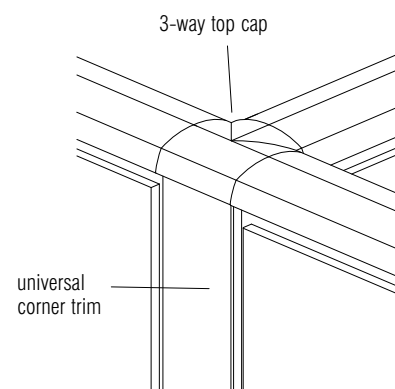
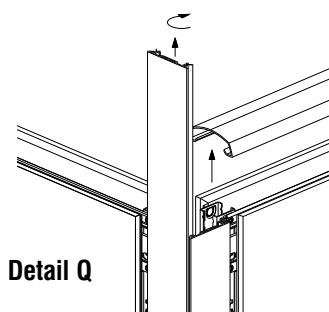

Figure 78



Detail Q

Trim Installation

Installing Universal Height Change Trim

Height change trim is the same as universal trim with a small notch in the bottom. These trim pieces are used to fill in between panels of two different heights.

1. Orient the notch downward and snap the trim over the exposed portions of the connector block. **Figure 79.**

Note: Face the opening of all height change connector blocks toward the shortest panel to allow for lay-in wire management. **Detail R.**

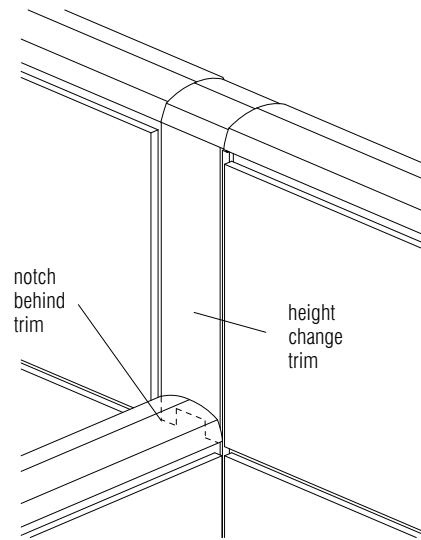
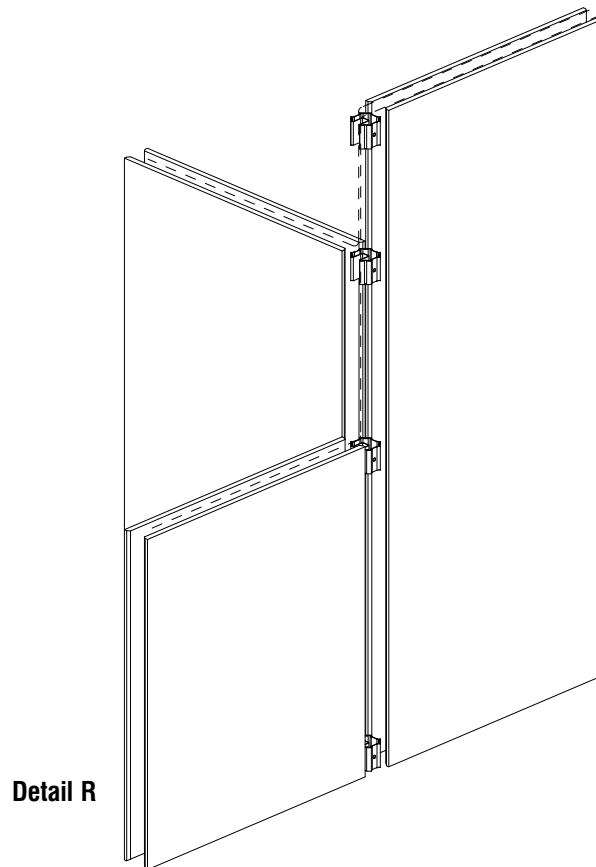

Figure 79



Detail R

Installing In-Line Height Change Trim

In-line height change trim is installed over the exposed portion of a full post in an in-line height change condition.

1. Remove the lower top cap in the intersection and trim the required amount from its length. Replace the trim.

Hint: Use miter box to ensure a straight cut.

Note: The installation of height change trim requires that the adjacent lower top cap trim be shortened by either 2" or 4", depending on the application. **Figure 80.**

2. Snap the in-line height change trim into place over the full post. **Figure 81.**

Note: Face the opening of all height change connector blocks toward the shortest panel to allow for lay-in wire management. **Detail S.**

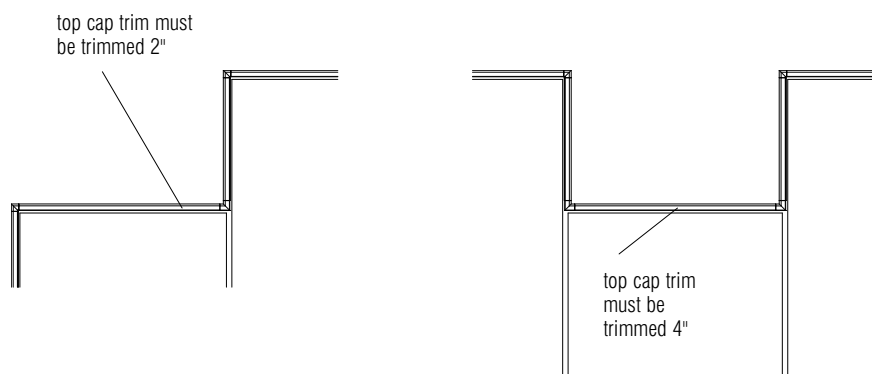
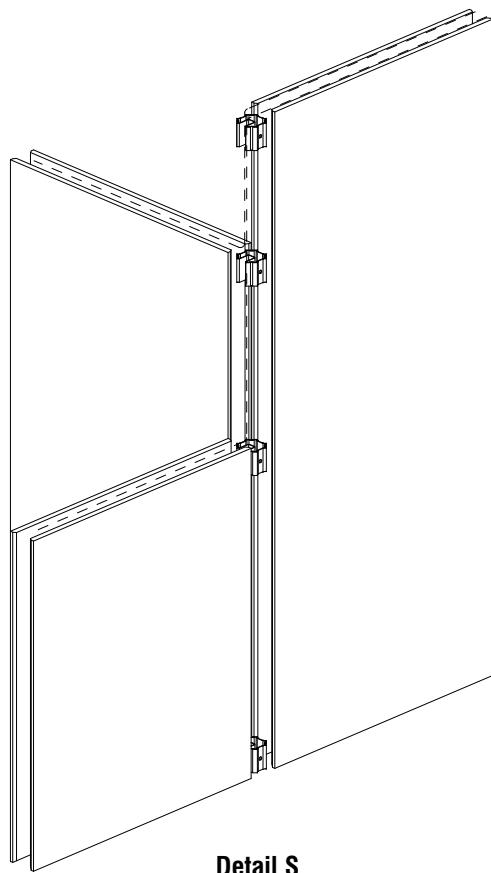

Figure 80

Note: In this case notch orientation does not matter



Detail S

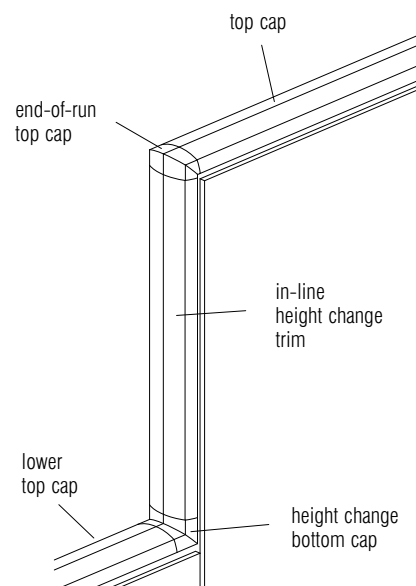

Figure 81

Reconfiguration

Adding and Removing Horizontals

Horizontal rails can be added and removed without disturbing adjacent verticals or wiring. This allows the user to convert a panel from monolithic to tiled with minimal disruption. This can be useful for adding power at different heights or setting up a panel for use with an off-module overhead.

Warning: Do not remove the top or bottom horizontal of a panel if there are load-bearing components mounted to it or an adjacent panel. The panel can only support loads if both the top and bottom horizontal are properly installed.

Warning: Use caution when disassembling both the bottom and the top horizontal of a panel. If there are not returns attached to both sides of the resulting panel run, the panels will not be able to support themselves.

1. After removing the required tile(s), remove the horizontal rail by taking off any tile hooks that are locking the horizontal in place. Then, tap the horizontal out with a dead blow mallet. Once the horizontal is free from the pockets on the vertical post, lift the horizontal up and slide it to one side. Rotate the opposite side upward to clear the vertical post, and lift the horizontal free. **Figure 82.**

Note: There is not enough clearance to utilize a mallet to remove the lowest horizontal, so a special slot is included in the vertical which allows a screwdriver to be used to lever the horizontal out. Position the 3/8" flat blade screwdriver at a downward angle and insert it through the off module slot area and into the oval hole. Pry up with the screwdriver to release the horizontal. **Figure 83.**

Warning: Do not use the slot reserved for the tile hooks to remove horizontals. This will damage the surrounding steel and may make it impossible to properly install tiles in the future.

2. Horizontals are added by positioning the horizontal at any angle between vertical posts and sliding one end around a vertical at the desired height. Then, rotate the horizontal downward, centering with the rivets above the pocket on the post. When all rivets are properly aligned, tap the horizontal into place with a mallet. **Figure 84.**

Warning: Be sure all rivets engage in the pockets of the post properly.

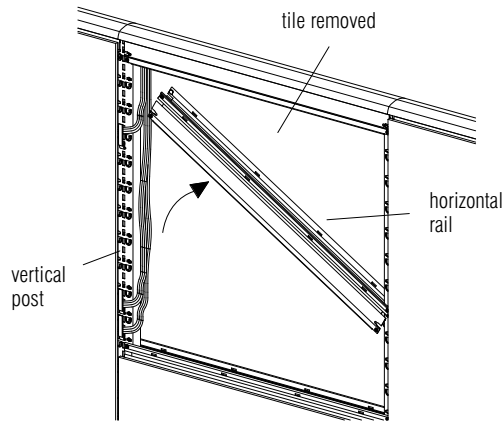

Figure 82

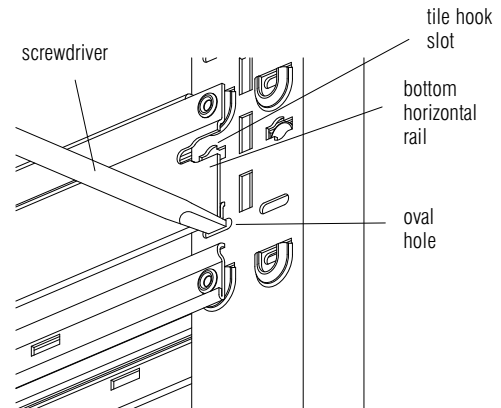

Figure 83

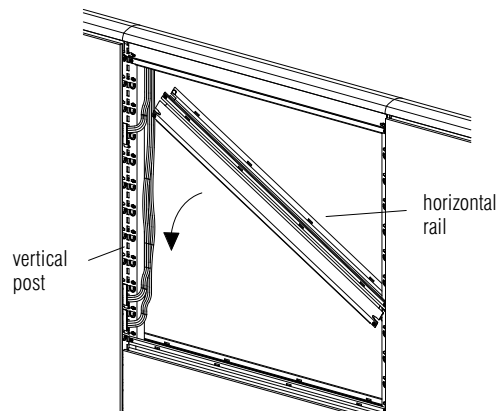

Figure 84

Stacking Vertical Posts

Stacking vertical posts come in 12", 18", and 24" heights for both full and half posts. Using stacking posts, you can add height to panels already installed. Please note that there are restrictions to how stacking sections can be used with load-bearing components. Refer to the Planning Guide for more information.

1. Install a stacking section by first removing the top cap, any wires from the top of the vertical post and the top light block.
2. Position the stacking splice above the top of the vertical post and tap into place. Do not damage top of stacking splice during installation. Continue adding stacking sections as required. **Figure 85.**

Note: When installing half post stacking sections, be sure the vertical slots in the stacking post are aligned with the slots in the post beneath it.

3. After the necessary stacking sections are in place, add the necessary horizontal rails, tile hooks, tiles and trim to complete the installation. **Figure 86.**

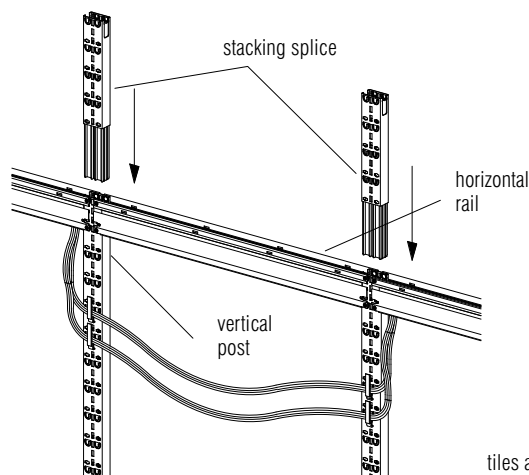

Figure 85

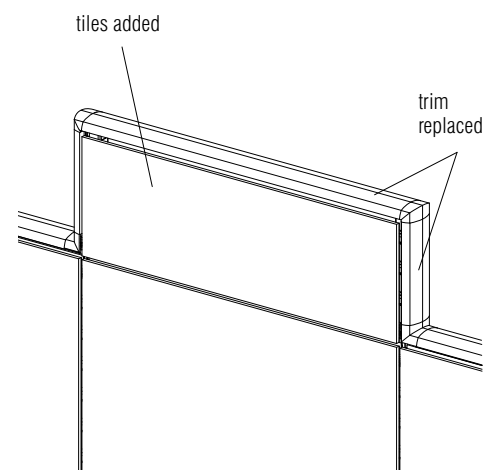

Figure 86

Adding Intersections

PowerWorks panels are designed with modular trim at the intersections.

1. Add another panel to an intersection by simply removing the universal trim that is covering the side to which you will be adding another panel run. **Figure 87.**
2. Bolt a new half post into the connector block and continue to install the additional panels as described in the previous sections. **Figure 88.**

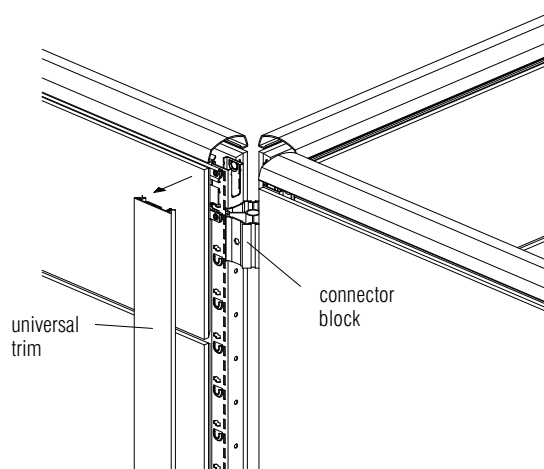

Figure 87

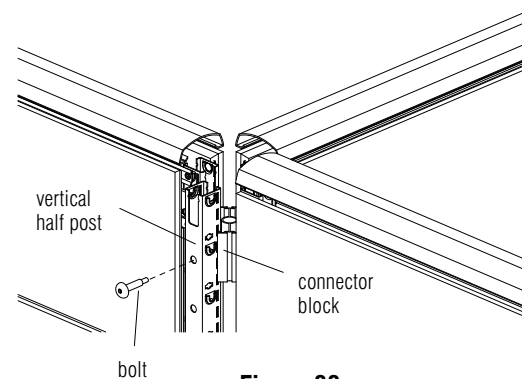

Figure 88

Specification Guidelines

Unloaded Panel Runs

For unloaded panel runs, the maximum length of a run is 12' and the return panels must be at least 48" wide and within 18" in height of the main run of panels. Panels may be stacked to a maximum height of 12' and must remain below the height of the ceiling, but the returns must remain within 18" in height of the main run. Any combination of glass, open, or acoustic panels is allowed.

Unloaded Panel Runs Starting With Wall Mounts



Return panel must be equal to, or within 18" of the height of the main panel run.

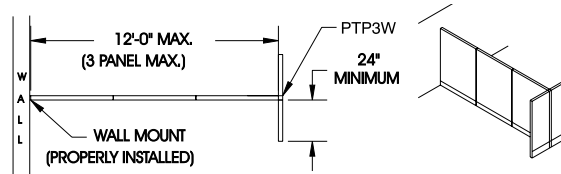

Return panels can be any height when they return in opposite directions as shown at left.

Unloaded Freestanding Runs With Returns At Both Ends

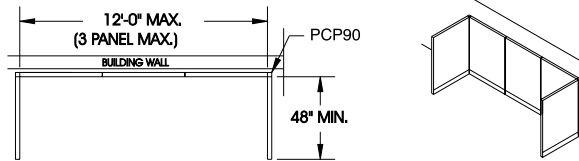

Return panel(s) must be equal to, or within 18" of the height of the main panel run, UNLESS the main panel run is tight against a building wall. If the main run is tight against the building wall, the return panels can be any height.

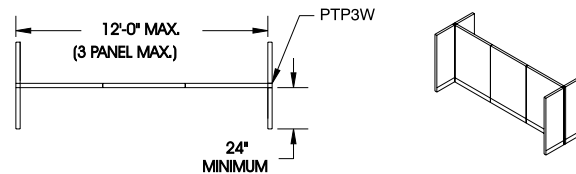

Return panels can be any height when they return in opposite directions as shown at left.

Stacking Section Guidelines

Use the following specifications when applying stackable sections. Stackable sections must always remain below the ceiling. Multiple stacking sections must begin with a standard non-stacked vertical post. To stack on top of a fully assembled panel, at least 7" of clearance should be left between the top of the panel and the ceiling. If less clearance is available, the panel frame must be disassembled before adding or removing stacking sections.

Load Bearing Applications

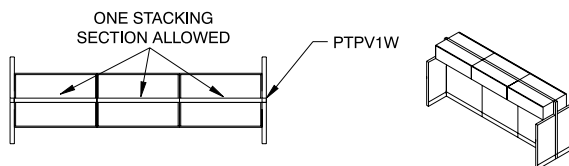

Stacking sections are designed to be load bearing, however, only one stacking section is allowed at or below the height of the load bearing components. Unloaded return panels can utilize any number of stacking sections.

Non-Load Bearing Applications

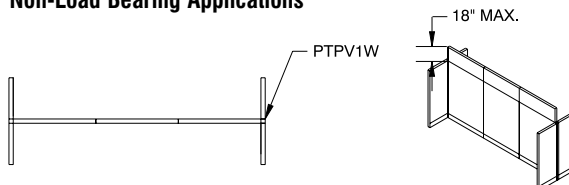

When panels will not be bearing loads, any number of stacking sections may be used, however, you still must keep return panels within 18" in height from the main run for stability reasons. Panels can be stacked to a maximum height of 12' and must be below the ceiling.

Return Panel Guidelines

Definition of Return: A panel or combination of panels that has one of its ends connected to a run of panels while the other end is unsupported.

- Cannot exceed a total length of 8'
- Cannot consist of more than two panels
- Cannot support overhead storage
- Cannot support worksurfaces or countertops

Rules:

- Any return between 48" and 96" in length requires enhanced horizontals.
- Any return greater than 48" requires enhanced horizontals on both panels that make up the return.
- Two enhanced horizontals are required per panel, one at the top and the other at the bottom.

Examples: Where needed

This combination of two panels is wider than 48", therefore both panels require Enhanced Horizontals.

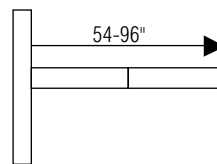

This single panel is wider than 48", therefore requires Enhanced Horizontals.

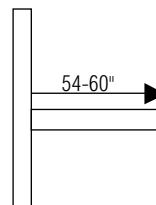

This combination of two panels is adjacent to a worksurface, but still requires Enhanced Horizontals in both panels.

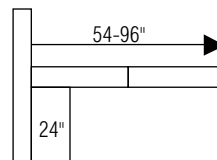

This combination of two panels attaches the adjacent worksurfaces to a panel with a worksurface support bracket (WSB), but still requires Enhanced Horizontals in both panels.

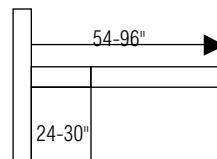

810 Universal Electrical

Power Infeed to Building Connections

Have a certified electrician hard-wire the panel power infeed to the building power source according to the National Electrical Code and any other applicable local codes. See the chart for proper wiring connection to available power.

6-2-2		
Receptacles available	Wires to be used	Gauge of wire
Circuit 1	Black White/Black Letters Green or Bare	12 10 12
Circuit 2	Red White/Black Letters Green or Bare	12 10 12
Circuit 3	Blue White/Black Letters Green or Bare	12 10 12
Circuit 4	Pink White/Red Letters Green/Yellow Stripe or Gray	12 10 12
Circuit 5	Tan White/Red Letters Green/Yellow Stripe or Gray	12 10 12
Circuit 6	Orange White/Red Letters Green/Yellow Stripe or Gray	12 10 12

6-2-2 CONNECTION DIAGRAMS

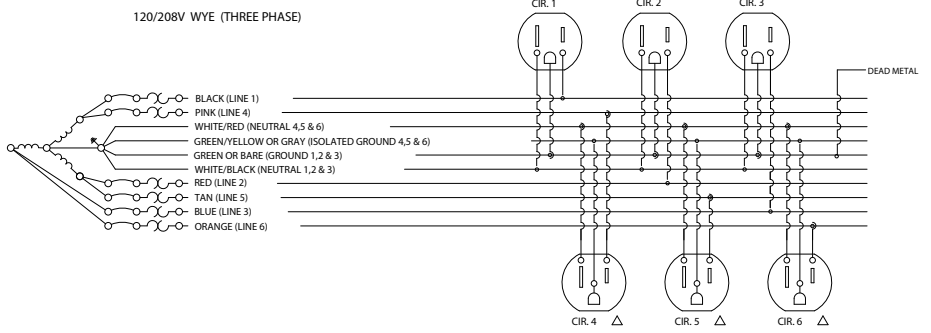
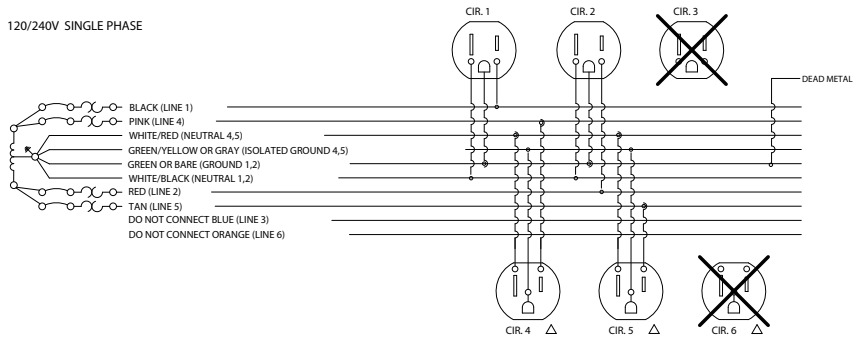

6-2-2 CONNECTION DIAGRAMS TO AN 8-WIRE BUILDING

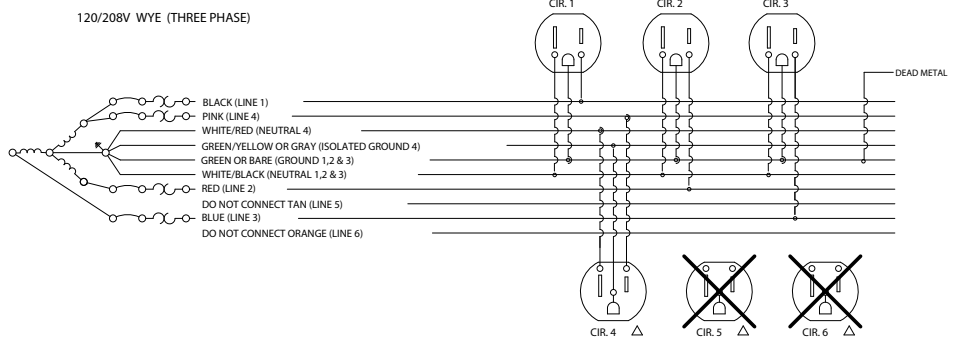
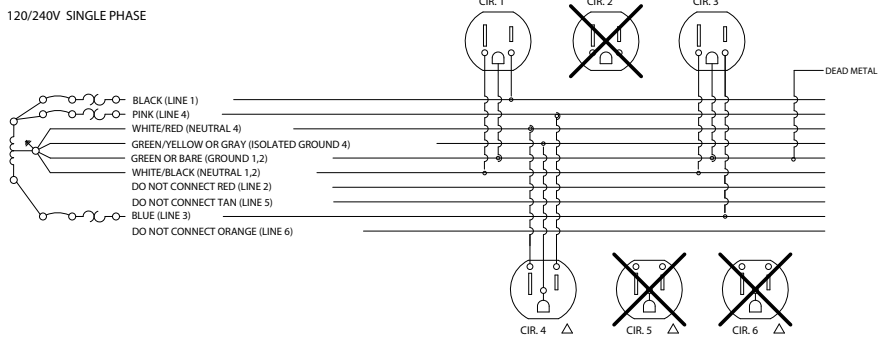

Power Infeed to Building Connections

Have a certified electrician hard-wire the panel power infeed to the building power source according to the National Electrical Code and any other applicable local codes. See the chart for proper wiring connection to available power.

4-4-2

Receptacles available	Wires to be used	Gauge of wire
Circuit 1	Black White/Black Letters Green or Bare	12 12 12
Circuit 2	Red White/Black Letters Green or Bare	12 12 12
Circuit 3	Blue White/Black Letters Green/Yellow Stripe or Gray	12 12 12
Circuit 4	Pink White/Purple Letters Green/Yellow Stripe or Gray	12 12 12

4-4-2 CONNECTION DIAGRAMS

120/240V SINGLE PHASE

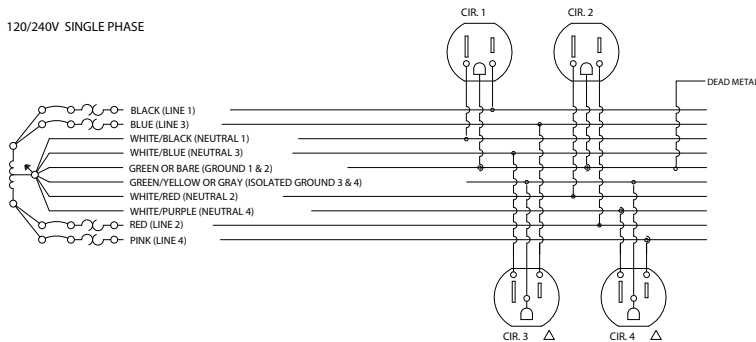

120/208V WYE (THREE PHASE)

