

POWERWORKS®

PANEL SYSTEM

product offering catalog



Effective February 2020

PowerWorks®	Product Color Options	2	Universal Storage and Accessories	Overhead Storage	100
				Overhead Accessories & Task Light	107
Fabric Panel - Tackable Acoustic - 3/4" Thick Tiles	Face Styles	6	Universal & Venus® Accessories	Tuck LED Task Light	110
				REED LED Task Light	112
Fabric Panel - Tackable Acoustic - 3/4" Thick Tiles	Monolithic Panel	10	Venus® Storage and Accessories	General Information	113
	Monolithic/Half Segmented Panel	12		Overhead Storage	114
	Monolithic/Fully Segmented Panel	14		Overhead Accessories	120
	Half Segmented/Half Segmented Panel	16		Overhead Task Light	123
	Half Segmented/Fully Segmented Panel	18	Accessories	Markerboards	124
	Fully Segmented/Fully Segmented Panel	20		Tackboard	125
Glass Panel	Face Styles	22		Brackets	128
	Full Glass Panel	24		Paper Management	129
				Desktop Accessories	130
Glass/Fabric Panel - Acoustic - 3/4" Thick Tiles	Monolithic/Monolithic/Glass Panel	25	120° Intersections	2-Way	132
	Monolithic/Fully Segmented/Glass Panel	26		3-Way	135
	Fully Segmented/Fully Segmented/Glass Panel	28		2-Way and 3-Way Stackable	140
Open Panel	Face Styles	30	120° Worksurfaces	Corner Worksurfaces	141
	Full Open Panel	32	Tech Preconfigured Intersection Conditions	90° 2-Way and End-of-Run	142
				90° 2-Way	143
Open/Fabric Panel - Acoustic - 3/4" Thick Tiles	Open/Monolithic/Monolithic Panel	34		180° 2-Way	147
	Monolithic/Monolithic/Open Panel	36		3-Way	150
				4-Way	153
Fabric Stackable Section - Acoustic - 3/4" Tiles		38		Tech Panel Components	156
Glass Stackable Section		39	Universal Electrical Connection Diagram	4-4-2	158
Open Stackable Section		40		6-2-2	159
Doors		42	PowerWorks® C.O.M. Yardage Requirements		160
Preconfigured Intersection Conditions	90° 2-Way and End-of-Run	44			
	90° 2-Way	45			
	Off-Module Post	49			
	Adjustable Wall Mount	50			
	180° 2-Way	51			
	3-Way	56			
	4-Way	63			
Preconfigured Stackable Intersection Conditions	180° 2-Way and End-of-Run	70			
	2-Way and 3-Way	71			
	2-Way, 3-Way and 4-Way	72			
Electrical	10-Wire System 6 Circuit "810"	74			
	10-Wire System 4 Circuit "810"	80			
Cable Management		86			
Worksurfaces	Rectangular	88			
	"P" Shaped Peninsula/Piano Peninsula	89			
	Square Shoe/Conference End	90			
	"D" Shaped Peninsula	91			
	Dual Curvilinear/Diag/Curvilinear 90° Corner	92			
	Countertops	93			
	Mobile Teardrop/Mobile Semi-Circle	94			
	Worksurface Support Panel	96			
Worksurface Accessories	Worksurface Accessories	98			

PowerWorks®

Product Color Options

Panels/Doors - Trim Color

Black	BL
Blue Grey	GR
Cool Grey	CG
Light Tone	LG
Misty Brown	MY
Sand	SA
Starlight Silver Metallic	SX
Warm Grey	WG

Starlight Silver is available on aluminum trim pieces only.

Panels/Doors - Glass Color

Tinted/Bronze	BRZ
Clear	GLA
White laminate	GLC

Glass color selection available on glazed panels only.

Doors/Worksurfaces/Universal & Balance® Overhead/120° Worksurfaces/Worksurface Accessories - Surface Finish-Laminate

Biltmore Cherry	LBT
Black	LBK
Brighton Walnut	LBW
Canyon Zephyr	LCA
Castle Oak	LCO
Casual Linen	LCU
Cherry Storm	LCX
Classic Linen	LCI
Cloud Zephyr	LCL
Cocobala	LCC
Coffee Bean	LCB
Crisp Linen	LRI
Desert Zephyr	LDZ
Dove Grey	LDG
Fired Steel	LIL
Flax Linen	LXF
Florence Walnut	LFC
Forged Steel	LOL
Frosty White	LFW
Graphite Nebula	LGN
Grey	LGE
High Rise	LHE
Hollyberry	LHY
Irish Linen	LIH
Island	LID
Italian Silver Ash	LIT
Kensington Maple	LKM
Lapis Blue	LLB
Markerboard White	LMK
Misted Zephyr	LMR
Monticello Maple	LMT
Nickel Evolv	LNV
North Sea	LNA
Ocean	LON
Orange Grove	LOE
Pearl Bisque	LPB
Pearl Silver	LPS
Pressed Linen	LPR
River Cherry	LRV
Rugged Linen	LRG
Satin Stainless	LSS
Shadow Zephyr	LSR
Silicon evolv	LSV
Sterling Ash	LAZ
Tailored Linen	LTL
Titanium evolv	LTV
White Nebula	LWL
White Sand	LWN
Windsor Mahogany	LWY

Preconfigured Intersections - Trim Color

Black	BL
Blue Grey	GR
Cool Grey	CG
Light Tone	LG
Misty Brown	MY
Sand	SA
Starlight Silver Metallic	SX
Warm Grey	WG

Starlight Silver is available at an upcharge on aluminum trim pieces only.

Electrical - Trim Color

Black	BL
Blue Grey	GR
Cool Grey	CG
Light Tone	LG
Misty Brown	MY
Sand	SA
Starlight Silver Metallic	SX
Warm Grey	WG

Trim color includes electrical bezel and worksurface edge (BN and 74P edge styles), grommet and support bracket color.

Electrical - Receptacle Color & Plastic Trim - Trim Color

Black	BL
Blue Grey	GR
Cool Grey	CG
Light Tone	LG
Misty Brown	MY
Sand	SA
Warm Grey	WG

Electrical - Exposed Infeed Coating

Black	BL
Blue Grey	GR
Cool Grey	CG
Light Tone	LG
Misty Brown	MY
Sand	SA
Warm Grey	WG

Worksurface/Universal Overhead - Veneer Wood Finish & Wood Edge Finish Laminate & Veneer

Cherry Storm on Maple	MCX
Cinnamon on Maple	MCN
Cocoa on Maple	MCA
Florence Walnut on Maple	MFC
Kensington Maple on Maple	MMA
Monticello Maple on Maple	MMT
River Cherry on Maple	MRY

Worksurfaces - Trim Color

Black	BL
Blue Grey	GR
Bronze Metallic	ZM
Cayenne	CY
Champagne Metallic	CM
Cool Grey	CG
Cottonwood	CO
Espresso Metallic	EX
Flannel	FN
Light Tone	LG
Misty Brown	MY
Nordic	ND
Sand	SA
Splash	SH
Starlight Silver	SX
Warm Grey	WG
Wet Sand	WS

Trim color is support bracket color.

Worksurfaces - Grommet Color

Black grommet	GBL
Blue Grey grommet	GGR
Cool Grey grommet	GCG
Light Tone grommet	GLG
Misty Brown grommet	GMV
Sand grommet	GSA
Warm Grey grommet	GWG

Includes Countertops with Notch Location.

Worksurfaces - Edge Color for BN Edge

Black	EBL
Blue Grey	EGR
Cool Grey	ECG
Flannel	EFN
Frosty White	EFW
Light Tone	ELG
Misty Brown	EMY
Sand	ESA
Sterling Ash	EAZ
Warm Grey	EWG
Wet Sand	EWS

Worksurfaces - Edge Color for 74P

Biltmore Cherry	EBT
Black	EBL
Blue Grey	EGR
Brighton Walnut	EBW
Castle Oak	ECO
Cherry Storm	ECX
Chocolate	ECT
Cocobala	ECC
Cool Grey	ECG
Flannel	EFN
Florence Walnut	EFC
Frosty White	EFW

Italian Silver Ash	EIT
Kensington Maple	EKM
Light Tone	ELG
Misty Brown	EMY
Monticello Maple	EMT
Multiplex	EMB
River Cherry	ERY
Sand	ESA
Sterling Ash	EAZ
Warm Grey	EWG
Wet Sand	EWS
Windsor Mahogany	EWY

Universal Overhead - Paint Color

Black	BL/HBL
Blue Grey	GR/HGR
Bronze Metallic	ZM/HBL
Cayenne	CY/HBL
Champagne Metallic	CM/HLG
Cool Grey	CG/PCG
Cottonwood	CO/HSA
Espresso Metallic	EX/HBL
Flannel	FN/HBL
Light Tone	LG/HLG
Misty Brown	MY/PMY
Nordic	ND/HBL
Sand	SA/HSA
Splash	SH/HLG
Starlight Silver Metallic	SX/HWG
Warm Grey	WG/
HWG	
Wet Sand	WS/HSA

Metallic paint is available on aluminum trim pieces only.

Universal overhead door handle trim color automatically coordinates plastic color from the following: Black (BL), Blue Grey (GR), Light Tone (LG), Sand (SA), Warm Grey (WG) trim color coordinate based on paint color.

Universal Overhead - Trim Color

Black	BL
Blue Grey	GR
Cool Grey	CG
Light Tone	LG
Misty Brown	MY
Sand	SA
Warm Grey	WG

Starlight Silver is available on aluminum trim pieces only.

Universal overhead door handle trim color automatically coordinates plastic color from the following: Black (BL), Blue Grey (GR), Light Tone (LG), Sand (SA), Warm Grey (WG) trim color coordinate based on paint color.

Venus® Overhead - Cabinet Paint Color

Black	BL
Blue Grey	GR
Bronze Metallic	ZM
Cayenne	CY
Champagne Metallic	CM
Chocolate	CT
Cool Grey	CG
Cottonwood	CO
Espresso Metallic	EX
Flannel	FN
Light Tone	LG
Mardi Gras	MG
Misty Brown	MY
Nemo	NE
Nordic	ND
Purple Haze	PH
Rubber Ducky	RK
Sand	SA
Splash	SH
Starlight Silver Metallic	SX
Surf's Up	SP
Ultra Blue	UB
Warm Grey	WG
Wet Sand	WS
Zesty Lime	ZL

Venus® Overhead - Upper Door Solid Color

Black	UBL
Blue Grey	UGR
Light Tone	ULG
Sand	USA
Translucent	UTR
Warm Grey	UWG
Misty Brown	UMY
Cool Grey	UCG

Venus® Overhead - Shelf Divider Paint Color

Black	BL
Blue Grey	GR
Cool Grey	CG
Light Tone	LG
Misty Brown	MY
Sand	SA
Warm Grey	WG

PowerWorks®

Product Color Options

Accessories-Paper Management - Trim Color

Black	BL
Blue Grey	GR
Clear	CL
Cool Grey	CG
Light Tone	LG
Misty Brown	MY
Sand	SA
Warm Grey	WG

The Clear (CL) color option is only available on Paper Management item PPFH, PPLL, PPDS, PPPVS, PPTC, PPDH, PPAT AND PPPC.

Flat Aluminum Trim - Trim Color

Black	BL
Blue Grey	GR
Bronze Metallic	ZM
Champagne Metallic	CM
Cool Grey	CG
Cottonwood	CO
Espresso Metallic	EX
Light Tone	LG
Misty Brown	MY
Sand	SA
Starlight Silver Metallic	SX
Warm Grey	WG
Wet Sand	WS

120° Worksurfaces/Worksurface Accessories - Trim Color

Black	BL
Blue Grey	GR
Cool Grey	CG
Light Tone	LG
Misty Brown	MY
Sand	SA
Starlight Silver Metallic	SX
Warm Grey	WG

Starlight Silver is available on aluminum trim pieces only.

Fabric Panel - Tackable Acoustic (3/4" Thick Tiles)

Face Styles

Face Style: Fully Segmented

Basic Model: P1FFA - KD1

Basic Model: PFFA-
Pass Through

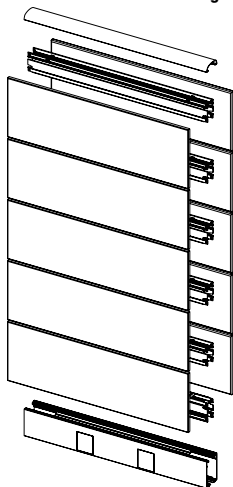

Fully Segmented panels consist of the following: Fabric tiles in 12" increments on both sides.

Quantity of 12" tiles is dependent upon panel height. Base is 6". Panel thickness: 3/2".

*84" high panels include one 18" tile on top.

The 3/4" Tackable/Acoustic tile consists of a 1/2" thick mineral board core with a 1/4" thick fiberglass overlay. Each tile is framed on all four sides with steel. Fabric is glued to the steel frame on the back of the tile.

	STANDARD PANEL SIZES (Fabric-Acoustic)									Side 1	Side 2
	12" W	18" W	24" W	30" W	36" W	42" W	48" W	54" W	60" W	Number of	Number of
30" H	•	•	•	•	•	•	•	•	•	2	2
42" H	•	•	•	•	•	•	•	•	•	3	3
54" H	•	•	•	•	•	•	•	•	•	4	4
66" H	•	•	•	•	•	•	•	•	•	5	5
84" H	•	•	•	•	•	•	•	•	•	5	5*

Face Style: Monolithic/ Half Segmented

Basic Model: P1MHA - KD1

Basic Model: PMHA-
Pass Through

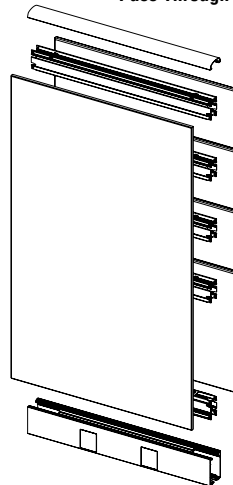

Monolithic/Half Segmented panels consist of the following: Single tile on side one;

a 24" fabric tile on the bottom and 12" segmented tiles on top of side two.

Quantity of 12" segmented tiles is dependent upon panel height. Base is 6". Panel thickness: 3/2".

*84" high panels include one 18" tile on top.

The 3/4" Tackable/Acoustic tile consists of a 1/2" thick mineral board core with a 1/4" thick fiberglass overlay. Each tile is framed on all four sides with steel. Fabric is glued to the steel frame on the back of the tile.

	STANDARD PANEL SIZES (Fabric-Acoustic)									Side 1	Side 2
	12" W	18" W	24" W	30" W	36" W	42" W	48" W	54" W	60" W	Number of	Number of
30" H	N/A	N/A	N/A	N/A	N/A	N/A	N/A	N/A	N/A	N/A	N/A
42" H	•	•	•	•	•	•	•	•	•	N/A	1
54" H	•	•	•	•	•	•	•	•	•	N/A	2
66" H	•	•	•	•	•	•	•	•	•	N/A	3
84" H	•	•	•	•	•	•	•	•	•	N/A	3*

Fabric Panel - Tackable Acoustic (3/4" Thick Tiles)

Face Styles

Face Style: Monolithic/ Fully Segmented

Basic Model: P1MFA - KD1

Basic Model: PMFA-
Pass Through

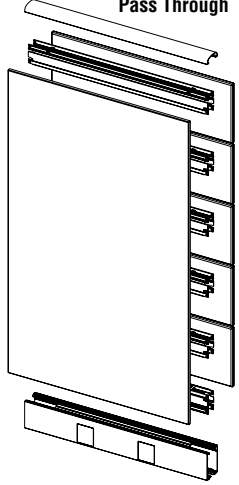

Monolithic/Fully Segmented panels consist of the following: Single tile on side one; 12" segmented tiles on side two. Quantity of 12" segmented tiles is dependent upon panel height. Base is 6". Panel thickness: 3 1/2". *84" high panels include one 18" tile on top.

The 3/4" Tackable/Acoustic tile consists of a 1/2" thick mineral board core with a 1/4" thick fiberglass overlay. Each tile is framed on all four sides with steel. Fabric is glued to the steel frame on the back of the tile.

STANDARD PANEL SIZES (Fabric-Acoustic)

	12" W	18" W	24" W	30" W	36" W	42" W	48" W	54" W	60" W	Side 1 Number of	Side 2 Number of
										12" Fabric Tiles	12" Fabric Tiles
30" H	•	•	•	•	•	•	•	•	•	N/A	2
42" H	•	•	•	•	•	•	•	•	•	N/A	3
54" H	•	•	•	•	•	•	•	•	•	N/A	4
66" H	•	•	•	•	•	•	•	•	•	N/A	5
84" H	•	•	•	•	•	•	•	•	•	N/A	5*

Face Style: Half Segmented/ Fully Segmented

Basic Model: P1HFA - KD1

Basic Model: PHFA-
Pass Through

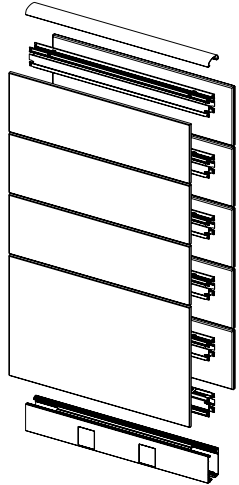

Half Segmented/Fully Segmented panels consist of the following: 24" fabric tile on bottom and 12" segmented tiles on top of side one. 12" segmented fabric tiles on side two. Quantity of 12" segmented tiles is dependent upon panel height. Base is 6". Panel thickness: 3 1/2".

*84" high panels include one 18" tile on top.

The 3/4" Tackable/Acoustic tile consists of a 1/2" thick mineral board core with a 1/4" thick fiberglass overlay. Each tile is framed on all four sides with steel. Fabric is glued to the steel frame on the back of the tile.

STANDARD PANEL SIZES (Fabric-Acoustic)

	12" W	18" W	24" W	30" W	36" W	42" W	48" W	54" W	60" W	Side 1 Number of	Side 2 Number of
										12" Fabric Tiles	12" Fabric Tiles
30" H	N/A	N/A	N/A	N/A	N/A	N/A	N/A	N/A	N/A	N/A	N/A
42" H	•	•	•	•	•	•	•	•	•	1	3
54" H	•	•	•	•	•	•	•	•	•	2	4
66" H	•	•	•	•	•	•	•	•	•	3	5
84" H	•	•	•	•	•	•	•	•	*•	3	5*

Fabric Panel - Tackable Acoustic (3/4" Thick Tiles)

Face Styles



Fabric Panel - Tackable Acoustic (3/4" Thick Tiles)

Monolithic Panel

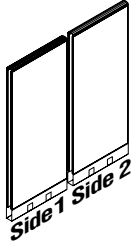
MODEL	W x H	MODEL NUMBER						Approx. Packaged Weight
		Basic Model	Electrical Code	Horizontal Rail	Trim Color	Fabric Side 1	Fabric Side 2	
 <p>Monolithic Panel - 30"H</p> <ul style="list-style-type: none"> • Two horizontal rails • Two fabric tiles with mounting hooks • One base/raceway consisting of a raceway pan and two doors • One rounded satin-textured polypropylene top cap with splice plate • Order power separately • Order vertical posts separately • SX Starlight Silver finish is only offered on flat aluminum trim 	12 x 30"	PMMA1230	<input type="checkbox"/>	<input type="checkbox"/>	<input type="checkbox"/>	<input type="checkbox"/>	<input type="checkbox"/>	14.0#
	18 x 30"	PMMA1830	<input type="checkbox"/>	<input type="checkbox"/>	<input type="checkbox"/>	<input type="checkbox"/>	<input type="checkbox"/>	20.0#
	24 x 30"	PMMA2430	<input type="checkbox"/>	<input type="checkbox"/>	<input type="checkbox"/>	<input type="checkbox"/>	<input type="checkbox"/>	25.0#
	30 x 30"	PMMA3030	<input type="checkbox"/>	<input type="checkbox"/>	<input type="checkbox"/>	<input type="checkbox"/>	<input type="checkbox"/>	30.0#
	36 x 30"	PMMA3630	<input type="checkbox"/>	<input type="checkbox"/>	<input type="checkbox"/>	<input type="checkbox"/>	<input type="checkbox"/>	36.0#
	42 x 30"	PMMA4230	<input type="checkbox"/>	<input type="checkbox"/>	<input type="checkbox"/>	<input type="checkbox"/>	<input type="checkbox"/>	41.0#
	48 x 30"	PMMA4830	<input type="checkbox"/>	<input type="checkbox"/>	<input type="checkbox"/>	<input type="checkbox"/>	<input type="checkbox"/>	46.0#
	54 x 30"	PMMA5430	<input type="checkbox"/>	<input type="checkbox"/>	<input type="checkbox"/>	<input type="checkbox"/>	<input type="checkbox"/>	52.0#
	60 x 30"	PMMA6030	<input type="checkbox"/>	<input type="checkbox"/>	<input type="checkbox"/>	<input type="checkbox"/>	<input type="checkbox"/>	58.0#
	P1MMA - KD1 PMMA - Pass Through							
<p>Monolithic Panel - 42"H</p> <p>P1MMA - KD1 PMMA - Pass Through</p>	12 x 42"	PMMA1242	<input type="checkbox"/>	<input type="checkbox"/>	<input type="checkbox"/>	<input type="checkbox"/>	<input type="checkbox"/>	18.0#
	18 x 42"	PMMA1842	<input type="checkbox"/>	<input type="checkbox"/>	<input type="checkbox"/>	<input type="checkbox"/>	<input type="checkbox"/>	24.0#
	24 x 42"	PMMA2442	<input type="checkbox"/>	<input type="checkbox"/>	<input type="checkbox"/>	<input type="checkbox"/>	<input type="checkbox"/>	30.0#
	30 x 42"	PMMA3042	<input type="checkbox"/>	<input type="checkbox"/>	<input type="checkbox"/>	<input type="checkbox"/>	<input type="checkbox"/>	36.0#
	36 x 42"	PMMA3642	<input type="checkbox"/>	<input type="checkbox"/>	<input type="checkbox"/>	<input type="checkbox"/>	<input type="checkbox"/>	42.0#
	42 x 42"	PMMA4242	<input type="checkbox"/>	<input type="checkbox"/>	<input type="checkbox"/>	<input type="checkbox"/>	<input type="checkbox"/>	51.0#
	48 x 42"	PMMA4842	<input type="checkbox"/>	<input type="checkbox"/>	<input type="checkbox"/>	<input type="checkbox"/>	<input type="checkbox"/>	53.0#
	54 x 42"	PMMA5442	<input type="checkbox"/>	<input type="checkbox"/>	<input type="checkbox"/>	<input type="checkbox"/>	<input type="checkbox"/>	60.0#
60 x 42"	PMMA6042	<input type="checkbox"/>	<input type="checkbox"/>	<input type="checkbox"/>	<input type="checkbox"/>	<input type="checkbox"/>	67.0#	
<p>Monolithic Panel - 54"H</p> <p>P1MMA - KD1 PMMA - Pass Through</p>	12 x 54"	PMMA1254	<input type="checkbox"/>	<input type="checkbox"/>	<input type="checkbox"/>	<input type="checkbox"/>	<input type="checkbox"/>	21.0#
	18 x 54"	PMMA1854	<input type="checkbox"/>	<input type="checkbox"/>	<input type="checkbox"/>	<input type="checkbox"/>	<input type="checkbox"/>	30.0#
	24 x 54"	PMMA2454	<input type="checkbox"/>	<input type="checkbox"/>	<input type="checkbox"/>	<input type="checkbox"/>	<input type="checkbox"/>	35.0#
	30 x 54"	PMMA3054	<input type="checkbox"/>	<input type="checkbox"/>	<input type="checkbox"/>	<input type="checkbox"/>	<input type="checkbox"/>	41.0#
	36 x 54"	PMMA3654	<input type="checkbox"/>	<input type="checkbox"/>	<input type="checkbox"/>	<input type="checkbox"/>	<input type="checkbox"/>	48.0#
	42 x 54"	PMMA4254	<input type="checkbox"/>	<input type="checkbox"/>	<input type="checkbox"/>	<input type="checkbox"/>	<input type="checkbox"/>	54.0#
	48 x 54"	PMMA4854	<input type="checkbox"/>	<input type="checkbox"/>	<input type="checkbox"/>	<input type="checkbox"/>	<input type="checkbox"/>	61.0#
	54 x 54"	PMMA5454	<input type="checkbox"/>	<input type="checkbox"/>	<input type="checkbox"/>	<input type="checkbox"/>	<input type="checkbox"/>	68.0#
	60 x 54"	PMMA6054	<input type="checkbox"/>	<input type="checkbox"/>	<input type="checkbox"/>	<input type="checkbox"/>	<input type="checkbox"/>	75.0#

A **B** **C** **D** **E** **F**

HOW TO ORDER

Indicate the following information on order form:

1. Quantity of each item.
2. Model number, including options. See "How To Build a Model Number".
3. Any special service required.

Note: • The indicates that a choice is required.

- The absence of the indicates that no choice is required.
- Alpha-numeric characters in place of indicate that no other alternatives are available.

HOW TO BUILD A MODEL NUMBER

- A** Select basic model.
- B** Select electrical code for base raceway.

DN	- Domestic, no cutouts
D1	- Domestic, 1 side w/cutouts
D	- Domestic, 2 sides w/cutouts
- C** Select horizontal rail.

E	- Enhanced
S	- Standard
- D** Select trim color. Refer to the **Product Color Options** page in this catalog. SX Starlight Silver finish is only offered on flat aluminum trim.
- E** Select fabric side 1.
- F** Select fabric side 2.

Fabric Panel - Tackable Acoustic (3/4" Thick Tiles)

Monolithic Panel

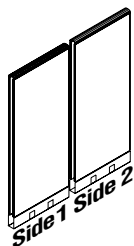

P1MMA - KD1
PMMA - Pass Through

MODEL	W x H	MODEL NUMBER						Approx. Packaged Weight
		Basic Model	Electrical Code	Horizontal Rail	Trim Color	Fabric Side 1	Fabric Side 2	
Monolithic Panel - 66"H • Two horizontal rails • Two fabric tiles with mounting hooks • One base/raceway consisting of a raceway pan and two doors • One rounded satin-textured polypropylene top cap with splice plate • Order power separately • Order vertical posts separately • SX Starlight Silver finish is only offered on flat aluminum trim	12 x 66"	PMMA1266	<input type="checkbox"/>	<input type="checkbox"/>	<input type="checkbox"/>	<input type="checkbox"/>	<input type="checkbox"/>	25.0#
	18 x 66"	PMMA1866	<input type="checkbox"/>	<input type="checkbox"/>	<input type="checkbox"/>	<input type="checkbox"/>	<input type="checkbox"/>	32.0#
	24 x 66"	PMMA2466	<input type="checkbox"/>	<input type="checkbox"/>	<input type="checkbox"/>	<input type="checkbox"/>	<input type="checkbox"/>	39.0#
	30 x 66"	PMMA3066	<input type="checkbox"/>	<input type="checkbox"/>	<input type="checkbox"/>	<input type="checkbox"/>	<input type="checkbox"/>	47.0#
	36 x 66"	PMMA3666	<input type="checkbox"/>	<input type="checkbox"/>	<input type="checkbox"/>	<input type="checkbox"/>	<input type="checkbox"/>	54.0#
	42 x 66"	PMMA4266	<input type="checkbox"/>	<input type="checkbox"/>	<input type="checkbox"/>	<input type="checkbox"/>	<input type="checkbox"/>	61.0#
	48 x 66"	PMMA4866	<input type="checkbox"/>	<input type="checkbox"/>	<input type="checkbox"/>	<input type="checkbox"/>	<input type="checkbox"/>	68.0#
	54 x 66"	PMMA5466	<input type="checkbox"/>	<input type="checkbox"/>	<input type="checkbox"/>	<input type="checkbox"/>	<input type="checkbox"/>	75.0#
	60 x 66"	PMMA6066	<input type="checkbox"/>	<input type="checkbox"/>	<input type="checkbox"/>	<input type="checkbox"/>	<input type="checkbox"/>	84.0#
Monolithic Panel - 84"H	12 x 84"	PMMA1284	<input type="checkbox"/>	<input type="checkbox"/>	<input type="checkbox"/>	<input type="checkbox"/>	<input type="checkbox"/>	30.0#
	18 x 84"	PMMA1884	<input type="checkbox"/>	<input type="checkbox"/>	<input type="checkbox"/>	<input type="checkbox"/>	<input type="checkbox"/>	38.0#
	24 x 84"	PMMA2484	<input type="checkbox"/>	<input type="checkbox"/>	<input type="checkbox"/>	<input type="checkbox"/>	<input type="checkbox"/>	47.0#
	30 x 84"	PMMA3084	<input type="checkbox"/>	<input type="checkbox"/>	<input type="checkbox"/>	<input type="checkbox"/>	<input type="checkbox"/>	55.0#
	36 x 84"	PMMA3684	<input type="checkbox"/>	<input type="checkbox"/>	<input type="checkbox"/>	<input type="checkbox"/>	<input type="checkbox"/>	63.0#
	42 x 84"	PMMA4284	<input type="checkbox"/>	<input type="checkbox"/>	<input type="checkbox"/>	<input type="checkbox"/>	<input type="checkbox"/>	71.0#
	48 x 84"	PMMA4884	<input type="checkbox"/>	<input type="checkbox"/>	<input type="checkbox"/>	<input type="checkbox"/>	<input type="checkbox"/>	79.0#
	54 x 84"	PMMA5484	<input type="checkbox"/>	<input type="checkbox"/>	<input type="checkbox"/>	<input type="checkbox"/>	<input type="checkbox"/>	87.0#
60 x 84"	PMMA6084	<input type="checkbox"/>	<input type="checkbox"/>	<input type="checkbox"/>	<input type="checkbox"/>	<input type="checkbox"/>	97.0#	

A **B** **C** **D** **E** **F**

HOW TO ORDER

Indicate the following information on order form:

- Quantity of each item.
- Model number, including options. See "How To Build a Model Number".
- Any special service required.

Note: • The indicates that a choice is required.
 • The absence of the indicates that no choice is required.
 • Alpha-numeric characters in place of indicate that no other alternatives are available.

HOW TO BUILD A MODEL NUMBER

- A** Select basic model.
- B** Select electrical code for base raceway.

DN	- Domestic, no cutouts
D1	- Domestic, 1 side w/cutouts
D	- Domestic, 2 sides w/cutouts
- C** Select horizontal rail.

E	- Enhanced
S	- Standard
- D** Select trim color.
 Refer to the **Product Color Options** page in this catalog.
 SX Starlight Silver finish is only offered on flat aluminum trim.
- E** Select fabric side 1.
- F** Select fabric side 2.

Fabric Panel - Tackable Acoustic (3/4" Thick Tiles)

Monolithic/Half Segmented Panel

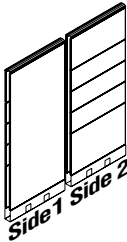
MODEL	W x H	MODEL NUMBER								Approx. Packaged Weight	
		Basic Model	Electrical Code	Horizontal Rail	Number of Raceway Tiles Side 1	Number of Raceway Tiles Side 2	Trim Color	Fabric Side 1	Fabric Side 2		
 <p>P1MHA - KD1 PMHA - Pass Through</p>	Monolithic/Half Segmented Panel - 42"H with 12"H tiles	12 x 42"	PMHA1242	<input type="checkbox"/>	<input type="checkbox"/>	R0	<input type="checkbox"/>	<input type="checkbox"/>	<input type="checkbox"/>	<input type="checkbox"/>	21.0#
	18 x 42"	PMHA1842	<input type="checkbox"/>	<input type="checkbox"/>	R0	<input type="checkbox"/>	<input type="checkbox"/>	<input type="checkbox"/>	<input type="checkbox"/>	<input type="checkbox"/>	29.0#
	• Three to six horizontal rails	24 x 42"	PMHA2442	<input type="checkbox"/>	<input type="checkbox"/>	R0	<input type="checkbox"/>	<input type="checkbox"/>	<input type="checkbox"/>	<input type="checkbox"/>	36.0#
	• One, two or three 12" fabric tiles with mounting hooks	30 x 42"	PMHA3042	<input type="checkbox"/>	<input type="checkbox"/>	R0	<input type="checkbox"/>	<input type="checkbox"/>	<input type="checkbox"/>	<input type="checkbox"/>	44.0#
	• One 18" fabric tile included with 84" high panels with mounting hooks	36 x 42"	PMHA3642	<input type="checkbox"/>	<input type="checkbox"/>	R0	<input type="checkbox"/>	<input type="checkbox"/>	<input type="checkbox"/>	<input type="checkbox"/>	51.0#
	• One base/raceway consisting of a raceway pan and two doors	42 x 42"	PMHA4242	<input type="checkbox"/>	<input type="checkbox"/>	R0	<input type="checkbox"/>	<input type="checkbox"/>	<input type="checkbox"/>	<input type="checkbox"/>	56.0#
	• One rounded satin-textured polypropylene top cap with splice plate	48 x 42"	PMHA4842	<input type="checkbox"/>	<input type="checkbox"/>	R0	<input type="checkbox"/>	<input type="checkbox"/>	<input type="checkbox"/>	<input type="checkbox"/>	66.0#
	• One rounded satin-textured polypropylene top cap with splice plate	54 x 42"	PMHA5442	<input type="checkbox"/>	<input type="checkbox"/>	R0	<input type="checkbox"/>	<input type="checkbox"/>	<input type="checkbox"/>	<input type="checkbox"/>	74.0#
• Order power separately	60 x 42"	PMHA6042	<input type="checkbox"/>	<input type="checkbox"/>	R0	<input type="checkbox"/>	<input type="checkbox"/>	<input type="checkbox"/>	<input type="checkbox"/>	83.0#	
• Order vertical posts separately											
• SX Starlight Silver finish is only offered on flat aluminum trim											
<p>P1MHA - KD1 PMHA - Pass Through</p>	Monolithic/Half Segmented Panel - 54"H with 12"H tiles	12 x 54"	PMHA1254	<input type="checkbox"/>	<input type="checkbox"/>	R0	<input type="checkbox"/>	<input type="checkbox"/>	<input type="checkbox"/>	<input type="checkbox"/>	27.0#
	18 x 54"	PMHA1854	<input type="checkbox"/>	<input type="checkbox"/>	R0	<input type="checkbox"/>	<input type="checkbox"/>	<input type="checkbox"/>	<input type="checkbox"/>	<input type="checkbox"/>	37.0#
	24 x 54"	PMHA2454	<input type="checkbox"/>	<input type="checkbox"/>	R0	<input type="checkbox"/>	<input type="checkbox"/>	<input type="checkbox"/>	<input type="checkbox"/>	<input type="checkbox"/>	48.0#
	30 x 54"	PMHA3054	<input type="checkbox"/>	<input type="checkbox"/>	R0	<input type="checkbox"/>	<input type="checkbox"/>	<input type="checkbox"/>	<input type="checkbox"/>	<input type="checkbox"/>	57.0#
	36 x 54"	PMHA3654	<input type="checkbox"/>	<input type="checkbox"/>	R0	<input type="checkbox"/>	<input type="checkbox"/>	<input type="checkbox"/>	<input type="checkbox"/>	<input type="checkbox"/>	67.0#
	42 x 54"	PMHA4254	<input type="checkbox"/>	<input type="checkbox"/>	R0	<input type="checkbox"/>	<input type="checkbox"/>	<input type="checkbox"/>	<input type="checkbox"/>	<input type="checkbox"/>	77.0#
	48 x 54"	PMHA4854	<input type="checkbox"/>	<input type="checkbox"/>	R0	<input type="checkbox"/>	<input type="checkbox"/>	<input type="checkbox"/>	<input type="checkbox"/>	<input type="checkbox"/>	86.0#
	54 x 54"	PMHA5454	<input type="checkbox"/>	<input type="checkbox"/>	R0	<input type="checkbox"/>	<input type="checkbox"/>	<input type="checkbox"/>	<input type="checkbox"/>	<input type="checkbox"/>	97.0#
60 x 54"	PMHA6054	<input type="checkbox"/>	<input type="checkbox"/>	R0	<input type="checkbox"/>	<input type="checkbox"/>	<input type="checkbox"/>	<input type="checkbox"/>	<input type="checkbox"/>	108.0#	

A B C D E F G H

HOW TO ORDER

Indicate the following information on order form:

- Quantity of each item.
- Model number, including options. See "How To Build a Model Number".
- Any special service required.

Note: • The indicates that a choice is required.
• The absence of the indicates that no choice is required.
• Alpha-numeric characters in place of indicate that no other alternatives are available.

HOW TO BUILD A MODEL NUMBER

- A** Select basic model.
- B** Select electrical code for base raceway.
 - DN** - Domestic, no cutouts
 - D1** - Domestic, 1 side w/cutouts
 - D** - Domestic, 2 sides w/cutouts
- C** Select horizontal rail.
 - E** - Enhanced
 - S** - Standard
- D** Select numbers of raceway tiles side 1
 - R0** - Side 1 w/no raceway tile
- E** Select numbers of raceway tiles side 2
 - R20** - Side 2 w/no raceway tile
 - R21** - Side 2 w/1-12" raceway tile
 - R22** - Side 2 w/2-12" raceway tiles
- F** Select trim color. Refer to the **Product Color Options** page in this catalog. SX Starlight Silver finish is only offered on flat aluminum trim.
- G** Select fabric side 1.
- H** Select fabric side 2.

INFORMATION

Maximum Raceway Tile Possibilities

Panel Height	Side 1	Side 2
42"H	0	1
54"H	0	2
66"H	0	2
84"H	0	2

Fabric Panel - Tackable Acoustic (3/4" Thick Tiles)

Monolithic/Half Segmented Panel

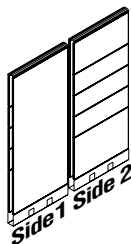

P1MHA - KD1
PMHA - Pass Through

MODEL

Monolithic/Half Segmented Panel - 66"H with 12"H tiles

- Three to six horizontal rails
- One, two or three 12" fabric tiles with mounting hooks
- One 18" fabric tile included with 84" high panels with mounting hooks
- One base/raceway consisting of a raceway pan and two doors
- One rounded satin-textured polypropylene top cap with splice plate
- Order power separately
- Order vertical posts separately
- SX Starlight Silver finish is only offered on flat aluminum trim

MODEL	W x H	MODEL NUMBER								Approx. Packaged Weight
		Basic Model	Electrical Code	Horizontal Rail	Number of Raceway Tiles Side 1	Number of Raceway Tiles Side 2	Trim Color	Fabric Side 1	Fabric Side 2	
P1MHA - KD1 PMHA - Pass Through	12 x 66"	PMHA1266	<input type="checkbox"/>	<input type="checkbox"/>	R0	<input type="checkbox"/>	<input type="checkbox"/>	<input type="checkbox"/>	<input type="checkbox"/>	34.0#
	18 x 66"	PMHA1866	<input type="checkbox"/>	<input type="checkbox"/>	R0	<input type="checkbox"/>	<input type="checkbox"/>	<input type="checkbox"/>	<input type="checkbox"/>	46.0#
	24 x 66"	PMHA2466	<input type="checkbox"/>	<input type="checkbox"/>	R0	<input type="checkbox"/>	<input type="checkbox"/>	<input type="checkbox"/>	<input type="checkbox"/>	59.0#
	30 x 66"	PMHA3066	<input type="checkbox"/>	<input type="checkbox"/>	R0	<input type="checkbox"/>	<input type="checkbox"/>	<input type="checkbox"/>	<input type="checkbox"/>	71.0#
	36 x 66"	PMHA3666	<input type="checkbox"/>	<input type="checkbox"/>	R0	<input type="checkbox"/>	<input type="checkbox"/>	<input type="checkbox"/>	<input type="checkbox"/>	83.0#
	42 x 66"	PMHA4266	<input type="checkbox"/>	<input type="checkbox"/>	R0	<input type="checkbox"/>	<input type="checkbox"/>	<input type="checkbox"/>	<input type="checkbox"/>	95.0#
	48 x 66"	PMHA4866	<input type="checkbox"/>	<input type="checkbox"/>	R0	<input type="checkbox"/>	<input type="checkbox"/>	<input type="checkbox"/>	<input type="checkbox"/>	106.0#
	54 x 66"	PMHA5466	<input type="checkbox"/>	<input type="checkbox"/>	R0	<input type="checkbox"/>	<input type="checkbox"/>	<input type="checkbox"/>	<input type="checkbox"/>	119.0#
60 x 66"	PMHA6066	<input type="checkbox"/>	<input type="checkbox"/>	R0	<input type="checkbox"/>	<input type="checkbox"/>	<input type="checkbox"/>	<input type="checkbox"/>	133.0#	
P1MHA - KD1 PMHA - Pass Through	12 x 84"	PMHA1284	<input type="checkbox"/>	<input type="checkbox"/>	R0	<input type="checkbox"/>	<input type="checkbox"/>	<input type="checkbox"/>	<input type="checkbox"/>	42.0#
	18 x 84"	PMHA1884	<input type="checkbox"/>	<input type="checkbox"/>	R0	<input type="checkbox"/>	<input type="checkbox"/>	<input type="checkbox"/>	<input type="checkbox"/>	57.0#
	24 x 84"	PMHA2484	<input type="checkbox"/>	<input type="checkbox"/>	R0	<input type="checkbox"/>	<input type="checkbox"/>	<input type="checkbox"/>	<input type="checkbox"/>	72.0#
	30 x 84"	PMHA3084	<input type="checkbox"/>	<input type="checkbox"/>	R0	<input type="checkbox"/>	<input type="checkbox"/>	<input type="checkbox"/>	<input type="checkbox"/>	87.0#
	36 x 84"	PMHA3684	<input type="checkbox"/>	<input type="checkbox"/>	R0	<input type="checkbox"/>	<input type="checkbox"/>	<input type="checkbox"/>	<input type="checkbox"/>	101.0#
	42 x 84"	PMHA4284	<input type="checkbox"/>	<input type="checkbox"/>	R0	<input type="checkbox"/>	<input type="checkbox"/>	<input type="checkbox"/>	<input type="checkbox"/>	116.0#
	48 x 84"	PMHA4884	<input type="checkbox"/>	<input type="checkbox"/>	R0	<input type="checkbox"/>	<input type="checkbox"/>	<input type="checkbox"/>	<input type="checkbox"/>	130.0#
	54 x 84"	PMHA5484	<input type="checkbox"/>	<input type="checkbox"/>	R0	<input type="checkbox"/>	<input type="checkbox"/>	<input type="checkbox"/>	<input type="checkbox"/>	145.0#
60 x 84"	PMHA6084	<input type="checkbox"/>	<input type="checkbox"/>	R0	<input type="checkbox"/>	<input type="checkbox"/>	<input type="checkbox"/>	<input type="checkbox"/>	163.0#	

A B C D E F G H

HOW TO ORDER

Indicate the following information on order form:

1. Quantity of each item.
2. Model number, including options. See "How To Build a Model Number".
3. Any special service required.

Note: • The indicates that a choice is required.
• The absence of the indicates that no choice is required.
• Alpha-numeric characters in place of indicate that no other alternatives are available.

HOW TO BUILD A MODEL NUMBER

- A** Select basic model.
- B** Select electrical code for base raceway.
 - DN - Domestic, no cutouts
 - D1 - Domestic, 1 side w/cutouts
 - D - Domestic, 2 sides w/cutouts
- C** Select horizontal rail.
 - E - Enhanced
 - S - Standard
- D** Select numbers of raceway tiles side 1
 - R0 - Side 1 w/no raceway tile
- E** Select numbers of raceway tiles side 2
 - R20 - Side 2 w/no raceway tile
 - R21 - Side 2 w/1-12" raceway tile
 - R22 - Side 2 w/2-12" raceway tiles
- F** Select trim color. Refer to the **Product Color Options** page in this catalog. SX Starlight Silver finish is only offered on flat aluminum trim.
- G** Select fabric side 1.
- H** Select fabric side 2.

INFORMATION

Maximum Raceway Tile Possibilities

Panel Height	Side 1	Side 2
42"H	0	1
54"H	0	2
66"H	0	2
84"H	0	2

Fabric Panel - Tackable Acoustic (3/4" Thick Tiles)

Monolithic/Fully Segmented Panel

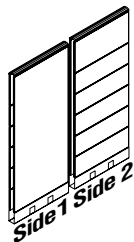

P1MFA - KD1
PMFA - Pass Through

MODEL	W x H	MODEL NUMBER								Approx. Packaged Weight
		Basic Model	Electrical Code	Horizontal Rail	Number of Raceway Tiles Side 1	Number of Raceway Tiles Side 2	Trim Color	Fabric Side 1	Fabric Side 2	
Monolithic/Fully Segmented Panel - 54"H with 12"H tiles • Three to six horizontal rails • Two, three, four or five 12" fabric tiles with mounting hooks • One 18" fabric tile included with 84" high panels with mounting hooks • One base/raceway consisting of a raceway pan and two doors • One rounded satin-textured polypropylene top cap with splice plate • Order power separately • Order vertical posts separately • SX Starlight Silver finish is only offered on flat aluminum trim	12 x 54"	PMFA1254	<input type="checkbox"/> <input type="checkbox"/>	<input type="checkbox"/>	R0	<input type="checkbox"/> <input type="checkbox"/> <input type="checkbox"/>	<input type="checkbox"/>	<input type="checkbox"/> <input type="checkbox"/> <input type="checkbox"/> <input type="checkbox"/>	<input type="checkbox"/> <input type="checkbox"/> <input type="checkbox"/> <input type="checkbox"/>	54.0#
	18 x 54"	PMFA1854	<input type="checkbox"/> <input type="checkbox"/>	<input type="checkbox"/>	R0	<input type="checkbox"/> <input type="checkbox"/> <input type="checkbox"/>	<input type="checkbox"/>	<input type="checkbox"/> <input type="checkbox"/> <input type="checkbox"/> <input type="checkbox"/>	<input type="checkbox"/> <input type="checkbox"/> <input type="checkbox"/> <input type="checkbox"/>	70.0#
	24 x 54"	PMFA2454	<input type="checkbox"/> <input type="checkbox"/>	<input type="checkbox"/>	R0	<input type="checkbox"/> <input type="checkbox"/> <input type="checkbox"/>	<input type="checkbox"/>	<input type="checkbox"/> <input type="checkbox"/> <input type="checkbox"/> <input type="checkbox"/>	<input type="checkbox"/> <input type="checkbox"/> <input type="checkbox"/> <input type="checkbox"/>	87.0#
	30 x 54"	PMFA3054	<input type="checkbox"/> <input type="checkbox"/>	<input type="checkbox"/>	R0	<input type="checkbox"/> <input type="checkbox"/> <input type="checkbox"/>	<input type="checkbox"/>	<input type="checkbox"/> <input type="checkbox"/> <input type="checkbox"/> <input type="checkbox"/>	<input type="checkbox"/> <input type="checkbox"/> <input type="checkbox"/> <input type="checkbox"/>	103.0#
	36 x 54"	PMFA3654	<input type="checkbox"/> <input type="checkbox"/>	<input type="checkbox"/>	R0	<input type="checkbox"/> <input type="checkbox"/> <input type="checkbox"/>	<input type="checkbox"/>	<input type="checkbox"/> <input type="checkbox"/> <input type="checkbox"/> <input type="checkbox"/>	<input type="checkbox"/> <input type="checkbox"/> <input type="checkbox"/> <input type="checkbox"/>	119.0#
	42 x 54"	PMFA4254	<input type="checkbox"/> <input type="checkbox"/>	<input type="checkbox"/>	R0	<input type="checkbox"/> <input type="checkbox"/> <input type="checkbox"/>	<input type="checkbox"/>	<input type="checkbox"/> <input type="checkbox"/> <input type="checkbox"/> <input type="checkbox"/>	<input type="checkbox"/> <input type="checkbox"/> <input type="checkbox"/> <input type="checkbox"/>	135.0#
	48 x 54"	PMFA4854	<input type="checkbox"/> <input type="checkbox"/>	<input type="checkbox"/>	R0	<input type="checkbox"/> <input type="checkbox"/> <input type="checkbox"/>	<input type="checkbox"/>	<input type="checkbox"/> <input type="checkbox"/> <input type="checkbox"/> <input type="checkbox"/>	<input type="checkbox"/> <input type="checkbox"/> <input type="checkbox"/> <input type="checkbox"/>	150.0#
	54 x 54"	PMFA5454	<input type="checkbox"/> <input type="checkbox"/>	<input type="checkbox"/>	R0	<input type="checkbox"/> <input type="checkbox"/> <input type="checkbox"/>	<input type="checkbox"/>	<input type="checkbox"/> <input type="checkbox"/> <input type="checkbox"/> <input type="checkbox"/>	<input type="checkbox"/> <input type="checkbox"/> <input type="checkbox"/> <input type="checkbox"/>	166.0#
	60 x 54"	PMFA6054	<input type="checkbox"/> <input type="checkbox"/>	<input type="checkbox"/>	R0	<input type="checkbox"/> <input type="checkbox"/> <input type="checkbox"/>	<input type="checkbox"/>	<input type="checkbox"/> <input type="checkbox"/> <input type="checkbox"/> <input type="checkbox"/>	<input type="checkbox"/> <input type="checkbox"/> <input type="checkbox"/> <input type="checkbox"/>	176.0#
	Monolithic/Fully Segmented Panel - 66"H with 12"H tiles	12 x 66"	PMFA1266	<input type="checkbox"/> <input type="checkbox"/>	<input type="checkbox"/>	R0	<input type="checkbox"/> <input type="checkbox"/> <input type="checkbox"/>	<input type="checkbox"/>	<input type="checkbox"/> <input type="checkbox"/> <input type="checkbox"/> <input type="checkbox"/>	<input type="checkbox"/> <input type="checkbox"/> <input type="checkbox"/> <input type="checkbox"/>
18 x 66"		PMFA1866	<input type="checkbox"/> <input type="checkbox"/>	<input type="checkbox"/>	R0	<input type="checkbox"/> <input type="checkbox"/> <input type="checkbox"/>	<input type="checkbox"/>	<input type="checkbox"/> <input type="checkbox"/> <input type="checkbox"/> <input type="checkbox"/>	<input type="checkbox"/> <input type="checkbox"/> <input type="checkbox"/> <input type="checkbox"/>	51.0#
24 x 66"		PMFA2466	<input type="checkbox"/> <input type="checkbox"/>	<input type="checkbox"/>	R0	<input type="checkbox"/> <input type="checkbox"/> <input type="checkbox"/>	<input type="checkbox"/>	<input type="checkbox"/> <input type="checkbox"/> <input type="checkbox"/> <input type="checkbox"/>	<input type="checkbox"/> <input type="checkbox"/> <input type="checkbox"/> <input type="checkbox"/>	65.0#
30 x 66"		PMFA3066	<input type="checkbox"/> <input type="checkbox"/>	<input type="checkbox"/>	R0	<input type="checkbox"/> <input type="checkbox"/> <input type="checkbox"/>	<input type="checkbox"/>	<input type="checkbox"/> <input type="checkbox"/> <input type="checkbox"/> <input type="checkbox"/>	<input type="checkbox"/> <input type="checkbox"/> <input type="checkbox"/> <input type="checkbox"/>	79.0#
36 x 66"		PMFA3666	<input type="checkbox"/> <input type="checkbox"/>	<input type="checkbox"/>	R0	<input type="checkbox"/> <input type="checkbox"/> <input type="checkbox"/>	<input type="checkbox"/>	<input type="checkbox"/> <input type="checkbox"/> <input type="checkbox"/> <input type="checkbox"/>	<input type="checkbox"/> <input type="checkbox"/> <input type="checkbox"/> <input type="checkbox"/>	92.0#
42 x 66"		PMFA4266	<input type="checkbox"/> <input type="checkbox"/>	<input type="checkbox"/>	R0	<input type="checkbox"/> <input type="checkbox"/> <input type="checkbox"/>	<input type="checkbox"/>	<input type="checkbox"/> <input type="checkbox"/> <input type="checkbox"/> <input type="checkbox"/>	<input type="checkbox"/> <input type="checkbox"/> <input type="checkbox"/> <input type="checkbox"/>	106.0#
48 x 66"		PMFA4866	<input type="checkbox"/> <input type="checkbox"/>	<input type="checkbox"/>	R0	<input type="checkbox"/> <input type="checkbox"/> <input type="checkbox"/>	<input type="checkbox"/>	<input type="checkbox"/> <input type="checkbox"/> <input type="checkbox"/> <input type="checkbox"/>	<input type="checkbox"/> <input type="checkbox"/> <input type="checkbox"/> <input type="checkbox"/>	120.0#
54 x 66"		PMFA5466	<input type="checkbox"/> <input type="checkbox"/>	<input type="checkbox"/>	R0	<input type="checkbox"/> <input type="checkbox"/> <input type="checkbox"/>	<input type="checkbox"/>	<input type="checkbox"/> <input type="checkbox"/> <input type="checkbox"/> <input type="checkbox"/>	<input type="checkbox"/> <input type="checkbox"/> <input type="checkbox"/> <input type="checkbox"/>	133.0#
60 x 66"	PMFA6066	<input type="checkbox"/> <input type="checkbox"/>	<input type="checkbox"/>	R0	<input type="checkbox"/> <input type="checkbox"/> <input type="checkbox"/>	<input type="checkbox"/>	<input type="checkbox"/> <input type="checkbox"/> <input type="checkbox"/> <input type="checkbox"/>	<input type="checkbox"/> <input type="checkbox"/> <input type="checkbox"/> <input type="checkbox"/>	150.0#	
Monolithic/Fully Segmented Panel - 84"H with 12"H tiles	12 x 84"	PMFA1284	<input type="checkbox"/> <input type="checkbox"/>	<input type="checkbox"/>	R0	<input type="checkbox"/> <input type="checkbox"/> <input type="checkbox"/>	<input type="checkbox"/>	<input type="checkbox"/> <input type="checkbox"/> <input type="checkbox"/> <input type="checkbox"/>	<input type="checkbox"/> <input type="checkbox"/> <input type="checkbox"/> <input type="checkbox"/>	45.0#
	18 x 84"	PMFA1884	<input type="checkbox"/> <input type="checkbox"/>	<input type="checkbox"/>	R0	<input type="checkbox"/> <input type="checkbox"/> <input type="checkbox"/>	<input type="checkbox"/>	<input type="checkbox"/> <input type="checkbox"/> <input type="checkbox"/> <input type="checkbox"/>	<input type="checkbox"/> <input type="checkbox"/> <input type="checkbox"/> <input type="checkbox"/>	62.0#
	24 x 84"	PMFA2484	<input type="checkbox"/> <input type="checkbox"/>	<input type="checkbox"/>	R0	<input type="checkbox"/> <input type="checkbox"/> <input type="checkbox"/>	<input type="checkbox"/>	<input type="checkbox"/> <input type="checkbox"/> <input type="checkbox"/> <input type="checkbox"/>	<input type="checkbox"/> <input type="checkbox"/> <input type="checkbox"/> <input type="checkbox"/>	79.0#
	30 x 84"	PMFA3084	<input type="checkbox"/> <input type="checkbox"/>	<input type="checkbox"/>	R0	<input type="checkbox"/> <input type="checkbox"/> <input type="checkbox"/>	<input type="checkbox"/>	<input type="checkbox"/> <input type="checkbox"/> <input type="checkbox"/> <input type="checkbox"/>	<input type="checkbox"/> <input type="checkbox"/> <input type="checkbox"/> <input type="checkbox"/>	95.0#
	36 x 84"	PMFA3684	<input type="checkbox"/> <input type="checkbox"/>	<input type="checkbox"/>	R0	<input type="checkbox"/> <input type="checkbox"/> <input type="checkbox"/>	<input type="checkbox"/>	<input type="checkbox"/> <input type="checkbox"/> <input type="checkbox"/> <input type="checkbox"/>	<input type="checkbox"/> <input type="checkbox"/> <input type="checkbox"/> <input type="checkbox"/>	112.0#
	42 x 84"	PMFA4284	<input type="checkbox"/> <input type="checkbox"/>	<input type="checkbox"/>	R0	<input type="checkbox"/> <input type="checkbox"/> <input type="checkbox"/>	<input type="checkbox"/>	<input type="checkbox"/> <input type="checkbox"/> <input type="checkbox"/> <input type="checkbox"/>	<input type="checkbox"/> <input type="checkbox"/> <input type="checkbox"/> <input type="checkbox"/>	127.0#
	48 x 84"	PMFA4884	<input type="checkbox"/> <input type="checkbox"/>	<input type="checkbox"/>	R0	<input type="checkbox"/> <input type="checkbox"/> <input type="checkbox"/>	<input type="checkbox"/>	<input type="checkbox"/> <input type="checkbox"/> <input type="checkbox"/> <input type="checkbox"/>	<input type="checkbox"/> <input type="checkbox"/> <input type="checkbox"/> <input type="checkbox"/>	143.0#
	54 x 84"	PMFA5484	<input type="checkbox"/> <input type="checkbox"/>	<input type="checkbox"/>	R0	<input type="checkbox"/> <input type="checkbox"/> <input type="checkbox"/>	<input type="checkbox"/>	<input type="checkbox"/> <input type="checkbox"/> <input type="checkbox"/> <input type="checkbox"/>	<input type="checkbox"/> <input type="checkbox"/> <input type="checkbox"/> <input type="checkbox"/>	160.0#
60 x 84"	PMFA6084	<input type="checkbox"/> <input type="checkbox"/>	<input type="checkbox"/>	R0	<input type="checkbox"/> <input type="checkbox"/> <input type="checkbox"/>	<input type="checkbox"/>	<input type="checkbox"/> <input type="checkbox"/> <input type="checkbox"/> <input type="checkbox"/>	<input type="checkbox"/> <input type="checkbox"/> <input type="checkbox"/> <input type="checkbox"/>	180.0#	

A **B** **C** **D** **E** **F** **G** **H**

HOW TO ORDER

Indicate the following information on order form:

- Quantity of each item.
- Model number, including options. See "How To Build a Model Number".
- Any special service required.

Note: • The indicates that a choice is required.
 • The absence of the indicates that no choice is required.
 • Alpha-numeric characters in place of indicate that no other alternatives are available.

HOW TO BUILD A MODEL NUMBER

- A** Select basic model.
- B** Select electrical code for base raceway.
 DN - Domestic, no cutouts
 D1 - Domestic, 1 side w/cutouts
 D - Domestic, 2 sides w/cutouts
- C** Select horizontal rail.
 E - Enhanced
 S - Standard
- D** Select numbers of raceway tiles side 1
 R0 - Side 1 w/no raceway tile
- E** Select numbers of raceway tiles side 2
 R20 - Side 2 w/no raceway tile
 R21 - Side 2 w/1-12" raceway tile
 R22 - Side 2 w/2-12" raceway tiles
 R23 - Side 2 w/3-12" raceway tiles
- F** Select trim color.
 Refer to the **Product Color Options** page in this catalog.
 SX Starlight Silver finish is only offered on flat aluminum trim.
- G** Select fabric side 1.
- H** Select fabric side 2.

INFORMATION

Maximum Raceway Tile Possibilities

Panel Height	Side 1	Side 2
30"H	0	0
48"H	1	1
66"H	2	2
84"H	2	2

Fabric Panel - Tackable Acoustic (3/4" Thick Tiles)

Half Segmented/Half Segmented Panel

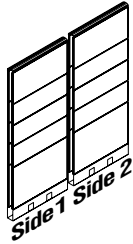

MODEL	W x H	MODEL NUMBER								Approx. Packaged Weight
		Basic Model	Electrical Code	Horizontal Rail	Number of Raceway Tiles Side 1	Number of Raceway Tiles Side 2	Trim Color	Fabric Side 1	Fabric Side 2	
Half Segmented/Half Segmented Panel - 42"H with 12"H tiles • Three to six horizontal rails • Two, four or six 12" fabric tiles with mounting hooks • Two 18" fabric tile included with 84" high panels with mounting hooks • One base/raceway consisting of a raceway pan and two doors • One rounded satin-textured polypropylene top cap with splice plate • Order power separately • Order vertical posts separately • SX Starlight Silver finish is only offered on flat aluminum trim	12 x 42"	PHHA1242	<input type="checkbox"/>	<input type="checkbox"/>	<input type="checkbox"/>	<input type="checkbox"/>	<input type="checkbox"/>	<input type="checkbox"/>	<input type="checkbox"/>	22.0#
	18 x 42"	PHHA1842	<input type="checkbox"/>	<input type="checkbox"/>	<input type="checkbox"/>	<input type="checkbox"/>	<input type="checkbox"/>	<input type="checkbox"/>	<input type="checkbox"/>	30.0#
	24 x 42"	PHHA2442	<input type="checkbox"/>	<input type="checkbox"/>	<input type="checkbox"/>	<input type="checkbox"/>	<input type="checkbox"/>	<input type="checkbox"/>	<input type="checkbox"/>	38.0#
	30 x 42"	PHHA3042	<input type="checkbox"/>	<input type="checkbox"/>	<input type="checkbox"/>	<input type="checkbox"/>	<input type="checkbox"/>	<input type="checkbox"/>	<input type="checkbox"/>	47.0#
	36 x 42"	PHHA3642	<input type="checkbox"/>	<input type="checkbox"/>	<input type="checkbox"/>	<input type="checkbox"/>	<input type="checkbox"/>	<input type="checkbox"/>	<input type="checkbox"/>	55.0#
	42 x 42"	PHHA4242	<input type="checkbox"/>	<input type="checkbox"/>	<input type="checkbox"/>	<input type="checkbox"/>	<input type="checkbox"/>	<input type="checkbox"/>	<input type="checkbox"/>	63.0#
	48 x 42"	PHHA4842	<input type="checkbox"/>	<input type="checkbox"/>	<input type="checkbox"/>	<input type="checkbox"/>	<input type="checkbox"/>	<input type="checkbox"/>	<input type="checkbox"/>	71.0#
	54 x 42"	PHHA5442	<input type="checkbox"/>	<input type="checkbox"/>	<input type="checkbox"/>	<input type="checkbox"/>	<input type="checkbox"/>	<input type="checkbox"/>	<input type="checkbox"/>	79.0#
	60 x 42"	PHHA6042	<input type="checkbox"/>	<input type="checkbox"/>	<input type="checkbox"/>	<input type="checkbox"/>	<input type="checkbox"/>	<input type="checkbox"/>	<input type="checkbox"/>	88.0#
P1HHA - KD1 PHHA - Pass Through										
Half Segmented/Half Segmented Panel - 54"H with 12"H tiles	12 x 54"	PHHA1254	<input type="checkbox"/>	<input type="checkbox"/>	<input type="checkbox"/>	<input type="checkbox"/>	<input type="checkbox"/>	<input type="checkbox"/>	<input type="checkbox"/>	24.0#
	18 x 54"	PHHA1854	<input type="checkbox"/>	<input type="checkbox"/>	<input type="checkbox"/>	<input type="checkbox"/>	<input type="checkbox"/>	<input type="checkbox"/>	<input type="checkbox"/>	33.0#
	24 x 54"	PHHA2454	<input type="checkbox"/>	<input type="checkbox"/>	<input type="checkbox"/>	<input type="checkbox"/>	<input type="checkbox"/>	<input type="checkbox"/>	<input type="checkbox"/>	43.0#
	30 x 54"	PHHA3054	<input type="checkbox"/>	<input type="checkbox"/>	<input type="checkbox"/>	<input type="checkbox"/>	<input type="checkbox"/>	<input type="checkbox"/>	<input type="checkbox"/>	52.0#
	36 x 54"	PHHA3654	<input type="checkbox"/>	<input type="checkbox"/>	<input type="checkbox"/>	<input type="checkbox"/>	<input type="checkbox"/>	<input type="checkbox"/>	<input type="checkbox"/>	61.0#
	42 x 54"	PHHA4254	<input type="checkbox"/>	<input type="checkbox"/>	<input type="checkbox"/>	<input type="checkbox"/>	<input type="checkbox"/>	<input type="checkbox"/>	<input type="checkbox"/>	70.0#
	48 x 54"	PHHA4854	<input type="checkbox"/>	<input type="checkbox"/>	<input type="checkbox"/>	<input type="checkbox"/>	<input type="checkbox"/>	<input type="checkbox"/>	<input type="checkbox"/>	79.0#
	54 x 54"	PHHA5454	<input type="checkbox"/>	<input type="checkbox"/>	<input type="checkbox"/>	<input type="checkbox"/>	<input type="checkbox"/>	<input type="checkbox"/>	<input type="checkbox"/>	88.0#
60 x 54"	PHHA6054	<input type="checkbox"/>	<input type="checkbox"/>	<input type="checkbox"/>	<input type="checkbox"/>	<input type="checkbox"/>	<input type="checkbox"/>	<input type="checkbox"/>	100.0#	

A B C D E F G H

HOW TO ORDER

Indicate the following information on order form:

- Quantity of each item.
- Model number, including options. See "How To Build a Model Number".
- Any special service required.

Note: • The indicates that a choice is required.
 • The absence of the indicates that no choice is required.
 • Alpha-numeric characters in place of indicate that no other alternatives are available.

HOW TO BUILD A MODEL NUMBER

- A** Select basic model.
- B** Select electrical code for base raceway.
 DN - Domestic, no cutouts
 D1 - Domestic, 1 side w/cutouts
 D - Domestic, 2 sides w/cutouts
- C** Select horizontal rail.
 S - Standard
 E - Enhanced
- D** Select numbers of raceway tiles side 1
 R0 - Side 1 w/no raceway tile
 R1 - Side 1 w/1-12" raceway tile
 R2 - Side 1 w/2-12" raceway tiles
- E** Select numbers of raceway tiles side 2
 R20 - Side 2 w/no raceway tile
 R21 - Side 2 w/1-12" raceway tile
 R22 - Side 2 w/2-12" raceway tiles
- F** Select trim color.
 Refer to the **Product Color Options** page in this catalog.
 SX Starlight Silver finish is only offered on flat aluminum trim.
- G** Select fabric side 1.
- H** Select fabric side 2.

INFORMATION

Maximum Raceway Tile Possibilities

Panel Height	Side 1	Side 2
42"H	1	1
54"H	2	2
66"H	2	2
84"H	2	2

Fabric Panel - Tackable Acoustic (3/4" Thick Tiles)

Half Segmented/Half Segmented Panel

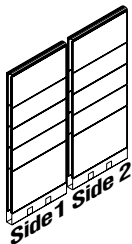

P1HHA - KD1

PHHA - Pass Through

P1HHA - KD1

PHHA - Pass Through

MODEL

W x H

MODEL NUMBER

Basic Model

Electrical Code

Horizontal Rail

Number of Raceway Tiles Side 1

Number of Raceway Tiles Side 2

Trim Color

Fabric Side 1

Fabric Side 2

Approx. Packaged Weight

Half Segmented/Half Segmented Panel - 66"H with 12"H tiles

- Three to six horizontal rails
- Two, four or six 12" fabric tiles with mounting hooks
- Two 18" fabric tile included with 84" high panels with mounting hooks
- One base/raceway consisting of a raceway pan and two doors
- One rounded satin-textured polypropylene top cap with splice plate
- Order power separately
- Order vertical posts separately
- SX Starlight Silver finish is only offered on flat aluminum trim

MODEL	W x H	Basic Model	Electrical Code	Horizontal Rail	Number of Raceway Tiles Side 1	Number of Raceway Tiles Side 2	Trim Color	Fabric Side 1	Fabric Side 2	Approx. Packaged Weight
PHHA1266	12 x 66"	<input type="checkbox"/>	<input type="checkbox"/>	<input type="checkbox"/>	<input type="checkbox"/>	<input type="checkbox"/>	<input type="checkbox"/>	<input type="checkbox"/>	<input type="checkbox"/>	37.0#
PHHA1866	18 x 66"	<input type="checkbox"/>	<input type="checkbox"/>	<input type="checkbox"/>	<input type="checkbox"/>	<input type="checkbox"/>	<input type="checkbox"/>	<input type="checkbox"/>	<input type="checkbox"/>	51.0#
PHHA2466	24 x 66"	<input type="checkbox"/>	<input type="checkbox"/>	<input type="checkbox"/>	<input type="checkbox"/>	<input type="checkbox"/>	<input type="checkbox"/>	<input type="checkbox"/>	<input type="checkbox"/>	65.0#
PHHA3066	30 x 66"	<input type="checkbox"/>	<input type="checkbox"/>	<input type="checkbox"/>	<input type="checkbox"/>	<input type="checkbox"/>	<input type="checkbox"/>	<input type="checkbox"/>	<input type="checkbox"/>	79.0#
PHHA3666	36 x 66"	<input type="checkbox"/>	<input type="checkbox"/>	<input type="checkbox"/>	<input type="checkbox"/>	<input type="checkbox"/>	<input type="checkbox"/>	<input type="checkbox"/>	<input type="checkbox"/>	92.0#
PHHA4266	42 x 66"	<input type="checkbox"/>	<input type="checkbox"/>	<input type="checkbox"/>	<input type="checkbox"/>	<input type="checkbox"/>	<input type="checkbox"/>	<input type="checkbox"/>	<input type="checkbox"/>	106.0#
PHHA4866	48 x 66"	<input type="checkbox"/>	<input type="checkbox"/>	<input type="checkbox"/>	<input type="checkbox"/>	<input type="checkbox"/>	<input type="checkbox"/>	<input type="checkbox"/>	<input type="checkbox"/>	119.0#
PHHA5466	54 x 66"	<input type="checkbox"/>	<input type="checkbox"/>	<input type="checkbox"/>	<input type="checkbox"/>	<input type="checkbox"/>	<input type="checkbox"/>	<input type="checkbox"/>	<input type="checkbox"/>	133.0#
PHHA6066	60 x 66"	<input type="checkbox"/>	<input type="checkbox"/>	<input type="checkbox"/>	<input type="checkbox"/>	<input type="checkbox"/>	<input type="checkbox"/>	<input type="checkbox"/>	<input type="checkbox"/>	150.0#

Half Segmented/Half Segmented Panel - 84"H with 12"H tiles

MODEL	W x H	Basic Model	Electrical Code	Horizontal Rail	Number of Raceway Tiles Side 1	Number of Raceway Tiles Side 2	Trim Color	Fabric Side 1	Fabric Side 2	Approx. Packaged Weight
PHHA1284	12 x 84"	<input type="checkbox"/>	<input type="checkbox"/>	<input type="checkbox"/>	<input type="checkbox"/>	<input type="checkbox"/>	<input type="checkbox"/>	<input type="checkbox"/>	<input type="checkbox"/>	43.0#
PHHA1884	18 x 84"	<input type="checkbox"/>	<input type="checkbox"/>	<input type="checkbox"/>	<input type="checkbox"/>	<input type="checkbox"/>	<input type="checkbox"/>	<input type="checkbox"/>	<input type="checkbox"/>	59.0#
PHHA2484	24 x 84"	<input type="checkbox"/>	<input type="checkbox"/>	<input type="checkbox"/>	<input type="checkbox"/>	<input type="checkbox"/>	<input type="checkbox"/>	<input type="checkbox"/>	<input type="checkbox"/>	75.0#
PHHA3084	30 x 84"	<input type="checkbox"/>	<input type="checkbox"/>	<input type="checkbox"/>	<input type="checkbox"/>	<input type="checkbox"/>	<input type="checkbox"/>	<input type="checkbox"/>	<input type="checkbox"/>	91.0#
PHHA3684	36 x 84"	<input type="checkbox"/>	<input type="checkbox"/>	<input type="checkbox"/>	<input type="checkbox"/>	<input type="checkbox"/>	<input type="checkbox"/>	<input type="checkbox"/>	<input type="checkbox"/>	106.0#
PHHA4284	42 x 84"	<input type="checkbox"/>	<input type="checkbox"/>	<input type="checkbox"/>	<input type="checkbox"/>	<input type="checkbox"/>	<input type="checkbox"/>	<input type="checkbox"/>	<input type="checkbox"/>	122.0#
PHHA4884	48 x 84"	<input type="checkbox"/>	<input type="checkbox"/>	<input type="checkbox"/>	<input type="checkbox"/>	<input type="checkbox"/>	<input type="checkbox"/>	<input type="checkbox"/>	<input type="checkbox"/>	137.0#
PHHA5484	54 x 84"	<input type="checkbox"/>	<input type="checkbox"/>	<input type="checkbox"/>	<input type="checkbox"/>	<input type="checkbox"/>	<input type="checkbox"/>	<input type="checkbox"/>	<input type="checkbox"/>	153.0#
PHHA6084	60 x 84"	<input type="checkbox"/>	<input type="checkbox"/>	<input type="checkbox"/>	<input type="checkbox"/>	<input type="checkbox"/>	<input type="checkbox"/>	<input type="checkbox"/>	<input type="checkbox"/>	172.0#

A B C D E F G H

HOW TO ORDER

Indicate the following information on order form:

1. Quantity of each item.
2. Model number, including options. See "How To Build a Model Number".
3. Any special service required.

Note: • The indicates that a choice is required.
 • The absence of the indicates that no choice is required.
 • Alpha-numeric characters in place of indicate that no other alternatives are available.

HOW TO BUILD A MODEL NUMBER

- A** Select basic model.
- B** Select electrical code for base raceway.
 - DN - Domestic, no cutouts
 - D1 - Domestic, 1 side w/cutouts
 - D - Domestic, 2 sides w/cutouts
- C** Select horizontal rail.
 - S - Standard
 - E - Enhanced
- D** Select numbers of raceway tiles side 1
 - R0 - Side 1 w/no raceway tile
 - R1 - Side 1 w/1-12" raceway tile
 - R2 - Side 1 w/2-12" raceway tiles
- E** Select numbers of raceway tiles side 2
 - R20 - Side 2 w/no raceway tile
 - R21 - Side 2 w/1-12" raceway tile
 - R22 - Side 2 w/2-12" raceway tiles
- F** Select trim color. Refer to the **Product Color Options** page in this catalog. SX Starlight Silver finish is only offered on flat aluminum trim.
- G** Select fabric side 1.
- H** Select fabric side 2.

INFORMATION

Maximum Raceway Tile Possibilities

Panel Height	Side 1	Side 2
42"H	1	1
54"H	2	2
66"H	2	2
84"H	2	2

Fabric Panel - Tackable Acoustic (3/4" Thick Tiles)

Half Segmented/Fully Segmented Panel

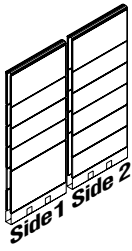
MODEL	W x H	MODEL NUMBER								Approx. Packaged Weight	
		Basic Model	Electrical Code	Horizontal Rail	Number of Raceway Tiles Side 1	Number of Raceway Tiles Side 2	Trim Color	Fabric Side 1	Fabric Side 2		
 <p>P1HFA - KD1 PHFA - Pass Through</p>	Half Segmented/Fully Segmented Panel - 42"H with 12"H tiles	12 x 42"	PHFA1242	<input type="checkbox"/>	<input type="checkbox"/>	<input type="checkbox"/>	<input type="checkbox"/>	<input type="checkbox"/>	<input type="checkbox"/>	<input type="checkbox"/>	23.0#
		18 x 42"	PHFA1842	<input type="checkbox"/>	<input type="checkbox"/>	<input type="checkbox"/>	<input type="checkbox"/>	<input type="checkbox"/>	<input type="checkbox"/>	<input type="checkbox"/>	32.0#
	• Three to seven horizontal rails	24 x 42"	PHFA2442	<input type="checkbox"/>	<input type="checkbox"/>	<input type="checkbox"/>	<input type="checkbox"/>	<input type="checkbox"/>	<input type="checkbox"/>	<input type="checkbox"/>	41.0#
	• Four, six or eight 12" fabric tiles with mounting hooks	30 x 42"	PHFA3042	<input type="checkbox"/>	<input type="checkbox"/>	<input type="checkbox"/>	<input type="checkbox"/>	<input type="checkbox"/>	<input type="checkbox"/>	<input type="checkbox"/>	49.0#
	• Two 18" fabric tiles included with 84" high panels with mounting hooks	36 x 42"	PHFA3642	<input type="checkbox"/>	<input type="checkbox"/>	<input type="checkbox"/>	<input type="checkbox"/>	<input type="checkbox"/>	<input type="checkbox"/>	<input type="checkbox"/>	58.0#
	• One base/raceway consisting of a raceway pan and two doors	42 x 42"	PHFA4242	<input type="checkbox"/>	<input type="checkbox"/>	<input type="checkbox"/>	<input type="checkbox"/>	<input type="checkbox"/>	<input type="checkbox"/>	<input type="checkbox"/>	66.0#
	• One rounded satin-textured polypropylene top cap with splice plate	48 x 42"	PHFA4842	<input type="checkbox"/>	<input type="checkbox"/>	<input type="checkbox"/>	<input type="checkbox"/>	<input type="checkbox"/>	<input type="checkbox"/>	<input type="checkbox"/>	75.0#
	• One rounded satin-textured polypropylene top cap with splice plate	54 x 42"	PHFA5442	<input type="checkbox"/>	<input type="checkbox"/>	<input type="checkbox"/>	<input type="checkbox"/>	<input type="checkbox"/>	<input type="checkbox"/>	<input type="checkbox"/>	84.0#
	• Order power separately	60 x 42"	PHFA6042	<input type="checkbox"/>	<input type="checkbox"/>	<input type="checkbox"/>	<input type="checkbox"/>	<input type="checkbox"/>	<input type="checkbox"/>	<input type="checkbox"/>	94.0#
	• Order vertical posts separately										
• SX Starlight Silver finish is only offered on flat aluminum trim											
<p>P1HFA - KD1 PHFA - Pass Through</p>	Half Segmented/Fully Segmented Panel - 54"H with 12"H tiles	12 x 54"	PHFA1254	<input type="checkbox"/>	<input type="checkbox"/>	<input type="checkbox"/>	<input type="checkbox"/>	<input type="checkbox"/>	<input type="checkbox"/>	<input type="checkbox"/>	32.0#
		18 x 54"	PHFA1854	<input type="checkbox"/>	<input type="checkbox"/>	<input type="checkbox"/>	<input type="checkbox"/>	<input type="checkbox"/>	<input type="checkbox"/>	<input type="checkbox"/>	45.0#
		24 x 54"	PHFA2454	<input type="checkbox"/>	<input type="checkbox"/>	<input type="checkbox"/>	<input type="checkbox"/>	<input type="checkbox"/>	<input type="checkbox"/>	<input type="checkbox"/>	58.0#
		30 x 54"	PHFA3054	<input type="checkbox"/>	<input type="checkbox"/>	<input type="checkbox"/>	<input type="checkbox"/>	<input type="checkbox"/>	<input type="checkbox"/>	<input type="checkbox"/>	71.0#
		36 x 54"	PHFA3654	<input type="checkbox"/>	<input type="checkbox"/>	<input type="checkbox"/>	<input type="checkbox"/>	<input type="checkbox"/>	<input type="checkbox"/>	<input type="checkbox"/>	83.0#
		42 x 54"	PHFA4254	<input type="checkbox"/>	<input type="checkbox"/>	<input type="checkbox"/>	<input type="checkbox"/>	<input type="checkbox"/>	<input type="checkbox"/>	<input type="checkbox"/>	96.0#
		48 x 54"	PHFA4854	<input type="checkbox"/>	<input type="checkbox"/>	<input type="checkbox"/>	<input type="checkbox"/>	<input type="checkbox"/>	<input type="checkbox"/>	<input type="checkbox"/>	108.0#
		54 x 54"	PHFA5454	<input type="checkbox"/>	<input type="checkbox"/>	<input type="checkbox"/>	<input type="checkbox"/>	<input type="checkbox"/>	<input type="checkbox"/>	<input type="checkbox"/>	120.0#
	60 x 54"	PHFA6054	<input type="checkbox"/>	<input type="checkbox"/>	<input type="checkbox"/>	<input type="checkbox"/>	<input type="checkbox"/>	<input type="checkbox"/>	<input type="checkbox"/>	136.0#	
				A	B	C	D	E	F	G	H

HOW TO ORDER

Indicate the following information on order form:

- Quantity of each item.
- Model number, including options. See "How To Build a Model Number".
- Any special service required.

Note: • The indicates that a choice is required.
• The absence of the indicates that no choice is required.
• Alpha-numeric characters in place of indicate that no other alternatives are available.

HOW TO BUILD A MODEL NUMBER

- A** Select basic model.
- B** Select electrical code for base raceway.
 - DN** - Domestic, no cutouts
 - D1** - Domestic, 1 side w/cutouts
 - D** - Domestic, 2 sides w/cutouts
- C** Select horizontal rail.
 - E** - Enhanced
 - S** - Standard
- D** Select numbers of raceway tiles side 1
 - R0** - Side 1 w/no raceway tile
 - R1** - Side 1 w/1-12" raceway tile
 - R2** - Side 1 w/2-12" raceway tiles
- E** Select numbers of raceway tiles side 2
 - R20** - Side 2 w/no raceway tile
 - R21** - Side 2 w/1-12" raceway tile
 - R22** - Side 2 w/2-12" raceway tiles
 - R23** - Side 2 w/3-12" raceway tiles
- F** Select trim color. Refer to the **Product Color Options** page in this catalog. SX Starlight Silver finish is only offered on flat aluminum trim.
- G** Select fabric side 1.
- H** Select fabric side 2.

INFORMATION

Maximum Raceway Tile Possibilities

Panel Height	Side 1	Side 2
42"H	1	2
54"H	2	3
66"H	2	3
84"H	2	3

Fabric Panel - Tackable Acoustic (3/4" Thick Tiles)

Half Segmented/Fully Segmented Panel

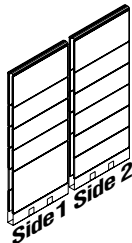

P1HFA - KD1
PHFA - Pass Through

MODEL

W x H

MODEL NUMBER

Basic Model	Electrical Code	Horizontal Rail	Number of Raceway Tiles Side 1	Number of Raceway Tiles Side 2	Trim Color	Fabric Side 1	Fabric Side 2	Approx. Packaged Weight
PHFA1266	<input type="checkbox"/>	<input type="checkbox"/>	<input type="checkbox"/>	<input type="checkbox"/>	<input type="checkbox"/>	<input type="checkbox"/>	<input type="checkbox"/>	40.0#
PHFA1866	<input type="checkbox"/>	<input type="checkbox"/>	<input type="checkbox"/>	<input type="checkbox"/>	<input type="checkbox"/>	<input type="checkbox"/>	<input type="checkbox"/>	56.0#
PHFA2466	<input type="checkbox"/>	<input type="checkbox"/>	<input type="checkbox"/>	<input type="checkbox"/>	<input type="checkbox"/>	<input type="checkbox"/>	<input type="checkbox"/>	72.0#
PHFA3066	<input type="checkbox"/>	<input type="checkbox"/>	<input type="checkbox"/>	<input type="checkbox"/>	<input type="checkbox"/>	<input type="checkbox"/>	<input type="checkbox"/>	87.0#
PHFA3666	<input type="checkbox"/>	<input type="checkbox"/>	<input type="checkbox"/>	<input type="checkbox"/>	<input type="checkbox"/>	<input type="checkbox"/>	<input type="checkbox"/>	102.0#
PHFA4266	<input type="checkbox"/>	<input type="checkbox"/>	<input type="checkbox"/>	<input type="checkbox"/>	<input type="checkbox"/>	<input type="checkbox"/>	<input type="checkbox"/>	117.0#
PHFA4866	<input type="checkbox"/>	<input type="checkbox"/>	<input type="checkbox"/>	<input type="checkbox"/>	<input type="checkbox"/>	<input type="checkbox"/>	<input type="checkbox"/>	132.0#
PHFA5466	<input type="checkbox"/>	<input type="checkbox"/>	<input type="checkbox"/>	<input type="checkbox"/>	<input type="checkbox"/>	<input type="checkbox"/>	<input type="checkbox"/>	148.0#
PHFA6066	<input type="checkbox"/>	<input type="checkbox"/>	<input type="checkbox"/>	<input type="checkbox"/>	<input type="checkbox"/>	<input type="checkbox"/>	<input type="checkbox"/>	166.0#
PHFA1284	<input type="checkbox"/>	<input type="checkbox"/>	<input type="checkbox"/>	<input type="checkbox"/>	<input type="checkbox"/>	<input type="checkbox"/>	<input type="checkbox"/>	46.0#
PHFA1884	<input type="checkbox"/>	<input type="checkbox"/>	<input type="checkbox"/>	<input type="checkbox"/>	<input type="checkbox"/>	<input type="checkbox"/>	<input type="checkbox"/>	63.0#
PHFA2484	<input type="checkbox"/>	<input type="checkbox"/>	<input type="checkbox"/>	<input type="checkbox"/>	<input type="checkbox"/>	<input type="checkbox"/>	<input type="checkbox"/>	81.0#
PHFA3084	<input type="checkbox"/>	<input type="checkbox"/>	<input type="checkbox"/>	<input type="checkbox"/>	<input type="checkbox"/>	<input type="checkbox"/>	<input type="checkbox"/>	99.0#
PHFA3684	<input type="checkbox"/>	<input type="checkbox"/>	<input type="checkbox"/>	<input type="checkbox"/>	<input type="checkbox"/>	<input type="checkbox"/>	<input type="checkbox"/>	116.0#
PHFA4284	<input type="checkbox"/>	<input type="checkbox"/>	<input type="checkbox"/>	<input type="checkbox"/>	<input type="checkbox"/>	<input type="checkbox"/>	<input type="checkbox"/>	133.0#
PHFA4884	<input type="checkbox"/>	<input type="checkbox"/>	<input type="checkbox"/>	<input type="checkbox"/>	<input type="checkbox"/>	<input type="checkbox"/>	<input type="checkbox"/>	151.0#
PHFA5484	<input type="checkbox"/>	<input type="checkbox"/>	<input type="checkbox"/>	<input type="checkbox"/>	<input type="checkbox"/>	<input type="checkbox"/>	<input type="checkbox"/>	168.0#
PHFA6084	<input type="checkbox"/>	<input type="checkbox"/>	<input type="checkbox"/>	<input type="checkbox"/>	<input type="checkbox"/>	<input type="checkbox"/>	<input type="checkbox"/>	189.0#

A B C D E F G H

Half Segmented/Fully Segmented Panel - 66"H with 12"H tiles

- Three to seven horizontal rails
- Four, six or eight 12" fabric tiles with mounting hooks
- Two 18" fabric tiles included with 84" high panels with mounting hooks
- One base/raceway consisting of a raceway pan and two doors
- One rounded satin-textured polypropylene top cap with splice plate
- Order power separately
- Order vertical posts separately
- SX Starlight Silver finish is only offered on flat aluminum trim

Half Segmented/Fully Segmented Panel - 84"H with 12"H tiles

HOW TO ORDER

Indicate the following information on order form:

1. Quantity of each item.
2. Model number, including options. See "How To Build a Model Number".
3. Any special service required.

Note: • The indicates that a choice is required.
• The absence of the indicates that no choice is required.
• Alpha-numeric characters in place of indicate that no other alternatives are available.

HOW TO BUILD A MODEL NUMBER

- A** Select basic model.
- B** Select electrical code for base raceway.
 - DN** - Domestic, no cutouts
 - D1** - Domestic, 1 side w/cutouts
 - D** - Domestic, 2 sides w/cutouts
- C** Select horizontal rail.
 - E** - Enhanced
 - S** - Standard
- D** Select numbers of raceway tiles side 1
 - R0** - Side 1 w/no raceway tile
 - R1** - Side 1 w/1-12" raceway tile
 - R2** - Side 1 w/2-12" raceway tiles
- E** Select numbers of raceway tiles side 2
 - R20** - Side 2 w/no raceway tile
 - R21** - Side 2 w/1-12" raceway tile
 - R22** - Side 2 w/2-12" raceway tiles
 - R23** - Side 2 w/3-12" raceway tiles
- F** Select trim color. Refer to the **Product Color Options** page in this catalog. SX Starlight Silver finish is only offered on flat aluminum trim.
- G** Select fabric side 1.
- H** Select fabric side 2.

INFORMATION

Maximum Raceway Tile Possibilities

Panel Height	Side 1	Side 2
42"H	1	2
54"H	2	3
66"H	2	3
84"H	2	3

Fabric Panel - Tackable Acoustic (3/4" Thick Tiles)

Fully Segmented/Fully Segmented Panel

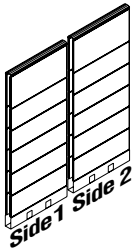
MODEL	W x H	MODEL NUMBER								Approx. Packaged Weight	
		Basic Model	Electrical Code	Horizontal Rail	Number of Raceway Tiles Side 1	Number of Raceway Tiles Side 2	Trim Color	Fabric Side 1	Fabric Side 2		
 <p>P1FFA - KD1 PFFA - Pass Through</p>	Fully Segmented/Fully Segmented Panel - 30"H with 12"H tiles	12 x 30"	PFFA1230	<input type="checkbox"/>	<input type="checkbox"/>	<input type="checkbox"/>	<input type="checkbox"/>	<input type="checkbox"/>	<input type="checkbox"/>	<input type="checkbox"/>	19.0#
	18 x 30"	PFFA1830	<input type="checkbox"/>	<input type="checkbox"/>	<input type="checkbox"/>	<input type="checkbox"/>	<input type="checkbox"/>	<input type="checkbox"/>	<input type="checkbox"/>	<input type="checkbox"/>	26.0#
	• Three to seven horizontal rails	24 x 30"	PFFA2430	<input type="checkbox"/>	<input type="checkbox"/>	<input type="checkbox"/>	<input type="checkbox"/>	<input type="checkbox"/>	<input type="checkbox"/>	<input type="checkbox"/>	34.0#
	• Four, six or eight 12" fabric tiles with mounting hooks	30 x 30"	PFFA3030	<input type="checkbox"/>	<input type="checkbox"/>	<input type="checkbox"/>	<input type="checkbox"/>	<input type="checkbox"/>	<input type="checkbox"/>	<input type="checkbox"/>	41.0#
	• Two 18" fabric tile included with 84" high panels with mounting hooks	36 x 30"	PFFA3630	<input type="checkbox"/>	<input type="checkbox"/>	<input type="checkbox"/>	<input type="checkbox"/>	<input type="checkbox"/>	<input type="checkbox"/>	<input type="checkbox"/>	49.0#
	• One base/raceway consisting of a raceway pan and two doors	42 x 30"	PFFA4230	<input type="checkbox"/>	<input type="checkbox"/>	<input type="checkbox"/>	<input type="checkbox"/>	<input type="checkbox"/>	<input type="checkbox"/>	<input type="checkbox"/>	56.0#
	• One rounded satin-textured polypropylene top cap with splice plate	48 x 30"	PFFA4830	<input type="checkbox"/>	<input type="checkbox"/>	<input type="checkbox"/>	<input type="checkbox"/>	<input type="checkbox"/>	<input type="checkbox"/>	<input type="checkbox"/>	63.0#
	• One rounded satin-textured polypropylene top cap with splice plate	54 x 30"	PFFA5430	<input type="checkbox"/>	<input type="checkbox"/>	<input type="checkbox"/>	<input type="checkbox"/>	<input type="checkbox"/>	<input type="checkbox"/>	<input type="checkbox"/>	71.0#
	• Order power separately	60 x 30"	PFFA6030	<input type="checkbox"/>	<input type="checkbox"/>	<input type="checkbox"/>	<input type="checkbox"/>	<input type="checkbox"/>	<input type="checkbox"/>	<input type="checkbox"/>	80.0#
	• Order vertical posts separately										
• SX Starlight Silver finish is only offered on flat aluminum trim											
<p>P1FFA - KD1 PFFA - Pass Through</p>	Fully Segmented/Fully Segmented Panel - 42"H with 12"H tiles	12 x 42"	PFFA1242	<input type="checkbox"/>	<input type="checkbox"/>	<input type="checkbox"/>	<input type="checkbox"/>	<input type="checkbox"/>	<input type="checkbox"/>	<input type="checkbox"/>	26.0#
	18 x 42"	PFFA1842	<input type="checkbox"/>	<input type="checkbox"/>	<input type="checkbox"/>	<input type="checkbox"/>	<input type="checkbox"/>	<input type="checkbox"/>	<input type="checkbox"/>	<input type="checkbox"/>	36.0#
	24 x 42"	PFFA2442	<input type="checkbox"/>	<input type="checkbox"/>	<input type="checkbox"/>	<input type="checkbox"/>	<input type="checkbox"/>	<input type="checkbox"/>	<input type="checkbox"/>	<input type="checkbox"/>	47.0#
	30 x 42"	PFFA3042	<input type="checkbox"/>	<input type="checkbox"/>	<input type="checkbox"/>	<input type="checkbox"/>	<input type="checkbox"/>	<input type="checkbox"/>	<input type="checkbox"/>	<input type="checkbox"/>	57.0#
	36 x 42"	PFFA3642	<input type="checkbox"/>	<input type="checkbox"/>	<input type="checkbox"/>	<input type="checkbox"/>	<input type="checkbox"/>	<input type="checkbox"/>	<input type="checkbox"/>	<input type="checkbox"/>	68.0#
	42 x 42"	PFFA4242	<input type="checkbox"/>	<input type="checkbox"/>	<input type="checkbox"/>	<input type="checkbox"/>	<input type="checkbox"/>	<input type="checkbox"/>	<input type="checkbox"/>	<input type="checkbox"/>	77.0#
	48 x 42"	PFFA4842	<input type="checkbox"/>	<input type="checkbox"/>	<input type="checkbox"/>	<input type="checkbox"/>	<input type="checkbox"/>	<input type="checkbox"/>	<input type="checkbox"/>	<input type="checkbox"/>	88.0#
	54 x 42"	PFFA5442	<input type="checkbox"/>	<input type="checkbox"/>	<input type="checkbox"/>	<input type="checkbox"/>	<input type="checkbox"/>	<input type="checkbox"/>	<input type="checkbox"/>	<input type="checkbox"/>	98.0#
60 x 42"	PFFA6042	<input type="checkbox"/>	<input type="checkbox"/>	<input type="checkbox"/>	<input type="checkbox"/>	<input type="checkbox"/>	<input type="checkbox"/>	<input type="checkbox"/>	<input type="checkbox"/>	110.0#	

A B C D E F G H

HOW TO ORDER

Indicate the following information on order form:

- Quantity of each item.
- Model number, including options. See "How To Build a Model Number".
- Any special service required.

Note: • The indicates that a choice is required.
• The absence of the indicates that no choice is required.
• Alpha-numeric characters in place of indicate that no other alternatives are available.

HOW TO BUILD A MODEL NUMBER

- A** Select basic model.
- B** Select electrical code for base raceway.
 - DN** - Domestic, no cutouts
 - D1** - Domestic, 1 side w/cutouts
 - D** - Domestic, 2 sides w/cutouts
- C** Select horizontal rail.
 - E** - Enhanced
 - S** - Standard
- D** Select numbers of raceway tiles side 1
 - R0** - Side 1 w/no raceway tile
 - R1** - Side 1 w/1-12" raceway tile
 - R2** - Side 1 w/2-12" raceway tiles
 - R3** - Side 1 w/3 12" raceway tiles
- E** Select numbers of raceway tiles side 2
 - R20** - Side 2 w/no raceway tile
 - R21** - Side 2 w/1-12" raceway tile
 - R22** - Side 2 w/2-12" raceway tiles
 - R23** - Side 2 w/3-12" raceway tiles
- F** Select trim color. Refer to the **Product Color Options** page in this catalog. SX Starlight Silver finish is only offered on flat aluminum trim.
- G** Select fabric side 1.
- H** Select fabric side 2.

INFORMATION

Maximum Raceway Tile Possibilities

Panel Height	Side 1	Side 2
30"H	1	1
42"H	2	2
48"H	3	3
66"H	3	3
84"H	3	3

Fabric Panel - Tackable Acoustic (3/4" Thick Tiles)

Fully Segmented/Fully Segmented Panel

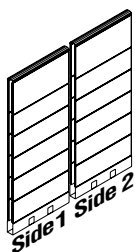

P1FFA - KD1
PFFA - Pass Through

MODEL

MODEL NUMBER

MODEL	W x H	Basic Model	Electrical Code	Horizontal Rail	Number of Raceway Tiles Side 1	Number of Raceway Tiles Side 2	Trim Color	Fabric Side 1	Fabric Side 2	Approx. Packaged Weight
Fully Segmented/Fully Segmented Panel - 54"H with 12"H tiles • Three to seven horizontal rails • Four, six or eight 12" fabric tiles with mounting hooks • Two 18" fabric tile included with 84" high panels with mounting hooks • One base/raceway consisting of a raceway pan and two doors • One rounded satin-textured polypropylene top cap with splice plate • Order power separately • Order vertical posts separately • SX Starlight Silver finish is only offered on flat aluminum trim	12 x 54"	PFFA1254	<input type="checkbox"/>	<input type="checkbox"/>	<input type="checkbox"/>	<input type="checkbox"/>	<input type="checkbox"/>	<input type="checkbox"/>	<input type="checkbox"/>	34.0#
	18 x 54"	PFFA1854	<input type="checkbox"/>	<input type="checkbox"/>	<input type="checkbox"/>	<input type="checkbox"/>	<input type="checkbox"/>	<input type="checkbox"/>	<input type="checkbox"/>	47.0#
	24 x 54"	PFFA2454	<input type="checkbox"/>	<input type="checkbox"/>	<input type="checkbox"/>	<input type="checkbox"/>	<input type="checkbox"/>	<input type="checkbox"/>	<input type="checkbox"/>	60.0#
	30 x 54"	PFFA3054	<input type="checkbox"/>	<input type="checkbox"/>	<input type="checkbox"/>	<input type="checkbox"/>	<input type="checkbox"/>	<input type="checkbox"/>	<input type="checkbox"/>	73.0#
	36 x 54"	PFFA3654	<input type="checkbox"/>	<input type="checkbox"/>	<input type="checkbox"/>	<input type="checkbox"/>	<input type="checkbox"/>	<input type="checkbox"/>	<input type="checkbox"/>	86.0#
	42 x 54"	PFFA4254	<input type="checkbox"/>	<input type="checkbox"/>	<input type="checkbox"/>	<input type="checkbox"/>	<input type="checkbox"/>	<input type="checkbox"/>	<input type="checkbox"/>	99.0#
	48 x 54"	PFFA4854	<input type="checkbox"/>	<input type="checkbox"/>	<input type="checkbox"/>	<input type="checkbox"/>	<input type="checkbox"/>	<input type="checkbox"/>	<input type="checkbox"/>	112.0#
	54 x 54"	PFFA5454	<input type="checkbox"/>	<input type="checkbox"/>	<input type="checkbox"/>	<input type="checkbox"/>	<input type="checkbox"/>	<input type="checkbox"/>	<input type="checkbox"/>	125.0#
	60 x 54"	PFFA6054	<input type="checkbox"/>	<input type="checkbox"/>	<input type="checkbox"/>	<input type="checkbox"/>	<input type="checkbox"/>	<input type="checkbox"/>	<input type="checkbox"/>	141.0#
Fully Segmented/Fully Segmented Panel - 66"H with 12"H tiles	12 x 66"	PFFA1266	<input type="checkbox"/>	<input type="checkbox"/>	<input type="checkbox"/>	<input type="checkbox"/>	<input type="checkbox"/>	<input type="checkbox"/>	<input type="checkbox"/>	41.0#
	18 x 66"	PFFA1866	<input type="checkbox"/>	<input type="checkbox"/>	<input type="checkbox"/>	<input type="checkbox"/>	<input type="checkbox"/>	<input type="checkbox"/>	<input type="checkbox"/>	57.0#
	24 x 66"	PFFA2466	<input type="checkbox"/>	<input type="checkbox"/>	<input type="checkbox"/>	<input type="checkbox"/>	<input type="checkbox"/>	<input type="checkbox"/>	<input type="checkbox"/>	74.0#
	30 x 66"	PFFA3066	<input type="checkbox"/>	<input type="checkbox"/>	<input type="checkbox"/>	<input type="checkbox"/>	<input type="checkbox"/>	<input type="checkbox"/>	<input type="checkbox"/>	89.0#
	36 x 66"	PFFA3666	<input type="checkbox"/>	<input type="checkbox"/>	<input type="checkbox"/>	<input type="checkbox"/>	<input type="checkbox"/>	<input type="checkbox"/>	<input type="checkbox"/>	105.0#
	42 x 66"	PFFA4266	<input type="checkbox"/>	<input type="checkbox"/>	<input type="checkbox"/>	<input type="checkbox"/>	<input type="checkbox"/>	<input type="checkbox"/>	<input type="checkbox"/>	120.0#
	48 x 66"	PFFA4866	<input type="checkbox"/>	<input type="checkbox"/>	<input type="checkbox"/>	<input type="checkbox"/>	<input type="checkbox"/>	<input type="checkbox"/>	<input type="checkbox"/>	134.0#
	54 x 66"	PFFA5466	<input type="checkbox"/>	<input type="checkbox"/>	<input type="checkbox"/>	<input type="checkbox"/>	<input type="checkbox"/>	<input type="checkbox"/>	<input type="checkbox"/>	152.0#
60 x 66"	PFFA6066	<input type="checkbox"/>	<input type="checkbox"/>	<input type="checkbox"/>	<input type="checkbox"/>	<input type="checkbox"/>	<input type="checkbox"/>	<input type="checkbox"/>	172.0#	
Fully Segmented/Fully Segmented Panel - 84"H with 12"H tiles	12 x 84"	PFFA1284	<input type="checkbox"/>	<input type="checkbox"/>	<input type="checkbox"/>	<input type="checkbox"/>	<input type="checkbox"/>	<input type="checkbox"/>	<input type="checkbox"/>	47.0#
	18 x 84"	PFFA1884	<input type="checkbox"/>	<input type="checkbox"/>	<input type="checkbox"/>	<input type="checkbox"/>	<input type="checkbox"/>	<input type="checkbox"/>	<input type="checkbox"/>	65.0#
	24 x 84"	PFFA2484	<input type="checkbox"/>	<input type="checkbox"/>	<input type="checkbox"/>	<input type="checkbox"/>	<input type="checkbox"/>	<input type="checkbox"/>	<input type="checkbox"/>	83.0#
	30 x 84"	PFFA3084	<input type="checkbox"/>	<input type="checkbox"/>	<input type="checkbox"/>	<input type="checkbox"/>	<input type="checkbox"/>	<input type="checkbox"/>	<input type="checkbox"/>	101.0#
	36 x 84"	PFFA3684	<input type="checkbox"/>	<input type="checkbox"/>	<input type="checkbox"/>	<input type="checkbox"/>	<input type="checkbox"/>	<input type="checkbox"/>	<input type="checkbox"/>	119.0#
	42 x 84"	PFFA4284	<input type="checkbox"/>	<input type="checkbox"/>	<input type="checkbox"/>	<input type="checkbox"/>	<input type="checkbox"/>	<input type="checkbox"/>	<input type="checkbox"/>	137.0#
	48 x 84"	PFFA4884	<input type="checkbox"/>	<input type="checkbox"/>	<input type="checkbox"/>	<input type="checkbox"/>	<input type="checkbox"/>	<input type="checkbox"/>	<input type="checkbox"/>	155.0#
	54 x 84"	PFFA5484	<input type="checkbox"/>	<input type="checkbox"/>	<input type="checkbox"/>	<input type="checkbox"/>	<input type="checkbox"/>	<input type="checkbox"/>	<input type="checkbox"/>	173.0#
60 x 84"	PFFA6084	<input type="checkbox"/>	<input type="checkbox"/>	<input type="checkbox"/>	<input type="checkbox"/>	<input type="checkbox"/>	<input type="checkbox"/>	<input type="checkbox"/>	195.0#	

A B C D E F G H

HOW TO ORDER

Indicate the following information on order form:

- Quantity of each item.
- Model number, including options. See "How To Build a Model Number".
- Any special service required.

Note: • The indicates that a choice is required.
 • The absence of the indicates that no choice is required.
 • Alpha-numeric characters in place of indicate that no other alternatives are available.

HOW TO BUILD A MODEL NUMBER

- A** Select basic model.
- B** Select electrical code for base raceway.
 DN - Domestic, no cutouts
 D1 - Domestic, 1 side w/cutouts
 D - Domestic, 2 sides w/cutouts
- C** Select horizontal rail.
 E - Enhanced
 S - Standard
- D** Select numbers of raceway tiles side 1
 R0 - Side 1 w/no raceway tile
 R1 - Side 1 w/1-12" raceway tile
 R2 - Side 1 w/2-12" raceway tiles
 R3 - Side 1 w/3 12" raceway tiles
- E** Select numbers of raceway tiles side 2
 R20 - Side 2 w/no raceway tile
 R21 - Side 2 w/1-12" raceway tile
 R22 - Side 2 w/2-12" raceway tiles
 R23 - Side 2 w/3-12" raceway tiles
- F** Select trim color.
 Refer to the **Product Color Options** page in this catalog.
 SX Starlight Silver finish is only offered on flat aluminum trim.
- G** Select fabric side 1.
- H** Select fabric side 2.

INFORMATION

Maximum Raceway Tile Possibilities

Panel Height	Side 1	Side 2
30"H	1	1
42"H	2	2
48"H	3	3
66"H	3	3
84"H	3	3

Glass Panel

Face Styles

Face Style: Full Glass

Basic Model: P1G - KD1

Basic Model: PG-Pass Through

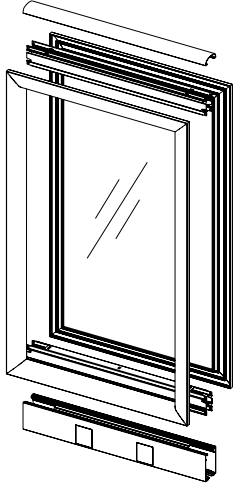

Full Glass panel consist of a full-sized glass tile. Consists of one glass tile utilizing a single panel of 1/4" thick tempered glass. Base is 6". Panel thickness: 3 1/2".

STANDARD PANEL SIZES (Glass Panels)

	12" W	18" W	24" W	30" W	36" W	42" W	48" W	54" W	60" W	Side 1 Number of	Side 2 Number of
	12" Fabric Tiles	12" Fabric Tiles	12" Fabric Tiles	12" Fabric Tiles	12" Fabric Tiles	12" Fabric Tiles	12" Fabric Tiles	12" Fabric Tiles	12" Fabric Tiles	12" Fabric Tiles	12" Fabric Tiles
30" H	N/A	N/A	N/A	N/A	N/A	N/A	N/A	N/A	N/A	N/A	N/A
42" H	N/A	N/A	N/A	N/A	N/A	N/A	N/A	N/A	N/A	N/A	N/A
54" H	•	•	•	•	•	•	•	N/A	N/A	N/A	N/A
66" H	•	•	•	•	•	•	•	N/A	N/A	N/A	N/A
84" H	•	•	•	•	•	•	•	N/A	N/A	N/A	N/A

Face Style: Glass/Monolithic

Basic Model: P1MMGA - KD1

Basic Model: PMMGA-Pass Through

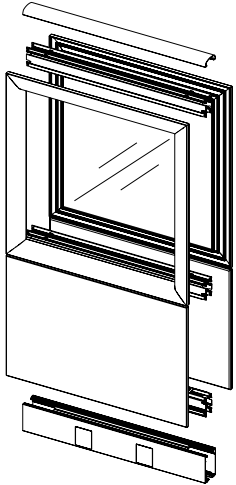

Glass/Monolithic panels consist of the following: 24" fabric tile on bottom. Remainder of panel consists of one glass tile utilizing a single panel of 1/4" thick tempered glass. Base is 6". Panel thickness: 3 1/2".

STANDARD PANEL SIZES (Fabric/Glass-Acoustic and Highly Acoustic)

	12" W	18" W	24" W	30" W	36" W	42" W	48" W	54" W	60" W	Side 1 Number of	Side 2 Number of
	12" Fabric Tiles	12" Fabric Tiles	12" Fabric Tiles	12" Fabric Tiles	12" Fabric Tiles	12" Fabric Tiles	12" Fabric Tiles	12" Fabric Tiles	12" Fabric Tiles	12" Fabric Tiles	12" Fabric Tiles
30" H	N/A	N/A	N/A	N/A	N/A	N/A	N/A	N/A	N/A	N/A	N/A
42" H	N/A	N/A	N/A	N/A	N/A	N/A	N/A	N/A	N/A	N/A	N/A
54" H	•	•	•	•	•	•	•	N/A	N/A	N/A	N/A
66" H	•	•	•	•	•	•	•	N/A	N/A	N/A	N/A
84" H	•	•	•	•	•	•	•	N/A	N/A	N/A	N/A

Face Style: Monolithic/Fully Segmented/Glass

Basic Model: P1MFGA - KD1

**Basic Model: PMFGA-
Pass Through**

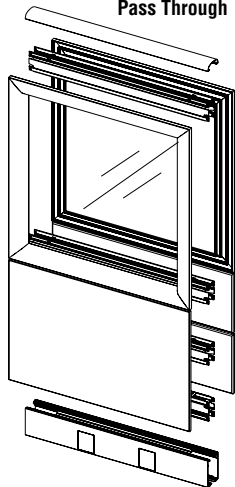

Monolithic/Fully Segmented/Glass panels consist of the following:
24" fabric tile on bottom of side one, two 12" segmented fabric tiles on bottom of side two.
Remainder of panel consists of one glass tile utilizing a single panel of 1/4" thick tempered glass.
Base is 6". Panel thickness: 3 1/2".

STANDARD PANEL SIZES (Fabric/Glass-Acoustic)

	12" W	18" W	24" W	30" W	36" W	42" W	48" W	54" W	60" W	Side 1 Number of	Side 2 Number of
										12" Fabric Tiles	12" Fabric Tiles
30" H	N/A	N/A	N/A	N/A	N/A	N/A	N/A	N/A	N/A	N/A	N/A
42" H	N/A	N/A	N/A	N/A	N/A	N/A	N/A	N/A	N/A	N/A	N/A
54" H	•	•	•	•	•	•	•	N/A	N/A	N/A	2
66" H	•	•	•	•	•	•	•	N/A	N/A	N/A	2
84" H	•	•	•	•	•	•	•	N/A	N/A	N/A	2

Face Style: Glass/Fully Segmented

Basic Model: P1FFGA - KD1

**Basic Model: PFFGA-
Pass Through**

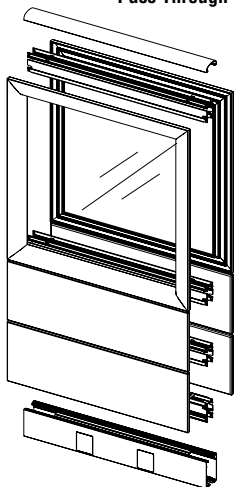

Glass/Fully Segmented panels consist of the following:
Two 12" fabric tile on bottom. Remainder of panel consists of one glass tile utilizing a single panel of 1/4" thick tempered glass.
Base is 6". Panel thickness: 3 1/2".

STANDARD PANEL SIZES (Fabric/Glass-Acoustic)

	12" W	18" W	24" W	30" W	36" W	42" W	48" W	54" W	60" W	Side 1 Number of	Side 2 Number of
										12" Fabric Tiles	12" Fabric Tiles
30" H	N/A	N/A	N/A	N/A	N/A	N/A	N/A	N/A	N/A	N/A	N/A
42" H	N/A	N/A	N/A	N/A	N/A	N/A	N/A	N/A	N/A	N/A	N/A
54" H	•	•	•	•	•	•	•	N/A	N/A	2	2
66" H	•	•	•	•	•	•	•	N/A	N/A	2	2
84" H	•	•	•	•	•	•	•	N/A	N/A	2	2

Glass Panel

Full Glass Panel

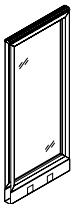
MODEL	W x H	MODEL NUMBER					Approx. Packaged Weight
		Basic Model	Electrical Code	Horizontal Rail	Glass Color	Trim Color	
 <p>Full Glass Panel - 54"H</p> <ul style="list-style-type: none"> • Two horizontal rails • Two aluminum window frames • One pane, 1/4" thick glass • One base/raceway consisting of a raceway pan and two doors • One rounded satin-textured polypropylene top cap with splice plate • Order power separately • Order vertical posts separately • SX Starlight Silver finish is only offered on flat aluminum trim 	12 x 54"	PG1254	<input type="checkbox"/>	<input type="checkbox"/>	<input type="checkbox"/>	<input type="checkbox"/>	23.0#
	18 x 54"	PG1854	<input type="checkbox"/>	<input type="checkbox"/>	<input type="checkbox"/>	<input type="checkbox"/>	32.0#
	24 x 54"	PG2454	<input type="checkbox"/>	<input type="checkbox"/>	<input type="checkbox"/>	<input type="checkbox"/>	42.0#
	30 x 54"	PG3054	<input type="checkbox"/>	<input type="checkbox"/>	<input type="checkbox"/>	<input type="checkbox"/>	51.0#
	36 x 54"	PG3654	<input type="checkbox"/>	<input type="checkbox"/>	<input type="checkbox"/>	<input type="checkbox"/>	60.0#
	42 x 54"	PG4254	<input type="checkbox"/>	<input type="checkbox"/>	<input type="checkbox"/>	<input type="checkbox"/>	69.0#
	48 x 54"	PG4854	<input type="checkbox"/>	<input type="checkbox"/>	<input type="checkbox"/>	<input type="checkbox"/>	79.0#
P1G - KD1 PG - Pass Through							
<p>Full Glass Panel - 66"H</p>	12 x 66"	PG1266	<input type="checkbox"/>	<input type="checkbox"/>	<input type="checkbox"/>	<input type="checkbox"/>	27.0#
	18 x 66"	PG1866	<input type="checkbox"/>	<input type="checkbox"/>	<input type="checkbox"/>	<input type="checkbox"/>	38.0#
	24 x 66"	PG2466	<input type="checkbox"/>	<input type="checkbox"/>	<input type="checkbox"/>	<input type="checkbox"/>	49.0#
	30 x 66"	PG3066	<input type="checkbox"/>	<input type="checkbox"/>	<input type="checkbox"/>	<input type="checkbox"/>	59.0#
	36 x 66"	PG3666	<input type="checkbox"/>	<input type="checkbox"/>	<input type="checkbox"/>	<input type="checkbox"/>	70.0#
	42 x 66"	PG4266	<input type="checkbox"/>	<input type="checkbox"/>	<input type="checkbox"/>	<input type="checkbox"/>	81.0#
	48 x 66"	PG4866	<input type="checkbox"/>	<input type="checkbox"/>	<input type="checkbox"/>	<input type="checkbox"/>	92.0#
P1G - KD1 PG - Pass Through							
<p>Full Glass Panel - 84"H</p>	12 x 84"	PG1284	<input type="checkbox"/>	<input type="checkbox"/>	<input type="checkbox"/>	<input type="checkbox"/>	33.0#
	18 x 84"	PG1884	<input type="checkbox"/>	<input type="checkbox"/>	<input type="checkbox"/>	<input type="checkbox"/>	46.0#
	24 x 84"	PG2484	<input type="checkbox"/>	<input type="checkbox"/>	<input type="checkbox"/>	<input type="checkbox"/>	59.0#
	30 x 84"	PG3084	<input type="checkbox"/>	<input type="checkbox"/>	<input type="checkbox"/>	<input type="checkbox"/>	72.0#
	36 x 84"	PG3684	<input type="checkbox"/>	<input type="checkbox"/>	<input type="checkbox"/>	<input type="checkbox"/>	85.0#
	42 x 84"	PG4284	<input type="checkbox"/>	<input type="checkbox"/>	<input type="checkbox"/>	<input type="checkbox"/>	98.0#
	48 x 84"	PG4884	<input type="checkbox"/>	<input type="checkbox"/>	<input type="checkbox"/>	<input type="checkbox"/>	111.0#
P1G - KD1 PG - Pass Through							

A **B** **C** **D** **E**

HOW TO ORDER

Indicate the following information on order form:

1. Quantity of each item.
2. Model number, including options. See "How To Build a Model Number".
3. Any special service required.

Note: • The indicates that a choice is required.
 • The absence of the indicates that no choice is required.
 • Alpha-numeric characters in place of indicate that no other alternatives are available.

HOW TO BUILD A MODEL NUMBER

- A** Select basic model.
- B** Select electrical code for base raceway.
 - DN** - Domestic, no cutouts
 - D1** - Domestic, 1 side w/cutouts
 - D** - Domestic, 2 sides w/cutouts
- C** Select horizontal rail.
 - E** - Enhanced
 - S** - Standard
- D** Select glass color.
 - BRZ** - Tinted/Bronze
 - GLA** - Clear
 - GLC** - White Laminate
- E** Select trim color.
 Refer to the **Product Color Options** page in this catalog.
 SX Starlight Silver finish is only offered on flat aluminum trim.

Glass/Fabric Panel - Acoustic (3/4" Thick Tiles)

Monolithic/Monolithic/Glass Panel

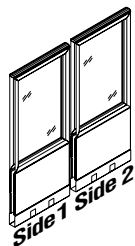

P1MGA - KD1
PMGA - Pass Through

MODEL

W x H

MODEL NUMBER

Basic Model

Electrical Code

Horizontal Rail

Glass Color

Trim Color

Fabric Side 1

Fabric Side 2

Approx. Packaged Weight

Monolithic/Monolithic/Glass Panel - 54"H

- Three horizontal rails
- Two powder-coated aluminum window frames
- Two 24" fabric tiles with mounting hooks
- One pane, 1/4" thick glass
- One base/raceway consisting of a raceway pan and two doors
- One rounded stain-textured polypropylene top cap with splice plate
- Order power separately
- Order vertical posts separately
- Fabric tile is tackable
- SX Starlight Silver finish is only offered on flat aluminum trim

12 x 54"	PMMGA1254	<input type="checkbox"/>	<input type="checkbox"/>	<input type="checkbox"/>	<input type="checkbox"/>	<input type="checkbox"/>	<input type="checkbox"/>	26.0#
18 x 54"	PMMGA1854	<input type="checkbox"/>	<input type="checkbox"/>	<input type="checkbox"/>	<input type="checkbox"/>	<input type="checkbox"/>	<input type="checkbox"/>	36.0#
24 x 54"	PMMGA2454	<input type="checkbox"/>	<input type="checkbox"/>	<input type="checkbox"/>	<input type="checkbox"/>	<input type="checkbox"/>	<input type="checkbox"/>	46.0#
30 x 54"	PMMGA3054	<input type="checkbox"/>	<input type="checkbox"/>	<input type="checkbox"/>	<input type="checkbox"/>	<input type="checkbox"/>	<input type="checkbox"/>	56.0#
36 x 54"	PMMGA3654	<input type="checkbox"/>	<input type="checkbox"/>	<input type="checkbox"/>	<input type="checkbox"/>	<input type="checkbox"/>	<input type="checkbox"/>	66.0#
42 x 54"	PMMGA4254	<input type="checkbox"/>	<input type="checkbox"/>	<input type="checkbox"/>	<input type="checkbox"/>	<input type="checkbox"/>	<input type="checkbox"/>	76.0#
48 x 54"	PMMGA4854	<input type="checkbox"/>	<input type="checkbox"/>	<input type="checkbox"/>	<input type="checkbox"/>	<input type="checkbox"/>	<input type="checkbox"/>	85.0#

Monolithic/Monolithic/Glass Panel - 66"H

12 x 66"	PMMGA1266	<input type="checkbox"/>	<input type="checkbox"/>	<input type="checkbox"/>	<input type="checkbox"/>	<input type="checkbox"/>	<input type="checkbox"/>	30.0#
18 x 66"	PMMGA1866	<input type="checkbox"/>	<input type="checkbox"/>	<input type="checkbox"/>	<input type="checkbox"/>	<input type="checkbox"/>	<input type="checkbox"/>	41.0#
24 x 66"	PMMGA2466	<input type="checkbox"/>	<input type="checkbox"/>	<input type="checkbox"/>	<input type="checkbox"/>	<input type="checkbox"/>	<input type="checkbox"/>	53.0#
30 x 66"	PMMGA3066	<input type="checkbox"/>	<input type="checkbox"/>	<input type="checkbox"/>	<input type="checkbox"/>	<input type="checkbox"/>	<input type="checkbox"/>	64.0#
36 x 66"	PMMGA3666	<input type="checkbox"/>	<input type="checkbox"/>	<input type="checkbox"/>	<input type="checkbox"/>	<input type="checkbox"/>	<input type="checkbox"/>	75.0#
42 x 66"	PMMGA4266	<input type="checkbox"/>	<input type="checkbox"/>	<input type="checkbox"/>	<input type="checkbox"/>	<input type="checkbox"/>	<input type="checkbox"/>	86.0#
48 x 66"	PMMGA4866	<input type="checkbox"/>	<input type="checkbox"/>	<input type="checkbox"/>	<input type="checkbox"/>	<input type="checkbox"/>	<input type="checkbox"/>	98.0#

Monolithic/Monolithic/Glass Panel - 84"H

12 x 84"	PMMGA1284	<input type="checkbox"/>	<input type="checkbox"/>	<input type="checkbox"/>	<input type="checkbox"/>	<input type="checkbox"/>	<input type="checkbox"/>	36.0#
18 x 84"	PMMGA1884	<input type="checkbox"/>	<input type="checkbox"/>	<input type="checkbox"/>	<input type="checkbox"/>	<input type="checkbox"/>	<input type="checkbox"/>	50.0#
24 x 84"	PMMGA2484	<input type="checkbox"/>	<input type="checkbox"/>	<input type="checkbox"/>	<input type="checkbox"/>	<input type="checkbox"/>	<input type="checkbox"/>	63.0#
30 x 84"	PMMGA3084	<input type="checkbox"/>	<input type="checkbox"/>	<input type="checkbox"/>	<input type="checkbox"/>	<input type="checkbox"/>	<input type="checkbox"/>	77.0#
36 x 84"	PMMGA3684	<input type="checkbox"/>	<input type="checkbox"/>	<input type="checkbox"/>	<input type="checkbox"/>	<input type="checkbox"/>	<input type="checkbox"/>	90.0#
42 x 84"	PMMGA4284	<input type="checkbox"/>	<input type="checkbox"/>	<input type="checkbox"/>	<input type="checkbox"/>	<input type="checkbox"/>	<input type="checkbox"/>	104.0#
48 x 84"	PMMGA4884	<input type="checkbox"/>	<input type="checkbox"/>	<input type="checkbox"/>	<input type="checkbox"/>	<input type="checkbox"/>	<input type="checkbox"/>	120.0#

A B C D E F G

HOW TO ORDER

Indicate the following information on order form:

1. Quantity of each item.
2. Model number, including options. See "How To Build a Model Number".
3. Any special service required.

Note: • The indicates that a choice is required.
 • The absence of the indicates that no choice is required.
 • Alpha-numeric characters in place of indicate that no other alternatives are available.

HOW TO BUILD A MODEL NUMBER

- A** Select basic model.
- B** Select electrical code for base raceway.
 DN - Domestic, no cutouts
 D1 - Domestic, 1 side w/cutouts
 D - Domestic, 2 sides w/cutouts
- C** Select horizontal rail.
 E - Enhanced
 S - Standard
- D** Select glass color.
 GLA - Clear
 BRZ - Tinted/Bronze
 GLC - White laminate
- E** Select trim color.
 Refer to the **Product Color Options** page in this catalog.
 SX Starlight Silver finish is only offered on flat aluminum trim.
- F** Select fabric side 1.
- G** Select fabric side 2.

Glass/Fabric Panel - Acoustic (3/4" Thick Tiles)

Monolithic/Fully Segmented/Glass Panel

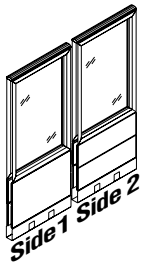
W x H	MODEL NUMBER									Approx. Packaged Weight
	Basic Model	Electrical Code	Horizontal Rail	Number of Raceway Tiles Side 1	Number of Raceway Tiles Side 2	Glass Color	Trim Color	Fabric Side 1	Fabric Side 2	
12 x 54"	PMFGA1254	<input type="checkbox"/>	<input type="checkbox"/>	R0	<input type="checkbox"/>	<input type="checkbox"/>	<input type="checkbox"/>	<input type="checkbox"/>	<input type="checkbox"/>	29.0#
18 x 54"	PMFGA1854	<input type="checkbox"/>	<input type="checkbox"/>	R0	<input type="checkbox"/>	<input type="checkbox"/>	<input type="checkbox"/>	<input type="checkbox"/>	<input type="checkbox"/>	40.0#
24 x 54"	PMFGA2454	<input type="checkbox"/>	<input type="checkbox"/>	R0	<input type="checkbox"/>	<input type="checkbox"/>	<input type="checkbox"/>	<input type="checkbox"/>	<input type="checkbox"/>	52.0#
30 x 54"	PMFGA3054	<input type="checkbox"/>	<input type="checkbox"/>	R0	<input type="checkbox"/>	<input type="checkbox"/>	<input type="checkbox"/>	<input type="checkbox"/>	<input type="checkbox"/>	63.0#
36 x 54"	PMFGA3654	<input type="checkbox"/>	<input type="checkbox"/>	R0	<input type="checkbox"/>	<input type="checkbox"/>	<input type="checkbox"/>	<input type="checkbox"/>	<input type="checkbox"/>	75.0#
42 x 54"	PMFGA4254	<input type="checkbox"/>	<input type="checkbox"/>	R0	<input type="checkbox"/>	<input type="checkbox"/>	<input type="checkbox"/>	<input type="checkbox"/>	<input type="checkbox"/>	87.0#
48 x 54"	PMFGA4854	<input type="checkbox"/>	<input type="checkbox"/>	R0	<input type="checkbox"/>	<input type="checkbox"/>	<input type="checkbox"/>	<input type="checkbox"/>	<input type="checkbox"/>	98.0#
										
P1FGA - KD1 PFGA - Pass Through Monolithic/Fully Segmented/Glass Panel - 54"H <ul style="list-style-type: none"> • Four horizontal rails • Two powder-coated aluminum window frames • One pane, 1/4" thick glass • One 24" fabric tile • Two 12" fabric tiles • One base/raceway consisting of a raceway pan and two doors • One rounded satin-textured polypropylene top cap with splice plate • Order power separately • Order vertical posts separately • Fabric tile is tackable • SX Starlight Silver finish is only offered on flat aluminum trim 										
12 x 66"	PMFGA1266	<input type="checkbox"/>	<input type="checkbox"/>	R0	<input type="checkbox"/>	<input type="checkbox"/>	<input type="checkbox"/>	<input type="checkbox"/>	<input type="checkbox"/>	33.0#
18 x 66"	PMFGA1866	<input type="checkbox"/>	<input type="checkbox"/>	R0	<input type="checkbox"/>	<input type="checkbox"/>	<input type="checkbox"/>	<input type="checkbox"/>	<input type="checkbox"/>	46.0#
24 x 66"	PMFGA2466	<input type="checkbox"/>	<input type="checkbox"/>	R0	<input type="checkbox"/>	<input type="checkbox"/>	<input type="checkbox"/>	<input type="checkbox"/>	<input type="checkbox"/>	60.0#
30 x 66"	PMFGA3066	<input type="checkbox"/>	<input type="checkbox"/>	R0	<input type="checkbox"/>	<input type="checkbox"/>	<input type="checkbox"/>	<input type="checkbox"/>	<input type="checkbox"/>	72.0#
36 x 66"	PMFGA3666	<input type="checkbox"/>	<input type="checkbox"/>	R0	<input type="checkbox"/>	<input type="checkbox"/>	<input type="checkbox"/>	<input type="checkbox"/>	<input type="checkbox"/>	85.0#
42 x 66"	PMFGA4266	<input type="checkbox"/>	<input type="checkbox"/>	R0	<input type="checkbox"/>	<input type="checkbox"/>	<input type="checkbox"/>	<input type="checkbox"/>	<input type="checkbox"/>	98.0#
48 x 66"	PMFGA4866	<input type="checkbox"/>	<input type="checkbox"/>	R0	<input type="checkbox"/>	<input type="checkbox"/>	<input type="checkbox"/>	<input type="checkbox"/>	<input type="checkbox"/>	111.0#
A B C D E F G H I										

HOW TO ORDER

Indicate the following information on order form:

- Quantity of each item.
- Model number, including options. See "How To Build a Model Number".
- Any special service required.

Note: • The indicates that a choice is required.
 • The absence of the indicates that no choice is required.
 • Alpha-numeric characters in place of indicate that no other alternatives are available.

HOW TO BUILD A MODEL NUMBER

- A** Select basic model.
- B** Select electrical code for base raceway.
 DN - Domestic, no cutouts
 D1 - Domestic, 1 side w/cutouts
 D - Domestic, 2 sides w/cutouts
- C** Select horizontal rail.
 E - Enhanced
 S - Standard
- D** Select numbers of raceway tiles side 1
 R0 - Side 1 w/no raceway tile
- E** Select numbers of raceway tiles side 2
 R20 - Side 2 w/no raceway tile
 R21 - Side 2 w/1-12" raceway tile
- F** Select glass color.
 GLA - Clear
 BRZ - Tinted/Bronze
 GLC - White laminate
- G** Select trim color.
 Refer to the **Product Color Options** page in this catalog.
 SX Starlight Silver finish is only offered on flat aluminum trim.
- H** Select fabric side 1.
- I** Select fabric side 2.

INFORMATION

Maximum Raceway Tile Possibilities

Panel Height	Side 1	Side 2
54"H	0	1
66"H	0	1
84"H	0	1

Open Panel

Face Styles

Face Style: Fully Open

Basic Model: P10 - KD1

Basic Model: PO-Pass Through

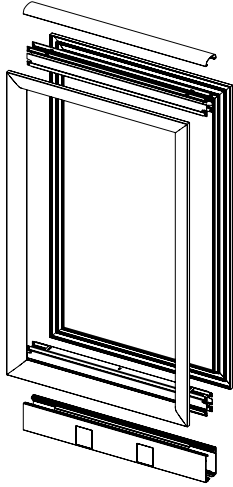

Fully Open panels consist of a full-sized open tile. Base is 6".

STANDARD PANEL SIZES (Open Panels)

	12" W	18" W	24" W	30" W	36" W	42" W	48" W	54" W	60" W	Side 1 Number of	Side 2 Number of
30" H	•	•	•	•	•	•	•	•	•	N/A	N/A
42" H	•	•	•	•	•	•	•	•	•	N/A	N/A
54" H	•	•	•	•	•	•	•	•	•	N/A	N/A
66" H	•	•	•	•	•	•	•	•	•	N/A	N/A
84" H	•	•	•	•	•	•	•	•	•	N/A	N/A

Face Style: Open/Monolithic

Basic Model: P10MMA - KD1

Basic Model: POMMA-
Pass Through

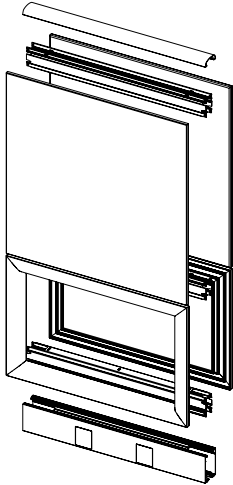

Open/Monolithic panels consist of the following:
24" open tile on bottom. Remainder of panel is a
single fabric tile. Base is 6". Panel thickness: 3 1/2".

STANDARD PANEL SIZES (Open/Fabric-Acoustic)

	12" W	18" W	24" W	30" W	36" W	42" W	48" W	54" W	60" W	Side 1 Number of	Side 2 Number of
30" H	N/A	N/A	N/A	N/A	N/A	N/A	N/A	N/A	N/A	N/A	N/A
42" H	•	•	•	•	•	•	•	•	•	1	1
54" H	•	•	•	•	•	•	•	•	•	N/A	N/A
66" H	•	•	•	•	•	•	•	•	•	N/A	N/A
84" H	•	•	•	•	•	•	•	•	•	N/A	N/A

Face Style: Monolithic/Open Panels

Basic Model: P1MMOA - KD1

Basic Model: PMMOA-Pass Through

Monolithic/Open panels consist of the following:
 24" fabric tile on bottom and an open frame on top.
 Base is 6". Panel thickness: 3 1/2".

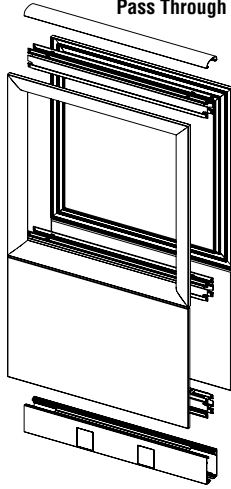

STANDARD PANEL SIZES (Fabric/Open-Acoustic and Highly Acoustic)

	12" W	18" W	24" W	30" W	36" W	42" W	48" W	54" W	60" W	Side 1 Number of	Side 2 Number of
										12" Fabric Tiles	12" Fabric Tiles
30" H	N/A	N/A	N/A	N/A	N/A	N/A	N/A	N/A	N/A	N/A	N/A
42" H	•	•	•	•	•	•	•	•	•	N/A	N/A
54" H	•	•	•	•	•	•	•	•	•	N/A	N/A
66" H	•	•	•	•	•	•	•	•	•	N/A	N/A
84" H	•	•	•	•	•	•	•	•	•	N/A	N/A

Open Panel

Full Open Panel

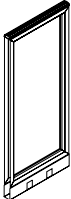
	MODEL	W x H	MODEL NUMBER				Approx. Packaged Weight
			Basic Model	Electrical Code	Horizontal Rail	Trim Color	
	Full Open Panel - 30"H	12 x 30"	PO1230	<input type="checkbox"/>	<input type="checkbox"/>	<input type="checkbox"/>	9.0#
	• Two horizontal rails	18 x 30"	PO1830	<input type="checkbox"/>	<input type="checkbox"/>	<input type="checkbox"/>	13.0#
	• Two powder-coated aluminum window frames	24 x 30"	PO2430	<input type="checkbox"/>	<input type="checkbox"/>	<input type="checkbox"/>	16.0#
	• One base/raceway consisting of a raceway pan and two doors	30 x 30"	PO3030	<input type="checkbox"/>	<input type="checkbox"/>	<input type="checkbox"/>	20.0#
	• One rounded satin-textured polypropylene top cap with splice plate	36 x 30"	PO3630	<input type="checkbox"/>	<input type="checkbox"/>	<input type="checkbox"/>	24.0#
	• Order power separately	42 x 30"	PO4230	<input type="checkbox"/>	<input type="checkbox"/>	<input type="checkbox"/>	27.0#
	• Order vertical posts separately	48 x 30"	PO4830	<input type="checkbox"/>	<input type="checkbox"/>	<input type="checkbox"/>	31.0#
• SX Starlight Silver finish is only offered on flat aluminum trim							
P10 - KD1 PO - Pass Through							
	Full Open Panel - 42"H	12 x 42"	PO1242	<input type="checkbox"/>	<input type="checkbox"/>	<input type="checkbox"/>	10.0#
P10 - KD1		18 x 42"	PO1842	<input type="checkbox"/>	<input type="checkbox"/>	<input type="checkbox"/>	14.0#
PO - Pass Through		24 x 42"	PO2442	<input type="checkbox"/>	<input type="checkbox"/>	<input type="checkbox"/>	18.0#
		30 x 42"	PO3042	<input type="checkbox"/>	<input type="checkbox"/>	<input type="checkbox"/>	21.0#
		36 x 42"	PO3642	<input type="checkbox"/>	<input type="checkbox"/>	<input type="checkbox"/>	25.0#
		42 x 42"	PO4242	<input type="checkbox"/>	<input type="checkbox"/>	<input type="checkbox"/>	28.0#
		48 x 42"	PO4842	<input type="checkbox"/>	<input type="checkbox"/>	<input type="checkbox"/>	32.0#
	Full Open Panel - 54"H	12 x 54"	PO1254	<input type="checkbox"/>	<input type="checkbox"/>	<input type="checkbox"/>	12.0#
P10 - KD1		18 x 54"	PO1854	<input type="checkbox"/>	<input type="checkbox"/>	<input type="checkbox"/>	15.0#
PO - Pass Through		24 x 54"	PO2454	<input type="checkbox"/>	<input type="checkbox"/>	<input type="checkbox"/>	19.0#
		30 x 54"	PO3054	<input type="checkbox"/>	<input type="checkbox"/>	<input type="checkbox"/>	22.0#
		36 x 54"	PO3654	<input type="checkbox"/>	<input type="checkbox"/>	<input type="checkbox"/>	26.0#
		42 x 54"	PO4254	<input type="checkbox"/>	<input type="checkbox"/>	<input type="checkbox"/>	30.0#
		48 x 54"	PO4854	<input type="checkbox"/>	<input type="checkbox"/>	<input type="checkbox"/>	33.0#

A

B

C

D

HOW TO ORDER

Indicate the following information on order form:

- Quantity of each item.
- Model number, including options. See "How To Build a Model Number".
- Any special service required.

Note: • The indicates that a choice is required.

- The absence of the indicates that no choice is required.
- Alpha-numeric characters in place of indicate that no other alternatives are available.

HOW TO BUILD A MODEL NUMBER

A Select basic model.

B Select electrical code for base raceway.

DN - Domestic, no cutouts

D1 - Domestic, 1 side w/cutouts

D - Domestic, 2 sides w/cutouts

C Select horizontal rail.

E - Enhanced

S - Standard

D Select trim color.

Refer to the **Product Color Options** page in this catalog.

SX Starlight Silver finish is only offered on flat aluminum trim.

Open Panel

Full Open Panel

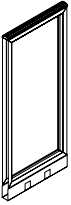
	MODEL	W x H	MODEL NUMBER				Approx. Packaged Weight
			Basic Model	Electrical Code	Horizontal Rail	Trim Color	
 <p>P10 - KD1 PO - Pass Through</p>	Full Open Panel - 66"H	12 x 66"	PO1266	<input type="checkbox"/>	<input type="checkbox"/>	<input type="checkbox"/>	13.0#
	• Two horizontal rails	18 x 66"	PO1866	<input type="checkbox"/>	<input type="checkbox"/>	<input type="checkbox"/>	17.0#
	• Two powder-coated aluminum window frames	24 x 66"	PO2466	<input type="checkbox"/>	<input type="checkbox"/>	<input type="checkbox"/>	20.0#
	• One base/raceway consisting of a raceway pan and two doors	30 x 66"	PO3066	<input type="checkbox"/>	<input type="checkbox"/>	<input type="checkbox"/>	24.0#
	• One rounded satin-textured polypropylene top cap with splice plate	36 x 66"	PO3666	<input type="checkbox"/>	<input type="checkbox"/>	<input type="checkbox"/>	27.0#
	• Order power separately	42 x 66"	PO4266	<input type="checkbox"/>	<input type="checkbox"/>	<input type="checkbox"/>	31.0#
	• Order vertical posts separately	48 x 66"	PO4866	<input type="checkbox"/>	<input type="checkbox"/>	<input type="checkbox"/>	34.0#
	• SX Starlight Silver finish is only offered on flat aluminum trim						
	Full Open Panel - 84"H	12 x 84"	PO1284	<input type="checkbox"/>	<input type="checkbox"/>	<input type="checkbox"/>	15.0#
P10 - KD1		18 x 84"	PO1884	<input type="checkbox"/>	<input type="checkbox"/>	<input type="checkbox"/>	18.0#
PO - Pass Through		24 x 84"	PO2484	<input type="checkbox"/>	<input type="checkbox"/>	<input type="checkbox"/>	22.0#
		30 x 84"	PO3084	<input type="checkbox"/>	<input type="checkbox"/>	<input type="checkbox"/>	25.0#
		36 x 84"	PO3684	<input type="checkbox"/>	<input type="checkbox"/>	<input type="checkbox"/>	29.0#
		42 x 84"	PO4284	<input type="checkbox"/>	<input type="checkbox"/>	<input type="checkbox"/>	33.0#
		48 x 84"	PO4884	<input type="checkbox"/>	<input type="checkbox"/>	<input type="checkbox"/>	36.0#

A **B** **C** **D**

HOW TO ORDER

Indicate the following information on order form:

- Quantity of each item.
- Model number, including options. See "How To Build a Model Number".
- Any special service required.

Note: • The indicates that a choice is required.
• The absence of the indicates that no choice is required.
• Alpha-numeric characters in place of indicate that no other alternatives are available.

HOW TO BUILD A MODEL NUMBER

- A** Select basic model.
- B** Select electrical code for base raceway.
- | | |
|-----------|-------------------------------|
| DN | - Domestic, no cutouts |
| D1 | - Domestic, 1 side w/cutouts |
| D | - Domestic, 2 sides w/cutouts |
- C** Select horizontal rail.
- | | |
|----------|------------|
| E | - Enhanced |
| S | - Standard |
- D** Select trim color.
Refer to the **Product Color Options** page in this catalog.
SX Starlight Silver finish is only offered on flat aluminum trim.

Open/Fabric Panel - Acoustic (3/4" Thick Tiles)

Open/Monolithic/Monolithic Panel

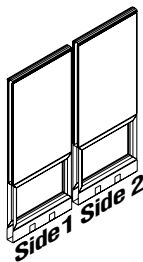
		MODEL NUMBER							Approx. Packaged Weight	
		Basic Model	Electrical Code	Horizontal Rail	Number of Raceway Tiles Side 1	Number of Raceway Tiles Side 2	Trim Color	Fabric Side 1		Fabric Side 2
W x H										
 <p>P10A - KD1 POA - Pass Through Open/Monolithic/Monolithic Panel - 42"H</p> <ul style="list-style-type: none"> • Three horizontal rails • Two aluminum frames • Two full fabric tiles • One base/raceway consisting of a raceway pan and two doors • One rounded satin-textured polypropylene top cap with splice plate • Order power separately • Order vertical posts separately • Fabric tile is tackable • SX Starlight Silver finish is only offered on flat aluminum trim 	12 x 42"	POMMA1242	<input type="checkbox"/>	<input type="checkbox"/>	<input type="checkbox"/>	<input type="checkbox"/>	<input type="checkbox"/>	<input type="checkbox"/>	17.0#	
	18 x 42"	POMMA1842	<input type="checkbox"/>	<input type="checkbox"/>	<input type="checkbox"/>	<input type="checkbox"/>	<input type="checkbox"/>	<input type="checkbox"/>	23.0#	
	24 x 42"	POMMA2442	<input type="checkbox"/>	<input type="checkbox"/>	<input type="checkbox"/>	<input type="checkbox"/>	<input type="checkbox"/>	<input type="checkbox"/>	30.0#	
	30 x 42"	POMMA3042	<input type="checkbox"/>	<input type="checkbox"/>	<input type="checkbox"/>	<input type="checkbox"/>	<input type="checkbox"/>	<input type="checkbox"/>	36.0#	
	36 x 42"	POMMA3642	<input type="checkbox"/>	<input type="checkbox"/>	<input type="checkbox"/>	<input type="checkbox"/>	<input type="checkbox"/>	<input type="checkbox"/>	42.0#	
	42 x 42"	POMMA4242	<input type="checkbox"/>	<input type="checkbox"/>	<input type="checkbox"/>	<input type="checkbox"/>	<input type="checkbox"/>	<input type="checkbox"/>	49.0#	
	48 x 42"	POMMA4842	<input type="checkbox"/>	<input type="checkbox"/>	<input type="checkbox"/>	<input type="checkbox"/>	<input type="checkbox"/>	<input type="checkbox"/>	55.0#	
P10A - KD1 POA - Pass Through Open/Monolithic/Monolithic Panel - 54"H	12 x 54"	POMMA1254	<input type="checkbox"/>	<input type="checkbox"/>			<input type="checkbox"/>	<input type="checkbox"/>	20.0#	
	18 x 54"	POMMA1854	<input type="checkbox"/>	<input type="checkbox"/>			<input type="checkbox"/>	<input type="checkbox"/>	27.0#	
	24 x 54"	POMMA2454	<input type="checkbox"/>	<input type="checkbox"/>			<input type="checkbox"/>	<input type="checkbox"/>	34.0#	
	30 x 54"	POMMA3054	<input type="checkbox"/>	<input type="checkbox"/>			<input type="checkbox"/>	<input type="checkbox"/>	41.0#	
	36 x 54"	POMMA3654	<input type="checkbox"/>	<input type="checkbox"/>			<input type="checkbox"/>	<input type="checkbox"/>	48.0#	
	42 x 54"	POMMA4254	<input type="checkbox"/>	<input type="checkbox"/>			<input type="checkbox"/>	<input type="checkbox"/>	55.0#	
	48 x 54"	POMMA4854	<input type="checkbox"/>	<input type="checkbox"/>			<input type="checkbox"/>	<input type="checkbox"/>	62.0#	
			A	B	C	D	E	F	G	H

HOW TO ORDER

Indicate the following information on order form:

1. Quantity of each item.
2. Model number, including options. See "How To Build a Model Number".
3. Any special service required.

Note: • The indicates that a choice is required.

- The absence of the indicates that no choice is required.
- Alpha-numeric characters in place of indicate that no other alternatives are available.

HOW TO BUILD A MODEL NUMBER

- A** Select basic model.
- B** Select electrical code for base raceway.
- | | |
|----|-------------------------------|
| DN | - Domestic, no cutouts |
| D1 | - Domestic, 1 side w/cutouts |
| D | - Domestic, 2 sides w/cutouts |
- C** Select horizontal rail.
- | | |
|---|------------|
| E | - Enhanced |
| S | - Standard |
- D** Select numbers of raceway tiles side 1
- | | |
|----|-------------------------------|
| R0 | - Side 1 w/no raceway tile |
| R1 | - Side 1 w/1-12" raceway tile |
- E** Select numbers of raceway tiles side 2
- | | |
|-----|-------------------------------|
| R20 | - Side 2 w/no raceway tile |
| R21 | - Side 2 w/1-12" raceway tile |
- F** Select trim color. Refer to the **Product Color Options** page in this catalog. SX Starlight Silver finish is only offered on flat aluminum trim.
- G** Select fabric side 1.
- H** Select fabric side 2.

Open/Fabric Panel - Acoustic (3/4" Thick Tiles)

Open/Monolithic/Monolithic Panel

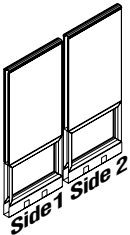

P10A - KD1
POA-Pass Through

P10A - KD1
POA - Pass Through

MODEL	W x H	MODEL NUMBER						Approx. Packaged Weight
		Basic Model	Electrical Code	Horizontal Rail	Trim Color	Fabric Side 1	Fabric Side 2	
Open/Monolithic/Monolithic Panel - 66"H	12 x 66"	POMMA1266	<input type="checkbox"/>	<input type="checkbox"/>	<input type="checkbox"/>	<input type="checkbox"/>	<input type="checkbox"/>	23.0#
	18 x 66"	POMMA1866	<input type="checkbox"/>	<input type="checkbox"/>	<input type="checkbox"/>	<input type="checkbox"/>	<input type="checkbox"/>	31.0#
	24 x 66"	POMMA2466	<input type="checkbox"/>	<input type="checkbox"/>	<input type="checkbox"/>	<input type="checkbox"/>	<input type="checkbox"/>	39.0#
	30 x 66"	POMMA3066	<input type="checkbox"/>	<input type="checkbox"/>	<input type="checkbox"/>	<input type="checkbox"/>	<input type="checkbox"/>	47.0#
	36 x 66"	POMMA3666	<input type="checkbox"/>	<input type="checkbox"/>	<input type="checkbox"/>	<input type="checkbox"/>	<input type="checkbox"/>	54.0#
	42 x 66"	POMMA4266	<input type="checkbox"/>	<input type="checkbox"/>	<input type="checkbox"/>	<input type="checkbox"/>	<input type="checkbox"/>	62.0#
	48 x 66"	POMMA4866	<input type="checkbox"/>	<input type="checkbox"/>	<input type="checkbox"/>	<input type="checkbox"/>	<input type="checkbox"/>	69.0#
Open/Monolithic/Monolithic Panel - 84"H	12 x 84"	POMMA1284	<input type="checkbox"/>	<input type="checkbox"/>	<input type="checkbox"/>	<input type="checkbox"/>	<input type="checkbox"/>	28.0#
	18 x 84"	POMMA1884	<input type="checkbox"/>	<input type="checkbox"/>	<input type="checkbox"/>	<input type="checkbox"/>	<input type="checkbox"/>	37.0#
	24 x 84"	POMMA2484	<input type="checkbox"/>	<input type="checkbox"/>	<input type="checkbox"/>	<input type="checkbox"/>	<input type="checkbox"/>	46.0#
	30 x 84"	POMMA3084	<input type="checkbox"/>	<input type="checkbox"/>	<input type="checkbox"/>	<input type="checkbox"/>	<input type="checkbox"/>	55.0#
	36 x 84"	POMMA3684	<input type="checkbox"/>	<input type="checkbox"/>	<input type="checkbox"/>	<input type="checkbox"/>	<input type="checkbox"/>	63.0#
	42 x 84"	POMMA4284	<input type="checkbox"/>	<input type="checkbox"/>	<input type="checkbox"/>	<input type="checkbox"/>	<input type="checkbox"/>	72.0#
	48 x 84"	POMMA4884	<input type="checkbox"/>	<input type="checkbox"/>	<input type="checkbox"/>	<input type="checkbox"/>	<input type="checkbox"/>	81.0#

A **B** **C** **D** **E** **F**

HOW TO ORDER

Indicate the following information on order form:

- Quantity of each item.
- Model number, including options. See "How To Build a Model Number".
- Any special service required.

- Note:
- The indicates that a choice is required.
 - The absence of the indicates that no choice is required.
 - Alpha-numeric characters in place of indicate that no other alternatives are available.

HOW TO BUILD A MODEL NUMBER

- A** Select basic model.
- B** Select electrical code for base raceway.

DN	- Domestic, no cutouts
D1	- Domestic, 1 side w/cutouts
D	- Domestic, 2 sides w/cutouts
- C** Select horizontal rail.

E	- Enhanced
S	- Standard
- D** Select trim color. Refer to the **Product Color Options** page in this catalog. SX Starlight Silver finish is only offered on flat aluminum trim.
- E** Select fabric side 1.
- F** Select fabric side 2.

Open/Fabric Panel - Acoustic (3/4" Thick Tiles)

Monolithic/Monolithic/Open Panel

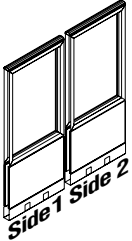
MODEL	W x H	MODEL NUMBER						Approx. Packaged Weight				
		Basic Model	Electrical Code	Horizontal Rail	Trim Color	Fabric Side 1	Fabric Side 2					
 <p>P1MOA - KD1 PMOA - Pass Through</p>	Monolithic/Monolithic/Open Panel - 42"H		12 x 42"	PMMOA1242	<input type="checkbox"/>	<input type="checkbox"/>	<input type="checkbox"/>	<input type="checkbox"/>	<input type="checkbox"/>	<input type="checkbox"/>	19.0#	
			18 x 42"	PMMOA1842	<input type="checkbox"/>	<input type="checkbox"/>	<input type="checkbox"/>	<input type="checkbox"/>	<input type="checkbox"/>	<input type="checkbox"/>	<input type="checkbox"/>	26.0#
			24 x 42"	PMMOA2442	<input type="checkbox"/>	<input type="checkbox"/>	<input type="checkbox"/>	<input type="checkbox"/>	<input type="checkbox"/>	<input type="checkbox"/>	<input type="checkbox"/>	33.0#
			30 x 42"	PMMOA3042	<input type="checkbox"/>	<input type="checkbox"/>	<input type="checkbox"/>	<input type="checkbox"/>	<input type="checkbox"/>	<input type="checkbox"/>	<input type="checkbox"/>	37.0#
			36 x 42"	PMMOA3642	<input type="checkbox"/>	<input type="checkbox"/>	<input type="checkbox"/>	<input type="checkbox"/>	<input type="checkbox"/>	<input type="checkbox"/>	<input type="checkbox"/>	47.0#
			42 x 42"	PMMOA4242	<input type="checkbox"/>	<input type="checkbox"/>	<input type="checkbox"/>	<input type="checkbox"/>	<input type="checkbox"/>	<input type="checkbox"/>	<input type="checkbox"/>	54.0#
			48 x 42"	PMMOA4842	<input type="checkbox"/>	<input type="checkbox"/>	<input type="checkbox"/>	<input type="checkbox"/>	<input type="checkbox"/>	<input type="checkbox"/>	<input type="checkbox"/>	61.0#
<p>P1MOA - KD1 PMOA - Pass Through</p>	Monolithic/Monolithic/Open Panel - 54"H		12 x 54"	PMMOA1254	<input type="checkbox"/>	<input type="checkbox"/>	<input type="checkbox"/>	<input type="checkbox"/>	<input type="checkbox"/>	<input type="checkbox"/>	20.0#	
			18 x 54"	PMMOA1854	<input type="checkbox"/>	<input type="checkbox"/>	<input type="checkbox"/>	<input type="checkbox"/>	<input type="checkbox"/>	<input type="checkbox"/>	<input type="checkbox"/>	27.0#
			24 x 54"	PMMOA2454	<input type="checkbox"/>	<input type="checkbox"/>	<input type="checkbox"/>	<input type="checkbox"/>	<input type="checkbox"/>	<input type="checkbox"/>	<input type="checkbox"/>	34.0#
			30 x 54"	PMMOA3054	<input type="checkbox"/>	<input type="checkbox"/>	<input type="checkbox"/>	<input type="checkbox"/>	<input type="checkbox"/>	<input type="checkbox"/>	<input type="checkbox"/>	41.0#
			36 x 54"	PMMOA3654	<input type="checkbox"/>	<input type="checkbox"/>	<input type="checkbox"/>	<input type="checkbox"/>	<input type="checkbox"/>	<input type="checkbox"/>	<input type="checkbox"/>	48.0#
			42 x 54"	PMMOA4254	<input type="checkbox"/>	<input type="checkbox"/>	<input type="checkbox"/>	<input type="checkbox"/>	<input type="checkbox"/>	<input type="checkbox"/>	<input type="checkbox"/>	55.0#
			48 x 54"	PMMOA4854	<input type="checkbox"/>	<input type="checkbox"/>	<input type="checkbox"/>	<input type="checkbox"/>	<input type="checkbox"/>	<input type="checkbox"/>	<input type="checkbox"/>	62.0#

A B C D E F

HOW TO ORDER

Indicate the following information on order form:

- Quantity of each item.
- Model number, including options. See "How To Build a Model Number".
- Any special service required.

Note: • The indicates that a choice is required.

• The absence of the indicates that no choice is required.

• Alpha-numeric characters in place of indicate that no other alternatives are available.

HOW TO BUILD A MODEL NUMBER

A Select basic model.

B Select electrical code for base raceway.

- DN** - Domestic, no cutouts
- D1** - Domestic, 1 side w/cutouts
- D** - Domestic, 2 sides w/cutouts

C Select horizontal rail.

- E** - Enhanced
- S** - Standard

D Select trim color.

Refer to the **Product Color Options** page in this catalog.

SX Starlight Silver finish is only offered on flat aluminum trim.

E Select fabric side 1.

F Select fabric side 2.

Open/Fabric Panel - Acoustic (3/4" Thick Tiles)

Monolithic/Monolithic/Open Panel

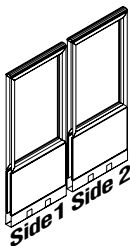

P1MOA - KD1
PMOA - Pass Through

P1MOA - KD1
PMOA - Pass Through

MODEL

W x H

MODEL NUMBER

Basic Model

Electrical Code

Horizontal Rail

Trim Color

Fabric Side 1

Fabric Side 2

Approx. Packaged Weight

Monolithic/Monolithic/Open Panel - 66"H

12 x 66"
18 x 66"
24 x 66"
30 x 66"
36 x 66"
42 x 66"
48 x 66"

PMMOA1266
PMMOA1866
PMMOA2466
PMMOA3066
PMMOA3666
PMMOA4266
PMMOA4866

21.0#
28.0#
36.0#
43.0#
50.0#
57.0#
64.0#

Monolithic/Monolithic/Open Panel - 84"H

12 x 84"
18 x 84"
24 x 84"
30 x 84"
36 x 84"
42 x 84"
48 x 84"

PMMOA1284
PMMOA1884
PMMOA2484
PMMOA3084
PMMOA3684
PMMOA4284
PMMOA4884

23.0#
30.0#
38.0#
44.0#
51.0#
58.0#
65.0#

A **B** **C** **D** **E** **F**

HOW TO ORDER

Indicate the following information on order form:

1. Quantity of each item.
2. Model number, including options. See "How To Build a Model Number".
3. Any special service required.

- Note:
- The indicates that a choice is required.
 - The absence of the indicates that no choice is required.
 - Alpha-numeric characters in place of indicate that no other alternatives are available.

HOW TO BUILD A MODEL NUMBER

- A** Select basic model.
- B** Select electrical code for base raceway.

DN	- Domestic, no cutouts
D1	- Domestic, 1 side w/cutouts
D	- Domestic, 2 sides w/cutouts
- C** Select horizontal rail.

E	- Enhanced
S	- Standard
- D** Select trim color. Refer to the **Product Color Options** page in this catalog. SX Starlight Silver finish is only offered on flat aluminum trim.
- E** Select fabric side 1.
- F** Select fabric side 2.

Fabric Stackable Section - Acoustic (3/4" Tiles)

	MODEL	W x H	MODEL NUMBER						Approx. Packaged Weight	
			Basic Model	Electrical Code	Number of Raceway Tiles Side 1	Number of Raceway Tiles Side 2	Fabric Side 1	Fabric Side 2		
 <p>P1SA - KD1 PSA - Pass Through</p>	Stackable Fabric Section - 12"H	12 x 12"	PSA1212	<input type="checkbox"/>	<input type="checkbox"/>	<input type="checkbox"/>	<input type="checkbox"/>	<input type="checkbox"/>	<input type="checkbox"/>	8.0#
	• One horizontal rail	18 x 12"	PSA1812	<input type="checkbox"/>	<input type="checkbox"/>	<input type="checkbox"/>	<input type="checkbox"/>	<input type="checkbox"/>	<input type="checkbox"/>	10.0#
	• Two full fabric tiles with mounting hooks	24 x 12"	PSA2412	<input type="checkbox"/>	<input type="checkbox"/>	<input type="checkbox"/>	<input type="checkbox"/>	<input type="checkbox"/>	<input type="checkbox"/>	13.0#
	• Use top cap from existing lower panel	30 x 12"	PSA3012	<input type="checkbox"/>	<input type="checkbox"/>	<input type="checkbox"/>	<input type="checkbox"/>	<input type="checkbox"/>	<input type="checkbox"/>	16.0#
	• Order power separately	36 x 12"	PSA3612	<input type="checkbox"/>	<input type="checkbox"/>	<input type="checkbox"/>	<input type="checkbox"/>	<input type="checkbox"/>	<input type="checkbox"/>	19.0#
	• Order stackable vertical posts separately	42 x 12"	PSA4212	<input type="checkbox"/>	<input type="checkbox"/>	<input type="checkbox"/>	<input type="checkbox"/>	<input type="checkbox"/>	<input type="checkbox"/>	22.0#
	• Fabric tile is stackable	48 x 12"	PSA4812	<input type="checkbox"/>	<input type="checkbox"/>	<input type="checkbox"/>	<input type="checkbox"/>	<input type="checkbox"/>	<input type="checkbox"/>	25.0#
		54 x 12"	PSA5412	<input type="checkbox"/>	<input type="checkbox"/>	<input type="checkbox"/>	<input type="checkbox"/>	<input type="checkbox"/>	<input type="checkbox"/>	28.0#
		60 x 12"	PSA6012	<input type="checkbox"/>	<input type="checkbox"/>	<input type="checkbox"/>	<input type="checkbox"/>	<input type="checkbox"/>	<input type="checkbox"/>	31.0#
	<p>P1SA - KD1 PSA - Pass Through</p>	Stackable Fabric Section - 18"H	12 x 18"	PSA1218		R0	R20	<input type="checkbox"/>	<input type="checkbox"/>	9.0#
		18 x 18"	PSA1818		R0	R20	<input type="checkbox"/>	<input type="checkbox"/>	12.0#	
		24 x 18"	PSA2418		R0	R20	<input type="checkbox"/>	<input type="checkbox"/>	16.0#	
		30 x 18"	PSA3018		R0	R20	<input type="checkbox"/>	<input type="checkbox"/>	19.0#	
		36 x 18"	PSA3618		R0	R20	<input type="checkbox"/>	<input type="checkbox"/>	22.0#	
		42 x 18"	PSA4218		R0	R20	<input type="checkbox"/>	<input type="checkbox"/>	25.0#	
		48 x 18"	PSA4818		R0	R20	<input type="checkbox"/>	<input type="checkbox"/>	28.0#	
		54 x 18"	PSA5418		R0	R20	<input type="checkbox"/>	<input type="checkbox"/>	31.0#	
<p>P1SA - KD1 PSA - Pass Through</p>	Stackable Fabric Section - 24"H	12 x 24"	PSA1224		R0	R20	<input type="checkbox"/>	<input type="checkbox"/>	11.0#	
		18 x 24"	PSA1824		R0	R20	<input type="checkbox"/>	<input type="checkbox"/>	14.0#	
		24 x 24"	PSA2424		R0	R20	<input type="checkbox"/>	<input type="checkbox"/>	18.0#	
		30 x 24"	PSA3024		R0	R20	<input type="checkbox"/>	<input type="checkbox"/>	21.0#	
		36 x 24"	PSA3624		R0	R20	<input type="checkbox"/>	<input type="checkbox"/>	25.0#	
		42 x 24"	PSA4224		R0	R20	<input type="checkbox"/>	<input type="checkbox"/>	28.0#	
		48 x 24"	PSA4824		R0	R20	<input type="checkbox"/>	<input type="checkbox"/>	32.0#	
		54 x 24"	PSA5424		R0	R20	<input type="checkbox"/>	<input type="checkbox"/>	35.0#	
	60 x 24"	PSA6024		R0	R20	<input type="checkbox"/>	<input type="checkbox"/>	39.0#		

Ⓐ
Ⓑ
Ⓒ
Ⓓ
Ⓔ
Ⓕ

HOW TO ORDER

Indicate the following information on order form:

- Quantity of each item.
- Model number, including options. See "How To Build a Model Number".
- Any special service required.

Note: • The indicates that a choice is required.

- The absence of the indicates that no choice is required.
- Alpha-numeric characters in place of indicate that no other alternatives are available.

HOW TO BUILD A MODEL NUMBER

- Ⓐ** Select basic model.
- Ⓑ** Select electrical code for base raceway.
D - Domestic, 2 sides w/cutouts
- Ⓒ** Select numbers of raceway tiles side 1
R0 - Side 1 w/no raceway tile
R1 - Side 1 w/1-12" raceway tile
- Ⓓ** Select numbers of raceway tiles side 2
R20 - Side 2 w/no raceway tile
R21 - Side 2 w/1-12" raceway tile
- Ⓔ** Select fabric side 1.
- Ⓕ** Select fabric side 2.

Glass Stackable Section

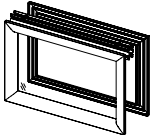
	MODEL	W x H	MODEL NUMBER			Approx. Packaged Weight
			Basic Model	Glass Color	Trim Color	
 <p>P1SG - KD1 PSG - Pass Through</p>	Stackable Glass Section - 12"H	12 x 12"	PSG1212	<input type="checkbox"/> <input type="checkbox"/> <input type="checkbox"/>	<input type="checkbox"/>	7.0#
	• One horizontal rail	18 x 12"	PSG1812	<input type="checkbox"/> <input type="checkbox"/> <input type="checkbox"/>	<input type="checkbox"/>	11.0#
	• Two powder-coated aluminum window frames	24 x 12"	PSG2412	<input type="checkbox"/> <input type="checkbox"/> <input type="checkbox"/>	<input type="checkbox"/>	14.0#
	• One pane, 1/4" thick glass	30 x 12"	PSG3012	<input type="checkbox"/> <input type="checkbox"/> <input type="checkbox"/>	<input type="checkbox"/>	17.0#
	• Use top cap from existing lower panel	36 x 12"	PSG3612	<input type="checkbox"/> <input type="checkbox"/> <input type="checkbox"/>	<input type="checkbox"/>	20.0#
	• Order stackable vertical posts separately	42 x 12"	PSG4212	<input type="checkbox"/> <input type="checkbox"/> <input type="checkbox"/>	<input type="checkbox"/>	23.0#
		48 x 12"	PSG4812	<input type="checkbox"/> <input type="checkbox"/> <input type="checkbox"/>	<input type="checkbox"/>	26.0#
<p>P1SG - KD1 PSG - Pass Through</p>	Stackable Glass Section - 18"H	12 x 18"	PSG1218	<input type="checkbox"/> <input type="checkbox"/> <input type="checkbox"/>	<input type="checkbox"/>	9.0#
		18 x 18"	PSG1818	<input type="checkbox"/> <input type="checkbox"/> <input type="checkbox"/>	<input type="checkbox"/>	13.0#
		24 x 18"	PSG2418	<input type="checkbox"/> <input type="checkbox"/> <input type="checkbox"/>	<input type="checkbox"/>	17.0#
		30 x 18"	PSG3018	<input type="checkbox"/> <input type="checkbox"/> <input type="checkbox"/>	<input type="checkbox"/>	21.0#
		36 x 18"	PSG3618	<input type="checkbox"/> <input type="checkbox"/> <input type="checkbox"/>	<input type="checkbox"/>	25.0#
		42 x 18"	PSG4218	<input type="checkbox"/> <input type="checkbox"/> <input type="checkbox"/>	<input type="checkbox"/>	29.0#
		48 x 18"	PSG4818	<input type="checkbox"/> <input type="checkbox"/> <input type="checkbox"/>	<input type="checkbox"/>	33.0#
<p>P1SG - KD1 PSG - Pass Through</p>	Stackable Glass Section - 24"H	12 x 24"	PSG1224	<input type="checkbox"/> <input type="checkbox"/> <input type="checkbox"/>	<input type="checkbox"/>	14.0#
		18 x 24"	PSG1824	<input type="checkbox"/> <input type="checkbox"/> <input type="checkbox"/>	<input type="checkbox"/>	16.0#
		24 x 24"	PSG2424	<input type="checkbox"/> <input type="checkbox"/> <input type="checkbox"/>	<input type="checkbox"/>	22.0#
		30 x 24"	PSG3024	<input type="checkbox"/> <input type="checkbox"/> <input type="checkbox"/>	<input type="checkbox"/>	25.0#
		36 x 24"	PSG3624	<input type="checkbox"/> <input type="checkbox"/> <input type="checkbox"/>	<input type="checkbox"/>	30.0#
		42 x 24"	PSG4224	<input type="checkbox"/> <input type="checkbox"/> <input type="checkbox"/>	<input type="checkbox"/>	34.0#
		48 x 24"	PSG4824	<input type="checkbox"/> <input type="checkbox"/> <input type="checkbox"/>	<input type="checkbox"/>	39.0#

A **B** **C**

HOW TO ORDER

Indicate the following information on order form:

- Quantity of each item.
- Model number, including options. See "How To Build a Model Number".
- Any special service required.

Note: • The indicates that a choice is required.
• The absence of the indicates that no choice is required.
• Alpha-numeric characters in place of indicate that no other alternatives are available.

HOW TO BUILD A MODEL NUMBER

A Select basic model.

B Select glass color.

GLA - Clear
BRZ - Tinted/Bronze
GLC - White Laminate

C Select trim color.

Refer to the **Product Color Options** page in this catalog.

Open Stackable Section

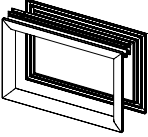
MODEL	W x H	MODEL NUMBER		Approx. Packaged Weight
		Basic Model	Trim Color	
 <p>Stackable Open Section - 12"H</p> <ul style="list-style-type: none"> • One horizontal rail • Two aluminum frames • Use top cap from existing lower panel • Order stackable vertical posts separately 	12 x 12"	PS01212	<input type="checkbox"/>	4.0#
	18 x 12"	PS01812	<input type="checkbox"/>	6.0#
	24 x 12"	PS02412	<input type="checkbox"/>	8.0#
	30 x 12"	PS03012	<input type="checkbox"/>	10.0#
	36 x 12"	PS03612	<input type="checkbox"/>	11.0#
	42 x 12"	PS04212	<input type="checkbox"/>	13.0#
	48 x 12"	PS04812	<input type="checkbox"/>	15.0#
P1SO - KD1 PSO - Pass Through				
<p>Stackable Open Section - 18"H</p>	12 x 18"	PS01218	<input type="checkbox"/>	5.0#
	18 x 18"	PS01818	<input type="checkbox"/>	7.0#
	24 x 18"	PS02418	<input type="checkbox"/>	9.0#
	30 x 18"	PS03018	<input type="checkbox"/>	10.0#
	36 x 18"	PS03618	<input type="checkbox"/>	12.0#
	42 x 18"	PS04218	<input type="checkbox"/>	14.0#
	48 x 18"	PS04818	<input type="checkbox"/>	15.0#
P1SO - KD1 PSO - Pass Through				
<p>Stackable Open Section - 24"H</p>	12 x 24"	PS01224	<input type="checkbox"/>	6.0#
	18 x 24"	PS01824	<input type="checkbox"/>	7.0#
	24 x 24"	PS02424	<input type="checkbox"/>	9.0#
	30 x 24"	PS03024	<input type="checkbox"/>	11.0#
	36 x 24"	PS03624	<input type="checkbox"/>	13.0#
	42 x 24"	PS04224	<input type="checkbox"/>	14.0#
	48 x 24"	PS04824	<input type="checkbox"/>	16.0#
P1SO - KD1 PSO - Pass Through				

A

B

HOW TO ORDER

Indicate the following information on order form:

1. Quantity of each item.
2. Model number, including options. See "How To Build a Model Number".
3. Any special service required.

Note: • The indicates that a choice is required.

- The absence of the indicates that no choice is required.
- Alpha-numeric characters in place of indicate that no other alternatives are available.

HOW TO BUILD A MODEL NUMBER

A Select basic model.

B Select trim color.
Refer to the **Product Color Options** page in this catalog.

HOW TO ORDER

Indicate the following information on order form:

1. Quantity of each item.
2. Model number, including options. See "How To Build a Model Number".
3. Any special service required.

Note:

- The indicates that a choice is required.
- The absence of the indicates that no choice is required.
- Alpha-numeric characters in place of indicate that no other alternatives are available.

Doors

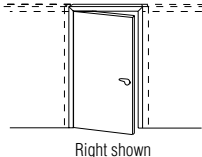
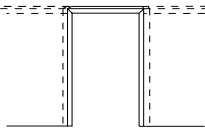
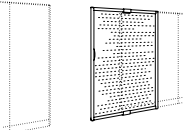
MODEL	Panel Width	W x H	MODEL NUMBER				Approx. Packaged Weight	
			Basic Model	Trim Color	Surface Finish	Frame Color		
 <p>PDR</p> <p>Door</p> <ul style="list-style-type: none"> Provides visual and acoustical privacy For use in conjunction with 84" panels Laminate surface on hollow core door Locking and non-locking options Lever handle to meet ADA guidelines Door hand swing is determined by standing on the side of door that swings toward the user when opening (handle to right is a right hand door) SX Starlight Silver finish is only offered on flat aluminum trim 	36" Right handed Locking	30 x 80"	PDRR36/L	<input type="checkbox"/>	<input type="checkbox"/>		40.0#	
	36" Right handed Non-Locking	30 x 80"	PDRR36/N	<input type="checkbox"/>	<input type="checkbox"/>		40.0#	
	36" Left handed Locking	30 x 80"	PDRL36/L	<input type="checkbox"/>	<input type="checkbox"/>		40.0#	
	36" Left handed Non-Locking	30 x 80"	PDRL36/N	<input type="checkbox"/>	<input type="checkbox"/>		40.0#	
	42" Right handed Locking	36 x 80"	PDRR42/L	<input type="checkbox"/>	<input type="checkbox"/>		43.0#	
	42" Right handed Non-Locking	36 x 80"	PDRR42/N	<input type="checkbox"/>	<input type="checkbox"/>		43.0#	
	42" Left handed Locking	36 x 80"	PDRL42/L	<input type="checkbox"/>	<input type="checkbox"/>		43.0#	
	42" Left handed Non-Locking	36 x 80"	PDRL42/N	<input type="checkbox"/>	<input type="checkbox"/>		43.0#	
 <p>PCOT</p> <p>Door Pass-Through</p> <ul style="list-style-type: none"> Trim SX Starlight Silver finish is only offered on flat aluminum trim 	36" x 84" H	30 x 80"	PCOT36	<input type="checkbox"/>			1.0#	
	42" x 84" H	36 x 80"	PCOT42	<input type="checkbox"/>			2.0#	
 <p>RSD</p> <p>Door Sliding</p> <ul style="list-style-type: none"> Will cover a 42" opening Designed to fit any panel 66" high & over Aluminum frame w/clear poly insert 		48 x 66"	RSD4266FHC/CP/WW			<input type="checkbox"/>	24.0#	

A **B** **C** **D**

HOW TO ORDER

Indicate the following information on order form:



- Quantity of each item.
- Model number, including options. See "How To Build a Model Number".
- Any special service required.

Note: • The indicates that a choice is required.

- The absence of the indicates that no choice is required.
- Alpha-numeric characters in place of indicate that no other alternatives are available.

HOW TO BUILD A MODEL NUMBER

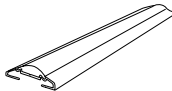
- A** Select basic model.
- B** Select trim color.
Refer to the **Product Color Options** page in this catalog.
SX Starlight Silver finish is only offered on flat aluminum trim.
- C** Select surface finish.
Refer to the **Product Color Options** page in this catalog.
- D** Select frame color.
Refer to the **Product Color Options** page in this catalog.

				MODEL NUMBER				Approx. Packaged Weight
MODEL	Panel Width	W x H	Basic Model	Trim Color	Surface Finish	Frame Color		
 HRDPT	Door Threshold <ul style="list-style-type: none"> Provides extra stability for attaching panels in a continuous run Available in door widths only Extruded aluminum door threshold with rubber seal strip Attaches to bottom of door frame SX Starlight Silver finish is only offered on flat aluminum trim 	36"	PDRTH36	<input type="checkbox"/>			1.0#	
		42"	PDRTH42	<input type="checkbox"/>			2.0#	
 HRDPT	Coat Hooks/Picture Hanger <ul style="list-style-type: none"> Attaches under the top cap of the panel to support coat hangers Translucent plastic only Lock device holds hook securely to panel Can also be used to hang a picture (30# weight limit) 		PCH.CL				1.0#	

A
B
C
D

HOW TO ORDER

Indicate the following information on order form:

- Quantity of each item.
- Model number, including options. See "How To Build a Model Number".
- Any special service required.

Note:

- The indicates that a choice is required.
- The absence of the indicates that no choice is required.
- Alpha-numeric characters in place of indicate that no other alternatives are available.

HOW TO BUILD A MODEL NUMBER

- A** Select basic model.
- B** Select trim color.
Refer to the **Product Color Options** page in this catalog.
SX Starlight Silver finish is only offered on flat aluminum trim.
- C** Select surface finish.
Refer to the **Product Color Options** page in this catalog.
- D** Select frame color.
Refer to the **Product Color Options** page in this catalog.

Preconfigured Intersection Conditions

90° 2-Way and End-of-Run

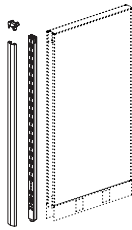
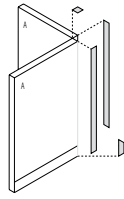
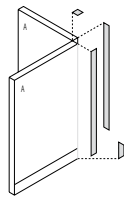
MODEL	H	MODEL NUMBER				Approx. Packaged Weight
		Basic Model	Trim Color	Fabric Color	Assembly	
 <p>End-of-Run Condition</p> <ul style="list-style-type: none"> • Upholstered: trim colored • End-of-run trim • Top cap • Full-height post • SX Starlight Silver finish is only offered on flat aluminum trim 	30"	PEP30	<input type="checkbox"/>			5.0#
	36"	PEP36	<input type="checkbox"/>			5.0#
	42"	PEP42	<input type="checkbox"/>			7.0#
	48"	PEP48	<input type="checkbox"/>			7.0#
	54"	PEP54	<input type="checkbox"/>			9.0#
	60"	PEP60	<input type="checkbox"/>			9.0#
	66"	PEP66	<input type="checkbox"/>			11.0#
	72"	PEP72	<input type="checkbox"/>			11.0#
	78"	PEP78	<input type="checkbox"/>			12.0#
	84"	PEP84	<input type="checkbox"/>			13.0#
P1TN - KD1 PTN - Pass Through						
 <p>90° 2-Way "L" Corner, Both Panels Same Height</p> <ul style="list-style-type: none"> • Upholstered: trim colored • 90° top cap • 90° corner base trim • Two pieces of universal trim • Two half-posts • Connecting hardware • SX Starlight Silver finish is only offered on flat aluminum trim 	30"	PCP9030	<input type="checkbox"/>		<input type="checkbox"/>	7.0#
	36"	PCP9036	<input type="checkbox"/>		<input type="checkbox"/>	7.0#
	42"	PCP9042	<input type="checkbox"/>		<input type="checkbox"/>	10.0#
	48"	PCP9048	<input type="checkbox"/>		<input type="checkbox"/>	10.0#
	54"	PCP9054	<input type="checkbox"/>		<input type="checkbox"/>	13.0#
	60"	PCP9060	<input type="checkbox"/>		<input type="checkbox"/>	13.0#
	66"	PCP9066	<input type="checkbox"/>		<input type="checkbox"/>	16.0#
	72"	PCP9072	<input type="checkbox"/>		<input type="checkbox"/>	16.0#
	78"	PCP9078	<input type="checkbox"/>		<input type="checkbox"/>	18.0#
	84"	PCP9084	<input type="checkbox"/>		<input type="checkbox"/>	20.0#
P1TN - KD1 PTN - Pass Through						
 <p>90° 2-Way "L" Corner, Both Panels Same Height</p> <ul style="list-style-type: none"> • Upholstered • 90° top cap • 90° corner base trim • Two pieces of universal trim • Two half-posts • Connecting hardware • SX Starlight Silver finish is only offered on flat aluminum trim 	30"	PCPF9030	<input type="checkbox"/>	<input type="checkbox"/>	<input type="checkbox"/>	7.0#
	36"	PCPF9036	<input type="checkbox"/>	<input type="checkbox"/>	<input type="checkbox"/>	7.0#
	42"	PCPF9042	<input type="checkbox"/>	<input type="checkbox"/>	<input type="checkbox"/>	10.0#
	48"	PCPF9048	<input type="checkbox"/>	<input type="checkbox"/>	<input type="checkbox"/>	10.0#
	54"	PCPF9054	<input type="checkbox"/>	<input type="checkbox"/>	<input type="checkbox"/>	13.0#
	60"	PCPF9060	<input type="checkbox"/>	<input type="checkbox"/>	<input type="checkbox"/>	13.0#
	66"	PCPF9066	<input type="checkbox"/>	<input type="checkbox"/>	<input type="checkbox"/>	16.0#
	72"	PCPF9072	<input type="checkbox"/>	<input type="checkbox"/>	<input type="checkbox"/>	16.0#
	78"	PCPF9078	<input type="checkbox"/>	<input type="checkbox"/>	<input type="checkbox"/>	18.0#
	84"	PCPF9084	<input type="checkbox"/>	<input type="checkbox"/>	<input type="checkbox"/>	20.0#
P1TF - KD1 PTNF - Pass Through						

A **B** **C** **D**

HOW TO ORDER

Indicate the following information on order form:

1. Quantity of each item.
2. Model number, including options. See "How To Build a Model Number".
3. Any special service required.

Note: • The indicates that a choice is required.

- The absence of the indicates that no choice is required.
- Alpha-numeric characters in place of indicate that no other alternatives are available.

HOW TO BUILD A MODEL NUMBER

- A** Select basic model.
- B** Select trim color.
Refer to the **Product Color Options** page in this catalog.
SX Starlight Silver finish is only offered on flat aluminum trim.
- C** Select fabric color.
- D** Select assembly.

F	- Fully Assembled
U	- Unassembled

Preconfigured Intersection Conditions

90° 2-Way

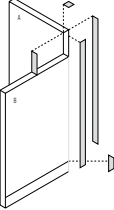
	MODEL	A	B	A-B	MODEL NUMBER		Approx. Packaged Weight
					Basic Model	Trim Color	
 <p>P1TN - KD1 PTN - Pass Through</p>	90° 2-Way "L" Corner, Two Different Heights	36"	30"	6"	PCPV903036	<input type="checkbox"/>	9.0#
		42"	30"	12"	PCPV903042	<input type="checkbox"/>	9.0#
	<ul style="list-style-type: none"> • Unupholstered: trim colored • 1-way cap • 90° corner base trim • Two pieces of universal trim • One piece of universal height change trim • One half-post (height A) • One half-post (height B) • Connecting hardware • SX Starlight Silver finish is only offered on flat aluminum trim 	48"	30"	18"	PCPV903048	<input type="checkbox"/>	9.0#
		54"	30"	24"	PCPV903054	<input type="checkbox"/>	11.0#
		60"	30"	30"	PCPV903060	<input type="checkbox"/>	13.0#
		66"	30"	36"	PCPV903066	<input type="checkbox"/>	13.0#
		72"	30"	42"	PCPV903072	<input type="checkbox"/>	13.0#
		78"	30"	48"	PCPV903078	<input type="checkbox"/>	13.0#
		84"	30"	54"	PCPV903084	<input type="checkbox"/>	16.0#
		42"	36"	6"	PCPV903642	<input type="checkbox"/>	16.0#
		48"	36"	12"	PCPV903648	<input type="checkbox"/>	16.0#
		54"	36"	18"	PCPV903654	<input type="checkbox"/>	16.0#
		60"	36"	24"	PCPV903660	<input type="checkbox"/>	16.0#
		66"	36"	30"	PCPV903666	<input type="checkbox"/>	16.0#
		72"	36"	36"	PCPV903672	<input type="checkbox"/>	16.0#
		78"	36"	42"	PCPV903678	<input type="checkbox"/>	16.0#
		84"	36"	48"	PCPV903684	<input type="checkbox"/>	16.0#
		48"	42"	6"	PCPV904248	<input type="checkbox"/>	12.0#
		54"	42"	12"	PCPV904254	<input type="checkbox"/>	12.0#
		60"	42"	18"	PCPV904260	<input type="checkbox"/>	14.0#
		66"	42"	24"	PCPV904266	<input type="checkbox"/>	14.0#
		72"	42"	30"	PCPV904272	<input type="checkbox"/>	14.0#
		78"	42"	36"	PCPV904278	<input type="checkbox"/>	14.0#
		84"	42"	42"	PCPV904284	<input type="checkbox"/>	17.0#
		54"	48"	6"	PCPV904854	<input type="checkbox"/>	17.0#
		60"	48"	12"	PCPV904860	<input type="checkbox"/>	17.0#
		66"	48"	18"	PCPV904866	<input type="checkbox"/>	17.0#
		72"	48"	24"	PCPV904872	<input type="checkbox"/>	17.0#
		78"	48"	30"	PCPV904878	<input type="checkbox"/>	17.0#
		84"	48"	36"	PCPV904884	<input type="checkbox"/>	17.0#

A

B

HOW TO ORDER

Indicate the following information on order form:

1. Quantity of each item.
2. Model number, including options. See "How To Build a Model Number".
3. Any special service required.

Note: • The indicates that a choice is required.

- The absence of the indicates that no choice is required.
- Alpha-numeric characters in place of indicate that no other alternatives are available.

HOW TO BUILD A MODEL NUMBER

A Select basic model.

B Select trim color.

Refer to the **Product Color Options** page in this catalog.
SX Starlight Silver finish is only offered on flat aluminum trim.

Preconfigured Intersection Conditions

90° 2-Way

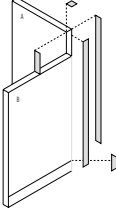
MODEL	A B A-B	MODEL NUMBER		Approx. Packaged Weight
		Basic Model	Trim Color	
 <p>P1TN - KD1 PTN - Pass Through</p> <p>90° 2-Way "L" Corner, Two Different Heights</p> <ul style="list-style-type: none"> • Upholstered: trim colored • 1-way cap • 90° corner base trim • Two pieces of universal trim • One piece of universal height change trim • One half-post (height A) • One half-post (height B) • Connecting hardware • SX Starlight Silver finish is only offered on flat aluminum trim 	60" 54" 6"	PCPV905460	<input type="checkbox"/>	15.0#
	66" 54" 12"	PCPV905466	<input type="checkbox"/>	15.0#
	72" 54" 18"	PCPV905472	<input type="checkbox"/>	15.0#
	78" 54" 24"	PCPV905478	<input type="checkbox"/>	15.0#
	84" 54" 30"	PCPV905484	<input type="checkbox"/>	18.0#
	66" 60" 6"	PCPV906066	<input type="checkbox"/>	18.0#
	72" 60" 12"	PCPV906072	<input type="checkbox"/>	18.0#
	78" 60" 18"	PCPV906078	<input type="checkbox"/>	18.0#
	84" 60" 24"	PCPV906084	<input type="checkbox"/>	18.0#
	72" 66" 6"	PCPV906672	<input type="checkbox"/>	18.0#
	78" 66" 12"	PCPV906678	<input type="checkbox"/>	18.0#
	84" 66" 18"	PCPV906684	<input type="checkbox"/>	19.0#
	78" 72" 12"	PCPV907278	<input type="checkbox"/>	19.0#
	84" 72" 12"	PCPV907284	<input type="checkbox"/>	19.0#
	84" 78" 6"	PCPV907884	<input type="checkbox"/>	19.0#

A

B

HOW TO ORDER

Indicate the following information on order form:

1. Quantity of each item.
2. Model number, including options. See "How To Build a Model Number".
3. Any special service required.

Note: • The indicates that a choice is required.

- The absence of the indicates that no choice is required.
- Alpha-numeric characters in place of indicate that no other alternatives are available.

HOW TO BUILD A MODEL NUMBER

A Select basic model.

B Select trim color.

Refer to the **Product Color Options** page in this catalog.
SX Starlight Silver finish is only offered on flat aluminum trim.

Preconfigured Intersection Conditions

90° 2-Way

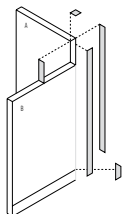

P1TF - KD1
PTNF - Pass Through

MODEL

A B A-B

MODEL NUMBER

Basic Model

Trim Color

Fabric Color

Approx. Packaged Weight

90° 2-Way "L" Corner, Two Different Heights

- Upholstered
- 1-way cap
- 90° corner base trim
- Two fabric-wrapped pieces of universal trim
- One fabric-wrapped piece of universal height change trim
- One half-post (height A)
- One half-post (height B)
- Connecting hardware
- SX Starlight Silver finish is only offered on flat aluminum trim

MODEL	A B A-B	Basic Model	Trim Color	Fabric Color	Approx. Packaged Weight
	36" 30" 6"	PCPVF903036	<input type="checkbox"/>	<input type="checkbox"/> <input type="checkbox"/> <input type="checkbox"/> <input type="checkbox"/>	9.0#
	42" 30" 12"	PCPVF903042	<input type="checkbox"/>	<input type="checkbox"/> <input type="checkbox"/> <input type="checkbox"/> <input type="checkbox"/>	9.0#
	48" 30" 18"	PCPVF903048	<input type="checkbox"/>	<input type="checkbox"/> <input type="checkbox"/> <input type="checkbox"/> <input type="checkbox"/>	9.0#
	54" 30" 24"	PCPVF903054	<input type="checkbox"/>	<input type="checkbox"/> <input type="checkbox"/> <input type="checkbox"/> <input type="checkbox"/>	11.0#
	60" 30" 30"	PCPVF903060	<input type="checkbox"/>	<input type="checkbox"/> <input type="checkbox"/> <input type="checkbox"/> <input type="checkbox"/>	11.0#
	66" 30" 36"	PCPVF903066	<input type="checkbox"/>	<input type="checkbox"/> <input type="checkbox"/> <input type="checkbox"/> <input type="checkbox"/>	13.0#
	72" 30" 42"	PCPVF903072	<input type="checkbox"/>	<input type="checkbox"/> <input type="checkbox"/> <input type="checkbox"/> <input type="checkbox"/>	13.0#
	78" 30" 48"	PCPVF903078	<input type="checkbox"/>	<input type="checkbox"/> <input type="checkbox"/> <input type="checkbox"/> <input type="checkbox"/>	13.0#
	84" 30" 54"	PCPVF903084	<input type="checkbox"/>	<input type="checkbox"/> <input type="checkbox"/> <input type="checkbox"/> <input type="checkbox"/>	16.0#
	42" 36" 6"	PCPVF903642	<input type="checkbox"/>	<input type="checkbox"/> <input type="checkbox"/> <input type="checkbox"/> <input type="checkbox"/>	16.0#
	48" 36" 12"	PCPVF903648	<input type="checkbox"/>	<input type="checkbox"/> <input type="checkbox"/> <input type="checkbox"/> <input type="checkbox"/>	16.0#
	54" 36" 18"	PCPVF903654	<input type="checkbox"/>	<input type="checkbox"/> <input type="checkbox"/> <input type="checkbox"/> <input type="checkbox"/>	16.0#
	60" 36" 24"	PCPVF903660	<input type="checkbox"/>	<input type="checkbox"/> <input type="checkbox"/> <input type="checkbox"/> <input type="checkbox"/>	16.0#
	66" 36" 30"	PCPVF903666	<input type="checkbox"/>	<input type="checkbox"/> <input type="checkbox"/> <input type="checkbox"/> <input type="checkbox"/>	16.0#
	72" 36" 36"	PCPVF903672	<input type="checkbox"/>	<input type="checkbox"/> <input type="checkbox"/> <input type="checkbox"/> <input type="checkbox"/>	16.0#
	78" 36" 42"	PCPVF903678	<input type="checkbox"/>	<input type="checkbox"/> <input type="checkbox"/> <input type="checkbox"/> <input type="checkbox"/>	16.0#
	84" 36" 48"	PCPVF903684	<input type="checkbox"/>	<input type="checkbox"/> <input type="checkbox"/> <input type="checkbox"/> <input type="checkbox"/>	16.0#
	48" 42" 6"	PCPVF904248	<input type="checkbox"/>	<input type="checkbox"/> <input type="checkbox"/> <input type="checkbox"/> <input type="checkbox"/>	16.0#
	54" 42" 12"	PCPVF904254	<input type="checkbox"/>	<input type="checkbox"/> <input type="checkbox"/> <input type="checkbox"/> <input type="checkbox"/>	12.0#
	60" 42" 18"	PCPVF904260	<input type="checkbox"/>	<input type="checkbox"/> <input type="checkbox"/> <input type="checkbox"/> <input type="checkbox"/>	12.0#
	66" 42" 24"	PCPVF904266	<input type="checkbox"/>	<input type="checkbox"/> <input type="checkbox"/> <input type="checkbox"/> <input type="checkbox"/>	14.0#
	72" 42" 30"	PCPVF904272	<input type="checkbox"/>	<input type="checkbox"/> <input type="checkbox"/> <input type="checkbox"/> <input type="checkbox"/>	14.0#
	78" 42" 36"	PCPVF904278	<input type="checkbox"/>	<input type="checkbox"/> <input type="checkbox"/> <input type="checkbox"/> <input type="checkbox"/>	14.0#
	84" 42" 42"	PCPVF904284	<input type="checkbox"/>	<input type="checkbox"/> <input type="checkbox"/> <input type="checkbox"/> <input type="checkbox"/>	17.0#
	54" 48" 6"	PCPVF904854	<input type="checkbox"/>	<input type="checkbox"/> <input type="checkbox"/> <input type="checkbox"/> <input type="checkbox"/>	17.0#
	60" 48" 12"	PCPVF904860	<input type="checkbox"/>	<input type="checkbox"/> <input type="checkbox"/> <input type="checkbox"/> <input type="checkbox"/>	17.0#
	66" 48" 18"	PCPVF904866	<input type="checkbox"/>	<input type="checkbox"/> <input type="checkbox"/> <input type="checkbox"/> <input type="checkbox"/>	17.0#
	72" 48" 24"	PCPVF904872	<input type="checkbox"/>	<input type="checkbox"/> <input type="checkbox"/> <input type="checkbox"/> <input type="checkbox"/>	17.0#
	78" 48" 30"	PCPVF904878	<input type="checkbox"/>	<input type="checkbox"/> <input type="checkbox"/> <input type="checkbox"/> <input type="checkbox"/>	17.0#
	84" 48" 36"	PCPVF904884	<input type="checkbox"/>	<input type="checkbox"/> <input type="checkbox"/> <input type="checkbox"/> <input type="checkbox"/>	17.0#

A **B** **C**

HOW TO ORDER

Indicate the following information on order form:

1. Quantity of each item.
2. Model number, including options. See "How To Build a Model Number".
3. Any special service required.

Note: • The indicates that a choice is required.
 • The absence of the indicates that no choice is required.
 • Alpha-numeric characters in place of indicate that no other alternatives are available.

HOW TO BUILD A MODEL NUMBER

- A** Select basic model.
- B** Select trim color.
Refer to the **Product Color Options** page in this catalog.
SX Starlight Silver finish is only offered on flat aluminum trim.
- C** Select fabric color.

Preconfigured Intersection Conditions

90° 2-Way

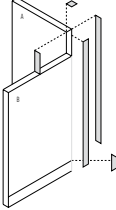
MODEL	A B A-B	MODEL NUMBER			Approx. Packaged Weight
		Basic Model	Trim Color	Fabric Color	
 <p>P1TF - KD1 PTNF - Pass Through</p> <p>90° 2-Way "L" Corner, Two Different Heights</p> <ul style="list-style-type: none"> • Upholstered • 1-way cap • 90° corner base trim • Two fabric-wrapped pieces of universal trim • One fabric-wrapped piece of universal height change trim • One half-post (height A) • One half-post (height B) • Connecting hardware • SX Starlight Silver finish is only offered on flat aluminum trim 	60" 54" 6"	PCPVF905460	<input type="checkbox"/>	<input type="checkbox"/> <input type="checkbox"/> <input type="checkbox"/> <input type="checkbox"/>	15.0#
	66" 54" 12"	PCPVF905466	<input type="checkbox"/>	<input type="checkbox"/> <input type="checkbox"/> <input type="checkbox"/> <input type="checkbox"/>	15.0#
	72" 54" 18"	PCPVF905472	<input type="checkbox"/>	<input type="checkbox"/> <input type="checkbox"/> <input type="checkbox"/> <input type="checkbox"/>	15.0#
	78" 54" 24"	PCPVF905478	<input type="checkbox"/>	<input type="checkbox"/> <input type="checkbox"/> <input type="checkbox"/> <input type="checkbox"/>	15.0#
	84" 54" 30"	PCPVF905484	<input type="checkbox"/>	<input type="checkbox"/> <input type="checkbox"/> <input type="checkbox"/> <input type="checkbox"/>	18.0#
	66" 60" 36"	PCPVF906066	<input type="checkbox"/>	<input type="checkbox"/> <input type="checkbox"/> <input type="checkbox"/> <input type="checkbox"/>	18.0#
	72" 60" 12"	PCPVF906072	<input type="checkbox"/>	<input type="checkbox"/> <input type="checkbox"/> <input type="checkbox"/> <input type="checkbox"/>	18.0#
	78" 60" 18"	PCPVF906078	<input type="checkbox"/>	<input type="checkbox"/> <input type="checkbox"/> <input type="checkbox"/> <input type="checkbox"/>	18.0#
	84" 60" 24"	PCPVF906084	<input type="checkbox"/>	<input type="checkbox"/> <input type="checkbox"/> <input type="checkbox"/> <input type="checkbox"/>	18.0#
	72" 66" 6"	PCPVF906672	<input type="checkbox"/>	<input type="checkbox"/> <input type="checkbox"/> <input type="checkbox"/> <input type="checkbox"/>	19.0#
	78" 66" 12"	PCPVF906678	<input type="checkbox"/>	<input type="checkbox"/> <input type="checkbox"/> <input type="checkbox"/> <input type="checkbox"/>	19.0#
	84" 66" 18"	PCPVF906684	<input type="checkbox"/>	<input type="checkbox"/> <input type="checkbox"/> <input type="checkbox"/> <input type="checkbox"/>	19.0#
	78" 72" 6"	PCPVF907278	<input type="checkbox"/>	<input type="checkbox"/> <input type="checkbox"/> <input type="checkbox"/> <input type="checkbox"/>	19.0#
	84" 72" 12"	PCPVF907284	<input type="checkbox"/>	<input type="checkbox"/> <input type="checkbox"/> <input type="checkbox"/> <input type="checkbox"/>	19.0#
	84" 78" 6"	PCPVF907884	<input type="checkbox"/>	<input type="checkbox"/> <input type="checkbox"/> <input type="checkbox"/> <input type="checkbox"/>	19.0#

A

B

C

HOW TO ORDER

Indicate the following information on order form:

1. Quantity of each item.
2. Model number, including options. See "How To Build a Model Number".
3. Any special service required.

Note: • The indicates that a choice is required.

- The absence of the indicates that no choice is required.
- Alpha-numeric characters in place of indicate that no other alternatives are available.

HOW TO BUILD A MODEL NUMBER

A Select basic model.

B Select trim color.
Refer to the **Product Color Options** page in this catalog.
SX Starlight Silver finish is only offered on flat aluminum trim.

C Select fabric color.

Preconfigured Intersection Conditions

Off-Module Post

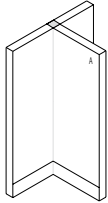

PTN - Pass Through

MODEL

Off-Module Post

- Unupholstered: trim colored
- Off-module top trim end cap
- Off-module half-post
- See specifications for applications
- SX Starlight Silver finish is only offered on flat aluminum trim

MODEL	H	MODEL NUMBER		Approx. Packaged Weight
		Basic Model	Trim Color	
	30"	POMP30	<input type="checkbox"/>	3.0#
	36"	POMP36	<input type="checkbox"/>	3.0#
	42"	POMP42	<input type="checkbox"/>	4.0#
	48"	POMP48	<input type="checkbox"/>	4.0#
	54"	POMP54	<input type="checkbox"/>	5.0#
	60"	POMP60	<input type="checkbox"/>	5.0#
	66"	POMP66	<input type="checkbox"/>	6.0#
	72"	POMP72	<input type="checkbox"/>	6.0#
	78"	POMP78	<input type="checkbox"/>	6.0#
	84"	POMP84	<input type="checkbox"/>	7.0#

A

B

HOW TO ORDER

Indicate the following information on order form:

1. Quantity of each item.
2. Model number, including options. See "How To Build a Model Number".
3. Any special service required.

Note: • The indicates that a choice is required.

- The absence of the indicates that no choice is required.
- Alpha-numeric characters in place of indicate that no other alternatives are available.

HOW TO BUILD A MODEL NUMBER

A Select basic model.

B Select trim color.

Refer to the **Product Color Options** page in this catalog.

SX Starlight Silver finish is only offered on flat aluminum trim.

Preconfigured Intersection Conditions

Adjustable Wall Mount

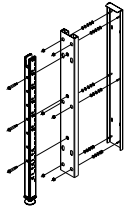
	MODEL	W x H x D	MODEL NUMBER		Approx. Packaged Weight
			Basic Model	Trim Color	
 <p>HRDPT</p>	Wall Track	2 1/2 x 31 x 1"	PWT30	<input type="checkbox"/>	2.0#
	• Double slotted track accommodates wall mounting of overhead components and worksurfaces	2 1/2 x 37 x 1"	PWT36	<input type="checkbox"/>	2.0#
	• Steel construction with painted finish	2 1/2 x 43 x 1"	PWT42	<input type="checkbox"/>	3.0#
	• No hardware for wall attachment is included	2 1/2 x 49 x 1"	PWT48	<input type="checkbox"/>	3.0#
	• See installation guidelines	2 1/2 x 55 x 1"	PWT54	<input type="checkbox"/>	3.0#
	• SX Starlight Silver finish is only offered on flat aluminum trim	2 1/2 x 61 x 1"	PWT60	<input type="checkbox"/>	4.0#
		2 1/2 x 67 x 1"	PWT66	<input type="checkbox"/>	4.0#
		2 1/2 x 73 x 1"	PWT72	<input type="checkbox"/>	4.0#
		2 1/2 x 79 x 1"	PWT78	<input type="checkbox"/>	5.0#
		2 1/2 x 85 x 1"	PWT84	<input type="checkbox"/>	5.0#
 <p>HRDPT</p>	Adjustable Wall Mount	2 1/2 x 30 x 1"	PWM30	<input type="checkbox"/>	11.0#
	• Attaches a panel to a wall at the start of a run	2 1/2 x 36 x 1"	PWM36	<input type="checkbox"/>	13.0#
	• Includes mounting plate and half-post	2 1/2 x 42 x 1"	PWM42	<input type="checkbox"/>	15.0#
	• Steel construction with painted finish	2 1/2 x 48 x 1"	PWM48	<input type="checkbox"/>	17.0#
	• Hardware for wall attachment is not included	2 1/2 x 54 x 1"	PWM54	<input type="checkbox"/>	19.0#
	• Adjustable up to 3/4" to correct wall deflection	2 1/2 x 60 x 1"	PWM60	<input type="checkbox"/>	23.0#
	• SX Starlight Silver finish is only offered on flat aluminum trim	2 1/2 x 66 x 1"	PWM66	<input type="checkbox"/>	23.0#
		2 1/2 x 72 x 1"	PWM72	<input type="checkbox"/>	25.0#
		2 1/2 x 78 x 1"	PWM78	<input type="checkbox"/>	23.0#
		2 1/2 x 84 x 1"	PWM84	<input type="checkbox"/>	30.0#

A

B

HOW TO ORDER

Indicate the following information on order form:

- Quantity of each item.
- Model number, including options. See "How To Build a Model Number".
- Any special service required.

Note: • The indicates that a choice is required.

- The absence of the indicates that no choice is required.
- Alpha-numeric characters in place of indicate that no other alternatives are available.

HOW TO BUILD A MODEL NUMBER

A Select basic model.

B Select trim color.

Refer to the **Product Color Options** page in this catalog. SX Starlight Silver finish is only offered on flat aluminum trim.

Preconfigured Intersection Conditions

180° 2-Way

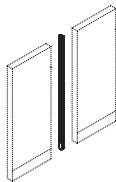
	MODEL	A	B	A-B	MODEL NUMBER	Approx. Packaged Weight
					Basic Model	
 <p>P1TN - KD1 PTN - Pass Through</p>	180° 2-Way In-Line Connection, Both Panels Same Height <ul style="list-style-type: none"> • Unupholstered • Full-height post 	30"			PFP30	4.0#
		36"			PFP36	5.0#
		42"			PFP42	5.0#
		48"			PFP48	6.0#
		54"			PFP54	6.0#
		60"			PFP60	7.0#
		66"			PFP66	7.0#
		72"			PFP72	8.0#
		78"			PFP78	8.0#
		84"			PFP84	9.0#

A

HOW TO ORDER

Indicate the following information on order form:

1. Quantity of each item.
2. Model number, including options. See "How To Build a Model Number".
3. Any special service required.

Note: • The indicates that a choice is required.

- The absence of the indicates that no choice is required.
- Alpha-numeric characters in place of indicate that no other alternatives are available.

HOW TO BUILD A MODEL NUMBER

A Select basic model.

Preconfigured Intersection Conditions

180° 2-Way

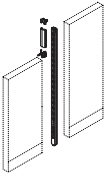
MODEL	A B A-B	MODEL NUMBER		Approx. Packaged Weight
		Basic Model	Trim Color	
 <p>P1TN - KD1 PTN - Pass Through</p> <p>180° 2-Way In-Line Connection, Two Different Heights</p> <ul style="list-style-type: none"> • Unupholstered: trim colored • Full height post • In-line height change trim • In-line height change bottom cap • End-of-run top cap • SX Starlight Silver finish is only offered on flat aluminum trim 	36" 30" 6"	PFPV3036	<input type="checkbox"/>	4.0#
	42" 30" 12"	PFPV3042	<input type="checkbox"/>	6.0#
	48" 30" 18"	PFPV3048	<input type="checkbox"/>	6.0#
	54" 30" 24"	PFPV3054	<input type="checkbox"/>	7.0#
	66" 30" 36"	PFPV3066	<input type="checkbox"/>	8.0#
	72" 30" 42"	PFPV3072	<input type="checkbox"/>	10.0#
	84" 30" 54"	PFPV3084	<input type="checkbox"/>	11.0#
	42" 36" 6"	PFPV3642	<input type="checkbox"/>	5.0#
	48" 36" 12"	PFPV3648	<input type="checkbox"/>	6.0#
	54" 36" 18"	PFPV3654	<input type="checkbox"/>	7.0#
	66" 36" 30"	PFPV3666	<input type="checkbox"/>	8.0#
	72" 36" 36"	PFPV3672	<input type="checkbox"/>	9.0#
	84" 36" 48"	PFPV3684	<input type="checkbox"/>	11.0#
	48" 42" 6"	PFPV4248	<input type="checkbox"/>	6.0#
	54" 42" 12"	PFPV4254	<input type="checkbox"/>	7.0#
	66" 42" 24"	PFPV4266	<input type="checkbox"/>	8.0#
	72" 42" 30"	PFPV4272	<input type="checkbox"/>	9.0#
	84" 42" 42"	PFPV4284	<input type="checkbox"/>	11.0#
	54" 48" 6"	PFPV4854	<input type="checkbox"/>	6.0#
	66" 48" 18"	PFPV4866	<input type="checkbox"/>	8.0#
	72" 48" 24"	PFPV4872	<input type="checkbox"/>	9.0#
	84" 48" 36"	PFPV4884	<input type="checkbox"/>	11.0#
	66" 54" 12"	PFPV5466	<input type="checkbox"/>	8.0#
	72" 54" 18"	PFPV5472	<input type="checkbox"/>	9.0#
	84" 54" 30"	PFPV5484	<input type="checkbox"/>	11.0#
	72" 66" 6"	PFPV6672	<input type="checkbox"/>	8.0#
	84" 66" 18"	PFPV6684	<input type="checkbox"/>	10.0#
	84" 72" 12"	PFPV7284	<input type="checkbox"/>	10.0#

A

B

HOW TO ORDER

Indicate the following information on order form:

1. Quantity of each item.
2. Model number, including options. See "How To Build a Model Number".
3. Any special service required.

Note: • The indicates that a choice is required.

- The absence of the indicates that no choice is required.
- Alpha-numeric characters in place of indicate that no other alternatives are available.

HOW TO BUILD A MODEL NUMBER

A Select basic model.

B Select trim color.

Refer to the **Product Color Options** page in this catalog.
SX Starlight Silver finish is only offered on flat aluminum trim.

Preconfigured Intersection Conditions

180° 2-Way

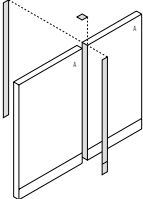
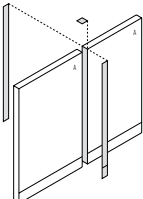
	MODEL	A	MODEL NUMBER				Approx. Packaged Weight
			Basic Model	Assembly	Trim Color	Fabric Color	
 <p>P1TN - KD1 PTN - Pass Through</p>	180° 2-Way In-Line Spacer, Both Panels Same Height	30"	PSP18030	<input type="checkbox"/>	<input type="checkbox"/>		7.0#
		36"	PSP18036	<input type="checkbox"/>	<input type="checkbox"/>		9.0#
	• Unupholstered: trim colored	42"	PSP18042	<input type="checkbox"/>	<input type="checkbox"/>		10.0#
	• 180° top cap	48"	PSP18048	<input type="checkbox"/>	<input type="checkbox"/>		13.0#
	• Two pieces of universal trim	54"	PSP18054	<input type="checkbox"/>	<input type="checkbox"/>		15.0#
	• Two pieces of 3-way base trim	60"	PSP18060	<input type="checkbox"/>	<input type="checkbox"/>		16.0#
	• Two half-posts	66"	PSP18066	<input type="checkbox"/>	<input type="checkbox"/>		16.0#
	• Connecting hardware	72"	PSP18072	<input type="checkbox"/>	<input type="checkbox"/>		18.0#
	• SX Starlight Silver finish is only offered on flat aluminum trim	78"	PSP18078	<input type="checkbox"/>	<input type="checkbox"/>		18.0#
		84"	PSP18084	<input type="checkbox"/>	<input type="checkbox"/>		20.0#
 <p>P1TF - KD1 PITNF - Pass Through</p>	180° 2-Way In-Line Spacer, Both Panels Same Height	30"	PSPF18030	<input type="checkbox"/>	<input type="checkbox"/>	<input type="checkbox"/>	7.0#
		36"	PSPF18036	<input type="checkbox"/>	<input type="checkbox"/>	<input type="checkbox"/>	9.0#
	• Upholstered	42"	PSPF18042	<input type="checkbox"/>	<input type="checkbox"/>	<input type="checkbox"/>	10.0#
	• 180° top cap	48"	PSPF18048	<input type="checkbox"/>	<input type="checkbox"/>	<input type="checkbox"/>	13.0#
	• Two fabric-wrapped pieces of universal trim	54"	PSPF18054	<input type="checkbox"/>	<input type="checkbox"/>	<input type="checkbox"/>	15.0#
	• Two pieces of 3-way base trim	60"	PSPF18060	<input type="checkbox"/>	<input type="checkbox"/>	<input type="checkbox"/>	16.0#
	• Two half-posts	66"	PSPF18066	<input type="checkbox"/>	<input type="checkbox"/>	<input type="checkbox"/>	16.0#
	• Connecting hardware	72"	PSPF18072	<input type="checkbox"/>	<input type="checkbox"/>	<input type="checkbox"/>	18.0#
	• SX Starlight Silver finish is only offered on flat aluminum trim	78"	PSPF18078	<input type="checkbox"/>	<input type="checkbox"/>	<input type="checkbox"/>	18.0#
		84"	PSPF18084	<input type="checkbox"/>	<input type="checkbox"/>	<input type="checkbox"/>	20.0#
			A	B	C	D	

HOW TO ORDER

Indicate the following information on order form:

- Quantity of each item.
- Model number, including options. See "How To Build a Model Number".
- Any special service required.

Note: • The indicates that a choice is required.
• The absence of the indicates that no choice is required.
• Alpha-numeric characters in place of indicate that no other alternatives are available.

HOW TO BUILD A MODEL NUMBER

A Select basic model.

B Select assembly.

F - Fully Assembled
U - Unassembled

C Select trim color.
Refer to the **Product Color Options** page in this catalog.
SX Starlight Silver finish is only offered on flat aluminum trim.

D Select fabric color.

Preconfigured Intersection Conditions

180° 2-Way

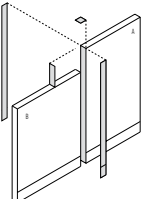
MODEL	A B A-B	MODEL NUMBER		Approx. Packaged Weight
		Basic Model	Trim Color	
 <p>P1TN - KD1 PTN - Pass Through</p> <p>180° 2-Way In-Line Spacer, Two Different Heights</p> <ul style="list-style-type: none"> • Upholstered: trim colored • Two pieces of 3-way base trim • 1-way top cap • Two pieces of universal trim • One piece of universal height change trim • One half-post (height A) • One half-post (height B) • Connecting hardware • SX Starlight Silver finish is only offered on flat aluminum trim 	36" 30" 6"	PSPV1803036	<input type="checkbox"/>	10.0#
	42" 30" 12"	PSPV1803042	<input type="checkbox"/>	9.0#
	48" 30" 18"	PSPV1803048	<input type="checkbox"/>	12.0#
	54" 30" 24"	PSPV1803054	<input type="checkbox"/>	11.0#
	66" 30" 36"	PSPV1803066	<input type="checkbox"/>	13.0#
	72" 30" 42"	PSPV1803072	<input type="checkbox"/>	17.0#
	84" 30" 54"	PSPV1803084	<input type="checkbox"/>	16.0#
	42" 36" 6"	PSPV1803642	<input type="checkbox"/>	11.0#
	48" 36" 12"	PSPV1803648	<input type="checkbox"/>	12.0#
	54" 36" 18"	PSPV1803654	<input type="checkbox"/>	14.0#
	66" 36" 30"	PSPV1803666	<input type="checkbox"/>	16.0#
	72" 36" 36"	PSPV1803672	<input type="checkbox"/>	17.0#
	84" 36" 48"	PSPV1803684	<input type="checkbox"/>	19.0#
	48" 42" 6"	PSPV1804248	<input type="checkbox"/>	13.0#
	54" 42" 12"	PSPV1804254	<input type="checkbox"/>	12.0#
	66" 42" 24"	PSPV1804266	<input type="checkbox"/>	14.0#
	72" 42" 30"	PSPV1804272	<input type="checkbox"/>	18.0#
	84" 42" 42"	PSPV1804284	<input type="checkbox"/>	17.0#
	54" 48" 6"	PSPV1804854	<input type="checkbox"/>	14.0#
	66" 48" 18"	PSPV1804866	<input type="checkbox"/>	17.0#
	72" 48" 24"	PSPV1804872	<input type="checkbox"/>	18.0#
	84" 48" 36"	PSPV1804884	<input type="checkbox"/>	20.0#
	66" 54" 12"	PSPV1805466	<input type="checkbox"/>	15.0#
	72" 54" 18"	PSPV1805472	<input type="checkbox"/>	18.0#
	84" 54" 30"	PSPV1805484	<input type="checkbox"/>	18.0#
	72" 66" 6"	PSPV1806672	<input type="checkbox"/>	18.0#
	84" 66" 18"	PSPV1806684	<input type="checkbox"/>	19.0#
	84" 72" 12"	PSPV1807284	<input type="checkbox"/>	21.0#

A

B

HOW TO ORDER

Indicate the following information on order form:

1. Quantity of each item.
2. Model number, including options. See "How To Build a Model Number".
3. Any special service required.

Note: • The indicates that a choice is required.

- The absence of the indicates that no choice is required.

- Alpha-numeric characters in place of indicate that no other alternatives are available.

HOW TO BUILD A MODEL NUMBER

A Select basic model.

B Select trim color.

Refer to the **Product Color Options** page in this catalog.

SX Starlight Silver finish is only offered on flat aluminum trim.

Preconfigured Intersection Conditions

180° 2-Way

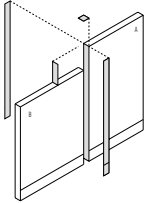
	MODEL	A	B	A-B	MODEL NUMBER			Approx. Packaged Weight
					Basic Model	Trim Color	Fabric Color	
 <p>P1TF - KD1 PTNF - Pass Through</p>	180° 2-Way In-Line Spacer, Two Different Heights	36"	30"	6"	PSPVF1803036	<input type="checkbox"/>	<input type="checkbox"/> <input type="checkbox"/> <input type="checkbox"/> <input type="checkbox"/>	10.0#
		42"	30"	12"	PSPVF1803042	<input type="checkbox"/>	<input type="checkbox"/> <input type="checkbox"/> <input type="checkbox"/> <input type="checkbox"/>	9.0#
	• Upholstered	48"	30"	18"	PSPVF1803048	<input type="checkbox"/>	<input type="checkbox"/> <input type="checkbox"/> <input type="checkbox"/> <input type="checkbox"/>	12.0#
	• Two pieces of 3-way base trim	54"	30"	24"	PSPVF1803054	<input type="checkbox"/>	<input type="checkbox"/> <input type="checkbox"/> <input type="checkbox"/> <input type="checkbox"/>	11.0#
	• 1-way top cap	66"	30"	36"	PSPVF1803066	<input type="checkbox"/>	<input type="checkbox"/> <input type="checkbox"/> <input type="checkbox"/> <input type="checkbox"/>	13.0#
	• Two fabric-wrapped pieces of universal trim	72"	30"	42"	PSPVF1803072	<input type="checkbox"/>	<input type="checkbox"/> <input type="checkbox"/> <input type="checkbox"/> <input type="checkbox"/>	17.0#
	• One fabric-wrapped piece of universal height change trim	84"	30"	54"	PSPVF1803084	<input type="checkbox"/>	<input type="checkbox"/> <input type="checkbox"/> <input type="checkbox"/> <input type="checkbox"/>	16.0#
	• One half-post (height A)	42"	36"	6"	PSPVF1803642	<input type="checkbox"/>	<input type="checkbox"/> <input type="checkbox"/> <input type="checkbox"/> <input type="checkbox"/>	11.0#
	• One half-post (height B)	48"	36"	12"	PSPVF1803648	<input type="checkbox"/>	<input type="checkbox"/> <input type="checkbox"/> <input type="checkbox"/> <input type="checkbox"/>	12.0#
	• Connecting hardware	54"	36"	18"	PSPVF1803654	<input type="checkbox"/>	<input type="checkbox"/> <input type="checkbox"/> <input type="checkbox"/> <input type="checkbox"/>	14.0#
	• SX Starlight Silver finish is only offered on flat aluminum trim	66"	36"	30"	PSPVF1803666	<input type="checkbox"/>	<input type="checkbox"/> <input type="checkbox"/> <input type="checkbox"/> <input type="checkbox"/>	16.0#
		72"	36"	36"	PSPVF1803672	<input type="checkbox"/>	<input type="checkbox"/> <input type="checkbox"/> <input type="checkbox"/> <input type="checkbox"/>	17.0#
		84"	36"	48"	PSPVF1803684	<input type="checkbox"/>	<input type="checkbox"/> <input type="checkbox"/> <input type="checkbox"/> <input type="checkbox"/>	19.0#
		48"	42"	6"	PSPVF1804248	<input type="checkbox"/>	<input type="checkbox"/> <input type="checkbox"/> <input type="checkbox"/> <input type="checkbox"/>	13.0#
		54"	42"	12"	PSPVF1804254	<input type="checkbox"/>	<input type="checkbox"/> <input type="checkbox"/> <input type="checkbox"/> <input type="checkbox"/>	12.0#
		66"	42"	24"	PSPVF1804266	<input type="checkbox"/>	<input type="checkbox"/> <input type="checkbox"/> <input type="checkbox"/> <input type="checkbox"/>	14.0#
		72"	42"	30"	PSPVF1804272	<input type="checkbox"/>	<input type="checkbox"/> <input type="checkbox"/> <input type="checkbox"/> <input type="checkbox"/>	18.0#
		84"	42"	42"	PSPVF1804284	<input type="checkbox"/>	<input type="checkbox"/> <input type="checkbox"/> <input type="checkbox"/> <input type="checkbox"/>	17.0#
		54"	48"	6"	PSPVF1804854	<input type="checkbox"/>	<input type="checkbox"/> <input type="checkbox"/> <input type="checkbox"/> <input type="checkbox"/>	14.0#
		66"	48"	18"	PSPVF1804866	<input type="checkbox"/>	<input type="checkbox"/> <input type="checkbox"/> <input type="checkbox"/> <input type="checkbox"/>	17.0#
		72"	48"	24"	PSPVF1804872	<input type="checkbox"/>	<input type="checkbox"/> <input type="checkbox"/> <input type="checkbox"/> <input type="checkbox"/>	18.0#
		84"	48"	36"	PSPVF1804884	<input type="checkbox"/>	<input type="checkbox"/> <input type="checkbox"/> <input type="checkbox"/> <input type="checkbox"/>	20.0#
		66"	54"	12"	PSPVF1805466	<input type="checkbox"/>	<input type="checkbox"/> <input type="checkbox"/> <input type="checkbox"/> <input type="checkbox"/>	15.0#
		72"	54"	18"	PSPVF1805472	<input type="checkbox"/>	<input type="checkbox"/> <input type="checkbox"/> <input type="checkbox"/> <input type="checkbox"/>	18.0#
		84"	54"	30"	PSPVF1805484	<input type="checkbox"/>	<input type="checkbox"/> <input type="checkbox"/> <input type="checkbox"/> <input type="checkbox"/>	18.0#
		72"	66"	6"	PSPVF1806672	<input type="checkbox"/>	<input type="checkbox"/> <input type="checkbox"/> <input type="checkbox"/> <input type="checkbox"/>	18.0#
		84"	66"	18"	PSPVF1806684	<input type="checkbox"/>	<input type="checkbox"/> <input type="checkbox"/> <input type="checkbox"/> <input type="checkbox"/>	19.0#
		84"	72"	12"	PSPVF1807284	<input type="checkbox"/>	<input type="checkbox"/> <input type="checkbox"/> <input type="checkbox"/> <input type="checkbox"/>	21.0#

A

B

C

HOW TO ORDER

Indicate the following information on order form:

- Quantity of each item.
- Model number, including options. See "How To Build a Model Number".
- Any special service required.

Note: • The indicates that a choice is required.

- The absence of the indicates that no choice is required.
- Alpha-numeric characters in place of indicate that no other alternatives are available.

HOW TO BUILD A MODEL NUMBER

- A** Select basic model.
- B** Select trim color.
Refer to the **Product Color Options** page in this catalog.
SX Starlight Silver finish is only offered on flat aluminum trim.
- C** Select fabric color.

Preconfigured Intersection Conditions

3-Way

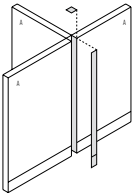
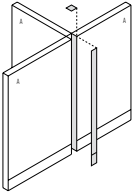
	MODEL	A	MODEL NUMBER				Approx. Packaged Weight
			Basic Model	Assembly	Trim Color	Fabric Color	
 <p>P1TN - KD1 PTN - Pass Through</p>	3-Way "T" Intersection w/3-Way Cap, All Panels Same Height - AAA <ul style="list-style-type: none"> • Unupholstered • 3-way top cap • 3-way base trim • One piece of universal trim • Light block • Three half-posts • Connecting hardware • SX Starlight Silver finish is only offered on flat aluminum trim 	30"	PTP3W30	<input type="checkbox"/>	<input type="checkbox"/>		9.0#
		36"	PTP3W36	<input type="checkbox"/>	<input type="checkbox"/>		9.0#
		42"	PTP3W42	<input type="checkbox"/>	<input type="checkbox"/>		12.0#
		48"	PTP3W48	<input type="checkbox"/>	<input type="checkbox"/>		12.0#
		54"	PTP3W54	<input type="checkbox"/>	<input type="checkbox"/>		15.0#
		60"	PTP3W60	<input type="checkbox"/>	<input type="checkbox"/>		15.0#
		66"	PTP3W66	<input type="checkbox"/>	<input type="checkbox"/>		18.0#
		72"	PTP3W72	<input type="checkbox"/>	<input type="checkbox"/>		18.0#
		78"	PTP3W78	<input type="checkbox"/>	<input type="checkbox"/>		20.0#
		84"	PTP3W84	<input type="checkbox"/>	<input type="checkbox"/>		22.0#
 <p>P1TF - KD1 PTF - Pass Through</p>	3-Way "T" Intersection w/3-Way Cap, All Panels Same Height - AAA <ul style="list-style-type: none"> • Upholstered • 3-way top cap • 3-way base trim • One piece of fabric-wrapped universal trim • Light block • Three half-posts • Connecting hardware • SX Starlight Silver finish is only offered on flat aluminum trim 	30"	PTPF3W30	<input type="checkbox"/>	<input type="checkbox"/>	<input type="checkbox"/> <input type="checkbox"/> <input type="checkbox"/> <input type="checkbox"/>	9.0#
		36"	PTPF3W36	<input type="checkbox"/>	<input type="checkbox"/>	<input type="checkbox"/> <input type="checkbox"/> <input type="checkbox"/> <input type="checkbox"/>	9.0#
		42"	PTPF3W42	<input type="checkbox"/>	<input type="checkbox"/>	<input type="checkbox"/> <input type="checkbox"/> <input type="checkbox"/> <input type="checkbox"/>	12.0#
		48"	PTPF3W48	<input type="checkbox"/>	<input type="checkbox"/>	<input type="checkbox"/> <input type="checkbox"/> <input type="checkbox"/> <input type="checkbox"/>	12.0#
		54"	PTPF3W54	<input type="checkbox"/>	<input type="checkbox"/>	<input type="checkbox"/> <input type="checkbox"/> <input type="checkbox"/> <input type="checkbox"/>	15.0#
		60"	PTPF3W60	<input type="checkbox"/>	<input type="checkbox"/>	<input type="checkbox"/> <input type="checkbox"/> <input type="checkbox"/> <input type="checkbox"/>	15.0#
		66"	PTPF3W66	<input type="checkbox"/>	<input type="checkbox"/>	<input type="checkbox"/> <input type="checkbox"/> <input type="checkbox"/> <input type="checkbox"/>	18.0#
		72"	PTPF3W72	<input type="checkbox"/>	<input type="checkbox"/>	<input type="checkbox"/> <input type="checkbox"/> <input type="checkbox"/> <input type="checkbox"/>	18.0#
		78"	PTPF3W78	<input type="checkbox"/>	<input type="checkbox"/>	<input type="checkbox"/> <input type="checkbox"/> <input type="checkbox"/> <input type="checkbox"/>	20.0#
		84"	PTPF3W84	<input type="checkbox"/>	<input type="checkbox"/>	<input type="checkbox"/> <input type="checkbox"/> <input type="checkbox"/> <input type="checkbox"/>	22.0#

A

B

C

D

HOW TO ORDER

Indicate the following information on order form:

1. Quantity of each item.
2. Model number, including options. See "How To Build a Model Number".
3. Any special service required.

Note: • The indicates that a choice is required.
• The absence of the indicates that no choice is required.
• Alpha-numeric characters in place of indicate that no other alternatives are available.

HOW TO BUILD A MODEL NUMBER

A Select basic model.

B Select assembly.

F - Fully Assembled
U - Unassembled

C Select trim color.

Refer to the **Product Color Options** page in this catalog.
SX Starlight Silver finish is only offered on flat aluminum trim.

D Select fabric color.

Preconfigured Intersection Conditions

3-Way

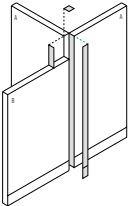
	MODEL	A	B	A-B	MODEL NUMBER		Approx. Packaged Weight
					Basic Model	Trim Color	
 <p>P1TN - KD1 PTN - Pass Through</p>	3-Way "T" Intersection w/90° Top Cap, Two Different Heights - BAA	36"	30"	6"	PTPV903036	<input type="checkbox"/>	10.0#
		42"	30"	12"	PTPV903042	<input type="checkbox"/>	10.0#
	• Unupholstered: trim colored	48"	30"	18"	PTPV903048	<input type="checkbox"/>	11.0#
	• 90° top cap	54"	30"	24"	PTPV903054	<input type="checkbox"/>	12.0#
	• 3-way base trim	66"	30"	36"	PTPV903066	<input type="checkbox"/>	14.0#
	• One piece of universal height change trim	72"	30"	42"	PTPV903072	<input type="checkbox"/>	12.0#
	• Light block	84"	30"	54"	PTPV903084	<input type="checkbox"/>	16.0#
	• Two half-posts (height A)	42"	36"	6"	PTPV903642	<input type="checkbox"/>	14.0#
	• One half-post (height B)	48"	36"	12"	PTPV903648	<input type="checkbox"/>	16.0#
	• Connecting hardware	54"	36"	18"	PTPV903654	<input type="checkbox"/>	14.0#
	• SX Starlight Silver finish is only offered on flat aluminum trim	66"	36"	30"	PTPV903666	<input type="checkbox"/>	16.0#
		72"	36"	36"	PTPV903672	<input type="checkbox"/>	18.0#
		84"	36"	48"	PTPV903684	<input type="checkbox"/>	17.0#
		48"	42"	6"	PTPV904248	<input type="checkbox"/>	19.0#
		54"	42"	12"	PTPV904254	<input type="checkbox"/>	14.0#
		66"	42"	24"	PTPV904266	<input type="checkbox"/>	16.0#
		72"	42"	30"	PTPV904272	<input type="checkbox"/>	22.0#
		84"	42"	42"	PTPV904284	<input type="checkbox"/>	18.0#
		54"	48"	6"	PTPV904854	<input type="checkbox"/>	10.0#
		66"	48"	18"	PTPV904866	<input type="checkbox"/>	12.0#
		72"	48"	24"	PTPV904872	<input type="checkbox"/>	14.0#
		84"	48"	36"	PTPV904884	<input type="checkbox"/>	16.0#
		66"	54"	12"	PTPV905466	<input type="checkbox"/>	17.0#
		72"	54"	18"	PTPV905472	<input type="checkbox"/>	14.0#
		84"	54"	30"	PTPV905484	<input type="checkbox"/>	19.0#
		72"	66"	6"	PTPV906672	<input type="checkbox"/>	16.0#
		84"	66"	18"	PTPV906684	<input type="checkbox"/>	22.0#
		84"	72"	12"	PTPV907284	<input type="checkbox"/>	18.0#

A

B

HOW TO ORDER

Indicate the following information on order form:

- Quantity of each item.
- Model number, including options. See "How To Build a Model Number".
- Any special service required.

Note: • The indicates that a choice is required.

- The absence of the indicates that no choice is required.
- Alpha-numeric characters in place of indicate that no other alternatives are available.

HOW TO BUILD A MODEL NUMBER

A Select basic model.

B Select trim color.

Refer to the **Product Color Options** page in this catalog.

SX Starlight Silver finish is only offered on flat aluminum trim.

Preconfigured Intersection Conditions

3-Way

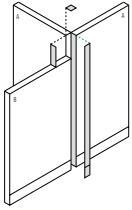
	MODEL	A	B	A-B	MODEL NUMBER			Approx. Packaged Weight
					Basic Model	Trim Color	Fabric Color	
 <p>P1TF - KD1 PTNF - Pass Through</p>	3-Way "T" Intersection w/90° Top Cap, Two Different Heights - BAA	36"	30"	6"	PTPVF903036	<input type="checkbox"/>	<input type="checkbox"/> <input type="checkbox"/> <input type="checkbox"/> <input type="checkbox"/>	12.0#
		42"	30"	12"	PTPVF903042	<input type="checkbox"/>	<input type="checkbox"/> <input type="checkbox"/> <input type="checkbox"/> <input type="checkbox"/>	11.0#
	• Upholstered	48"	30"	18"	PTPVF903048	<input type="checkbox"/>	<input type="checkbox"/> <input type="checkbox"/> <input type="checkbox"/> <input type="checkbox"/>	16.0#
	• 90° top cap	54"	30"	24"	PTPVF903054	<input type="checkbox"/>	<input type="checkbox"/> <input type="checkbox"/> <input type="checkbox"/> <input type="checkbox"/>	14.0#
	• 3-way base trim	66"	30"	36"	PTPVF903066	<input type="checkbox"/>	<input type="checkbox"/> <input type="checkbox"/> <input type="checkbox"/> <input type="checkbox"/>	17.0#
	• One piece of fabric-wrapped universal trim	72"	30"	42"	PTPVF903072	<input type="checkbox"/>	<input type="checkbox"/> <input type="checkbox"/> <input type="checkbox"/> <input type="checkbox"/>	22.0#
	• One piece of universal height change trim	84"	30"	54"	PTPVF903084	<input type="checkbox"/>	<input type="checkbox"/> <input type="checkbox"/> <input type="checkbox"/> <input type="checkbox"/>	21.0#
	• Light block	42"	36"	6"	PTPVF903642	<input type="checkbox"/>	<input type="checkbox"/> <input type="checkbox"/> <input type="checkbox"/> <input type="checkbox"/>	14.0#
	• Two half-posts (height A)	48"	36"	12"	PTPVF903648	<input type="checkbox"/>	<input type="checkbox"/> <input type="checkbox"/> <input type="checkbox"/> <input type="checkbox"/>	16.0#
	• One half-post (height B)	54"	36"	18"	PTPVF903654	<input type="checkbox"/>	<input type="checkbox"/> <input type="checkbox"/> <input type="checkbox"/> <input type="checkbox"/>	17.0#
	• Connecting hardware	66"	36"	30"	PTPVF903666	<input type="checkbox"/>	<input type="checkbox"/> <input type="checkbox"/> <input type="checkbox"/> <input type="checkbox"/>	20.0#
	• SX Starlight Silver finish is only offered on flat aluminum trim	72"	36"	36"	PTPVF903672	<input type="checkbox"/>	<input type="checkbox"/> <input type="checkbox"/> <input type="checkbox"/> <input type="checkbox"/>	22.0#
		84"	36"	48"	PTPVF903684	<input type="checkbox"/>	<input type="checkbox"/> <input type="checkbox"/> <input type="checkbox"/> <input type="checkbox"/>	25.0#
		48"	42"	6"	PTPVF904248	<input type="checkbox"/>	<input type="checkbox"/> <input type="checkbox"/> <input type="checkbox"/> <input type="checkbox"/>	16.0#
		54"	42"	12"	PTPVF904254	<input type="checkbox"/>	<input type="checkbox"/> <input type="checkbox"/> <input type="checkbox"/> <input type="checkbox"/>	15.0#
		66"	42"	24"	PTPVF904266	<input type="checkbox"/>	<input type="checkbox"/> <input type="checkbox"/> <input type="checkbox"/> <input type="checkbox"/>	18.0#
		72"	42"	30"	PTPVF904272	<input type="checkbox"/>	<input type="checkbox"/> <input type="checkbox"/> <input type="checkbox"/> <input type="checkbox"/>	23.0#
		84"	42"	42"	PTPVF904284	<input type="checkbox"/>	<input type="checkbox"/> <input type="checkbox"/> <input type="checkbox"/> <input type="checkbox"/>	22.0#
		54"	48"	6"	PTPVF904854	<input type="checkbox"/>	<input type="checkbox"/> <input type="checkbox"/> <input type="checkbox"/> <input type="checkbox"/>	18.0#
		66"	48"	18"	PTPVF904866	<input type="checkbox"/>	<input type="checkbox"/> <input type="checkbox"/> <input type="checkbox"/> <input type="checkbox"/>	21.0#
		72"	48"	24"	PTPVF904872	<input type="checkbox"/>	<input type="checkbox"/> <input type="checkbox"/> <input type="checkbox"/> <input type="checkbox"/>	23.0#
		84"	48"	36"	PTPVF904884	<input type="checkbox"/>	<input type="checkbox"/> <input type="checkbox"/> <input type="checkbox"/> <input type="checkbox"/>	26.0#
		66"	54"	12"	PTPVF905466	<input type="checkbox"/>	<input type="checkbox"/> <input type="checkbox"/> <input type="checkbox"/> <input type="checkbox"/>	18.0#
		72"	54"	18"	PTPVF905472	<input type="checkbox"/>	<input type="checkbox"/> <input type="checkbox"/> <input type="checkbox"/> <input type="checkbox"/>	23.0#
		84"	54"	30"	PTPVF905484	<input type="checkbox"/>	<input type="checkbox"/> <input type="checkbox"/> <input type="checkbox"/> <input type="checkbox"/>	22.0#
		72"	66"	6"	PTPVF906672	<input type="checkbox"/>	<input type="checkbox"/> <input type="checkbox"/> <input type="checkbox"/> <input type="checkbox"/>	23.0#
		84"	66"	18"	PTPVF906684	<input type="checkbox"/>	<input type="checkbox"/> <input type="checkbox"/> <input type="checkbox"/> <input type="checkbox"/>	23.0#
		84"	72"	12"	PTPVF907284	<input type="checkbox"/>	<input type="checkbox"/> <input type="checkbox"/> <input type="checkbox"/> <input type="checkbox"/>	26.0#

A

B

C

HOW TO ORDER

Indicate the following information on order form:

- Quantity of each item.
- Model number, including options. See "How To Build a Model Number".
- Any special service required.

Note: • The indicates that a choice is required.

- The absence of the indicates that no choice is required.
- Alpha-numeric characters in place of indicate that no other alternatives are available.

HOW TO BUILD A MODEL NUMBER

A Select basic model.

B Select trim color.
Refer to the **Product Color Options** page in this catalog.
SX Starlight Silver finish is only offered on flat aluminum trim.

C Select fabric color.

Preconfigured Intersection Conditions

3-Way

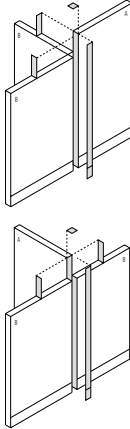
MODEL	A B A-B	MODEL NUMBER		Approx. Packaged Weight
		Basic Model	Trim Color	
 <p>P1TN - KD1 PTN - Pass Through</p> <p>3-Way "T" Intersection w/1-Way Cap, Two Different Heights - BBA or BAB</p> <ul style="list-style-type: none"> • Unupholstered: trim colored • 1-way top cap • One piece of universal trim • Two pieces of universal height change trim • Light block • 3-way base trim • One half-post (height A) • Two half-posts (height B) • Connecting hardware • SX Starlight Silver finish is only offered on flat aluminum trim 	36" 30" 6"	PTPV1W3036	<input type="checkbox"/>	12.0#
	42" 30" 12"	PTPV1W3042	<input type="checkbox"/>	10.0#
	48" 30" 18"	PTPV1W3048	<input type="checkbox"/>	15.0#
	54" 30" 24"	PTPV1W3054	<input type="checkbox"/>	14.0#
	66" 30" 36"	PTPV1W3066	<input type="checkbox"/>	16.0#
	72" 30" 42"	PTPV1W3072	<input type="checkbox"/>	20.0#
	84" 30" 54"	PTPV1W3084	<input type="checkbox"/>	20.0#
	42" 36" 6"	PTPV1W3642	<input type="checkbox"/>	14.0#
	48" 36" 12"	PTPV1W3648	<input type="checkbox"/>	15.0#
	54" 36" 18"	PTPV1W3654	<input type="checkbox"/>	16.0#
	66" 36" 30"	PTPV1W3666	<input type="checkbox"/>	18.0#
	72" 36" 36"	PTPV1W3672	<input type="checkbox"/>	20.0#
	84" 36" 48"	PTPV1W3684	<input type="checkbox"/>	23.0#
	48" 42" 6"	PTPV1W4248	<input type="checkbox"/>	16.0#
	54" 42" 12"	PTPV1W4254	<input type="checkbox"/>	13.0#
	66" 42" 24"	PTPV1W4266	<input type="checkbox"/>	15.0#
	72" 42" 30"	PTPV1W4272	<input type="checkbox"/>	21.0#
	84" 42" 42"	PTPV1W4284	<input type="checkbox"/>	17.0#
	54" 48" 6"	PTPV1W4854	<input type="checkbox"/>	17.0#
	66" 48" 18"	PTPV1W4866	<input type="checkbox"/>	20.0#
	72" 48" 24"	PTPV1W4872	<input type="checkbox"/>	21.0#
	84" 48" 36"	PTPV1W4884	<input type="checkbox"/>	23.0#
	66" 54" 12"	PTPV1W5466	<input type="checkbox"/>	18.0#
	72" 54" 18"	PTPV1W5472	<input type="checkbox"/>	22.0#
	84" 54" 30"	PTPV1W5484	<input type="checkbox"/>	20.0#
	72" 66" 6"	PTPV1W6672	<input type="checkbox"/>	23.0#
	84" 66" 18"	PTPV1W6684	<input type="checkbox"/>	21.0#
	84" 72" 12"	PTPV1W7284	<input type="checkbox"/>	26.0#

A

B

HOW TO ORDER

Indicate the following information on order form:

1. Quantity of each item.
2. Model number, including options. See "How To Build a Model Number".
3. Any special service required.

Note: • The indicates that a choice is required.

- The absence of the indicates that no choice is required.
- Alpha-numeric characters in place of indicate that no other alternatives are available.

HOW TO BUILD A MODEL NUMBER

A Select basic model.

B Select trim color.

Refer to the **Product Color Options** page in this catalog.

SX Starlight Silver finish is only offered on flat aluminum trim.

Preconfigured Intersection Conditions

3-Way

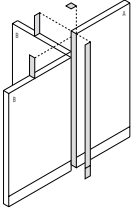
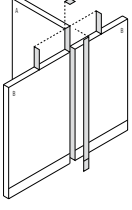
MODEL	A B A-B	MODEL NUMBER			Approx. Packaged Weight	
		Basic Model	Trim Color	Fabric Color		
	3-Way "T" Intersection w/1-Way Cap,	36" 30" 6"	PTPVF1W3036	<input type="checkbox"/>	<input type="checkbox"/>	12.0#
	Two Different Heights - BBA or BAB	42" 30" 12"	PTPVF1W3042	<input type="checkbox"/>	<input type="checkbox"/>	10.0#
	<ul style="list-style-type: none"> Upholstered 1-way top cap One fabric-wrapped piece of universal trim Two fabric-wrapped pieces of universal height change trim Light block 3-way base trim One half-post (height A) Two half-posts (height B) Connecting hardware SX Starlight Silver finish is only offered on flat aluminum trim 	48" 30" 18"	PTPVF1W3048	<input type="checkbox"/>	<input type="checkbox"/>	15.0#
	54" 30" 24"	PTPVF1W3054	<input type="checkbox"/>	<input type="checkbox"/>	14.0#	
	66" 30" 36"	PTPVF1W3066	<input type="checkbox"/>	<input type="checkbox"/>	16.0#	
	72" 30" 42"	PTPVF1W3072	<input type="checkbox"/>	<input type="checkbox"/>	20.0#	
	84" 30" 54"	PTPVF1W3084	<input type="checkbox"/>	<input type="checkbox"/>	20.0#	
	42" 36" 6"	PTPVF1W3642	<input type="checkbox"/>	<input type="checkbox"/>	14.0#	
	48" 36" 12"	PTPVF1W3648	<input type="checkbox"/>	<input type="checkbox"/>	15.0#	
	54" 36" 18"	PTPVF1W3654	<input type="checkbox"/>	<input type="checkbox"/>	16.0#	
	66" 36" 30"	PTPVF1W3666	<input type="checkbox"/>	<input type="checkbox"/>	18.0#	
	72" 36" 36"	PTPVF1W3672	<input type="checkbox"/>	<input type="checkbox"/>	20.0#	
	84" 36" 48"	PTPVF1W3684	<input type="checkbox"/>	<input type="checkbox"/>	23.0#	
	48" 42" 6"	PTPVF1W4248	<input type="checkbox"/>	<input type="checkbox"/>	16.0#	
	54" 42" 12"	PTPVF1W4254	<input type="checkbox"/>	<input type="checkbox"/>	13.0#	
	66" 42" 24"	PTPVF1W4266	<input type="checkbox"/>	<input type="checkbox"/>	15.0#	
	72" 42" 30"	PTPVF1W4272	<input type="checkbox"/>	<input type="checkbox"/>	21.0#	
	84" 42" 42"	PTPVF1W4284	<input type="checkbox"/>	<input type="checkbox"/>	17.0#	
	54" 48" 6"	PTPVF1W4854	<input type="checkbox"/>	<input type="checkbox"/>	17.0#	
	66" 48" 18"	PTPVF1W4866	<input type="checkbox"/>	<input type="checkbox"/>	19.0#	
	72" 48" 24"	PTPVF1W4872	<input type="checkbox"/>	<input type="checkbox"/>	21.0#	
	84" 48" 36"	PTPVF1W4884	<input type="checkbox"/>	<input type="checkbox"/>	23.0#	
66" 54" 12"	PTPVF1W5466	<input type="checkbox"/>	<input type="checkbox"/>	18.0#		
72" 54" 18"	PTPVF1W5472	<input type="checkbox"/>	<input type="checkbox"/>	22.0#		
84" 54" 30"	PTPVF1W5484	<input type="checkbox"/>	<input type="checkbox"/>	20.0#		
72" 66" 6"	PTPVF1W6672	<input type="checkbox"/>	<input type="checkbox"/>	23.0#		
84" 66" 18"	PTPVF1W6684	<input type="checkbox"/>	<input type="checkbox"/>	21.0#		
84" 72" 12"	PTPVF1W7284	<input type="checkbox"/>	<input type="checkbox"/>	26.0#		

P1TF - KD1

PTNF - Pass Through

A

B

C

HOW TO ORDER

Indicate the following information on order form:

- Quantity of each item.
- Model number, including options. See "How To Build a Model Number".
- Any special service required.

Note: • The indicates that a choice is required.

- The absence of the indicates that no choice is required.
- Alpha-numeric characters in place of indicate that no other alternatives are available.

HOW TO BUILD A MODEL NUMBER

- A** Select basic model.
- B** Select trim color.
Refer to the **Product Color Options** page in this catalog.
SX Starlight Silver finish is only offered on flat aluminum trim.
- C** Select fabric color.

Preconfigured Intersection Conditions

3-Way

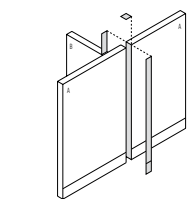

P1TN - KD1

PTN - Pass Through

MODEL

A B A-B

MODEL NUMBER

Basic Model

Trim Color

Approx. Packaged Weight

3-Way "T" Intersection w/180° Top Cap, Two Different Heights - ABA

- Unupholstered: trim colored
- 180° top cap
- One piece of universal trim
- One piece of universal height change trim
- Light block
- 3-way base trim
- Two half-posts (height A)
- One half-post (height B)
- Connecting hardware
- SX Starlight Silver finish is only offered on flat aluminum trim

MODEL	A B A-B	Basic Model	Trim Color	Approx. Packaged Weight
	36" 30" 6"	PTPV1803036	<input type="checkbox"/>	10.0#
	42" 30" 12"	PTPV1803042	<input type="checkbox"/>	10.0#
	48" 30" 18"	PTPV1803048	<input type="checkbox"/>	11.0#
	54" 30" 24"	PTPV1803054	<input type="checkbox"/>	12.0#
	66" 30" 36"	PTPV1803066	<input type="checkbox"/>	14.0#
	72" 30" 42"	PTPV1803072	<input type="checkbox"/>	12.0#
	84" 30" 54"	PTPV1803084	<input type="checkbox"/>	16.0#
	42" 36" 6"	PTPV1803642	<input type="checkbox"/>	14.0#
	48" 36" 12"	PTPV1803648	<input type="checkbox"/>	16.0#
	54" 36" 18"	PTPV1803654	<input type="checkbox"/>	14.0#
	66" 36" 30"	PTPV1803666	<input type="checkbox"/>	16.0#
	72" 36" 36"	PTPV1803672	<input type="checkbox"/>	18.0#
	84" 36" 48"	PTPV1803684	<input type="checkbox"/>	17.0#
	48" 42" 6"	PTPV1804248	<input type="checkbox"/>	19.0#
	54" 42" 12"	PTPV1804254	<input type="checkbox"/>	14.0#
	66" 42" 24"	PTPV1804266	<input type="checkbox"/>	16.0#
	72" 42" 30"	PTPV1804272	<input type="checkbox"/>	22.0#
	84" 42" 42"	PTPV1804284	<input type="checkbox"/>	18.0#
	54" 48" 6"	PTPV1804854	<input type="checkbox"/>	10.0#
	66" 48" 18"	PTPV1804866	<input type="checkbox"/>	12.0#
	72" 48" 24"	PTPV1804872	<input type="checkbox"/>	14.0#
	84" 48" 36"	PTPV1804884	<input type="checkbox"/>	16.0#
	66" 54" 12"	PTPV1805466	<input type="checkbox"/>	17.0#
	72" 54" 18"	PTPV1805472	<input type="checkbox"/>	14.0#
	84" 54" 30"	PTPV1805484	<input type="checkbox"/>	19.0#
	72" 66" 6"	PTPV1806672	<input type="checkbox"/>	16.0#
	84" 66" 18"	PTPV1806684	<input type="checkbox"/>	22.0#
	84" 72" 12"	PTPV1807284	<input type="checkbox"/>	18.0#

A

B

HOW TO ORDER

Indicate the following information on order form:

1. Quantity of each item.
2. Model number, including options. See "How To Build a Model Number".
3. Any special service required.

Note: • The indicates that a choice is required.

- The absence of the indicates that no choice is required.
- Alpha-numeric characters in place of indicate that no other alternatives are available.

HOW TO BUILD A MODEL NUMBER

A Select basic model.

B Select trim color.

Refer to the **Product Color Options** page in this catalog.
SX Starlight Silver finish is only offered on flat aluminum trim.

Preconfigured Intersection Conditions

3-Way

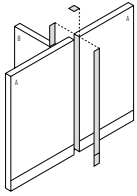
	MODEL	A	B	A-B	MODEL NUMBER			Approx. Packaged Weight
					Basic Model	Trim Color	Fabric Color	
 <p>P1TF - KD1 PTNF - Pass Through</p>	3-Way "T" Intersection w/180° Top Cap, Two Different Heights - ABA	36"	30"	6"	PTPVF1803036	<input type="checkbox"/>	<input type="checkbox"/> <input type="checkbox"/> <input type="checkbox"/> <input type="checkbox"/>	13.0#
		42"	30"	12"	PTPVF1803042	<input type="checkbox"/>	<input type="checkbox"/> <input type="checkbox"/> <input type="checkbox"/> <input type="checkbox"/>	10.0#
	• Upholstered	48"	30"	18"	PTPVF1803048	<input type="checkbox"/>	<input type="checkbox"/> <input type="checkbox"/> <input type="checkbox"/> <input type="checkbox"/>	16.0#
	• 180° top cap	54"	30"	24"	PTPVF1803054	<input type="checkbox"/>	<input type="checkbox"/> <input type="checkbox"/> <input type="checkbox"/> <input type="checkbox"/>	12.0#
	• One fabric-wrapped piece of universal trim	66"	30"	36"	PTPVF1803066	<input type="checkbox"/>	<input type="checkbox"/> <input type="checkbox"/> <input type="checkbox"/> <input type="checkbox"/>	14.0#
	• One fabric-wrapped piece of universal height change trim	72"	30"	42"	PTPVF1803072	<input type="checkbox"/>	<input type="checkbox"/> <input type="checkbox"/> <input type="checkbox"/> <input type="checkbox"/>	23.0#
	• Light block	84"	30"	54"	PTPVF1803084	<input type="checkbox"/>	<input type="checkbox"/> <input type="checkbox"/> <input type="checkbox"/> <input type="checkbox"/>	16.0#
	• 3-way base trim	42"	36"	6"	PTPVF1803642	<input type="checkbox"/>	<input type="checkbox"/> <input type="checkbox"/> <input type="checkbox"/> <input type="checkbox"/>	15.0#
	• Two half-posts (height A)	48"	36"	12"	PTPVF1803648	<input type="checkbox"/>	<input type="checkbox"/> <input type="checkbox"/> <input type="checkbox"/> <input type="checkbox"/>	17.0#
	• One half-post (height B)	54"	36"	18"	PTPVF1803654	<input type="checkbox"/>	<input type="checkbox"/> <input type="checkbox"/> <input type="checkbox"/> <input type="checkbox"/>	19.0#
	• Connecting hardware	66"	36"	30"	PTPVF1803666	<input type="checkbox"/>	<input type="checkbox"/> <input type="checkbox"/> <input type="checkbox"/> <input type="checkbox"/>	22.0#
	• SX Starlight Silver finish is only offered on flat aluminum trim	72"	36"	36"	PTPVF1803672	<input type="checkbox"/>	<input type="checkbox"/> <input type="checkbox"/> <input type="checkbox"/> <input type="checkbox"/>	24.0#
		84"	36"	48"	PTPVF1803684	<input type="checkbox"/>	<input type="checkbox"/> <input type="checkbox"/> <input type="checkbox"/> <input type="checkbox"/>	28.0#
		48"	42"	6"	PTPVF1804248	<input type="checkbox"/>	<input type="checkbox"/> <input type="checkbox"/> <input type="checkbox"/> <input type="checkbox"/>	18.0#
		54"	42"	12"	PTPVF1804254	<input type="checkbox"/>	<input type="checkbox"/> <input type="checkbox"/> <input type="checkbox"/> <input type="checkbox"/>	14.0#
		66"	42"	24"	PTPVF1804266	<input type="checkbox"/>	<input type="checkbox"/> <input type="checkbox"/> <input type="checkbox"/> <input type="checkbox"/>	16.0#
		72"	42"	30"	PTPVF1804272	<input type="checkbox"/>	<input type="checkbox"/> <input type="checkbox"/> <input type="checkbox"/> <input type="checkbox"/>	25.0#
		84"	42"	42"	PTPVF1804284	<input type="checkbox"/>	<input type="checkbox"/> <input type="checkbox"/> <input type="checkbox"/> <input type="checkbox"/>	18.0#
		54"	48"	6"	PTPVF1804854	<input type="checkbox"/>	<input type="checkbox"/> <input type="checkbox"/> <input type="checkbox"/> <input type="checkbox"/>	20.0#
		66"	48"	18"	PTPVF1804866	<input type="checkbox"/>	<input type="checkbox"/> <input type="checkbox"/> <input type="checkbox"/> <input type="checkbox"/>	23.0#
		72"	48"	24"	PTPVF1804872	<input type="checkbox"/>	<input type="checkbox"/> <input type="checkbox"/> <input type="checkbox"/> <input type="checkbox"/>	26.0#
		84"	48"	36"	PTPVF1804884	<input type="checkbox"/>	<input type="checkbox"/> <input type="checkbox"/> <input type="checkbox"/> <input type="checkbox"/>	29.0#
		66"	54"	12"	PTPVF1805466	<input type="checkbox"/>	<input type="checkbox"/> <input type="checkbox"/> <input type="checkbox"/> <input type="checkbox"/>	17.0#
		72"	54"	18"	PTPVF1805472	<input type="checkbox"/>	<input type="checkbox"/> <input type="checkbox"/> <input type="checkbox"/> <input type="checkbox"/>	10.0#
		84"	54"	30"	PTPVF1805484	<input type="checkbox"/>	<input type="checkbox"/> <input type="checkbox"/> <input type="checkbox"/> <input type="checkbox"/>	19.0#
		72"	66"	6"	PTPVF1806672	<input type="checkbox"/>	<input type="checkbox"/> <input type="checkbox"/> <input type="checkbox"/> <input type="checkbox"/>	27.0#
		84"	66"	18"	PTPVF1806684	<input type="checkbox"/>	<input type="checkbox"/> <input type="checkbox"/> <input type="checkbox"/> <input type="checkbox"/>	22.0#
		84"	72"	12"	PTPVF1807284	<input type="checkbox"/>	<input type="checkbox"/> <input type="checkbox"/> <input type="checkbox"/> <input type="checkbox"/>	30.0#

A

B

C

HOW TO ORDER

Indicate the following information on order form:

- Quantity of each item.
- Model number, including options. See "How To Build a Model Number".
- Any special service required.

Note: • The indicates that a choice is required.

- The absence of the indicates that no choice is required.
- Alpha-numeric characters in place of indicate that no other alternatives are available.

HOW TO BUILD A MODEL NUMBER

- A** Select basic model.
- B** Select trim color.
Refer to the **Product Color Options** page in this catalog.
SX Starlight Silver finish is only offered on flat aluminum trim.
- C** Select fabric color.

Preconfigured Intersection Conditions

4-Way

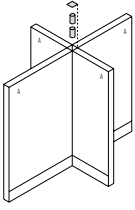
MODEL	A	MODEL NUMBER			Approx. Packaged Weight
		Basic Model	Assembly	Trim Color	
 <p>P1TN - KD1 PTN - Pass Through</p> <p>4-Way "X" Intersection with 4-Way Top Cap, All Panels Same Height</p> <ul style="list-style-type: none"> • Unupholstered: trim colored • 4-way top cap • 4-way light block • Four half-posts • Connecting hardware • SX Starlight Silver finish is only offered on flat aluminum trim 	30"	PXP4W30	<input type="checkbox"/>	<input type="checkbox"/>	10.0#
	36"	PXP4W36	<input type="checkbox"/>	<input type="checkbox"/>	10.0#
	42"	PXP4W42	<input type="checkbox"/>	<input type="checkbox"/>	14.0#
	48"	PXP4W48	<input type="checkbox"/>	<input type="checkbox"/>	14.0#
	54"	PXP4W54	<input type="checkbox"/>	<input type="checkbox"/>	19.0#
	60"	PXP4W60	<input type="checkbox"/>	<input type="checkbox"/>	19.0#
	66"	PXP4W66	<input type="checkbox"/>	<input type="checkbox"/>	23.0#
	72"	PXP4W72	<input type="checkbox"/>	<input type="checkbox"/>	23.0#
	78"	PXP4W78	<input type="checkbox"/>	<input type="checkbox"/>	26.0#
	84"	PXP4W84	<input type="checkbox"/>	<input type="checkbox"/>	30.0#

A

B

C

HOW TO ORDER

Indicate the following information on order form:

1. Quantity of each item.
2. Model number, including options. See "How To Build a Model Number".
3. Any special service required.

Note: • The indicates that a choice is required.

- The absence of the indicates that no choice is required.
- Alpha-numeric characters in place of indicate that no other alternatives are available.

HOW TO BUILD A MODEL NUMBER

A Select basic model.

B Select assembly.

F	- Fully Assembled
U	- Unassembled

C Select trim color.

Refer to the **Product Color Options** page in this catalog.
SX Starlight Silver finish is only offered on flat aluminum trim.

Preconfigured Intersection Conditions

4-Way

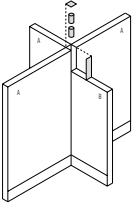
	MODEL	A	B	A-B	MODEL NUMBER		Approx. Packaged Weight
					Basic Model	Trim Color	
 <p>P1TN - KD1 PTN - Pass Through</p>	4-Way "X" Intersection with 3-Way Top Cap, Two Different Heights - AAAB	36"	30"	6"	PXPV3W3036	<input type="checkbox"/>	13.0#
	• Unupholstered: trim colored	42"	30"	12"	PXPV3W3042	<input type="checkbox"/>	14.0#
	• 3-way top cap	48"	30"	18"	PXPV3W3048	<input type="checkbox"/>	17.0#
	• 4-way light block	54"	30"	24"	PXPV3W3054	<input type="checkbox"/>	17.0#
	• One piece of universal height change trim	66"	30"	36"	PXPV3W3066	<input type="checkbox"/>	20.0#
	• One half-post (height B)	72"	30"	42"	PXPV3W3072	<input type="checkbox"/>	23.0#
	• Three half-posts (height A)	84"	30"	54"	PXPV3W3084	<input type="checkbox"/>	26.0#
	• Connecting hardware	42"	36"	6"	PXPV3W3642	<input type="checkbox"/>	16.0#
	• SX Starlight Silver finish is only offered on flat aluminum trim	48"	36"	12"	PXPV3W3648	<input type="checkbox"/>	17.0#
		54"	36"	18"	PXPV3W3654	<input type="checkbox"/>	19.0#
		66"	36"	30"	PXPV3W3666	<input type="checkbox"/>	21.0#
		72"	36"	36"	PXPV3W3672	<input type="checkbox"/>	23.0#
		84"	36"	48"	PXPV3W3684	<input type="checkbox"/>	26.0#
		48"	42"	6"	PXPV3W4248	<input type="checkbox"/>	18.0#
		54"	42"	12"	PXPV3W4254	<input type="checkbox"/>	18.0#
		66"	42"	24"	PXPV3W4266	<input type="checkbox"/>	21.0#
		72"	42"	30"	PXPV3W4272	<input type="checkbox"/>	24.0#
		84"	42"	42"	PXPV3W4284	<input type="checkbox"/>	27.0#
		54"	48"	6"	PXPV3W4854	<input type="checkbox"/>	20.0#
		66"	48"	18"	PXPV3W4866	<input type="checkbox"/>	23.0#
		72"	48"	24"	PXPV3W4872	<input type="checkbox"/>	25.0#
		84"	48"	36"	PXPV3W4884	<input type="checkbox"/>	27.0#
		66"	54"	12"	PXPV3W5466	<input type="checkbox"/>	22.0#
		72"	54"	18"	PXPV3W5472	<input type="checkbox"/>	26.0#
		84"	54"	30"	PXPV3W5484	<input type="checkbox"/>	28.0#
		72"	66"	6"	PXPV3W6672	<input type="checkbox"/>	27.0#
		84"	66"	18"	PXPV3W6684	<input type="checkbox"/>	29.0#
		84"	72"	12"	PXPV3W7284	<input type="checkbox"/>	30.0#

A

B

HOW TO ORDER

Indicate the following information on order form:

- Quantity of each item.
- Model number, including options. See "How To Build a Model Number".
- Any special service required.

Note: • The indicates that a choice is required.

- The absence of the indicates that no choice is required.
- Alpha-numeric characters in place of indicate that no other alternatives are available.

HOW TO BUILD A MODEL NUMBER

A Select basic model.

B Select trim color.

Refer to the **Product Color Options** page in this catalog.

SX Starlight Silver finish is only offered on flat aluminum trim.

Preconfigured Intersection Conditions

4-Way

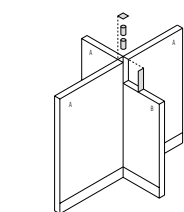

P1TF - KD1

PTF - Pass Through

MODEL

A B A-B

MODEL NUMBER

Basic Model

Trim Color

Fabric Color

Approx. Packaged Weight

4-Way "X" Intersection with 3-Way Top Cap, Two Different Heights - AAAB

- Upholstered
- 3-way top cap
- 4-way light block
- One fabric-wrapped piece of universal height change trim
- One half-post (height B)
- Three half-posts (height A)
- Connecting hardware
- SX Starlight Silver finish is only offered on flat aluminum trim

MODEL	A	B	A-B	Basic Model	Trim Color	Fabric Color	Approx. Packaged Weight
	36"	30"	6"	PXPVF3W3036	<input type="checkbox"/>	<input type="checkbox"/> <input type="checkbox"/> <input type="checkbox"/> <input type="checkbox"/>	13.0#
	42"	30"	12"	PXPVF3W3042	<input type="checkbox"/>	<input type="checkbox"/> <input type="checkbox"/> <input type="checkbox"/> <input type="checkbox"/>	14.0#
	48"	30"	18"	PXPVF3W3048	<input type="checkbox"/>	<input type="checkbox"/> <input type="checkbox"/> <input type="checkbox"/> <input type="checkbox"/>	17.0#
	54"	30"	24"	PXPVF3W3054	<input type="checkbox"/>	<input type="checkbox"/> <input type="checkbox"/> <input type="checkbox"/> <input type="checkbox"/>	17.0#
	66"	30"	36"	PXPVF3W3066	<input type="checkbox"/>	<input type="checkbox"/> <input type="checkbox"/> <input type="checkbox"/> <input type="checkbox"/>	20.0#
	72"	30"	42"	PXPVF3W3072	<input type="checkbox"/>	<input type="checkbox"/> <input type="checkbox"/> <input type="checkbox"/> <input type="checkbox"/>	23.0#
	84"	30"	54"	PXPVF3W3084	<input type="checkbox"/>	<input type="checkbox"/> <input type="checkbox"/> <input type="checkbox"/> <input type="checkbox"/>	26.0#
	42"	36"	6"	PXPVF3W3642	<input type="checkbox"/>	<input type="checkbox"/> <input type="checkbox"/> <input type="checkbox"/> <input type="checkbox"/>	16.0#
	48"	36"	12"	PXPVF3W3648	<input type="checkbox"/>	<input type="checkbox"/> <input type="checkbox"/> <input type="checkbox"/> <input type="checkbox"/>	17.0#
	54"	36"	18"	PXPVF3W3654	<input type="checkbox"/>	<input type="checkbox"/> <input type="checkbox"/> <input type="checkbox"/> <input type="checkbox"/>	19.0#
	66"	36"	30"	PXPVF3W3666	<input type="checkbox"/>	<input type="checkbox"/> <input type="checkbox"/> <input type="checkbox"/> <input type="checkbox"/>	21.0#
	72"	36"	36"	PXPVF3W3672	<input type="checkbox"/>	<input type="checkbox"/> <input type="checkbox"/> <input type="checkbox"/> <input type="checkbox"/>	23.0#
	84"	36"	48"	PXPVF3W3684	<input type="checkbox"/>	<input type="checkbox"/> <input type="checkbox"/> <input type="checkbox"/> <input type="checkbox"/>	26.0#
	48"	42"	6"	PXPVF3W4248	<input type="checkbox"/>	<input type="checkbox"/> <input type="checkbox"/> <input type="checkbox"/> <input type="checkbox"/>	18.0#
	54"	42"	12"	PXPVF3W4254	<input type="checkbox"/>	<input type="checkbox"/> <input type="checkbox"/> <input type="checkbox"/> <input type="checkbox"/>	18.0#
	66"	42"	24"	PXPVF3W4266	<input type="checkbox"/>	<input type="checkbox"/> <input type="checkbox"/> <input type="checkbox"/> <input type="checkbox"/>	21.0#
	72"	42"	30"	PXPVF3W4272	<input type="checkbox"/>	<input type="checkbox"/> <input type="checkbox"/> <input type="checkbox"/> <input type="checkbox"/>	24.0#
	84"	42"	42"	PXPVF3W4284	<input type="checkbox"/>	<input type="checkbox"/> <input type="checkbox"/> <input type="checkbox"/> <input type="checkbox"/>	27.0#
	54"	48"	6"	PXPVF3W4854	<input type="checkbox"/>	<input type="checkbox"/> <input type="checkbox"/> <input type="checkbox"/> <input type="checkbox"/>	20.0#
	66"	48"	18"	PXPVF3W4866	<input type="checkbox"/>	<input type="checkbox"/> <input type="checkbox"/> <input type="checkbox"/> <input type="checkbox"/>	23.0#
	72"	48"	24"	PXPVF3W4872	<input type="checkbox"/>	<input type="checkbox"/> <input type="checkbox"/> <input type="checkbox"/> <input type="checkbox"/>	25.0#
	84"	48"	36"	PXPVF3W4884	<input type="checkbox"/>	<input type="checkbox"/> <input type="checkbox"/> <input type="checkbox"/> <input type="checkbox"/>	27.0#
	66"	54"	12"	PXPVF3W5466	<input type="checkbox"/>	<input type="checkbox"/> <input type="checkbox"/> <input type="checkbox"/> <input type="checkbox"/>	22.0#
	72"	54"	18"	PXPVF3W5472	<input type="checkbox"/>	<input type="checkbox"/> <input type="checkbox"/> <input type="checkbox"/> <input type="checkbox"/>	26.0#
	84"	54"	30"	PXPVF3W5484	<input type="checkbox"/>	<input type="checkbox"/> <input type="checkbox"/> <input type="checkbox"/> <input type="checkbox"/>	28.0#
	72"	66"	6"	PXPVF3W6672	<input type="checkbox"/>	<input type="checkbox"/> <input type="checkbox"/> <input type="checkbox"/> <input type="checkbox"/>	27.0#
	84"	66"	18"	PXPVF3W6684	<input type="checkbox"/>	<input type="checkbox"/> <input type="checkbox"/> <input type="checkbox"/> <input type="checkbox"/>	29.0#
	84"	72"	12"	PXPVF3W7284	<input type="checkbox"/>	<input type="checkbox"/> <input type="checkbox"/> <input type="checkbox"/> <input type="checkbox"/>	30.0#

A

B

C

HOW TO ORDER

Indicate the following information on order form:

1. Quantity of each item.
2. Model number, including options. See "How To Build a Model Number".
3. Any special service required.

Note: • The indicates that a choice is required.

- The absence of the indicates that no choice is required.
- Alpha-numeric characters in place of indicate that no other alternatives are available.

HOW TO BUILD A MODEL NUMBER

A Select basic model.

B Select trim color.
Refer to the **Product Color Options** page in this catalog.
SX Starlight Silver finish is only offered on flat aluminum trim.

C Select fabric color.

Preconfigured Intersection Conditions

4-Way

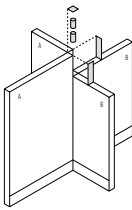
MODEL	A B A-B	MODEL NUMBER		Approx. Packaged Weight
		Basic Model	Trim Color	
 <p>P1TN - KD1 PTN - Pass Through</p> <p>4-Way "X" Intersection w/90° Top Cap, Two Different Heights - AABB</p> <ul style="list-style-type: none"> • Unupholstered: trim colored • 90° top cap • 4-way light block • Two pieces of universal height change trim • Two half-posts (height A) • Two half-posts (height B) • Connecting hardware • SX Starlight Silver finish is only offered on flat aluminum trim 	36" 30" 6"	PXPV903036	<input type="checkbox"/>	13.0#
	42" 30" 12"	PXPV903042	<input type="checkbox"/>	13.0#
	48" 30" 18"	PXPV903048	<input type="checkbox"/>	17.0#
	54" 30" 24"	PXPV903054	<input type="checkbox"/>	16.0#
	66" 30" 36"	PXPV903066	<input type="checkbox"/>	19.0#
	72" 30" 42"	PXPV903072	<input type="checkbox"/>	24.0#
	84" 30" 54"	PXPV903084	<input type="checkbox"/>	23.0#
	42" 36" 6"	PXPV903642	<input type="checkbox"/>	16.0#
	48" 36" 12"	PXPV903648	<input type="checkbox"/>	17.0#
	54" 36" 18"	PXPV903654	<input type="checkbox"/>	19.0#
	66" 36" 30"	PXPV903666	<input type="checkbox"/>	22.0#
	72" 36" 36"	PXPV903672	<input type="checkbox"/>	24.0#
	84" 36" 48"	PXPV903684	<input type="checkbox"/>	27.0#
	48" 42" 6"	PXPV904248	<input type="checkbox"/>	18.0#
	54" 42" 12"	PXPV904254	<input type="checkbox"/>	17.0#
	66" 42" 24"	PXPV904266	<input type="checkbox"/>	20.0#
	72" 42" 30"	PXPV904272	<input type="checkbox"/>	25.0#
	84" 42" 42"	PXPV904284	<input type="checkbox"/>	24.0#
	54" 48" 6"	PXPV904854	<input type="checkbox"/>	20.0#
	66" 48" 18"	PXPV904866	<input type="checkbox"/>	23.0#
	72" 48" 24"	PXPV904872	<input type="checkbox"/>	25.0#
	84" 48" 36"	PXPV904884	<input type="checkbox"/>	28.0#
	66" 54" 12"	PXPV905466	<input type="checkbox"/>	21.0#
	72" 54" 18"	PXPV905472	<input type="checkbox"/>	26.0#
	84" 54" 30"	PXPV905484	<input type="checkbox"/>	25.0#
	72" 66" 6"	PXPV906672	<input type="checkbox"/>	27.0#
	84" 66" 18"	PXPV906684	<input type="checkbox"/>	27.0#
	84" 72" 12"	PXPV907284	<input type="checkbox"/>	30.0#

A

B

HOW TO ORDER

Indicate the following information on order form:

1. Quantity of each item.
2. Model number, including options. See "How To Build a Model Number".
3. Any special service required.

Note: • The indicates that a choice is required.

- The absence of the indicates that no choice is required.
- Alpha-numeric characters in place of indicate that no other alternatives are available.

HOW TO BUILD A MODEL NUMBER

A Select basic model.

B Select trim color.

Refer to the **Product Color Options** page in this catalog.

SX Starlight Silver finish is only offered on flat aluminum trim.

Preconfigured Intersection Conditions

4-Way

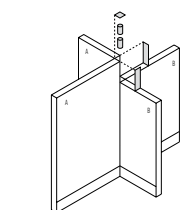

P1TF - KD1

PTNF - Pass Through

MODEL

A B A-B

MODEL NUMBER

Basic Model

Trim Color

Fabric Color

Approx. Packaged Weight

4-Way "X" Intersection w/90° Top Cap, Two Different Heights - AABB

- Upholstered
- 90° top cap
- 4-way light block
- Two fabric-wrapped pieces of universal height change trim
- Two half-posts (height A)
- Two half-posts (height B)
- Connecting hardware
- SX Starlight Silver finish is only offered on flat aluminum trim

MODEL	A B A-B	Basic Model	Trim Color	Fabric Color	Approx. Packaged Weight
4-Way "X" Intersection w/90° Top Cap, Two Different Heights - AABB	36" 30" 6"	PXPVF903036	<input type="checkbox"/>	<input type="checkbox"/>	13.0#
	42" 30" 12"	PXPVF903042	<input type="checkbox"/>	<input type="checkbox"/>	13.0#
	48" 30" 18"	PXPVF903048	<input type="checkbox"/>	<input type="checkbox"/>	17.0#
	54" 30" 24"	PXPVF903054	<input type="checkbox"/>	<input type="checkbox"/>	16.0#
	66" 30" 36"	PXPVF903066	<input type="checkbox"/>	<input type="checkbox"/>	19.0#
	72" 30" 42"	PXPVF903072	<input type="checkbox"/>	<input type="checkbox"/>	24.0#
	84" 30" 54"	PXPVF903084	<input type="checkbox"/>	<input type="checkbox"/>	23.0#
	42" 36" 6"	PXPVF903642	<input type="checkbox"/>	<input type="checkbox"/>	16.0#
	48" 36" 12"	PXPVF903648	<input type="checkbox"/>	<input type="checkbox"/>	17.0#
	54" 36" 18"	PXPVF903654	<input type="checkbox"/>	<input type="checkbox"/>	19.0#
	66" 36" 30"	PXPVF903666	<input type="checkbox"/>	<input type="checkbox"/>	22.0#
	72" 36" 36"	PXPVF903672	<input type="checkbox"/>	<input type="checkbox"/>	24.0#
	84" 36" 48"	PXPVF903684	<input type="checkbox"/>	<input type="checkbox"/>	27.0#
	48" 42" 6"	PXPVF904248	<input type="checkbox"/>	<input type="checkbox"/>	18.0#
	54" 42" 12"	PXPVF904254	<input type="checkbox"/>	<input type="checkbox"/>	17.0#
	66" 42" 24"	PXPVF904266	<input type="checkbox"/>	<input type="checkbox"/>	20.0#
	72" 42" 30"	PXPVF904272	<input type="checkbox"/>	<input type="checkbox"/>	25.0#
	84" 42" 42"	PXPVF904284	<input type="checkbox"/>	<input type="checkbox"/>	24.0#
	54" 48" 6"	PXPVF904854	<input type="checkbox"/>	<input type="checkbox"/>	20.0#
	66" 48" 18"	PXPVF904866	<input type="checkbox"/>	<input type="checkbox"/>	23.0#
	72" 48" 24"	PXPVF904872	<input type="checkbox"/>	<input type="checkbox"/>	25.0#
	84" 48" 36"	PXPVF904884	<input type="checkbox"/>	<input type="checkbox"/>	28.0#
	66" 54" 12"	PXPVF905466	<input type="checkbox"/>	<input type="checkbox"/>	21.0#
	72" 54" 18"	PXPVF905472	<input type="checkbox"/>	<input type="checkbox"/>	26.0#
	84" 54" 30"	PXPVF905484	<input type="checkbox"/>	<input type="checkbox"/>	25.0#
	72" 66" 6"	PXPVF906672	<input type="checkbox"/>	<input type="checkbox"/>	27.0#
	84" 66" 18"	PXPVF906684	<input type="checkbox"/>	<input type="checkbox"/>	27.0#
	84" 72" 12"	PXPVF907284	<input type="checkbox"/>	<input type="checkbox"/>	30.0#

A

B

C

HOW TO ORDER

Indicate the following information on order form:

1. Quantity of each item.
2. Model number, including options. See "How To Build a Model Number".
3. Any special service required.

Note: • The indicates that a choice is required.

- The absence of the indicates that no choice is required.
- Alpha-numeric characters in place of indicate that no other alternatives are available.

HOW TO BUILD A MODEL NUMBER

A Select basic model.

B Select trim color.
Refer to the **Product Color Options** page in this catalog.
SX Starlight Silver finish is only offered on flat aluminum trim.

C Select fabric color.

Preconfigured Intersection Conditions

4-Way

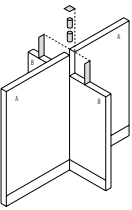
MODEL	A B A-B	MODEL NUMBER		Approx. Packaged Weight
		Basic Model	Trim Color	
 <p>P1TN - KD1 PTN - Pass Through</p> <p>4-Way "X" Intersection w/180° Top Cap, Two Different Heights - ABAB</p> <ul style="list-style-type: none"> • Upholstered: trim colored • 180° top cap • 4-way light block • Two pieces of universal height change trim • Two half-posts (height B) • Two half-posts (height A) • Connecting hardware • SX Starlight Silver finish is only offered on flat aluminum trim 	36" 30" 6"	PXPV1803036	<input type="checkbox"/>	13.0#
	42" 30" 12"	PXPV1803042	<input type="checkbox"/>	13.0#
	48" 30" 18"	PXPV1803048	<input type="checkbox"/>	17.0#
	54" 30" 24"	PXPV1803054	<input type="checkbox"/>	16.0#
	66" 30" 36"	PXPV1803066	<input type="checkbox"/>	19.0#
	72" 30" 42"	PXPV1803072	<input type="checkbox"/>	22.0#
	84" 30" 54"	PXPV1803084	<input type="checkbox"/>	23.0#
	42" 36" 6"	PXPV1803642	<input type="checkbox"/>	16.0#
	48" 36" 12"	PXPV1803648	<input type="checkbox"/>	17.0#
	54" 36" 18"	PXPV1803654	<input type="checkbox"/>	19.0#
	66" 36" 30"	PXPV1803666	<input type="checkbox"/>	21.0#
	72" 36" 36"	PXPV1803672	<input type="checkbox"/>	23.0#
	84" 36" 48"	PXPV1803684	<input type="checkbox"/>	26.0#
	48" 42" 6"	PXPV1804248	<input type="checkbox"/>	18.0#
	54" 42" 12"	PXPV1804254	<input type="checkbox"/>	17.0#
	66" 42" 24"	PXPV1804266	<input type="checkbox"/>	20.0#
	72" 42" 30"	PXPV1804272	<input type="checkbox"/>	24.0#
	84" 42" 42"	PXPV1804284	<input type="checkbox"/>	25.0#
	54" 48" 6"	PXPV1804854	<input type="checkbox"/>	20.0#
	66" 48" 18"	PXPV1804866	<input type="checkbox"/>	23.0#
	72" 48" 24"	PXPV1804872	<input type="checkbox"/>	25.0#
	84" 48" 36"	PXPV1804884	<input type="checkbox"/>	27.0#
	66" 54" 12"	PXPV1805466	<input type="checkbox"/>	21.0#
	72" 54" 18"	PXPV1805472	<input type="checkbox"/>	25.0#
	84" 54" 30"	PXPV1805484	<input type="checkbox"/>	26.0#
	72" 66" 6"	PXPV1806672	<input type="checkbox"/>	26.0#
	84" 66" 18"	PXPV1806684	<input type="checkbox"/>	27.0#
	84" 72" 12"	PXPV1807284	<input type="checkbox"/>	30.0#

A

B

HOW TO ORDER

Indicate the following information on order form:

1. Quantity of each item.
2. Model number, including options. See "How To Build a Model Number".
3. Any special service required.

Note: • The indicates that a choice is required.

- The absence of the indicates that no choice is required.
- Alpha-numeric characters in place of indicate that no other alternatives are available.

HOW TO BUILD A MODEL NUMBER

A Select basic model.

B Select trim color.

Refer to the **Product Color Options** page in this catalog.

SX Starlight Silver finish is only offered on flat aluminum trim.

Preconfigured Intersection Conditions

4-Way

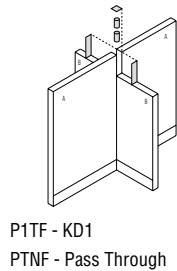

MODEL

A B A-B

MODEL NUMBER

Basic Model

Trim Color

Fabric Color

Approx. Packaged Weight

4-Way "X" Intersection w/180° Top Cap, Two Different Heights - AABB

- Upholstered
- 180° top cap
- 4-way light block
- Two fabric-wrapped pieces of universal height change trim
- Two half-posts (height A)
- Two half-posts (height B)
- Connecting hardware
- SX Starlight Silver finish is only offered on flat aluminum trim

MODEL	A B A-B	Basic Model	Trim Color	Fabric Color	Approx. Packaged Weight
	36" 30" 6"	PXPVVF1803036	<input type="checkbox"/>	<input type="checkbox"/>	13.0#
	42" 30" 12"	PXPVVF1803042	<input type="checkbox"/>	<input type="checkbox"/>	13.0#
	48" 30" 18"	PXPVVF1803048	<input type="checkbox"/>	<input type="checkbox"/>	17.0#
	54" 30" 24"	PXPVVF1803054	<input type="checkbox"/>	<input type="checkbox"/>	16.0#
	66" 30" 36"	PXPVVF1803066	<input type="checkbox"/>	<input type="checkbox"/>	19.0#
	72" 30" 42"	PXPVVF1803072	<input type="checkbox"/>	<input type="checkbox"/>	22.0#
	84" 30" 54"	PXPVVF1803084	<input type="checkbox"/>	<input type="checkbox"/>	23.0#
	42" 36" 6"	PXPVVF1803642	<input type="checkbox"/>	<input type="checkbox"/>	16.0#
	48" 36" 12"	PXPVVF1803648	<input type="checkbox"/>	<input type="checkbox"/>	17.0#
	54" 36" 18"	PXPVVF1803654	<input type="checkbox"/>	<input type="checkbox"/>	19.0#
	66" 36" 30"	PXPVVF1803666	<input type="checkbox"/>	<input type="checkbox"/>	21.0#
	72" 36" 36"	PXPVVF1803672	<input type="checkbox"/>	<input type="checkbox"/>	23.0#
	84" 36" 48"	PXPVVF1803684	<input type="checkbox"/>	<input type="checkbox"/>	26.0#
	48" 42" 6"	PXPVVF1804248	<input type="checkbox"/>	<input type="checkbox"/>	18.0#
	54" 42" 12"	PXPVVF1804254	<input type="checkbox"/>	<input type="checkbox"/>	17.0#
	66" 42" 24"	PXPVVF1804266	<input type="checkbox"/>	<input type="checkbox"/>	20.0#
	72" 42" 30"	PXPVVF1804272	<input type="checkbox"/>	<input type="checkbox"/>	24.0#
	84" 42" 42"	PXPVVF1804284	<input type="checkbox"/>	<input type="checkbox"/>	25.0#
	54" 48" 6"	PXPVVF1804854	<input type="checkbox"/>	<input type="checkbox"/>	20.0#
	66" 48" 18"	PXPVVF1804866	<input type="checkbox"/>	<input type="checkbox"/>	23.0#
	72" 48" 24"	PXPVVF1804872	<input type="checkbox"/>	<input type="checkbox"/>	25.0#
	84" 48" 36"	PXPVVF1804884	<input type="checkbox"/>	<input type="checkbox"/>	27.0#
	66" 54" 12"	PXPVVF1805466	<input type="checkbox"/>	<input type="checkbox"/>	21.0#
	72" 54" 18"	PXPVVF1805472	<input type="checkbox"/>	<input type="checkbox"/>	25.0#
	84" 54" 30"	PXPVVF1805484	<input type="checkbox"/>	<input type="checkbox"/>	26.0#
	72" 66" 6"	PXPVVF1806672	<input type="checkbox"/>	<input type="checkbox"/>	26.0#
	84" 66" 18"	PXPVVF1806684	<input type="checkbox"/>	<input type="checkbox"/>	27.0#
	84" 72" 12"	PXPVVF1807284	<input type="checkbox"/>	<input type="checkbox"/>	30.0#

A

B

C

HOW TO ORDER

Indicate the following information on order form:

1. Quantity of each item.
2. Model number, including options. See "How To Build a Model Number".
3. Any special service required.

Note: • The indicates that a choice is required.

- The absence of the indicates that no choice is required.
- Alpha-numeric characters in place of indicate that no other alternatives are available.

HOW TO BUILD A MODEL NUMBER

A Select basic model.

B Select trim color.
Refer to the **Product Color Options** page in this catalog.
SX Starlight Silver finish is only offered on flat aluminum trim.

C Select fabric color.

Preconfigured Stackable Intersection Conditions

180° 2-Way and End-of-Run

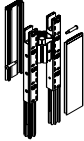
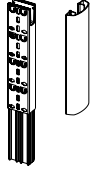
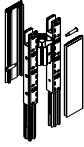
	MODEL	H	MODEL NUMBER			Approx. Packaged Weight
			Basic Model	Trim Color	Fabric Color	
 <p>Stackable Panel-180° 2-Way In-Line Connection, Both Same Height</p> <ul style="list-style-type: none"> • Unupholstered • One stackable full-post • Black only 		12"	PSFP12			3.0#
		18"	PSFP18			4.0#
		24"	PSFP24			5.0#
PST						
 <p>Stackable Panel-180° 2-Way In-Line Spacer, Both Same Height</p> <ul style="list-style-type: none"> • Unupholstered: trim colored • Two pieces of stackable universal trim • Stackable in-line trim • Two stackable half-posts • Corner connector block • Use top caps from existing lower panels • SX Starlight Silver finish is only offered on flat aluminum trim 		12"	PSSP18012	<input type="checkbox"/>		3.0#
		18"	PSSP18018	<input type="checkbox"/>		4.0#
		24"	PSSP18024	<input type="checkbox"/>		5.0#
PST						
 <p>Stackable Panel - End-Of-Run Condition</p> <ul style="list-style-type: none"> • Unupholstered • Stackable end-of-run trim • Stackable full-post • SX Starlight Silver finish is only offered on flat aluminum trim 		12"	PSEP12	<input type="checkbox"/>		2.0#
		18"	PSEP18	<input type="checkbox"/>		2.0#
		24"	PSEP24	<input type="checkbox"/>		3.0#
PST						
 <p>Stackable Panel-180° 2-Way In-Line Spacer, Both Panels Same Height</p> <ul style="list-style-type: none"> • Upholstered • Two pieces of fabric-wrapped universal trim • Two stackable half-posts • Corner connector block • Use top caps from existing lower panels 		12"	PSSPF18012		<input type="checkbox"/> <input type="checkbox"/> <input type="checkbox"/> <input type="checkbox"/>	3.0#
		18"	PSSPF18018		<input type="checkbox"/> <input type="checkbox"/> <input type="checkbox"/> <input type="checkbox"/>	4.0#
		24"	PSSPF18024		<input type="checkbox"/> <input type="checkbox"/> <input type="checkbox"/> <input type="checkbox"/>	5.0#
P1STF - KD1 PSTF - Pass Through						

A **B** **C**

HOW TO ORDER

Indicate the following information on order form:

1. Quantity of each item.
2. Model number, including options. See "How To Build a Model Number".
3. Any special service required.

Note: • The indicates that a choice is required.



- The absence of the indicates that no choice is required.
- Alpha-numeric characters in place of indicate that no other alternatives are available.

HOW TO BUILD A MODEL NUMBER

- A** Select basic model.
- B** Select trim color.
Refer to the **Product Color Options** page in this catalog.
SX Starlight Silver finish is only offered on flat aluminum trim.
- C** Select fabric color.

Preconfigured Stackable Intersection Conditions

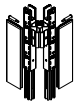
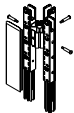
2-Way and 3-Way

	MODEL	H	MODEL NUMBER		Approx. Packaged Weight
			Basic Model	Trim Color	
 PST	Stackable Panel-90° 2-Way "L" Corner, Both Panels Same Height <ul style="list-style-type: none"> • Unupholstered • Two pieces of stackable universal trim • Two stackable full-posts • Corner connector block • Use top caps from existing lower panels • SX Starlight Silver finish is only offered on flat aluminum trim 	12"	PSCP9012	<input type="checkbox"/>	3.0#
		18"	PSCP9018	<input type="checkbox"/>	4.0#
		24"	PSCP9024	<input type="checkbox"/>	5.0#
 PST	Stackable Panel - 3-Way "T" Intersection/3-Way, All Panels Same Height <ul style="list-style-type: none"> • Unupholstered • Stackable universal trim • Three stackable half-posts • Corner connector block • Use top caps from existing lower panels • SX Starlight Silver finish is only offered on flat aluminum trim 	12"	PSTP3W12	<input type="checkbox"/>	4.0#
		18"	PSTP3W18	<input type="checkbox"/>	5.0#
		24"	PSTP3W24	<input type="checkbox"/>	7.0#
 HRDPT	Stackable/Adjustable Wall Mount <ul style="list-style-type: none"> • Unupholstered • Attaches a stackable panel to a wall at the start of a run • Includes mounting plate and half-post • Steel construction with painted finish • Hardware for wall attachment is not included • Adjustable up to 1" to correct wall deflection 	12"	PSWM12		5.0#
		18"	PSWM18		7.0#
		24"	PSWM24		9.0#

A

B

HOW TO ORDER

Indicate the following information on order form:

1. Quantity of each item.
2. Model number, including options. See "How To Build a Model Number".
3. Any special service required.

Note: • The indicates that a choice is required.

- The absence of the indicates that no choice is required.
- Alpha-numeric characters in place of indicate that no other alternatives are available.



HOW TO BUILD A MODEL NUMBER

A Select basic model.

B Select trim color.
Refer to the **Product Color Options** page in this catalog.
SX Starlight Silver finish is only offered on flat aluminum trim.

Preconfigured Stackable Intersection Conditions

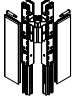
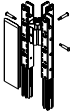
2-Way, 3-Way and 4-Way

	MODEL	H	MODEL NUMBER		Approx. Packaged Weight
			Basic Model	Fabric Color	
 P1STF - KD1 PSTF - Pass Through	Stackable Panel-90° 2-way "L" Corner, Both Panels Same Height <ul style="list-style-type: none"> Upholstered Two pieces of stackable universal trim Two stackable half-posts Corner connector block Use top caps from existing lower panels 	12"	PSCPF9012	<input type="checkbox"/> <input type="checkbox"/> <input type="checkbox"/> <input type="checkbox"/>	3.0#
		18"	PSCPF9018	<input type="checkbox"/> <input type="checkbox"/> <input type="checkbox"/> <input type="checkbox"/>	4.0#
		24"	PSCPF9024	<input type="checkbox"/> <input type="checkbox"/> <input type="checkbox"/> <input type="checkbox"/>	5.0#
 P1STF - KD1 PSTF - Pass Through	Stackable Panel - 3-Way "T" Intersection/3-Way, All Panels Same Height <ul style="list-style-type: none"> Upholstered Fabric-wrapped stackable universal trim Three stackable half-posts Corner connector block Use top caps from existing lower panels 	12"	PSTPF3W12	<input type="checkbox"/> <input type="checkbox"/> <input type="checkbox"/> <input type="checkbox"/>	4.0#
		18"	PSTPF3W18	<input type="checkbox"/> <input type="checkbox"/> <input type="checkbox"/> <input type="checkbox"/>	5.0#
		24"	PSTPF3W24	<input type="checkbox"/> <input type="checkbox"/> <input type="checkbox"/> <input type="checkbox"/>	7.0#
 PST	Stackable Panel-4Way "X" Intersection/ 4-Way Top Cap, All Same Height <ul style="list-style-type: none"> Unupholstered Four stackable half-posts Corner connector block 4-way light block Use top caps from existing lower panels 	12"	PSXP4W12		5.0#
		18"	PSXP4W18		7.0#
		24"	PSXP4W24		9.0#

A

B

HOW TO ORDER

Indicate the following information on order form:

- Quantity of each item.
- Model number, including options. See "How To Build a Model Number".
- Any special service required.

Note: • The indicates that a choice is required.

- The absence of the indicates that no choice is required.
- Alpha-numeric characters in place of indicate that no other alternatives are available.

HOW TO BUILD A MODEL NUMBER

A Select basic model.

B Select fabric color.

HOW TO ORDER

Indicate the following information on order form:

1. Quantity of each item.
2. Model number, including options. See "How To Build a Model Number".
3. Any special service required.

Note:

- The indicates that a choice is required.
- The absence of the indicates that no choice is required.
- Alpha-numeric characters in place of indicate that no other alternatives are available.

6-2-2 Electrical

6-2-2 10-Wire System 6 Circuit "810"

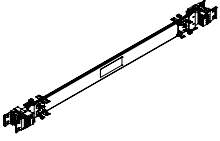
	MODEL	PANEL WIDTH	MODEL NUMBER	Approx. Packaged Weight
			Basic Model	
 <p>HRDPT</p> <p>Rigid Wireway - 6 Circuit</p> <ul style="list-style-type: none"> • Distributes 10-wire power and allows receptacle mounting • Non-directional • Includes mounting clips • Wireway can be mounted inside the base raceway or behind any raceway tile 30 thru 60 • Accommodates two duplex receptacles per side. Maximum of four per wireway as standard • Receptacles purchase separately • 24" wireway accommodates one duplex receptacle per side 		24"	PWET6WW.24	2.0#
		30"	PWET6WW.30	2.0#
		36"	PWET6WW.36	3.0#
		42"	PWET6WW.42	3.0#
		48"	PWET6WW.48	3.0#
		54"	PWET6WW.54	4.0#
		60"	PWET6WW.60	4.0#

A

HOW TO ORDER

Indicate the following information on order form:

1. Quantity of each item.
2. Model number, including options. See "How To Build a Model Number".
3. Any special service required.

Note: • The indicates that a choice is required.

- The absence of the indicates that no choice is required.
- Alpha-numeric characters in place of indicate that no other alternatives are available.

HOW TO BUILD A MODEL NUMBER

- A** Select basic model.

6-2-2 Electrical

6-2-2 10-Wire System 6 Circuit "810"

MODEL	PANEL WIDTH	MODEL NUMBER		Approx. Packaged Weight
		Basic Model		
<p>HRDPT</p>	Power Pass Through - 6 Circuit	12"	PWET6PP.12	1.0#
	<ul style="list-style-type: none"> Distributes 10-wire power Non-directional Connects to adjacent Rigid Wireway or Power Pass Through via a horizontal jumper Receptacle access is not provided Pass through is the same length as the corresponding Rigid Wireway Pass through requires panel to panel jumpers (ordered separately) 	18"	PWET6PP.18	1.0#
		24"	PWET6PP.24	1.0#
		30"	PWET6PP.30	2.0#
		36"	PWET6PP.36	2.0#
		42"	PWET6PP.42	2.0#
		48"	PWET6PP.48	2.0#
		54"	PWET6PP.54	3.0#
		60"	PWET6PP.60	3.0#
<p>HRDPT</p>	Power/Data Separation Septum	12"	PDS8.12.BL	1.0#
	<ul style="list-style-type: none"> Steel septum provides separation between power and data in base raceway Hint: A steel trough is supplied with raceway tiles to provide separation at other electrical heights 	18"	PDS8.18.BL	1.0#
		24"	PDS8.24.BL	1.0#
		30"	PDS8.30.BL	1.0#
		36"	PDS8.36.BL	2.0#
		42"	PDS8.42.BL	2.0#
		48"	PDS8.48.BL	2.0#
		54"	PDS8.54.BL	2.0#
		60"	PDS8.60.BL	2.0#

A

HOW TO ORDER

Indicate the following information on order form:

- Quantity of each item.
- Model number, including options. See "How To Build a Model Number".
- Any special service required.

Note:

- The indicates that a choice is required.
- The absence of the indicates that no choice is required.
- Alpha-numeric characters in place of indicate that no other alternatives are available.

HOW TO BUILD A MODEL NUMBER

- A** Select basic model.

6-2-2 Electrical

6-2-2 10-Wire System 6 Circuit "810"

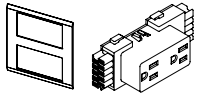
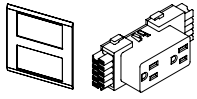
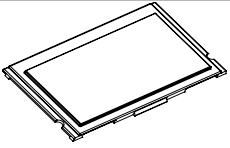
	MODEL	Features	MODEL NUMBER		Approx. Packaged Weight
			Basic Model	Trim Color	
 HRDPT	15 Amp Duplex Receptacle with Bezel - 6 Circuit <ul style="list-style-type: none"> • Snaps to wireways of powered panels • 4I, 5I and 6I circuits are stamped with orange triangle • Includes Bezel with filler plate which can be removed to accept standard modular furniture data plates • Receptacles can be used at any height power • Receptacle color matches trim color 	Circuit 1	PWET6RC.1	<input type="checkbox"/>	1.0#
		Circuit 2	PWET6RC.2	<input type="checkbox"/>	1.0#
		Circuit 3	PWET6RC.3	<input type="checkbox"/>	1.0#
		Circuit 4	PWET6RC.4I	<input type="checkbox"/>	1.0#
		Circuit 5	PWET6RC.5I	<input type="checkbox"/>	1.0#
		Circuit 6	PWET6RC.6I	<input type="checkbox"/>	1.0#
 HRDPT	20 Amp Simplex Receptacle with Bezel - 6 Circuit <ul style="list-style-type: none"> • Snaps to wireways of powered panels • Receptacle includes one 20 amp simplex and one 15 amp simplex • Occupies space of one duplex receptacle • 4I, 5I and 6I circuits are stamped with orange triangle • Includes Bezel with filler plate which can be removed to accept standard modular furniture data plates • Receptacles can be used at any height power • Receptacle color matches trim color 	Circuit 1	PWET620R.1	<input type="checkbox"/>	1.0#
		Circuit 2	PWET620R.2	<input type="checkbox"/>	1.0#
		Circuit 3	PWET620R.3	<input type="checkbox"/>	1.0#
		Circuit 4	PWET620R.4I	<input type="checkbox"/>	1.0#
		Circuit 5	PWET620R.5I	<input type="checkbox"/>	1.0#
		Circuit 6	PWET620R.6I	<input type="checkbox"/>	1.0#
 HRDPT	Bezel Filler <ul style="list-style-type: none"> • Specify trim color 		46.0074	<input type="checkbox"/>	1.0#

A

B

HOW TO ORDER

Indicate the following information on order form:

1. Quantity of each item.
2. Model number, including options. See "How To Build a Model Number".
3. Any special service required.

Note: • The indicates that a choice is required.

- The absence of the indicates that no choice is required.
- Alpha-numeric characters in place of indicate that no other alternatives are available.





HOW TO BUILD A MODEL NUMBER

A Select basic model.

B Select trim color.
Refer to the **Product Color Options** page in this catalog.
Metallic finish not available.

6-2-2 Electrical

6-2-2 10-Wire System 6 Circuit "810"

MODEL	L	MODEL NUMBER		Approx. Packaged Weight
		Basic Model		
 <p>17" Panel to Panel Jumper - 6 Circuit</p> <ul style="list-style-type: none"> • Used on in-line intersections • Non-directional 	17"	PWET6PJ.17		1.0#
HRDPT				
 <p>20" Panel to Panel Jumper - 6 Circuit</p> <ul style="list-style-type: none"> • Used on 90° corners and "T" intersections • Non-directional 	20"	PWET6PJ.20		1.0#
HRDPT				
 <p>20" Vertical Jumper - 6 Circuit</p> <ul style="list-style-type: none"> • Jumps power from ADA-height to worksurface-height or worksurface-height to stand-up-height • Non-directional 	20"	PWET6VJ.20		1.0#
HRDPT				
 <p>56" Vertical Jumper - 6 Circuit</p> <ul style="list-style-type: none"> • Jumps power from base to ADA-height, base to worksurface-height, base-height to stand-up height • Non-directional 	56"	PWET6VJ.56		2.0#
HRDPT				

A

HOW TO ORDER

Indicate the following information on order form:

1. Quantity of each item.
2. Model number, including options. See "How To Build a Model Number".
3. Any special service required.

Note:



- The indicates that a choice is required.
- The absence of the indicates that no choice is required.
- Alpha-numeric characters in place of indicate that no other alternatives are available.

HOW TO BUILD A MODEL NUMBER

A Select basic model.

6-2-2 Electrical

6-2-2 10-Wire System 6 Circuit "810"

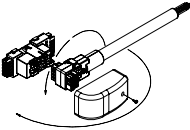
	MODEL	L	MODEL NUMBER		Approx. Packaged Weight
			Basic Model	Trim Color	
 HRDPT	Top Feed with 7' or 10' Pole - 6 Circuit <ul style="list-style-type: none"> • Can be used at top of panel only • Connects to either end of Rigid Wireway at any level. Doesn't occupy space for duplex receptacle • Includes aluminum power pole, panel trim and ceiling trim • Specify trim color 	7"	PWET6TF7	<input type="checkbox"/>	10.0#
		10"	PWET6TF10	<input type="checkbox"/>	15.0#
 HRDPT	Data Feed <ul style="list-style-type: none"> • Can be used at top of panel only • Includes aluminum power pole, panel trim and ceiling trim • Pole is available in two heights, 7' and 10' • Specify trim color 	84"	PDF8.7	<input type="checkbox"/>	7.0#
		120"	PDF8.10	<input type="checkbox"/>	10.0#
 HRDPT	Universal Base Infeed with Bezel - 6 Circuit <ul style="list-style-type: none"> • Field notable for left, right and straight applications • Can be used at base level only • Includes Bezel with filler plate which can be removed to accept standard modular furniture data plates • 72" Whip is color matched to trim • Non-directional 	72"	PWET6BFU		4.0#

A

B

HOW TO ORDER

Indicate the following information on order form:

1. Quantity of each item.
2. Model number, including options. See "How To Build a Model Number".
3. Any special service required.

Note: • The indicates that a choice is required.

- The absence of the indicates that no choice is required.
- Alpha-numeric characters in place of indicate that no other alternatives are available.

HOW TO BUILD A MODEL NUMBER

- A** Select basic model.
- B** Select trim color. Refer to the **Product Color Options** page in this catalog.

6-2-2 Electrical

6-2-2 10-Wire System 6 Circuit "810"

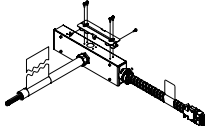
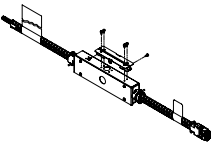
	MODEL	L	MODEL NUMBER		Approx. Packaged Weight
			Basic Model	Trim Color	
 <p>HRDPT</p>	New York Power Infeed with Bezel - 6 Circuit <ul style="list-style-type: none"> • City of New York approved power entry box with panel to panel connectors • Can be used at base level only • 72" Whip is color matched to trim • Entry box is mounted to bottom horizontal on left or right side of panel • 14" panel jumper is hard wired to infeed box and plugs into wireway of adjacent panel 	72"	PWET6NYBF.72	<input type="checkbox"/>	6.0#
 <p>HRDPT</p>	New York Power Infeed Kit/Ceiling - 6 Circuit <ul style="list-style-type: none"> • Order power/data pole (PDF8. size(colors)) separately 	216"	PWET6NYTF.216		6.0#

A

B

HOW TO ORDER

Indicate the following information on order form:

1. Quantity of each item.
2. Model number, including options. See "How To Build a Model Number".
3. Any special service required.

Note: • The indicates that a choice is required.

- The absence of the indicates that no choice is required.
- Alpha-numeric characters in place of indicate that no other alternatives are available.

HOW TO BUILD A MODEL NUMBER

- A** Select basic model.
- B** Select trim color.
Refer to the **Product Color Options** page in this catalog.

4-4-2 Electrical

4-4-2 10-Wire System 4 Circuit "810"

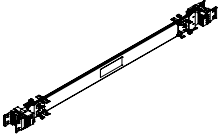
	MODEL	PANEL WIDTH	MODEL NUMBER	Approx. Packaged Weight
			Basic Model	
 <p>HRDPT</p> <p>Rigid Wireway - 4 Circuit</p> <ul style="list-style-type: none"> • Distributes 10-wire power and allows receptacle mounting • Non-directional • Includes mounting clips • Wireway can be mounted inside the base raceway or behind any raceway tile 30 thru 60 • Accommodates two deuplex receptacles per side. Maximum of two per wireway as standard • 24" wireway accommodates one duplex receptacle per side • Receptacles purchased separately 		24"	PWET4WW.24	2.0#
		30"	PWET4WW.30	2.0#
		36"	PWET4WW.36	3.0#
		42"	PWET4WW.42	3.0#
		48"	PWET4WW.48	3.0#
		54"	PWET4WW.54	4.0#
		60"	PWET4WW.60	4.0#

A

HOW TO ORDER

Indicate the following information on order form:

1. Quantity of each item.
2. Model number, including options. See "How To Build a Model Number".
3. Any special service required.

Note: • The indicates that a choice is required.

- The absence of the indicates that no choice is required.
- Alpha-numeric characters in place of indicate that no other alternatives are available.

HOW TO BUILD A MODEL NUMBER

A Select basic model.

4-4-2 Electrical

4-4-2 10-Wire System 4 Circuit "810"

MODEL	PANEL WIDTH	MODEL NUMBER		Approx. Packaged Weight
		Basic Model		
<p>HRDPT</p>	Power Pass Through - 4 Circuit	12"	PWET4PP.12	1.0#
	<ul style="list-style-type: none"> Distributes 10-wire power Non-directional Connects to adjacent Rigid Wireway or Power Pass Through via a horizontal jumper Receptacle access is not provided Pass through is the same length as the corresponding Rigid Wireway Pass through requires panel to panel jumpers (ordered separately) 	18"	PWET4PP.18	1.0#
		24"	PWET4PP.24	1.0#
		30"	PWET4PP.30	2.0#
		36"	PWET4PP.36	2.0#
		42"	PWET4PP.42	2.0#
		48"	PWET4PP.48	2.0#
		54"	PWET4PP.54	3.0#
		60"	PWET4PP.60	3.0#
<p>HRDPT</p>	Power/Data Separation Septum	12"	PDS8.12.BL	1.0#
	<ul style="list-style-type: none"> Steel septum provides separation between power and data in base raceway Hint: A steel trough is supplied with raceway tiles to provide separation at other electrical heights 	18"	PDS8.18.BL	1.0#
		24"	PDS8.24.BL	1.0#
		30"	PDS8.30.BL	1.0#
		36"	PDS8.36.BL	2.0#
		42"	PDS8.42.BL	2.0#
		48"	PDS8.48.BL	2.0#
		54"	PDS8.54.BL	2.0#
	60"	PDS8.60.BL	2.0#	

A

HOW TO ORDER

Indicate the following information on order form:

- Quantity of each item.
- Model number, including options. See "How To Build a Model Number".
- Any special service required.

Note: • The indicates that a choice is required.

- The absence of the indicates that no choice is required.
- Alpha-numeric characters in place of indicate that no other alternatives are available.

HOW TO BUILD A MODEL NUMBER

A Select basic model.

4-4-2 Electrical

4-4-2 10-Wire System 4 Circuit "810"

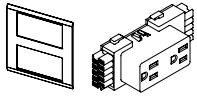
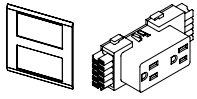
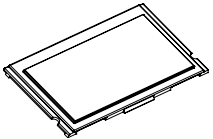
	MODEL	Features	MODEL NUMBER		Approx. Packaged Weight
			Basic Model	Trim Color	
 HRDPT	15 Amp Duplex Receptacle with Bezel - 4 Circuit <ul style="list-style-type: none"> • Snaps to wireways of powered panels • 3I and 4I circuits are stamped with orange triangle • Includes Bezel with filler plate which can be removed to accept standard modular furniture data plates • Receptacles can be used at any height power • Receptacle color matches trim color 	Circuit 1	PWET4RC.1	<input type="checkbox"/>	1.0#
		Circuit 2	PWET4RC.2	<input type="checkbox"/>	1.0#
		Circuit 3	PWET4RC.3I	<input type="checkbox"/>	1.0#
		Circuit 4	PWET4RC.4I	<input type="checkbox"/>	1.0#
 HRDPT	20 Amp Simplex Receptacle with Bezel - 4 Circuit <ul style="list-style-type: none"> • Snaps to wireways of powered panels • Receptacle includes one 20 amp simplex and one 15 amp simplex • Occupies space of one duplex receptacle • 4I, circuits are stamped with orange triangle • Includes Bezel with filler plate which can be removed to accept standard modular furniture data plates • Receptacles can be used at any height power • Receptacle color matches trim color 	Circuit 1	PWET420R.1	<input type="checkbox"/>	1.0#
		Circuit 2	PWET420R.2	<input type="checkbox"/>	1.0#
		Circuit 4	PWET420R.4I	<input type="checkbox"/>	1.0#
 HRDPT	Bezel Filler <ul style="list-style-type: none"> • Specify trim color 		46.0074	<input type="checkbox"/>	1.0#

A

B

HOW TO ORDER

Indicate the following information on order form:

1. Quantity of each item.
2. Model number, including options. See "How To Build a Model Number".
3. Any special service required.

Note: • The indicates that a choice is required.

- The absence of the indicates that no choice is required.
- Alpha-numeric characters in place of indicate that no other alternatives are available.





HOW TO BUILD A MODEL NUMBER

A Select basic model.

B Select trim color.
Refer to the **Product Color Options** page in this catalog.
Metallic finish not available.

4-4-2 Electrical

4-4-2 10-Wire System 4 Circuit "810"

MODEL	L	MODEL NUMBER		Approx. Packaged Weight
			Basic Model	
 <p>17" Panel to Panel Jumper - 4 Circuit</p> <ul style="list-style-type: none"> Used on in-line and inside 90° corner intersections Non-directional 	17"	PWET4PJ.17		1.0#
HRDPT				
 <p>20" Panel to Panel Jumper - 4 Circuit</p> <ul style="list-style-type: none"> Used on outside 90° corners and straight through "T" intersections Non-directional 	20"	PWET4PJ.20		1.0#
HRDPT				
 <p>20" Vertical Jumper - 4 Circuit</p> <ul style="list-style-type: none"> Jumps power from ADA-height to worksurface-height or worksurface-height to stand-up-height Non-directional 	20"	PWET4VJ.20		1.0#
HRDPT				
 <p>56" Vertical Jumper - 4 Circuit</p> <ul style="list-style-type: none"> Jumps power from base to ADA-height, base to worksurface-height, base-height to stand-up height Non-directional 	56"	PWET4VJ.56		2.0#
HRDPT				

A

HOW TO ORDER

Indicate the following information on order form:

- Quantity of each item.
- Model number, including options. See "How To Build a Model Number".
- Any special service required.



- Note:
- The indicates that a choice is required.
 - The absence of the indicates that no choice is required.
 - Alpha-numeric characters in place of indicate that no other alternatives are available.

HOW TO BUILD A MODEL NUMBER

- A** Select basic model.

4-4-2 Electrical

4-4-2 10-Wire System 4 Circuit "810"

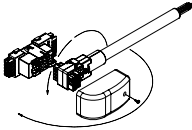
	MODEL	L	MODEL NUMBER		Approx. Packaged Weight
			Basic Model	Trim Color	
 HRDPT	Top Infeed with 7' or 10' Pole - 4 Circuit <ul style="list-style-type: none"> • Can be used at top of panel only • Connects to either end of Rigid Wireway at any level. Doesn't occupy space for duplex receptacle • Includes aluminum power pole, panel trim and ceiling trim • Specify trim color 	7"	PWET4TF7	<input type="checkbox"/>	10.0#
		10"	PWET4TF10	<input type="checkbox"/>	15.0#
 HRDPT	Data Feed <ul style="list-style-type: none"> • Can be used at top of panel only • Includes aluminum power pole, panel trim and ceiling trim • Pole is available in two heights, 7' and 10' • Specify trim color 	84"	PDF8.7	<input type="checkbox"/>	7.0#
		120"	PDF8.10	<input type="checkbox"/>	10.0#
 HRDPT	Universal Base Infeed with Bezel - 4 Circuit <ul style="list-style-type: none"> • Field notable for left, right and straight applications • Can be used at base level only • Includes Bezel with filler plate which can be removed to accept standard modular furniture data plates • 72" Whip is color matched to trim • Non-directional 	72"	PWET4BFU		4.0#

A

B

HOW TO ORDER

Indicate the following information on order form:

1. Quantity of each item.
2. Model number, including options. See "How To Build a Model Number".
3. Any special service required.

Note: • The indicates that a choice is required.

- The absence of the indicates that no choice is required.
- Alpha-numeric characters in place of indicate that no other alternatives are available.

HOW TO BUILD A MODEL NUMBER

- A** Select basic model.
- B** Select trim color. Refer to the **Product Color Options** page in this catalog.

4-4-2 Electrical

4-4-2 10-Wire System 4 Circuit "810"

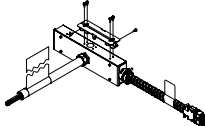
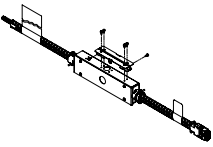
	MODEL	L	MODEL NUMBER		Approx. Packaged Weight
			Basic Model	Trim Color	
 HRDPT	New York Power Infeed with Bezel - 4 Circuit <ul style="list-style-type: none"> • City of New York approved power entry box with panel to panel connector • Can be used at base level only • 72" Whip is color matched to trim • Entry box is mounted to bottom horizontal on left or right side of panel • 14" panel jumper is hard wired to infeed box and plugs into wireway of adjacent panel 	72"	PWET4NYBF.72	<input type="checkbox"/>	6.0#
 HRDPT	New York Power Infeed Kit/Ceiling - 4 Circuit <ul style="list-style-type: none"> • Order power/data pole (PDF8.size(color)) separately 	216"	PWET4NYTF.216	<input type="checkbox"/>	6.0#

A

B

HOW TO ORDER

Indicate the following information on order form:

1. Quantity of each item.
2. Model number, including options. See "How To Build a Model Number".
3. Any special service required.

Note: • The indicates that a choice is required.

- The absence of the indicates that no choice is required.
- Alpha-numeric characters in place of indicate that no other alternatives are available.

HOW TO BUILD A MODEL NUMBER

- A** Select basic model.
- B** Select trim color.
Refer to the **Product Color Options** page in this catalog.

Cable Management

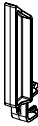
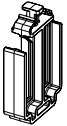
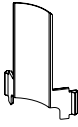
	MODEL	MODEL NUMBER	
		Basic Model	Approx. Packaged Weight
 HRDPT	Acoustical Tile Vertical Cable Guide <ul style="list-style-type: none"> • Clips into slots in vertical post • Allows cables to be laid in-between vertical posts and acoustic tile • Cannot be used with raceway tile • Maximum of two guides behind a 12" high acoustic tile • Ordered in packs of 25 	46.0097.PCK	0.2#
 HRDPT	Acoustical Tile Horizontal Cable Support <ul style="list-style-type: none"> • Clips into bottom midpoint of horizontal rail • Aligns with vertical cable guides to keep cables supported at midpoint of panel • Cable supports gang vertically • Can also support loops of cable • Cannot be used with raceway tile • Ordered in packs of 25 	46.0099.PCK	0.2#
 HRDPT	Tile 90 Cable Guard <ul style="list-style-type: none"> • Clips into slots in vertical post • Allows cables to be laid in-between vertical posts and acoustic tile at the inside of a 90° corner • Cannot be used with raceway tile • Need two guides per 12" high tile • Ordered in packs of 25 	46.0096.PCK	0.2#

A

HOW TO ORDER

Indicate the following information on order form:

1. Quantity of each item.
2. Model number, including options. See "How To Build a Model Number".
3. Any special service required.



Note: • The indicates that a choice is required.

- The absence of the indicates that no choice is required.
- Alpha-numeric characters in place of indicate that no other alternatives are available.

HOW TO BUILD A MODEL NUMBER

- A** Select basic model.

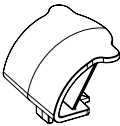
Cable Management

	MODEL	MODEL NUMBER	
		Basic Model	Approx. Packaged Weight
 <p>HRDPT</p>	<p>Horizontal Rail Cable Guard</p> <ul style="list-style-type: none"> • Clips into end notch of horizontal rail • Protects and manages cables • Ordered in packs of 25 	46.0098.PCK	0.2#
 <p>HRDPT</p>	<p>Top Cap 90° Cable Guard</p> <ul style="list-style-type: none"> • Manages cables between half posts and under top cap • Protects and manages cables • Ordered in packs of 25 	46.0200.PCK	1.0#

A

HOW TO ORDER

Indicate the following information on order form:

1. Quantity of each item.
2. Model number, including options. See "How To Build a Model Number".
3. Any special service required.

Note:



- The indicates that a choice is required.
- The absence of the indicates that no choice is required.
- Alpha-numeric characters in place of indicate that no other alternatives are available.

HOW TO BUILD A MODEL NUMBER

A Select basic model.

Worksurfaces

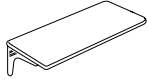
Rectangular

	MODEL	D x W	MODEL NUMBER							Approx. Packaged Weight
			Basic Model	Edge Style	Surface Finish	Trim Color	Grommet Location	Edge Color	Grommet Color	
 <p>Flat Vinyl T-Edge (BN)</p> <p>P1NW - KD1-No Wood PWR - Pass Through With Wood</p>	Rectangular Worksurfaces - 24" D	24 x 24"	PWR2424	<input type="checkbox"/>	<input type="checkbox"/>	<input type="checkbox"/>	<input type="checkbox"/>	<input type="checkbox"/>	23.0#	
	• 60" worksurfaces contain two steel reinforcing bars	24 x 30"	PWR2430	<input type="checkbox"/>	<input type="checkbox"/>	<input type="checkbox"/>	<input type="checkbox"/>	<input type="checkbox"/>	28.0#	
	• Includes worksurface supports	24 x 36"	PWR2436	<input type="checkbox"/>	<input type="checkbox"/>	<input type="checkbox"/>	<input type="checkbox"/>	<input type="checkbox"/>	33.0#	
	• All surfaces 66" and longer are provided with an additional left-hand cantilever bracket	24 x 42"	PWR2442	<input type="checkbox"/>	<input type="checkbox"/>	<input type="checkbox"/>	<input type="checkbox"/>	<input type="checkbox"/>	37.0#	
	• Worksurfaces with 74P, postformed, knife edge and veneer edges have one 2-1/2" x 6" grommet up to 54" wide, 60" - 96" have two grommets	24 x 48"	PWR2448	<input type="checkbox"/>	<input type="checkbox"/>	<input type="checkbox"/>	<input type="checkbox"/>	<input type="checkbox"/>	42.0#	
		24 x 54"	PWR2454	<input type="checkbox"/>	<input type="checkbox"/>	<input type="checkbox"/>	<input type="checkbox"/>	<input type="checkbox"/>	46.0#	
		24 x 60"	PWR2460	<input type="checkbox"/>	<input type="checkbox"/>	<input type="checkbox"/>	<input type="checkbox"/>	<input type="checkbox"/>	51.0#	
		24 x 66"	PWR2466	<input type="checkbox"/>	<input type="checkbox"/>	<input type="checkbox"/>	<input type="checkbox"/>	<input type="checkbox"/>	56.0#	
		• 3" diameter grommet optional on vinyl T-edge worksurfaces only	24 x 72"	PWR2472	<input type="checkbox"/>	<input type="checkbox"/>	<input type="checkbox"/>	<input type="checkbox"/>	<input type="checkbox"/>	61.0#
		24 x 78"	PWR2478	<input type="checkbox"/>	<input type="checkbox"/>	<input type="checkbox"/>	<input type="checkbox"/>	<input type="checkbox"/>	66.0#	
		24 x 84"	PWR2484	<input type="checkbox"/>	<input type="checkbox"/>	<input type="checkbox"/>	<input type="checkbox"/>	<input type="checkbox"/>	71.0#	
		24 x 90"	PWR2490	<input type="checkbox"/>	<input type="checkbox"/>	<input type="checkbox"/>	<input type="checkbox"/>	<input type="checkbox"/>	74.0#	
		24 x 96"	PWR2496	<input type="checkbox"/>	<input type="checkbox"/>	<input type="checkbox"/>	<input type="checkbox"/>	<input type="checkbox"/>	76.0#	
		 <p>74P Edge (74P) Postformed Edge (PL) Wood Edge (WV)</p> <p>P1NW - KD1-No Wood PWR - Pass Through With Wood</p>	Rectangular Worksurfaces - 30" D	30 x 24"	PWR3024	<input type="checkbox"/>	<input type="checkbox"/>	<input type="checkbox"/>	<input type="checkbox"/>	<input type="checkbox"/>
30 x 30"	PWR3030		<input type="checkbox"/>	<input type="checkbox"/>	<input type="checkbox"/>	<input type="checkbox"/>	<input type="checkbox"/>	34.0#		
30 x 36"	PWR3036		<input type="checkbox"/>	<input type="checkbox"/>	<input type="checkbox"/>	<input type="checkbox"/>	<input type="checkbox"/>	40.0#		
30 x 42"	PWR3042		<input type="checkbox"/>	<input type="checkbox"/>	<input type="checkbox"/>	<input type="checkbox"/>	<input type="checkbox"/>	46.0#		
30 x 48"	PWR3048		<input type="checkbox"/>	<input type="checkbox"/>	<input type="checkbox"/>	<input type="checkbox"/>	<input type="checkbox"/>	57.0#		
30 x 54"	PWR3054		<input type="checkbox"/>	<input type="checkbox"/>	<input type="checkbox"/>	<input type="checkbox"/>	<input type="checkbox"/>	62.0#		
30 x 60"	PWR3060		<input type="checkbox"/>	<input type="checkbox"/>	<input type="checkbox"/>	<input type="checkbox"/>	<input type="checkbox"/>	68.0#		
30 x 66"	PWR3066		<input type="checkbox"/>	<input type="checkbox"/>	<input type="checkbox"/>	<input type="checkbox"/>	<input type="checkbox"/>	72.0#		
30 x 72"	PWR3072		<input type="checkbox"/>	<input type="checkbox"/>	<input type="checkbox"/>	<input type="checkbox"/>	<input type="checkbox"/>	79.0#		
30 x 78"	PWR3078		<input type="checkbox"/>	<input type="checkbox"/>	<input type="checkbox"/>	<input type="checkbox"/>	<input type="checkbox"/>	85.0#		
30 x 84"	PWR3084		<input type="checkbox"/>	<input type="checkbox"/>	<input type="checkbox"/>	<input type="checkbox"/>	<input type="checkbox"/>	89.0#		
30 x 90"	PWR3090		<input type="checkbox"/>	<input type="checkbox"/>	<input type="checkbox"/>	<input type="checkbox"/>	<input type="checkbox"/>	92.0#		
30 x 96"	PWR3096		<input type="checkbox"/>	<input type="checkbox"/>	<input type="checkbox"/>	<input type="checkbox"/>	<input type="checkbox"/>	94.0#		
				A	B	C	D	E	F	G

HOW TO ORDER

Indicate the following information on order form:

- Quantity of each item.
- Model number, including options. See "How To Build a Model Number".
- Any special service required.

Note: • The indicates that a choice is required.

- The absence of the indicates that no choice is required.
- Alpha-numeric characters in place of indicate that no other alternatives are available.

HOW TO BUILD A MODEL NUMBER

A Select basic model.

B Select edge style.

BN - Flat vinyl T-edge
74P - 74P edge

C Select surface finish.

Refer to the **Product Color Options** page in this catalog.
Surface finish offerings are based on edge style selections.

D Select trim color.

Refer to the **Product Color Options** page in this catalog.

E Select grommet location.

N - No grommet
L - Grommet : left
C - Grommet : Center
R - Grommet : right
LR - Grommet : left/right
LC - Grommet : left/center
CR - Grommet : center/right
LCR - Grommet : left/center/right

F Select edge color.

Refer to the **Product Color Options** page in this catalog.

G Select grommet color.

Refer to the **Product Color Options** page in this catalog.

FINISH INFORMATION

Additional Laminate Offering

Additional laminates beyond the standard offering, are available with two weeks extended leadtime. To specify additional laminates, use these designators followed by the supplier's color/pattern code:

Formica - LF/supplier's color pattern code
Nevamar - LN/supplier's color pattern code
Wilsonart - LW/supplier's color pattern code

The standard finish is the supplier's recommended finish for that color/pattern.

Worksurfaces

"P" Shaped Peninsula/Piano Peninsula

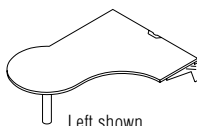
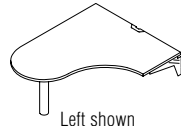
MODEL	D x W x L	MODEL NUMBER							Approx. Packaged Weight
		Basic Model	Dir.	Edge Style	Surface Finish	Trim Color	Edge Color	Grommet Color	
 <p>Left shown</p> <p>P1NW - KD1-No Wood PWPR - Pass Through</p>	24 x 48 x 60"	PWPT244860	<input type="checkbox"/>	<input type="checkbox"/>	<input type="checkbox"/>	<input type="checkbox"/>	<input type="checkbox"/>	<input type="checkbox"/>	65.0#
	24 x 48 x 72"	PWPT244872	<input type="checkbox"/>	<input type="checkbox"/>	<input type="checkbox"/>	<input type="checkbox"/>	<input type="checkbox"/>	<input type="checkbox"/>	79.0#
	30 x 48 x 72"	PWPT304872	<input type="checkbox"/>	<input type="checkbox"/>	<input type="checkbox"/>	<input type="checkbox"/>	<input type="checkbox"/>	<input type="checkbox"/>	88.0#
 <p>Left shown</p> <p>P1NW - KD1-No Wood PWPR - Pass Through</p>	24 x 48 x 60"	PWPP244860	<input type="checkbox"/>	<input type="checkbox"/>	<input type="checkbox"/>	<input type="checkbox"/>	<input type="checkbox"/>	<input type="checkbox"/>	57.0#
	24 x 48 x 72"	PWPP244872	<input type="checkbox"/>	<input type="checkbox"/>	<input type="checkbox"/>	<input type="checkbox"/>	<input type="checkbox"/>	<input type="checkbox"/>	72.0#
	30 x 48 x 72"	PWPP304872	<input type="checkbox"/>	<input type="checkbox"/>	<input type="checkbox"/>	<input type="checkbox"/>	<input type="checkbox"/>	<input type="checkbox"/>	82.0#

A **B** **C** **D** **E** **F** **G**

HOW TO ORDER

Indicate the following information on order form:

- Quantity of each item.
- Model number, including options. See "How To Build a Model Number".
- Any special service required.

Note: • The indicates that a choice is required.

- The absence of the indicates that no choice is required.
- Alpha-numeric characters in place of indicate that no other alternatives are available.

HOW TO BUILD A MODEL NUMBER

A Select basic model.

B Select surface direction.

DL _____ - Direction left

DR _____ - Direction right

Direction is determined by the side of the work surface that adjoins an adjacent work surface.

C Select edge style.

74P _____ - 74P edge

KN _____ - Knife edge

D Select surface finish.

Refer to the **Product Color Options** page in this catalog. Surface finish offerings are based on edge style selections.

E Select trim color.

Refer to the **Product Color Options** page in this catalog.

F Select edge color.

Refer to the **Product Color Options** page in this catalog.

G Select grommet color.

Refer to the **Product Color Options** page in this catalog.

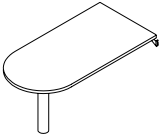
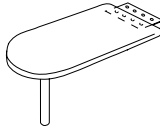
	MODEL	D x W	MODEL NUMBER							Approx. Packaged Weight
			Basic Model	Edge Style	Surface Finish	Trim Color	Grommet Location	Edge Color	Grommet Color	
 <p>P1NW - KD1-No Wood PWCD - Pass Through</p>	"D" Shaped Peninsula Worksurfaces <ul style="list-style-type: none"> Not available with laminate postformed edge Includes mounting hardware 72" worksurfaces contain two steel reinforcing bars Round grommets optional Flat vinyl T-edge is available with 3" diameter grommets (30" or 36" edge only) Veneer option must be ordered via Specials Dept (a. Specify left, right or center b. Specify depth of adjacent worksurface) 	30 x 48"	PWP3048	<input type="checkbox"/>	<input type="checkbox"/>	<input type="checkbox"/>	<input type="checkbox"/>	<input type="checkbox"/>	<input type="checkbox"/>	53.0#
		30 x 60"	PWP3060	<input type="checkbox"/>	<input type="checkbox"/>	<input type="checkbox"/>	<input type="checkbox"/>	<input type="checkbox"/>	<input type="checkbox"/>	63.0#
		30 x 72"	PWP3072	<input type="checkbox"/>	<input type="checkbox"/>	<input type="checkbox"/>	<input type="checkbox"/>	<input type="checkbox"/>	<input type="checkbox"/>	76.0#
		36 x 60"	PWP3660	<input type="checkbox"/>	<input type="checkbox"/>	<input type="checkbox"/>	<input type="checkbox"/>	<input type="checkbox"/>	<input type="checkbox"/>	75.0#
		36 x 72"	PWP3672	<input type="checkbox"/>	<input type="checkbox"/>	<input type="checkbox"/>	<input type="checkbox"/>	<input type="checkbox"/>	<input type="checkbox"/>	89.0#
 <p>P1NW - KD1-No Wood PWCD - Pass Through</p>	"D" Shaped Peninsula Worksurface Mounts to Another Worksurface <ul style="list-style-type: none"> Not available with laminate postformed edge Does not include wire management grommet Includes mounting hardware 72" worksurfaces contain two steel reinforcing bars 	30 x 48"	PWSMP3048	<input type="checkbox"/>	<input type="checkbox"/>	<input type="checkbox"/>	<input type="checkbox"/>	<input type="checkbox"/>	<input type="checkbox"/>	54.0#
		30 x 60"	PWSMP3060	<input type="checkbox"/>	<input type="checkbox"/>	<input type="checkbox"/>	<input type="checkbox"/>	<input type="checkbox"/>	<input type="checkbox"/>	64.0#
		30 x 72"	PWSMP3072	<input type="checkbox"/>	<input type="checkbox"/>	<input type="checkbox"/>	<input type="checkbox"/>	<input type="checkbox"/>	<input type="checkbox"/>	77.0#

A **B** **C** **D** **E** **F** **G**

HOW TO ORDER

Indicate the following information on order form:

- Quantity of each item.
- Model number, including options. See "How To Build a Model Number".
- Any special service required.

Note: • The indicates that a choice is required.
 • The absence of the indicates that no choice is required.
 • Alpha-numeric characters in place of indicate that no other alternatives are available.

HOW TO BUILD A MODEL NUMBER





- A** Select basic model.
- B** Select edge style.

BN	- Flat vinyl T-edge
74P	- 74P edge
- C** Select surface finish. Refer to the **Product Color Options** page in this catalog. Surface finish offerings are based on edge style selections.
- D** Select trim color. Refer to the **Product Color Options** page in this catalog.
- E** Select grommet location on T-edge (BN) only.

N	- No grommet
L	- Grommet : left
C	- Grommet : Center
R	- Grommet : right
LR	- Grommet : left/right
LC	- Grommet: left/center
CR	- Grommet: center/right
LCR	- Grommet : left/center/right
- F** Select edge color. Refer to the **Product Color Options** page in this catalog.
- G** Select grommet color. Refer to the **Product Color Options** page in this catalog. For 'T-Edge (BN) only.

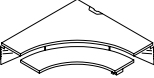
Worksurfaces

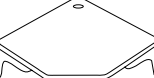
Dual Curvilinear/Diag/Curvilinear 90° Corner

MODEL	D x W-LEFT x W-RIGHT x D	MODEL NUMBER					Approx. Packaged Weight	
		Basic Model	Edge Style	Surface Finish	Edge Color	Grommet Color		
 <p>P1NW - KD1-No Wood PWWC - Pass Through</p>	Dual Curvilinear/Diag/Curvilinear 90° Corner	24 x 42 x 42 x 24"	PWDCE244224	<input type="checkbox"/>	<input type="checkbox"/>	<input type="checkbox"/>	<input type="checkbox"/>	75.0#
	<ul style="list-style-type: none"> Includes mounting hardware Worksurfaces have one 2-1/2" x 6" grommet located 12" from rear corner along right rear edge 	24 x 48 x 48 x 24"	PWDCE244824	<input type="checkbox"/>	<input type="checkbox"/>	<input type="checkbox"/>	<input type="checkbox"/>	84.0#
		30 x 48 x 48 x 30"	PWDCE304830	<input type="checkbox"/>	<input type="checkbox"/>	<input type="checkbox"/>	<input type="checkbox"/>	98.0#
 <p>74P Edge (74P)</p>  <p>Flat Vinyl T-Edge (BN)</p> <p>P1NW - KD1-No Wood PWWC - Pass Through</p>	Diagonal 90° Corner Worksurface	24 x 36 x 36 x 24"	PWD243624	<input type="checkbox"/>	<input type="checkbox"/>	<input type="checkbox"/>	<input type="checkbox"/>	46.0#
	<ul style="list-style-type: none"> Includes mounting hardware Left-hand cantilever is provided for rear corner Includes one grommet 	24 x 42 x 42 x 24"	PWD244224	<input type="checkbox"/>	<input type="checkbox"/>	<input type="checkbox"/>	<input type="checkbox"/>	55.0#
		24 x 42 x 42 x 30"	PWD244230	<input type="checkbox"/>	<input type="checkbox"/>	<input type="checkbox"/>	<input type="checkbox"/>	51.0#
		24 x 48 x 48 x 24"	PWD244824	<input type="checkbox"/>	<input type="checkbox"/>	<input type="checkbox"/>	<input type="checkbox"/>	64.0#
		24 x 48 x 48 x 30"	PWD244830	<input type="checkbox"/>	<input type="checkbox"/>	<input type="checkbox"/>	<input type="checkbox"/>	62.0#
		30 x 42 x 42 x 24"	PWD304224	<input type="checkbox"/>	<input type="checkbox"/>	<input type="checkbox"/>	<input type="checkbox"/>	51.0#
		30 x 42 x 42 x 30"	PWD304230	<input type="checkbox"/>	<input type="checkbox"/>	<input type="checkbox"/>	<input type="checkbox"/>	69.0#
		30 x 48 x 48 x 24"	PWD304824	<input type="checkbox"/>	<input type="checkbox"/>	<input type="checkbox"/>	<input type="checkbox"/>	62.0#
		30 x 48 x 48 x 30"	PWD304830	<input type="checkbox"/>	<input type="checkbox"/>	<input type="checkbox"/>	<input type="checkbox"/>	78.0#
 <p>74P Edge (74P)</p> <p>P1NW - KD1-No Wood PWWC - Pass Through</p>	Curvilinear 90° Corner Worksurfaces	24 x 36 x 36 x 24"	PWC243624	<input type="checkbox"/>	<input type="checkbox"/>	<input type="checkbox"/>	<input type="checkbox"/>	44.0#
	<ul style="list-style-type: none"> Includes mounting hardware Left-hand cantilever is provided for rear corner 	24 x 42 x 42 x 24"	PWC244224	<input type="checkbox"/>	<input type="checkbox"/>	<input type="checkbox"/>	<input type="checkbox"/>	53.0#
		24 x 42 x 42 x 30"	PWC244230	<input type="checkbox"/>	<input type="checkbox"/>	<input type="checkbox"/>	<input type="checkbox"/>	49.0#
		24 x 48 x 48 x 24"	PWC244824	<input type="checkbox"/>	<input type="checkbox"/>	<input type="checkbox"/>	<input type="checkbox"/>	62.0#
		24 x 48 x 48 x 30"	PWC244830	<input type="checkbox"/>	<input type="checkbox"/>	<input type="checkbox"/>	<input type="checkbox"/>	60.0#
		30 x 36 x 36 x 30"	PWC303630	<input type="checkbox"/>	<input type="checkbox"/>	<input type="checkbox"/>	<input type="checkbox"/>	49.0#
		30 x 42 x 42 x 24"	PWC304224	<input type="checkbox"/>	<input type="checkbox"/>	<input type="checkbox"/>	<input type="checkbox"/>	49.0#
		30 x 42 x 42 x 30"	PWC304230	<input type="checkbox"/>	<input type="checkbox"/>	<input type="checkbox"/>	<input type="checkbox"/>	67.0#
		30 x 48 x 48 x 24"	PWC304824	<input type="checkbox"/>	<input type="checkbox"/>	<input type="checkbox"/>	<input type="checkbox"/>	60.0#
		30 x 48 x 48 x 30"	PWC304830	<input type="checkbox"/>	<input type="checkbox"/>	<input type="checkbox"/>	<input type="checkbox"/>	76.0#

A

B

C

D

E

HOW TO ORDER

Indicate the following information on order form:

- Quantity of each item.
- Model number, including options. See "How To Build a Model Number".
- Any special service required.

Note: • The indicates that a choice is required.

- The absence of the indicates that no choice is required.
- Alpha-numeric characters in place of

indicate that no other alternatives are available.

HOW TO BUILD A MODEL NUMBER

A Select basic model.

B Select edge style.

BN - Flat vinyl T-edge

74P - 74P edge

C Select surface finish.

Refer to the **Product Color Options** page in this catalog.
Surface finish offerings are based on edge style selections.

D Select grommet color.

Refer to the **Product Color Options** page in this catalog.

E Select edge color.

Refer to the **Product Color Options** page in this catalog.

F Select grommet color.

Refer to the **Product Color Options** page in this catalog.

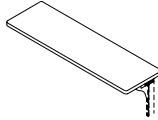
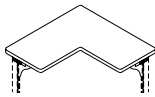
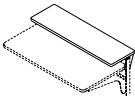
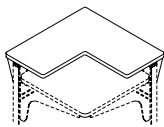
	MODEL	Features	D x W	MODEL NUMBER							Approx. Packaged Weight	
				Basic Model	Notch Location	Edge Style	Surface Finish	Trim Color	Edge Color	Grommet Color		
 <p>P1NW - KD1-No Wood PWCT - Pass Through</p>	Straight Countertops		16 x 24"	PWCT24	<input type="checkbox"/>	<input type="checkbox"/>	<input type="checkbox"/>	<input type="checkbox"/>	<input type="checkbox"/>	<input type="checkbox"/>	<input type="checkbox"/>	16.0#
		• For notch location of "LS, RS, BS", the notch has a grommet and will require a grommet color selection	16 x 30"	PWCT30	<input type="checkbox"/>	<input type="checkbox"/>	<input type="checkbox"/>	<input type="checkbox"/>	<input type="checkbox"/>	<input type="checkbox"/>	<input type="checkbox"/>	19.0#
			16 x 36"	PWCT36	<input type="checkbox"/>	<input type="checkbox"/>	<input type="checkbox"/>	<input type="checkbox"/>	<input type="checkbox"/>	<input type="checkbox"/>	<input type="checkbox"/>	22.0#
		• Brackets include steel locking clips to prevent dislodgement	16 x 42"	PWCT42	<input type="checkbox"/>	<input type="checkbox"/>	<input type="checkbox"/>	<input type="checkbox"/>	<input type="checkbox"/>	<input type="checkbox"/>	<input type="checkbox"/>	25.0#
		• Countertops accept task light	16 x 48"	PWCT48	<input type="checkbox"/>	<input type="checkbox"/>	<input type="checkbox"/>	<input type="checkbox"/>	<input type="checkbox"/>	<input type="checkbox"/>	<input type="checkbox"/>	28.0#
			16 x 54"	PWCT54	<input type="checkbox"/>	<input type="checkbox"/>	<input type="checkbox"/>	<input type="checkbox"/>	<input type="checkbox"/>	<input type="checkbox"/>	<input type="checkbox"/>	31.0#
			16 x 60"	PWCT60	<input type="checkbox"/>	<input type="checkbox"/>	<input type="checkbox"/>	<input type="checkbox"/>	<input type="checkbox"/>	<input type="checkbox"/>	<input type="checkbox"/>	34.0#
			16 x 66"	PWCT66	<input type="checkbox"/>	<input type="checkbox"/>	<input type="checkbox"/>	<input type="checkbox"/>	<input type="checkbox"/>	<input type="checkbox"/>	<input type="checkbox"/>	37.0#
			16 x 72"	PWCT72	<input type="checkbox"/>	<input type="checkbox"/>	<input type="checkbox"/>	<input type="checkbox"/>	<input type="checkbox"/>	<input type="checkbox"/>	<input type="checkbox"/>	40.0#
			16 x 78"	PWCT78	<input type="checkbox"/>	<input type="checkbox"/>	<input type="checkbox"/>	<input type="checkbox"/>	<input type="checkbox"/>	<input type="checkbox"/>	<input type="checkbox"/>	43.0#
			16 x 84"	PWCT84	<input type="checkbox"/>	<input type="checkbox"/>	<input type="checkbox"/>	<input type="checkbox"/>	<input type="checkbox"/>	<input type="checkbox"/>	<input type="checkbox"/>	43.0#
 <p>P1NW - KD1-No Wood PWCT - Pass Through</p>	90° Corner Countertops		16 x 24"	PW9024	<input type="checkbox"/>	<input type="checkbox"/>	<input type="checkbox"/>	<input type="checkbox"/>	<input type="checkbox"/>	<input type="checkbox"/>	<input type="checkbox"/>	23.0#
		• For notch location of "LS, RS, BS", the notch has a grommet and will require a grommet color selection	2-piece standard 16 x 30"	PW9030	<input type="checkbox"/>	<input type="checkbox"/>	<input type="checkbox"/>	<input type="checkbox"/>	<input type="checkbox"/>	<input type="checkbox"/>	<input type="checkbox"/>	30.0#
		• Brackets include steel locking clips to prevent dislodgement	2-piece standard 16 x 36"	PW9036	<input type="checkbox"/>	<input type="checkbox"/>	<input type="checkbox"/>	<input type="checkbox"/>	<input type="checkbox"/>	<input type="checkbox"/>	<input type="checkbox"/>	37.0#
	• PL edge comes with two individual tops and are placed next to each other in field											
 <p>P1NW - KD1-No Wood PWCW - Pass Through</p>	Straight Countertops - ADA Height		16 x 24"	PWCTWC24	<input type="checkbox"/>	<input type="checkbox"/>	<input type="checkbox"/>	<input type="checkbox"/>	<input type="checkbox"/>	<input type="checkbox"/>	<input type="checkbox"/>	16.0#
		• For notch location of "LS, RS, BS", the notch has a grommet and will require a grommet color selection	16 x 30"	PWCTWC30	<input type="checkbox"/>	<input type="checkbox"/>	<input type="checkbox"/>	<input type="checkbox"/>	<input type="checkbox"/>	<input type="checkbox"/>	<input type="checkbox"/>	19.0#
			16 x 36"	PWCTWC36	<input type="checkbox"/>	<input type="checkbox"/>	<input type="checkbox"/>	<input type="checkbox"/>	<input type="checkbox"/>	<input type="checkbox"/>	<input type="checkbox"/>	22.0#
		• Brackets include steel locking clips to prevent dislodgement	16 x 42"	PWCTWC42	<input type="checkbox"/>	<input type="checkbox"/>	<input type="checkbox"/>	<input type="checkbox"/>	<input type="checkbox"/>	<input type="checkbox"/>	<input type="checkbox"/>	25.0#
		• Per the 2010 ADA and ICC A117.1, countertops do not extend more than 4 inches into a circulation path and meet the requirements for a clear floor space positioned for a parallel approach adjacent to the accessible counter.	16 x 48"	PWCTWC48	<input type="checkbox"/>	<input type="checkbox"/>	<input type="checkbox"/>	<input type="checkbox"/>	<input type="checkbox"/>	<input type="checkbox"/>	<input type="checkbox"/>	28.0#
			16 x 54"	PWCTWC54	<input type="checkbox"/>	<input type="checkbox"/>	<input type="checkbox"/>	<input type="checkbox"/>	<input type="checkbox"/>	<input type="checkbox"/>	<input type="checkbox"/>	31.0#
			16 x 60"	PWCTWC60	<input type="checkbox"/>	<input type="checkbox"/>	<input type="checkbox"/>	<input type="checkbox"/>	<input type="checkbox"/>	<input type="checkbox"/>	<input type="checkbox"/>	34.0#
			16 x 66"	PWCTWC66	<input type="checkbox"/>	<input type="checkbox"/>	<input type="checkbox"/>	<input type="checkbox"/>	<input type="checkbox"/>	<input type="checkbox"/>	<input type="checkbox"/>	37.0#
			16 x 72"	PWCTWC72	<input type="checkbox"/>	<input type="checkbox"/>	<input type="checkbox"/>	<input type="checkbox"/>	<input type="checkbox"/>	<input type="checkbox"/>	<input type="checkbox"/>	40.0#
			16 x 78"	PWCTWC78	<input type="checkbox"/>	<input type="checkbox"/>	<input type="checkbox"/>	<input type="checkbox"/>	<input type="checkbox"/>	<input type="checkbox"/>	<input type="checkbox"/>	43.0#
			16 x 84"	PWCTWC84	<input type="checkbox"/>	<input type="checkbox"/>	<input type="checkbox"/>	<input type="checkbox"/>	<input type="checkbox"/>	<input type="checkbox"/>	<input type="checkbox"/>	46.0#
 <p>P1NW - KD1-No Wood PWCW - Pass Through</p>	90° Countertops - ADA Height		16 x 24"	PWCTWC9024	<input type="checkbox"/>	<input type="checkbox"/>	<input type="checkbox"/>	<input type="checkbox"/>	<input type="checkbox"/>	<input type="checkbox"/>	<input type="checkbox"/>	23.0#
		• For notch location of "LS, RS, BS", the notch has a grommet and will require a grommet color selection	2-piece standard 16 x 30"	PWCTWC9030	<input type="checkbox"/>	<input type="checkbox"/>	<input type="checkbox"/>	<input type="checkbox"/>	<input type="checkbox"/>	<input type="checkbox"/>	<input type="checkbox"/>	30.0#
		• Brackets include steel locking clips to prevent dislodgement	2-piece standard 16 x 36"	PWCTWC9036	<input type="checkbox"/>	<input type="checkbox"/>	<input type="checkbox"/>	<input type="checkbox"/>	<input type="checkbox"/>	<input type="checkbox"/>	<input type="checkbox"/>	37.0#
	• PL edge comes with two individual tops and are placed next to each other in field											
	• Per the 2010 ADA and ICC A117.1, countertops do not extend more than 4 inches into a circulation path and meet the requirements for a clear floor space positioned for a parallel approach adjacent to the accessible counter.											

A **B** **C** **D** **E** **F** **G**

HOW TO ORDER

Indicate the following information on order form:

- Quantity of each item.
- Model number, including options. See "How To Build a Model Number".
- Any special service required.

Note: • The indicates that a choice is required.

- The absence of the indicates that no choice is required.
- Alpha-numeric characters in place of indicate that no other alternatives are available.

HOW TO BUILD A MODEL NUMBER

A Select basic model.

B Select notch location.

- S** - Standard
- LS** - Left notch for std trim
- RS** - Right notch for std trim
- BS** - Both notches for std trim
- LF** - Left notch for flat trim
- RF** - Right notch for flat trim
- BF** - Both notches for flat trim

For notch location of "LS, RS, BS", the notch has a grommet and will require a separate grommet color selection

C Select edge style.

- BN** - Flat vinyl T-edge
- 74P** - 74P edge

D Select surface finish.

Refer to the **Product Color Options** page in this catalog. Surface finish offerings are based on edge style selections.

E Select trim color.

Refer to the **Product Color Options** page in this catalog. Metallic finish not available.

F Select edge color.

Refer to the **Product Color Options** page in this catalog.

G Select grommet color.

For notch location of "LS, RS, BS", the notch has a grommet and will require a separate grommet color selection, otherwise there is no grommet color selection. Refer to the **Product Color Options** page in this catalog.

Worksurfaces

Mobile Teardrop/Mobile Semi-Circle

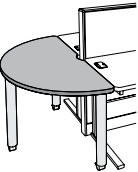
				MODEL NUMBER							Approx. Packaged Weight	
MODEL	Features	D x DIA	Basic Model	Edge Style	Height	Trim Color	Base	Surface Finish	Edge Color			
 <p>WMTFO-KD1-No Wood WMT-Pass Through</p>	<p>Mobile Teardrop Worksurface</p> <ul style="list-style-type: none"> 1-1/4" solid particleboard with high-pressure laminate Base consists of three 3" diameter metal support legs with adjustable chrome-plated glides as standard or optional casters Connects to end of 24" or 30" worksurface 29" height only with or without casters Pointed end is removed to accommodate corner of two PowerWorks panels 	24 X 45"	WMTPW2446	<input type="checkbox"/>		<input type="checkbox"/>	<input type="checkbox"/>	<input type="checkbox"/>	<input type="checkbox"/>	98.0#		
		30 X 55"	WMTPW3056	<input type="checkbox"/>		<input type="checkbox"/>	<input type="checkbox"/>	<input type="checkbox"/>	<input type="checkbox"/>	<input type="checkbox"/>	132.0#	
 <p>WMTFO - KD1-No Wood WMT - Pass Through</p>	<p>Mobile Semi-Circle Worksurface</p> <ul style="list-style-type: none"> 1-1/4" solid particleboard with high-pressure laminate Base consists of three 3" diameter metal support legs with adjustable chrome-plated glide as standard or optional casters Connects to end of 24" or 30" worksurface Notched in center for wire management 29" height only with or without casters Notch enables surface to wrap around end cap of PowerWorks® panel 51-1/2" diameter accommodates two 24" deep worksurfaces separated by a PowerWorks panel 63-1/2" diameter accommodates two 30" deep worksurfaces separated by a PowerWorks panel 	Std. 24 X 51-1/2"	WMSCPW52	<input type="checkbox"/>	9	<input type="checkbox"/>	<input type="checkbox"/>	<input type="checkbox"/>	<input type="checkbox"/>	69.0#		
		Std. 30 X 63-1/2"	WMSCPW64	<input type="checkbox"/>	9	<input type="checkbox"/>	<input type="checkbox"/>	<input type="checkbox"/>	<input type="checkbox"/>	<input type="checkbox"/>	88.0#	
		Flat 24 X 51-1/2"	WMSCFW52	<input type="checkbox"/>	9	<input type="checkbox"/>	<input type="checkbox"/>	<input type="checkbox"/>	<input type="checkbox"/>	<input type="checkbox"/>	69.0#	
		Flat 30 X 63-1/2"	WMSCFW64	<input type="checkbox"/>	9	<input type="checkbox"/>	<input type="checkbox"/>	<input type="checkbox"/>	<input type="checkbox"/>	<input type="checkbox"/>	88.0#	
				A	B	C	D	E	F	G		

HOW TO ORDER

Indicate the following information on order form:

- Quantity of each item.
- Model number, including options. See "How To Build a Model Number".
- Any special service required.

Note: • The indicates that a choice is required.

- The absence of the indicates that no choice is required.
- Alpha-numeric characters in place of indicate that no other alternatives are available.

HOW TO BUILD A MODEL NUMBER

A Select basic model.

B Select edge style.

BN - Flat vinyl T-edge
74P - 74P edge

C Select height.

9 - 29" high

D Select trim color (edge/grommet/support bracket).

Refer to the **Product Color Options** page in this catalog.

E Select base option.

G - Glides
C - Casters

F Select surface finish.

Refer to the **Product Color Options** page in this catalog. Surface finish offerings are based on edge style selections.

G Select edge color.

Refer to the **Product Color Options** page in this catalog. Edge color offerings are based on edge style selections.

Worksurfaces

Mobile Teardrop/Mobile Semi-Circle

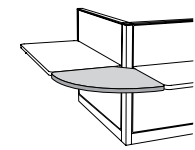

WCT.KIT.QUARTER - KD1-No
Wood

WCT - Pass Through

MODEL

Quarter Round Transitional Worksurface

- Two splice plates provided
- For use with fixed height workstations only
- Available with flat vinyl T-edge or 74P edge
- For use as conferencing corner
- Modesty panel not required
- Wireway option not available
- 24" surface has radius of 26-2/3" and 30" surface has a radius of 35"
- WQRP version has pointed end removed to accommodate corner of two PowerWorks panels

D x DIA

24 X 24" Dia for Panel
30 X 30" Dia for Panel

MODEL NUMBER

Basic
Model

Edge
Style

Surface
Finish

Edge
Color

Approx.
Packaged
Weight

WQRPW24

34.0#

WQRPW30

51.0#

A

B

C

D

HOW TO ORDER

Indicate the following information on order form:

1. Quantity of each item.
2. Model number, including options. See "How To Build a Model Number".
3. Any special service required.

Note: • The indicates that a choice is required.
• The absence of the indicates that no choice is required.
• Alpha-numeric characters in place of indicate that no other alternatives are available.

HOW TO BUILD A MODEL NUMBER

A Select basic model.

B Select edge style.

BN - Flat vinyl T-edge
74P - 74P edge

C Select surface finish.

Refer to the **Product Color Options** page in this catalog.
Surface finish offerings are based on edge style selections.

D Select edge color.

Refer to the **Product Color Options** page in this catalog.
Edge color offerings are based on edge style selections.

Worksurfaces

Worksurface Support Panel

MODEL	D x DIA	MODEL NUMBER					Approx. Packaged Weight
		Basic Model	Dir.	Surface Finish	Fabric Color	Edge Color	
 P1WS - KD1-No Wood PWSP - Pass Through Worksurface Support Panel (Fabric/Laminate) • Must specify left or right side version by adding /L (left) or /R (right) to product number • Support panel provides additional worksurface support in extensive worksurface loading applications • Mounts to panel and worksurface • Adjustable glides provide leveling capability • 26" worksurface height equals 24-7/8" panel height • 29" worksurface height equals 27-7/8" panel height	24 x 26"	PWSSP2426/BN	<input type="checkbox"/>	<input type="checkbox"/>	<input type="checkbox"/>	<input type="checkbox"/>	15.0#
	24 x 29"	PWSSP2429/BN	<input type="checkbox"/>	<input type="checkbox"/>	<input type="checkbox"/>	<input type="checkbox"/>	16.0#
	30 x 26"	PWSSP3026/BN	<input type="checkbox"/>	<input type="checkbox"/>	<input type="checkbox"/>	<input type="checkbox"/>	17.0#
	30 x 29"	PWSSP3029/BN	<input type="checkbox"/>	<input type="checkbox"/>	<input type="checkbox"/>	<input type="checkbox"/>	18.0#

A
B
C
D
E

HOW TO ORDER

Indicate the following information on order form:

1. Quantity of each item.
2. Model number, including options. See "How To Build a Model Number".
3. Any special service required.

Note: • The indicates that a choice is required.

- The absence of the indicates that no choice is required.
- Alpha-numeric characters in place of indicate that no other alternatives are available.

HOW TO BUILD A MODEL NUMBER

A Select basic model.

B Select surface direction.

- DL** - Direction left
- DR** - Direction right

C Select surface finish.

Refer to the **Product Color Options** page in this catalog.
Surface finish offerings are based on edge style selections.

D Select fabric color.

E Select edge color.

Refer to the **Product Color Options** page in this catalog.

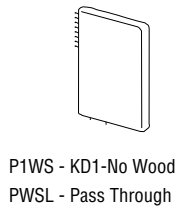

MODEL

D x DIA

MODEL NUMBER

Basic Model

Dir.

Edge Style

Surface Finish

Edge Color

Approx. Packaged Weight

Worksurface Support Panel (Laminate Both Sides)

- Must specify left or right side version by adding /L (left) or /R (right) to product number
- Support panel provides additional worksurface support in extensive worksurface loading applications
- Mounts to panel and worksurface
- Adjustable glides provide leveling capability
- 26" worksurface height equals 24-7/8" panel height
- 29" worksurface height equals 27-7/8" panel height

MODEL	D x DIA	Basic Model	Dir.	Edge Style	Surface Finish	Edge Color	Approx. Packaged Weight
	24 x 26"	PWSSL2426	<input type="checkbox"/>	<input type="checkbox"/>	<input type="checkbox"/>	<input type="checkbox"/>	15.0#
	24 x 29"	PWSSL2429	<input type="checkbox"/>	<input type="checkbox"/>	<input type="checkbox"/>	<input type="checkbox"/>	16.0#
	30 x 26"	PWSSL3026	<input type="checkbox"/>	<input type="checkbox"/>	<input type="checkbox"/>	<input type="checkbox"/>	17.0#
	30 x 29"	PWSSL3029	<input type="checkbox"/>	<input type="checkbox"/>	<input type="checkbox"/>	<input type="checkbox"/>	18.0#

A **B** **C** **D** **E**

HOW TO ORDER

Indicate the following information on order form:

1. Quantity of each item.
2. Model number, including options. See "How To Build a Model Number".
3. Any special service required.

- Note:
- The indicates that a choice is required.
 - The absence of the indicates that no choice is required.
 - Alpha-numeric characters in place of indicate that no other alternatives are available.

HOW TO BUILD A MODEL NUMBER

- A** Select basic model.
- B** Select surface direction.
DL _____ - Direction left
DR _____ - Direction right
- C** Select surface finish.
Refer to the **Product Color Options** page in this catalog.
Surface finish offerings are based on edge style selections.
- D** Select fabric color.
- E** Select edge color.
Refer to the **Product Color Options** page in this catalog.

Worksurface Accessories

Worksurface Accessories

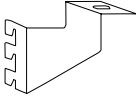
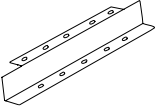
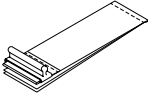
	MODEL	Features	W x D x H	MODEL NUMBER		Approx. Packaged Weight
				Basic Model	Trim Color	
 HRDPT	Grommets - Field-Installed	Inside - 2-3/4", Outside - 3"		WSG		1.0#
 HRDPT	Worksurface Support Bracket		3 x 4"	PWSB.L		1.0#
			3 x 4"	PWSB.R		1.0#
 HRDPT	Worksurface Vertical Filler		3 x 24"	WSVF.24		3.0#
			3 x 30"	WSVF.30		3.0#
 HRDPT	Worksurface Wire Manager	W - 2", D - 2-1/2"		WWM		1.0#

A

B

HOW TO ORDER

Indicate the following information on order form:

1. Quantity of each item.
2. Model number, including options. See "How To Build a Model Number".
3. Any special service required.

Note: • The indicates that a choice is required.

- The absence of the indicates that no choice is required.
- Alpha-numeric characters in place of indicate that no other alternatives are available.

HOW TO BUILD A MODEL NUMBER

A Select basic model.

B Select trim color.
Refer to the **Product Color Options** page in this catalog.
Metallic finish not available.

HOW TO ORDER

Indicate the following information on order form:

1. Quantity of each item.
2. Model number, including options. See "How To Build a Model Number".
3. Any special service required.

Note:

- The indicates that a choice is required.
- The absence of the indicates that no choice is required.
- Alpha-numeric characters in place of indicate that no other alternatives are available.

Universal Storage and Accessories

Overhead Storage

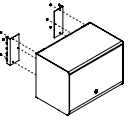
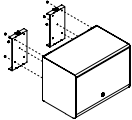
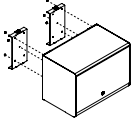
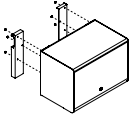
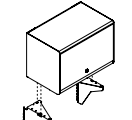
	MODEL	W x H x D	MODEL NUMBER				Approx. Packaged Weight
			Basic Model	Assembly	Paint Color	Key Option	
 PRDS	Steel Door Overhead Cabinet-On-Module <ul style="list-style-type: none"> On-Module overheads (PM) mount into slots in vertical posts. Overheads must be same width as panel mounted to. Does not require a 12" tile for mounting. Allows for vertical adjustment in 1" increments 	24 x 16-1/2 x 14-1/2"	PRDS24/WW/PM	<input type="checkbox"/>	<input type="checkbox"/>	<input type="checkbox"/>	32.0#
		30 x 16-1/2 x 14-1/2"	PRDS30/WW/PM	<input type="checkbox"/>	<input type="checkbox"/>	<input type="checkbox"/>	36.0#
		36 x 16-1/2 x 14-1/2"	PRDS36/WW/PM	<input type="checkbox"/>	<input type="checkbox"/>	<input type="checkbox"/>	40.0#
		42 x 16-1/2 x 14-1/2"	PRDS42/WW/PM	<input type="checkbox"/>	<input type="checkbox"/>	<input type="checkbox"/>	44.0#
		48 x 16-1/2 x 14-1/2"	PRDS48/WW/PM	<input type="checkbox"/>	<input type="checkbox"/>	<input type="checkbox"/>	49.0#
		54 x 16-1/2 x 14-1/2"	PRDS54/WW/PM	<input type="checkbox"/>	<input type="checkbox"/>	<input type="checkbox"/>	53.0#
		60 x 16-1/2 x 14-1/2"	PRDS60/WW/PM	<input type="checkbox"/>	<input type="checkbox"/>	<input type="checkbox"/>	57.0#
 PRDS	Steel Door Overhead Cabinet-Off-Module <ul style="list-style-type: none"> Off-Module overheads (OM12) for PowerWorks® mount into an integral track in the horizontal rail. Allows shelf to slide along track. Requires a 12" tile for mounting (i.e. must be a half or fully segmented panel) 	24 x 16-1/2 x 14-1/2"	PRDS24/WW/OM12	<input type="checkbox"/>	<input type="checkbox"/>	<input type="checkbox"/>	32.0#
		30 x 16-1/2 x 14-1/2"	PRDS30/WW/OM12	<input type="checkbox"/>	<input type="checkbox"/>	<input type="checkbox"/>	36.0#
		36 x 16-1/2 x 14-1/2"	PRDS36/WW/OM12	<input type="checkbox"/>	<input type="checkbox"/>	<input type="checkbox"/>	40.0#
		42 x 16-1/2 x 14-1/2"	PRDS42/WW/OM12	<input type="checkbox"/>	<input type="checkbox"/>	<input type="checkbox"/>	44.0#
		48 x 16-1/2 x 14-1/2"	PRDS48/WW/OM12	<input type="checkbox"/>	<input type="checkbox"/>	<input type="checkbox"/>	49.0#
		54 x 16-1/2 x 14-1/2"	PRDS54/WW/OM12	<input type="checkbox"/>	<input type="checkbox"/>	<input type="checkbox"/>	53.0#
		60 x 16-1/2 x 14-1/2"	PRDS60/WW/OM12	<input type="checkbox"/>	<input type="checkbox"/>	<input type="checkbox"/>	57.0#
 PRDS	Steel Door Cabinet-Off-Module <ul style="list-style-type: none"> Off-Module overheads (OM18) for PowerWorks® mount into an integral track in the horizontal rail. Allows shelf to slide along track. Requires a 18" tile (OM18) for mounting (i.e. must be a half or fully segmented panel) 	24 x 16-1/2 x 14-1/2"	PRDS24/WW/OM18	<input type="checkbox"/>	<input type="checkbox"/>	<input type="checkbox"/>	32.0#
		30 x 16-1/2 x 14-1/2"	PRDS30/WW/OM18	<input type="checkbox"/>	<input type="checkbox"/>	<input type="checkbox"/>	36.0#
		36 x 16-1/2 x 14-1/2"	PRDS36/WW/OM18	<input type="checkbox"/>	<input type="checkbox"/>	<input type="checkbox"/>	40.0#
		42 x 16-1/2 x 14-1/2"	PRDS42/WW/OM18	<input type="checkbox"/>	<input type="checkbox"/>	<input type="checkbox"/>	44.0#
		48 x 16-1/2 x 14-1/2"	PRDS48/WW/OM18	<input type="checkbox"/>	<input type="checkbox"/>	<input type="checkbox"/>	49.0#
		54 x 16-1/2 x 14-1/2"	PRDS54/WW/OM18	<input type="checkbox"/>	<input type="checkbox"/>	<input type="checkbox"/>	53.0#
		60 x 16-1/2 x 14-1/2"	PRDS60/WW/OM18	<input type="checkbox"/>	<input type="checkbox"/>	<input type="checkbox"/>	57.0#
 PRDS	Steel Door Overhead Cabinet-Load Bar Mount <ul style="list-style-type: none"> Load Bar mount overheads (LB) for PowerWorks® hang from an externally mounted load bar Load Bar purchased separately 	24 x 16-1/2 x 14-1/2"	PRDS24/WW/LB	<input type="checkbox"/>	<input type="checkbox"/>	<input type="checkbox"/>	32.0#
		30 x 16-1/2 x 14-1/2"	PRDS30/WW/LB	<input type="checkbox"/>	<input type="checkbox"/>	<input type="checkbox"/>	36.0#
		36 x 16-1/2 x 14-1/2"	PRDS36/WW/LB	<input type="checkbox"/>	<input type="checkbox"/>	<input type="checkbox"/>	40.0#
		42 x 16-1/2 x 14-1/2"	PRDS42/WW/LB	<input type="checkbox"/>	<input type="checkbox"/>	<input type="checkbox"/>	44.0#
		48 x 16-1/2 x 14-1/2"	PRDS48/WW/LB	<input type="checkbox"/>	<input type="checkbox"/>	<input type="checkbox"/>	49.0#
		54 x 16-1/2 x 14-1/2"	PRDS54/WW/LB	<input type="checkbox"/>	<input type="checkbox"/>	<input type="checkbox"/>	53.0#
		60 x 16-1/2 x 14-1/2"	PRDS60/WW/LB	<input type="checkbox"/>	<input type="checkbox"/>	<input type="checkbox"/>	57.0#
 PRDS	Steel Door Overhead Cabinet-Upmount <ul style="list-style-type: none"> Upmount brackets position the storage component on a 54" high panel to the same height as on 66" high panels On a 54" high panel, clearance between the cabinet and worksurface is 20" On a 48" high panel, clearance between the cabinet and worksurface is 14" 	24 x 16-1/2 x 14-1/2"	PRDS24/WW/UM	<input type="checkbox"/>	<input type="checkbox"/>	<input type="checkbox"/>	32.0#
		30 x 16-1/2 x 14-1/2"	PRDS30/WW/UM	<input type="checkbox"/>	<input type="checkbox"/>	<input type="checkbox"/>	36.0#
		36 x 16-1/2 x 14-1/2"	PRDS36/WW/UM	<input type="checkbox"/>	<input type="checkbox"/>	<input type="checkbox"/>	40.0#
		42 x 16-1/2 x 14-1/2"	PRDS42/WW/UM	<input type="checkbox"/>	<input type="checkbox"/>	<input type="checkbox"/>	44.0#
		48 x 16-1/2 x 14-1/2"	PRDS48/WW/UM	<input type="checkbox"/>	<input type="checkbox"/>	<input type="checkbox"/>	49.0#
		54 x 16-1/2 x 14-1/2"	PRDS54/WW/UM	<input type="checkbox"/>	<input type="checkbox"/>	<input type="checkbox"/>	53.0#
		60 x 16-1/2 x 14-1/2"	PRDS60/WW/UM	<input type="checkbox"/>	<input type="checkbox"/>	<input type="checkbox"/>	57.0#

A

B

C

D

HOW TO ORDER

Indicate the following information on order form:

- Quantity of each item.
- Model number, including options. See "How To Build a Model Number".
- Any special service required.

Note: • The indicates that a choice is required.

- The absence of the indicates that no choice is required.

- Alpha-numeric characters in place of indicate that no other alternatives are available.

HOW TO BUILD A MODEL NUMBER

- A** Select basic model.

- B** Select assembly.

F - Fully Assembled
 U - Unassembled

- C** Select paint color.

Refer to the **Product Color Options** page in this catalog.

- D** Select key alike.

KA - Key alike
 KS - Key standard
 NLC - No lock core

Universal Storage and Accessories

Overhead Storage

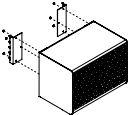
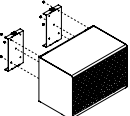
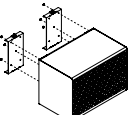
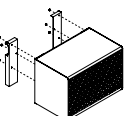
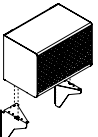
	MODEL	W x H x D	MODEL NUMBER					Approx. Packaged Weight
			Basic Model	Assembly	Paint Color	Fabric Color	Key Option	
 PRDF	Fabric Door Overhead Cabinet-On-Module • On-Module overheads (PM) mount into slots in vertical posts. Overheads must be same width as panel mounted to. Does not require a 12" tile for mounting. Allows for vertical adjustment in 1" increments	24 x 16-1/2 x 14-1/2"	PRDF24/WW/PM	<input type="checkbox"/>	<input type="checkbox"/>	<input type="checkbox"/>	<input type="checkbox"/>	32.0#
		30 x 16-1/2 x 14-1/2"	PRDF30/WW/PM	<input type="checkbox"/>	<input type="checkbox"/>	<input type="checkbox"/>	<input type="checkbox"/>	36.0#
		36 x 16-1/2 x 14-1/2"	PRDF36/WW/PM	<input type="checkbox"/>	<input type="checkbox"/>	<input type="checkbox"/>	<input type="checkbox"/>	40.0#
		42 x 16-1/2 x 14-1/2"	PRDF42/WW/PM	<input type="checkbox"/>	<input type="checkbox"/>	<input type="checkbox"/>	<input type="checkbox"/>	44.0#
		48 x 16-1/2 x 14-1/2"	PRDF48/WW/PM	<input type="checkbox"/>	<input type="checkbox"/>	<input type="checkbox"/>	<input type="checkbox"/>	49.0#
		54 x 16-1/2 x 14-1/2"	PRDF54/WW/PM	<input type="checkbox"/>	<input type="checkbox"/>	<input type="checkbox"/>	<input type="checkbox"/>	53.0#
 PRDF	Fabric Door Overhead Cabinet-Off-Module • Off-Module overheads (OM12) for PowerWorks® mount into an integral track in the horizontal rail. Allows shelf to slide along track. Requires a 12" tile for mounting (i.e. must be a half or fully segmented panel)	24 x 16-1/2 x 14-1/2"	PRDF24/WW/OM12	<input type="checkbox"/>	<input type="checkbox"/>	<input type="checkbox"/>	<input type="checkbox"/>	32.0#
		30 x 16-1/2 x 14-1/2"	PRDF30/WW/OM12	<input type="checkbox"/>	<input type="checkbox"/>	<input type="checkbox"/>	<input type="checkbox"/>	36.0#
		36 x 16-1/2 x 14-1/2"	PRDF36/WW/OM12	<input type="checkbox"/>	<input type="checkbox"/>	<input type="checkbox"/>	<input type="checkbox"/>	40.0#
		42 x 16-1/2 x 14-1/2"	PRDF42/WW/OM12	<input type="checkbox"/>	<input type="checkbox"/>	<input type="checkbox"/>	<input type="checkbox"/>	44.0#
		48 x 16-1/2 x 14-1/2"	PRDF48/WW/OM12	<input type="checkbox"/>	<input type="checkbox"/>	<input type="checkbox"/>	<input type="checkbox"/>	49.0#
		54 x 16-1/2 x 14-1/2"	PRDF54/WW/OM12	<input type="checkbox"/>	<input type="checkbox"/>	<input type="checkbox"/>	<input type="checkbox"/>	53.0#
 PRDF	Fabric Door Overhead Cabinet-Off-Module • Off-Module overheads (OM18) for PowerWorks® mount into an integral track in the horizontal rail. Allows shelf to slide along track. Requires a 18" tile (OM18) for mounting (i.e. must be a half or fully segmented panel)	24 x 16-1/2 x 14-1/2"	PRDF24/WW/OM18	<input type="checkbox"/>	<input type="checkbox"/>	<input type="checkbox"/>	<input type="checkbox"/>	32.0#
		30 x 16-1/2 x 14-1/2"	PRDF30/WW/OM18	<input type="checkbox"/>	<input type="checkbox"/>	<input type="checkbox"/>	<input type="checkbox"/>	36.0#
		36 x 16-1/2 x 14-1/2"	PRDF36/WW/OM18	<input type="checkbox"/>	<input type="checkbox"/>	<input type="checkbox"/>	<input type="checkbox"/>	40.0#
		42 x 16-1/2 x 14-1/2"	PRDF42/WW/OM18	<input type="checkbox"/>	<input type="checkbox"/>	<input type="checkbox"/>	<input type="checkbox"/>	44.0#
		48 x 16-1/2 x 14-1/2"	PRDF48/WW/OM18	<input type="checkbox"/>	<input type="checkbox"/>	<input type="checkbox"/>	<input type="checkbox"/>	49.0#
		54 x 16-1/2 x 14-1/2"	PRDF54/WW/OM18	<input type="checkbox"/>	<input type="checkbox"/>	<input type="checkbox"/>	<input type="checkbox"/>	53.0#
 PRDF	Fabric Door Overhead Cabinet-Load Bar Mount • Load Bar mount overheads (LB) for PowerWorks® hang from an externally mounted load bar • Load Bar purchased separately	24 x 16-1/2 x 14-1/2"	PRDF24/WW/LB	<input type="checkbox"/>	<input type="checkbox"/>	<input type="checkbox"/>	<input type="checkbox"/>	32.0#
		30 x 16-1/2 x 14-1/2"	PRDF30/WW/LB	<input type="checkbox"/>	<input type="checkbox"/>	<input type="checkbox"/>	<input type="checkbox"/>	36.0#
		36 x 16-1/2 x 14-1/2"	PRDF36/WW/LB	<input type="checkbox"/>	<input type="checkbox"/>	<input type="checkbox"/>	<input type="checkbox"/>	40.0#
		42 x 16-1/2 x 14-1/2"	PRDF42/WW/LB	<input type="checkbox"/>	<input type="checkbox"/>	<input type="checkbox"/>	<input type="checkbox"/>	44.0#
		48 x 16-1/2 x 14-1/2"	PRDF48/WW/LB	<input type="checkbox"/>	<input type="checkbox"/>	<input type="checkbox"/>	<input type="checkbox"/>	49.0#
		54 x 16-1/2 x 14-1/2"	PRDF54/WW/LB	<input type="checkbox"/>	<input type="checkbox"/>	<input type="checkbox"/>	<input type="checkbox"/>	53.0#
 PRDF	Fabric Door Overhead Cabinet-Upmount • Upmount brackets position the storage component on a 54" high panel to the same height as on 66" high panels • On a 54" high panel, clearance between the cabinet and worksurface is 20" • On a 48" high panel, clearance between the cabinet and worksurface is 14"	24 x 16-1/2 x 14-1/2"	PRDF24/WW/UM	<input type="checkbox"/>	<input type="checkbox"/>	<input type="checkbox"/>	<input type="checkbox"/>	32.0#
		30 x 16-1/2 x 14-1/2"	PRDF30/WW/UM	<input type="checkbox"/>	<input type="checkbox"/>	<input type="checkbox"/>	<input type="checkbox"/>	36.0#
		36 x 16-1/2 x 14-1/2"	PRDF36/WW/UM	<input type="checkbox"/>	<input type="checkbox"/>	<input type="checkbox"/>	<input type="checkbox"/>	40.0#
		42 x 16-1/2 x 14-1/2"	PRDF42/WW/UM	<input type="checkbox"/>	<input type="checkbox"/>	<input type="checkbox"/>	<input type="checkbox"/>	44.0#
		48 x 16-1/2 x 14-1/2"	PRDF48/WW/UM	<input type="checkbox"/>	<input type="checkbox"/>	<input type="checkbox"/>	<input type="checkbox"/>	49.0#
		54 x 16-1/2 x 14-1/2"	PRDF54/WW/UM	<input type="checkbox"/>	<input type="checkbox"/>	<input type="checkbox"/>	<input type="checkbox"/>	53.0#
		60 x 16-1/2 x 14-1/2"	PRDF60/WW/UM	<input type="checkbox"/>	<input type="checkbox"/>	<input type="checkbox"/>	<input type="checkbox"/>	57.0#

A **B** **C** **D** **E**

HOW TO ORDER

Indicate the following information on order form:

- Quantity of each item.
- Model number, including options. See "How To Build a Model Number".
- Any special service required.

Note: • The indicates that a choice is required.
 • The absence of the indicates that no choice is required.
 • Alpha-numeric characters in place of indicate that no other alternatives are available.

HOW TO BUILD A MODEL NUMBER

- A** Select basic model.

F	- Fully Assembled
U	- Unassembled
- B** Select assembly.
- C** Select paint color.
 Refer to the **Product Color Options** page in this catalog.
- D** Select fabric color.
- E** Select key alike.

KA	- Key alike
KS	- Key standard
NLC	- No lock core

Universal Storage and Accessories

Overhead Storage

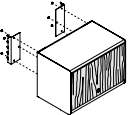
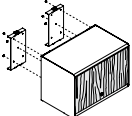
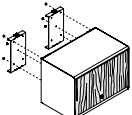
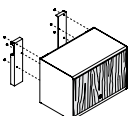
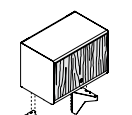
	MODEL	W x H x D	MODEL NUMBER					Approx. Packaged Weight
			Basic Model	Assembly	Paint Color	Laminate Color	Key Option	
 PRDL	Laminate Door Overhead Cabinet-On-Module (PM) • On-Module overheads mount into slots in vertical posts. Overheads must be same width as panel mounted to. Does not require 12" tile for mounting. Allows for vertical adjustment in 1" increments	24 x 16-1/2 x 14-1/2"	PRDL24/WW/PM	<input type="checkbox"/>	<input type="checkbox"/>	<input type="checkbox"/>	<input type="checkbox"/>	32.0#
		30 x 16-1/2 x 14-1/2"	PRDL30/WW/PM	<input type="checkbox"/>	<input type="checkbox"/>	<input type="checkbox"/>	<input type="checkbox"/>	36.0#
		36 x 16-1/2 x 14-1/2"	PRDL36/WW/PM	<input type="checkbox"/>	<input type="checkbox"/>	<input type="checkbox"/>	<input type="checkbox"/>	40.0#
		42 x 16-1/2 x 14-1/2"	PRDL42/WW/PM	<input type="checkbox"/>	<input type="checkbox"/>	<input type="checkbox"/>	<input type="checkbox"/>	44.0#
		48 x 16-1/2 x 14-1/2"	PRDL48/WW/PM	<input type="checkbox"/>	<input type="checkbox"/>	<input type="checkbox"/>	<input type="checkbox"/>	48.0#
		54 x 16-1/2 x 14-1/2"	PRDL54/WW/PM	<input type="checkbox"/>	<input type="checkbox"/>	<input type="checkbox"/>	<input type="checkbox"/>	53.0#
		60 x 16-1/2 x 14-1/2"	PRDL60/WW/PM	<input type="checkbox"/>	<input type="checkbox"/>	<input type="checkbox"/>	<input type="checkbox"/>	57.0#
 PRDL	Laminate Door Overhead Cabinet-Off-Module (OM12) • Off-Module overheads for PowerWorks® mount into an integral track in the horizontal rail. Allows shelf to slide along track. Requires 12" tile for mounting (i.e. must be a half or fully segmented panel)	24 x 16-1/2 x 14-1/2"	PRDL24/WW/OM12	<input type="checkbox"/>	<input type="checkbox"/>	<input type="checkbox"/>	<input type="checkbox"/>	32.0#
		30 x 16-1/2 x 14-1/2"	PRDL30/WW/OM12	<input type="checkbox"/>	<input type="checkbox"/>	<input type="checkbox"/>	<input type="checkbox"/>	36.0#
		36 x 16-1/2 x 14-1/2"	PRDL36/WW/OM12	<input type="checkbox"/>	<input type="checkbox"/>	<input type="checkbox"/>	<input type="checkbox"/>	40.0#
		42 x 16-1/2 x 14-1/2"	PRDL42/WW/OM12	<input type="checkbox"/>	<input type="checkbox"/>	<input type="checkbox"/>	<input type="checkbox"/>	44.0#
		48 x 16-1/2 x 14-1/2"	PRDL48/WW/OM12	<input type="checkbox"/>	<input type="checkbox"/>	<input type="checkbox"/>	<input type="checkbox"/>	48.0#
		54 x 16-1/2 x 14-1/2"	PRDL54/WW/OM12	<input type="checkbox"/>	<input type="checkbox"/>	<input type="checkbox"/>	<input type="checkbox"/>	53.0#
		60 x 16-1/2 x 14-1/2"	PRDL60/WW/OM12	<input type="checkbox"/>	<input type="checkbox"/>	<input type="checkbox"/>	<input type="checkbox"/>	57.0#
 PRDL	Laminate Door Overhead Cabinet-Off-Module (OM18) • Off-Module overheads for PowerWorks® mount into an integral track in the horizontal rail. Allows shelf to slide along track. Requires 18" tile for mounting (i.e. must be a half or fully segmented panel)	24 x 16-1/2 x 14-1/2"	PRDL24/WW/OM18	<input type="checkbox"/>	<input type="checkbox"/>	<input type="checkbox"/>	<input type="checkbox"/>	32.0#
		30 x 16-1/2 x 14-1/2"	PRDL30/WW/OM18	<input type="checkbox"/>	<input type="checkbox"/>	<input type="checkbox"/>	<input type="checkbox"/>	36.0#
		36 x 16-1/2 x 14-1/2"	PRDL36/WW/OM18	<input type="checkbox"/>	<input type="checkbox"/>	<input type="checkbox"/>	<input type="checkbox"/>	40.0#
		42 x 16-1/2 x 14-1/2"	PRDL42/WW/OM18	<input type="checkbox"/>	<input type="checkbox"/>	<input type="checkbox"/>	<input type="checkbox"/>	44.0#
		48 x 16-1/2 x 14-1/2"	PRDL48/WW/OM18	<input type="checkbox"/>	<input type="checkbox"/>	<input type="checkbox"/>	<input type="checkbox"/>	48.0#
		54 x 16-1/2 x 14-1/2"	PRDL54/WW/OM18	<input type="checkbox"/>	<input type="checkbox"/>	<input type="checkbox"/>	<input type="checkbox"/>	53.0#
		60 x 16-1/2 x 14-1/2"	PRDL60/WW/OM18	<input type="checkbox"/>	<input type="checkbox"/>	<input type="checkbox"/>	<input type="checkbox"/>	57.0#
 PRDL	Laminate Door Overhead Cabinet-Load Bar Mount (LB) • Load Bar mount overheads (LB) for PowerWorks® hang from an externally mounted load bar • Load Bar purchased separately	24 x 16-1/2 x 14-1/2"	PRDL24/WW/LB	<input type="checkbox"/>	<input type="checkbox"/>	<input type="checkbox"/>	<input type="checkbox"/>	32.0#
		30 x 16-1/2 x 14-1/2"	PRDL30/WW/LB	<input type="checkbox"/>	<input type="checkbox"/>	<input type="checkbox"/>	<input type="checkbox"/>	36.0#
		36 x 16-1/2 x 14-1/2"	PRDL36/WW/LB	<input type="checkbox"/>	<input type="checkbox"/>	<input type="checkbox"/>	<input type="checkbox"/>	40.0#
		42 x 16-1/2 x 14-1/2"	PRDL42/WW/LB	<input type="checkbox"/>	<input type="checkbox"/>	<input type="checkbox"/>	<input type="checkbox"/>	44.0#
		48 x 16-1/2 x 14-1/2"	PRDL48/WW/LB	<input type="checkbox"/>	<input type="checkbox"/>	<input type="checkbox"/>	<input type="checkbox"/>	48.0#
		54 x 16-1/2 x 14-1/2"	PRDL54/WW/LB	<input type="checkbox"/>	<input type="checkbox"/>	<input type="checkbox"/>	<input type="checkbox"/>	53.0#
		60 x 16-1/2 x 14-1/2"	PRDL60/WW/LB	<input type="checkbox"/>	<input type="checkbox"/>	<input type="checkbox"/>	<input type="checkbox"/>	57.0#
 PRDL	Laminate Door Overhead Cabinet-Upmount • Upmount brackets position the storage component on a 54" high panel to the same height as on 66" high panels • On a 54" high panel, clearance between the cabinet and worksurface is 20" • On a 48" high panel, clearance between the cabinet and worksurface is 14"	24 x 16-1/2 x 14-1/2"	PRDL24/WW/UM	<input type="checkbox"/>	<input type="checkbox"/>	<input type="checkbox"/>	<input type="checkbox"/>	32.0#
		30 x 16-1/2 x 14-1/2"	PRDL30/WW/UM	<input type="checkbox"/>	<input type="checkbox"/>	<input type="checkbox"/>	<input type="checkbox"/>	36.0#
		36 x 16-1/2 x 14-1/2"	PRDL36/WW/UM	<input type="checkbox"/>	<input type="checkbox"/>	<input type="checkbox"/>	<input type="checkbox"/>	40.0#
		42 x 16-1/2 x 14-1/2"	PRDL42/WW/UM	<input type="checkbox"/>	<input type="checkbox"/>	<input type="checkbox"/>	<input type="checkbox"/>	44.0#
		48 x 16-1/2 x 14-1/2"	PRDL48/WW/UM	<input type="checkbox"/>	<input type="checkbox"/>	<input type="checkbox"/>	<input type="checkbox"/>	48.0#
		54 x 16-1/2 x 14-1/2"	PRDL54/WW/UM	<input type="checkbox"/>	<input type="checkbox"/>	<input type="checkbox"/>	<input type="checkbox"/>	53.0#
		60 x 16-1/2 x 14-1/2"	PRDL60/WW/UM	<input type="checkbox"/>	<input type="checkbox"/>	<input type="checkbox"/>	<input type="checkbox"/>	57.0#

A

B

C

D

E

HOW TO ORDER

Indicate the following information on order form:

- Quantity of each item.
- Model number, including options. See "How To Build a Model Number".
- Any special service required.

Note: • The indicates that a choice is required.

- The absence of the indicates that no choice is required.
- Alpha-numeric characters in place of indicate that no other alternatives are available.

HOW TO BUILD A MODEL NUMBER

A Select basic model.

B Select assembly.

F - Fully Assembled
U - Unassembled

C Select paint color.

Refer to the **Product Color Options** page in this catalog.

D Select laminate color.

Refer to the **Product Color Options** page in this catalog.

E Select key alike.

KA - Key alike
KS - Key standard
NLC - No lock core

Universal Storage and Accessories

Overhead Storage

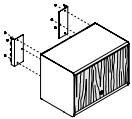
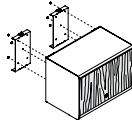
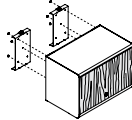
			MODEL NUMBER					Approx. Packaged Weight
MODEL	W x H x D	Basic Model	Assembly	Paint Color	Veneer Color	Key Option		
 <p>PRDV</p> <p>Veneer Door Overhead Cabinet-On-Module (PM)</p> <ul style="list-style-type: none"> On-Module overheads mount into slots in vertical posts. Overheads must be same width as panel mounted to. Does not require 12" tile for mounting. Allows for vertical adjustment in 1" increments 	24 x 16-1/2 x 14-1/2"	PRDV24/WW/PM	<input type="checkbox"/>	<input type="checkbox"/>	<input type="checkbox"/>	<input type="checkbox"/>	34.0#	
	30 x 16-1/2 x 14-1/2"	PRDV30/WW/PM	<input type="checkbox"/>	<input type="checkbox"/>	<input type="checkbox"/>	<input type="checkbox"/>	36.0#	
	36 x 16-1/2 x 14-1/2"	PRDV36/WW/PM	<input type="checkbox"/>	<input type="checkbox"/>	<input type="checkbox"/>	<input type="checkbox"/>	44.0#	
	42 x 16-1/2 x 14-1/2"	PRDV42/WW/PM	<input type="checkbox"/>	<input type="checkbox"/>	<input type="checkbox"/>	<input type="checkbox"/>	49.0#	
	48 x 16-1/2 x 14-1/2"	PRDV48/WW/PM	<input type="checkbox"/>	<input type="checkbox"/>	<input type="checkbox"/>	<input type="checkbox"/>	54.0#	
	54 x 16-1/2 x 14-1/2"	PRDV54/WW/PM	<input type="checkbox"/>	<input type="checkbox"/>	<input type="checkbox"/>	<input type="checkbox"/>	60.0#	
	60 x 16-1/2 x 14-1/2"	PRDV60/WW/PM	<input type="checkbox"/>	<input type="checkbox"/>	<input type="checkbox"/>	<input type="checkbox"/>	64.0#	
 <p>PRDV</p> <p>Veneer Door Overhead Cabinet-Off-Module (OM12)</p> <ul style="list-style-type: none"> Off-Module overheads for PowerWorks® mount into an integral track in the horizontal rail. Allows shelf to slide along track. Requires 12" tile for mounting (i.e. must be a half or fully segmented panel) 	24 x 16-1/2 x 14-1/2"	PRDV24/WW/OM12	<input type="checkbox"/>	<input type="checkbox"/>	<input type="checkbox"/>	<input type="checkbox"/>	34.0#	
	30 x 16-1/2 x 14-1/2"	PRDV30/WW/OM12	<input type="checkbox"/>	<input type="checkbox"/>	<input type="checkbox"/>	<input type="checkbox"/>	36.0#	
	36 x 16-1/2 x 14-1/2"	PRDV36/WW/OM12	<input type="checkbox"/>	<input type="checkbox"/>	<input type="checkbox"/>	<input type="checkbox"/>	44.0#	
	42 x 16-1/2 x 14-1/2"	PRDV42/WW/OM12	<input type="checkbox"/>	<input type="checkbox"/>	<input type="checkbox"/>	<input type="checkbox"/>	49.0#	
	48 x 16-1/2 x 14-1/2"	PRDV48/WW/OM12	<input type="checkbox"/>	<input type="checkbox"/>	<input type="checkbox"/>	<input type="checkbox"/>	54.0#	
	54 x 16-1/2 x 14-1/2"	PRDV54/WW/OM12	<input type="checkbox"/>	<input type="checkbox"/>	<input type="checkbox"/>	<input type="checkbox"/>	60.0#	
	60 x 16-1/2 x 14-1/2"	PRDV60/WW/OM12	<input type="checkbox"/>	<input type="checkbox"/>	<input type="checkbox"/>	<input type="checkbox"/>	64.0#	
 <p>PRDV</p> <p>Veneer Door Overhead Cabinet-Off-Module (OM18)</p> <ul style="list-style-type: none"> Off-Module overheads for PowerWorks® mount into an integral track in the horizontal rail. Allows shelf to slide along track. Requires 18" tile for mounting (i.e. must be a half or fully segmented panel) 	24 x 16-1/2 x 14-1/2"	PRDV24/WW/OM18	<input type="checkbox"/>	<input type="checkbox"/>	<input type="checkbox"/>	<input type="checkbox"/>	34.0#	
	30 x 16-1/2 x 14-1/2"	PRDV30/WW/OM18	<input type="checkbox"/>	<input type="checkbox"/>	<input type="checkbox"/>	<input type="checkbox"/>	36.0#	
	36 x 16-1/2 x 14-1/2"	PRDV36/WW/OM18	<input type="checkbox"/>	<input type="checkbox"/>	<input type="checkbox"/>	<input type="checkbox"/>	44.0#	
	42 x 16-1/2 x 14-1/2"	PRDV42/WW/OM18	<input type="checkbox"/>	<input type="checkbox"/>	<input type="checkbox"/>	<input type="checkbox"/>	49.0#	
	48 x 16-1/2 x 14-1/2"	PRDV48/WW/OM18	<input type="checkbox"/>	<input type="checkbox"/>	<input type="checkbox"/>	<input type="checkbox"/>	54.0#	
	54 x 16-1/2 x 14-1/2"	PRDV54/WW/OM18	<input type="checkbox"/>	<input type="checkbox"/>	<input type="checkbox"/>	<input type="checkbox"/>	60.0#	
	60 x 16-1/2 x 14-1/2"	PRDV60/WW/OM18	<input type="checkbox"/>	<input type="checkbox"/>	<input type="checkbox"/>	<input type="checkbox"/>	64.0#	

A **B** **C** **D** **E**

HOW TO ORDER

Indicate the following information on order form:

- Quantity of each item.
- Model number, including options. See "How To Build a Model Number".
- Any special service required.

Note: • The indicates that a choice is required.
 • The absence of the indicates that no choice is required.
 • Alpha-numeric characters in place of indicate that no other alternatives are available.

HOW TO BUILD A MODEL NUMBER

- A** Select basic model.
- B** Select assembly.

F	- Fully Assembled
U	- Unassembled
- C** Select paint color.
Refer to the **Product Color Options** page in this catalog.
- D** Select veneer color.
Refer to the **Product Color Options** page in this catalog.
- E** Select key alike.

KA	- Key alike
KS	- Key standard
NLC	- No lock core

Universal Storage and Accessories

Overhead Storage

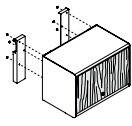
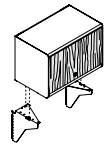
	MODEL	W x H x D	MODEL NUMBER					Approx. Packaged Weight
			Basic Model	Assembly	Paint Color	Veneer Color	Key Option	
 PRDV	Veneer Door Overhead Cabinet-Load Bar Mount (LB) <ul style="list-style-type: none"> Load Bar mount overheads (LB) for PowerWorks® hang from an externally mounted load bar Load Bar purchased separately 	24 x 16-1/2 x 14-1/2"	PRDV24/WW/LB	<input type="checkbox"/>	<input type="checkbox"/>	<input type="checkbox"/>	<input type="checkbox"/>	34.0#
		30 x 16-1/2 x 14-1/2"	PRDV30/WW/LB	<input type="checkbox"/>	<input type="checkbox"/>	<input type="checkbox"/>	<input type="checkbox"/>	36.0#
		36 x 16-1/2 x 14-1/2"	PRDV36/WW/LB	<input type="checkbox"/>	<input type="checkbox"/>	<input type="checkbox"/>	<input type="checkbox"/>	44.0#
		42 x 16-1/2 x 14-1/2"	PRDV42/WW/LB	<input type="checkbox"/>	<input type="checkbox"/>	<input type="checkbox"/>	<input type="checkbox"/>	49.0#
		48 x 16-1/2 x 14-1/2"	PRDV48/WW/LB	<input type="checkbox"/>	<input type="checkbox"/>	<input type="checkbox"/>	<input type="checkbox"/>	54.0#
		54 x 16-1/2 x 14-1/2"	PRDV54/WW/LB	<input type="checkbox"/>	<input type="checkbox"/>	<input type="checkbox"/>	<input type="checkbox"/>	60.0#
		60 x 16-1/2 x 14-1/2"	PRDV60/WW/LB	<input type="checkbox"/>	<input type="checkbox"/>	<input type="checkbox"/>	<input type="checkbox"/>	64.0#
 PRDV	Veneer Door Overhead Cabinet-Upmount <ul style="list-style-type: none"> Upmount brackets position the storage component on a 54" high panel to the same height as on 66" high panels On a 54" high panel, clearance between the cabinet and worksurface is 20" On a 48" high panel, clearance between the cabinet and worksurface is 14" 	24 x 16-1/2 x 14-1/2"	PRDV24/WW/UM	<input type="checkbox"/>	<input type="checkbox"/>	<input type="checkbox"/>	<input type="checkbox"/>	34.0#
		30 x 16-1/2 x 14-1/2"	PRDV30/WW/UM	<input type="checkbox"/>	<input type="checkbox"/>	<input type="checkbox"/>	<input type="checkbox"/>	36.0#
		36 x 16 1/2 x 14 1/2"	PRDV36/WW/UM	<input type="checkbox"/>	<input type="checkbox"/>	<input type="checkbox"/>	<input type="checkbox"/>	44.0#
		42 x 16 1/2 x 14 1/2"	PRDV42/WW/UM	<input type="checkbox"/>	<input type="checkbox"/>	<input type="checkbox"/>	<input type="checkbox"/>	49.0#
		48 x 16 1/2 x 14 1/2"	PRDV48/WW/UM	<input type="checkbox"/>	<input type="checkbox"/>	<input type="checkbox"/>	<input type="checkbox"/>	54.0#
		54 x 16 1/2 x 14 1/2"	PRDV54/WW/UM	<input type="checkbox"/>	<input type="checkbox"/>	<input type="checkbox"/>	<input type="checkbox"/>	60.0#
		60 x 16 1/2 x 14 1/2"	PRDV60/WW/UM	<input type="checkbox"/>	<input type="checkbox"/>	<input type="checkbox"/>	<input type="checkbox"/>	64.0#
			A	B	C	D	E	

HOW TO ORDER

Indicate the following information on order form:

- Quantity of each item.
- Model number, including options. See "How To Build a Model Number".
- Any special service required.

Note: • The indicates that a choice is required.

- The absence of the indicates that no choice is required.
- Alpha-numeric characters in place of indicate that no other alternatives are available.

HOW TO BUILD A MODEL NUMBER

A Select basic model.

B Select assembly.

F	- Fully Assembled
U	- Unassembled

C Select paint color.

Refer to the **Product Color Options** page in this catalog.

D Select veneer color.

Refer to the **Product Color Options** page in this catalog.

E Select key alike.

KA	- Key alike
KS	- Key standard
NLC	- No lock core

Universal Storage and Accessories

Overhead Storage

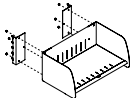
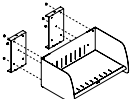
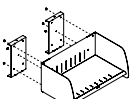
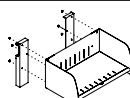
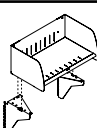
	MODEL	W x H x D	MODEL NUMBER		Approx. Packaged Weight
			Basic Model	Paint Color	
 <p>ULSR</p>	Low Shelf-On-Module • On-Module shelves (PM) mount into slots in vertical posts. Shelves must be same width as panel mounted to. Does not require a 12" tile for mounting. Allows for vertical adjustment in 1" increments	24 x 10-1/2 x 13-1/4"	ULSR24/WW/PM	<input type="checkbox"/>	14.0#
		30 x 10-1/2 x 13-1/4"	ULSR30/WW/PM	<input type="checkbox"/>	16.0#
		36 x 10-1/2 x 13-1/4"	ULSR36/WW/PM	<input type="checkbox"/>	17.0#
		42 x 10-1/2 x 13-1/4"	ULSR42/WW/PM	<input type="checkbox"/>	19.0#
		48 x 10-1/2 x 13-1/4"	ULSR48/WW/PM	<input type="checkbox"/>	20.0#
		54 x 10-1/2 x 13-1/4"	ULSR54/WW/PM	<input type="checkbox"/>	22.0#
		60 x 10-1/2 x 13-1/4"	ULSR60/WW/PM	<input type="checkbox"/>	24.0#
 <p>ULSR</p>	Low Shelf-Off-Module • Off-Module shelves (OM12) mount into the integral track in the horizontal rail. Allows shelf to slide along track. Requires a 12" tile for mounting (i.e. must be a half or fully segmented panel)	24 x 10-1/2 x 13-1/4"	ULSR24/WW/OM12	<input type="checkbox"/>	14.0#
		30 x 10-1/2 x 13-1/4"	ULSR30/WW/OM12	<input type="checkbox"/>	16.0#
		36 x 10-1/2 x 13-1/4"	ULSR36/WW/OM12	<input type="checkbox"/>	17.0#
		42 x 10-1/2 x 13-1/4"	ULSR42/WW/OM12	<input type="checkbox"/>	19.0#
		48 x 10-1/2 x 13-1/4"	ULSR48/WW/OM12	<input type="checkbox"/>	20.0#
		54 x 10-1/2 x 13-1/4"	ULSR54/WW/OM12	<input type="checkbox"/>	22.0#
		60 x 10-1/2 x 13-1/4"	ULSR60/WW/OM12	<input type="checkbox"/>	24.0#
 <p>ULSR</p>	Low Shelf-Off-Module • Off-Module shelves (OM18) mount into the integral track in the horizontal rail. Allows shelf to slide along track. Requires a 18" tile for mounting (i.e. must be a half or fully segmented panel)	24 x 10-1/2 x 13-1/4"	ULSR24/WW/OM18	<input type="checkbox"/>	14.0#
		30 x 10-1/2 x 13-1/4"	ULSR30/WW/OM18	<input type="checkbox"/>	16.0#
		36 x 10-1/2 x 13-1/4"	ULSR36/WW/OM18	<input type="checkbox"/>	17.0#
		42 x 10-1/2 x 13-1/4"	ULSR42/WW/OM18	<input type="checkbox"/>	19.0#
		48 x 10-1/2 x 13-1/4"	ULSR48/WW/OM18	<input type="checkbox"/>	20.0#
		54 x 10-1/2 x 13-1/4"	ULSR54/WW/OM18	<input type="checkbox"/>	22.0#
		60 x 10-1/2 x 13-1/4"	ULSR60/WW/OM18	<input type="checkbox"/>	24.0#
 <p>ULSR</p>	Low Shelf-Load Bar Mount • Load Bar mount overheads (LB) for PowerWorks® hang from an externally mounted load bar • Load Bar purchased separately	24 x 10-1/2 x 13-1/4"	ULSR24/WW/LB	<input type="checkbox"/>	14.0#
		30 x 10-1/2 x 13-1/4"	ULSR30/WW/LB	<input type="checkbox"/>	16.0#
		36 x 10-1/2 x 13-1/4"	ULSR36/WW/LB	<input type="checkbox"/>	17.0#
		42 x 10-1/2 x 13-1/4"	ULSR42/WW/LB	<input type="checkbox"/>	19.0#
		48 x 10-1/2 x 13-1/4"	ULSR48/WW/LB	<input type="checkbox"/>	20.0#
		54 x 10-1/2 x 13-1/4"	ULSR54/WW/LB	<input type="checkbox"/>	22.0#
		60 x 10-1/2 x 13-1/4"	ULSR60/WW/LB	<input type="checkbox"/>	24.0#
 <p>ULSR</p>	Low Shelf-Upmount • Upmount brackets position the storage component on a 54" high panel to the same height as on 66" high panels • On a 54" high panel, clearance between the cabinet and worksurface is 20" • On a 48" high panel, clearance between the cabinet and worksurface is 14"	24 x 10-1/2 x 13-1/4"	ULSR24/WW/UM	<input type="checkbox"/>	14.0#
		30 x 10-1/2 x 13-1/4"	ULSR30/WW/UM	<input type="checkbox"/>	16.0#
		36 x 10-1/2 x 13-1/4"	ULSR36/WW/UM	<input type="checkbox"/>	17.0#
		42 x 10-1/2 x 13-1/4"	ULSR42/WW/UM	<input type="checkbox"/>	19.0#
		48 x 10-1/2 x 13-1/4"	ULSR48/WW/UM	<input type="checkbox"/>	20.0#
		54 x 10-1/2 x 13-1/4"	ULSR54/WW/UM	<input type="checkbox"/>	22.0#
		60 x 10-1/2 x 13-1/4"	ULSR60/WW/UM	<input type="checkbox"/>	24.0#

A

B

HOW TO ORDER

Indicate the following information on order form:

- Quantity of each item.
- Model number, including options. See "How To Build a Model Number".
- Any special service required.

Note: • The indicates that a choice is required.
 • The absence of the indicates that no choice is required.
 • Alpha-numeric characters in place of indicate that no other alternatives are available.

HOW TO BUILD A MODEL NUMBER

- A** Select basic model.
- B** Select paint color.
 Refer to the **Product Color Options** page in this catalog.

Universal Storage and Accessories

Overhead Storage

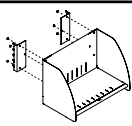
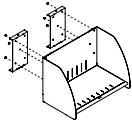
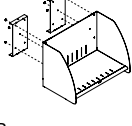
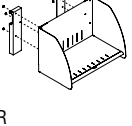
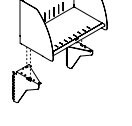
	MODEL	W x H x D	MODEL NUMBER		Approx. Packaged Weight
			Basic Model	Paint Color	
 URSR	Regular Shelf-On-Module • On-Module shelves mount into slots in vertical posts. Shelves must be same width as panel mounted to. Does not require a 12" tile for mounting. Allows for vertical adjustment in 1" increments	24 x 16-1/2 x 13-1/4"	URSR24/WW/PM	<input type="checkbox"/>	19.0#
		30 x 16-1/2 x 13-1/4"	URSR30/WW/PM	<input type="checkbox"/>	20.0#
		36 x 16-1/2 x 13-1/4"	URSR36/WW/PM	<input type="checkbox"/>	22.0#
		42 x 16-1/2 x 13-1/4"	URSR42/WW/PM	<input type="checkbox"/>	23.0#
		48 x 16-1/2 x 13-1/4"	URSR48/WW/PM	<input type="checkbox"/>	25.0#
		54 x 16-1/2 x 13-1/4"	URSR54/WW/PM	<input type="checkbox"/>	27.0#
		60 x 16-1/2 x 13-1/4"	URSR60/WW/PM	<input type="checkbox"/>	28.0#
 URSR	Regular Shelf-Off-Module • Off-Module shelves (OM12) mount into the integral track in the horizontal rail. Allows shelf to slide along track. Requires a 12" tile for mounting (i.e. must be a half or fully segmented panel)	24 x 16-1/2 x 13-1/4"	URSR24/WW/OM12	<input type="checkbox"/>	19.0#
		30 x 16-1/2 x 13-1/4"	URSR30/WW/OM12	<input type="checkbox"/>	20.0#
		36 x 16-1/2 x 13-1/4"	URSR36/WW/OM12	<input type="checkbox"/>	22.0#
		42 x 16-1/2 x 13-1/4"	URSR42/WW/OM12	<input type="checkbox"/>	23.0#
		48 x 16-1/2 x 13-1/4"	URSR48/WW/OM12	<input type="checkbox"/>	25.0#
		54 x 16-1/2 x 13-1/4"	URSR54/WW/OM12	<input type="checkbox"/>	27.0#
		60 x 16-1/2 x 13-1/4"	URSR60/WW/OM12	<input type="checkbox"/>	28.0#
 URSR	Regular Shelf-Off-Module • Off-Module shelves (OM18) mount into the integral track in the horizontal rail. Allows shelf to slide along track. Requires a 18" tile for mounting (i.e. must be a half or fully segmented panel)	24 x 16-1/2 x 13-1/4"	URSR24/WW/OM18	<input type="checkbox"/>	19.0#
		30 x 16-1/2 x 13-1/4"	URSR30/WW/OM18	<input type="checkbox"/>	20.0#
		36 x 16-1/2 x 13-1/4"	URSR36/WW/OM18	<input type="checkbox"/>	22.0#
		42 x 16-1/2 x 13-1/4"	URSR42/WW/OM18	<input type="checkbox"/>	23.0#
		48 x 16-1/2 x 13-1/4"	URSR48/WW/OM18	<input type="checkbox"/>	25.0#
		54 x 16-1/2 x 13-1/4"	URSR54/WW/OM18	<input type="checkbox"/>	27.0#
		60 x 16-1/2 x 13-1/4"	URSR60/WW/OM18	<input type="checkbox"/>	28.0#
 URSR	Regular Shelf-Load Bar Mount • Load Bar mount overheads (LB) for PowerWorks® hang from an externally mounted load bar • Load Bar purchased separately	24 x 16-1/2 x 13-1/4"	URSR24/WW/LB	<input type="checkbox"/>	19.0#
		30 x 16-1/2 x 13-1/4"	URSR30/WW/LB	<input type="checkbox"/>	20.0#
		36 x 16-1/2 x 13-1/4"	URSR36/WW/LB	<input type="checkbox"/>	22.0#
		42 x 16-1/2 x 13-1/4"	URSR42/WW/LB	<input type="checkbox"/>	23.0#
		48 x 16-1/2 x 13-1/4"	URSR48/WW/LB	<input type="checkbox"/>	25.0#
		54 x 16-1/2 x 13-1/4"	URSR54/WW/LB	<input type="checkbox"/>	27.0#
		60 x 16-1/2 x 13-1/4"	URSR60/WW/LB	<input type="checkbox"/>	28.0#
 URSR	Regular Shelf-Upmount • Upmount brackets position the storage component on a 54" high panel to the same height as on 66" high panels • On a 54" high panel, clearance between the cabinet and worksurface is 20" • On a 48" high panel, clearance between the cabinet and worksurface is 14"	24 x 16-1/2 x 13-1/4"	URSR24/WW/UM	<input type="checkbox"/>	19.0#
		30 x 16-1/2 x 13-1/4"	URSR30/WW/UM	<input type="checkbox"/>	20.0#
		36 x 16-1/2 x 13-1/4"	URSR36/WW/UM	<input type="checkbox"/>	22.0#
		42 x 16-1/2 x 13-1/4"	URSR42/WW/UM	<input type="checkbox"/>	23.0#
		48 x 16-1/2 x 13-1/4"	URSR48/WW/UM	<input type="checkbox"/>	25.0#
		54 x 16-1/2 x 13-1/4"	URSR54/WW/UM	<input type="checkbox"/>	27.0#
		60 x 16-1/2 x 13-1/4"	URSR60/WW/UM	<input type="checkbox"/>	28.0#

A

B

HOW TO ORDER

Indicate the following information on order form:

- Quantity of each item.
- Model number, including options. See "How To Build a Model Number".
- Any special service required.

Note: • The indicates that a choice is required.

- The absence of the indicates that no choice is required.
- Alpha-numeric characters in place of indicate that no other alternatives are available.

HOW TO BUILD A MODEL NUMBER

A Select basic model.

B Select paint color.
Refer to the **Product Color Options** page in this catalog.

Universal Storage and Accessories

Overhead Accessories

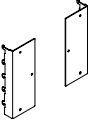
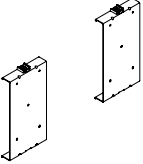
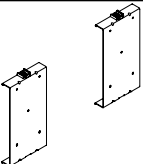
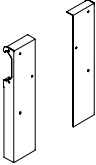
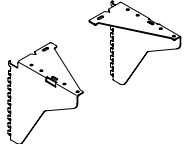
MODEL	MODEL NUMBER		Approx. Packaged Weight
	Basic Model	Trim Color	
 <p>HRDPT</p> <p>Universal Overhead On-Module Mounting Bracket</p> <ul style="list-style-type: none"> Sold in pairs / Black only Mounts into slots in vertical posts Allows for vertical adjustments in 1" increments Only necessary to order if changing mounting style 	46.0233.SET		1.0#
 <p>HRDPT</p> <p>Universal Overhead Off-Module Mounting Bracket-12" Tiles</p> <ul style="list-style-type: none"> Sold in pairs / Black only Mounts into integral track in horizontal rail, attaches to 12" high tiles Allows cabinet or shelf to slide along track Only necessary to order if changing mounting style 	46.0234.SET		1.0#
 <p>HRDPT</p> <p>Universal Overhead Off-Module Mounting Bracket-18" Tiles</p> <ul style="list-style-type: none"> Sold in pairs / Black only Mounts into integral track in horizontal rail, attaches to 18" high tiles Allows cabinet or shelf to slide along track Only necessary to order if changing mounting style 	46.1229.SET		1.0#
 <p>HRDPT</p> <p>Load Bar Brackets</p> <ul style="list-style-type: none"> Load Bar mount overhangs hang from an externally mounted load bar Load Bar purchased separately, Sold in pairs 	46.2103	<input type="checkbox"/>	1.0#
 <p>HRDPT</p> <p>Upmount Brackets</p> <ul style="list-style-type: none"> Upmount brackets position the storage component on a 54" high panel to the same height as on 66" high panels Sold in pairs 	46.1234	<input type="checkbox"/>	1.0#

A

B

HOW TO ORDER

Indicate the following information on order form:

- Quantity of each item.
- Model number, including options. See "How To Build a Model Number".
- Any special service required.

Note:



- The indicates that a choice is required.
- The absence of the indicates that no choice is required.
- Alpha-numeric characters in place of indicate that no other alternatives are available.

HOW TO BUILD A MODEL NUMBER

- A** Select basic model.
- B** Select trim color.
Refer to the **Product Color Options** page in this catalog.

Universal Storage and Accessories

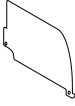
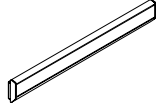
Overhead Accessories

	MODEL	W x H	MODEL NUMBER				Approx. Packaged Weight
			Basic Model	Trim Color	Mounting	Fabric Color	
	Universal Shelf Dividers • Steel shelf dividers with powder-coated finish • Fits on all shelves and cabinets	7-1/4 x 11-1/2"	NSD	<input type="checkbox"/>			1.0#
HRDPT							
	Wall Mounted Load Bar • Supports overhead storage on drywall or other non-panel applications	24"	SWLB.24	<input type="checkbox"/>			5.0#
		30"	SWLB.30	<input type="checkbox"/>			6.0#
		36"	SWLB.36	<input type="checkbox"/>			7.0#
		42"	SWLB.42	<input type="checkbox"/>			8.0#
		48"	SWLB.48	<input type="checkbox"/>			10.0#
		54"	SWLB.54	<input type="checkbox"/>			13.0#
		60"	SWLB.60	<input type="checkbox"/>			12.0#
		66"	SWLB.66	<input type="checkbox"/>			13.0#
		72"	SWLB.72	<input type="checkbox"/>			14.0#
		84"	SWLB.84	<input type="checkbox"/>			17.0#
		96"	SWLB.96	<input type="checkbox"/>			19.0#
HRDPT							
	Overhead Tackboard • Hangs from bottom of flipper door cabinet or shelf • When hanging from Venus® overhead, specify attachment bar BMB (purchase separately) • Includes mounting brackets in black only • Specify 20" high tackboard to cover vertical space between bottom of overhead and top of worksurface, when worksurface is positioned at 29" above finished floor	24 x 12"	PTB02412	<input type="checkbox"/>	<input type="checkbox"/>	<input type="checkbox"/>	3.0#
		30 x 12"	PTB03012	<input type="checkbox"/>	<input type="checkbox"/>	<input type="checkbox"/>	3.0#
		36 x 12"	PTB03612	<input type="checkbox"/>	<input type="checkbox"/>	<input type="checkbox"/>	3.0#
		42 x 12"	PTB04212	<input type="checkbox"/>	<input type="checkbox"/>	<input type="checkbox"/>	4.0#
		48 x 12"	PTB04812	<input type="checkbox"/>	<input type="checkbox"/>	<input type="checkbox"/>	4.0#
		54 x 12"	PTB05412	<input type="checkbox"/>	<input type="checkbox"/>	<input type="checkbox"/>	4.0#
		60 x 12"	PTB06012	<input type="checkbox"/>	<input type="checkbox"/>	<input type="checkbox"/>	4.0#
		24 x 20"	PTB02420	<input type="checkbox"/>	<input type="checkbox"/>	<input type="checkbox"/>	4.0#
		30 x 20"	PTB03020	<input type="checkbox"/>	<input type="checkbox"/>	<input type="checkbox"/>	5.0#
		36 x 20"	PTB03620	<input type="checkbox"/>	<input type="checkbox"/>	<input type="checkbox"/>	6.0#
		42 x 20"	PTB04220	<input type="checkbox"/>	<input type="checkbox"/>	<input type="checkbox"/>	7.0#
		48 x 20"	PTB04820	<input type="checkbox"/>	<input type="checkbox"/>	<input type="checkbox"/>	8.0#
		54 x 20"	PTB05420	<input type="checkbox"/>	<input type="checkbox"/>	<input type="checkbox"/>	9.0#
60 x 20"	PTB06020	<input type="checkbox"/>	<input type="checkbox"/>	<input type="checkbox"/>	10.0#		
P1TB0 - KD1 PTB0 - Pass Through							

A

B

C

D

HOW TO ORDER

Indicate the following information on order form:

- Quantity of each item.
- Model number, including options. See "How To Build a Model Number".
- Any special service required.

Note: • The indicates that a choice is required.

- The absence of the indicates that no choice is required.
- Alpha-numeric characters in place of indicate that no other alternatives are available.

HOW TO BUILD A MODEL NUMBER

A Select basic model.

B Select trim color.
Refer to the **Product Color Options** page in this catalog.

C Select load bar mounting.

YLBM - Load bar mounted
NLBM - Not load bar mounted

D Select fabric color.

Universal Storage and Accessories

Universal Overhead Task Light

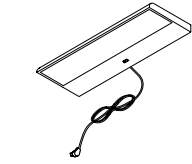

HRDPT

MODEL

- Universal Overhead Task Light**
- Attaches to the bottom of overhead storage cabinet
 - Task lights are specified by the cabinet width to which they are attached. See "INFORMATION" at bottom of PO Catalog page for sizing chart.
 - Attachment hardware included
 - Electronic NPF ballast
 - T5 Florescent bulb
 - Center located, 9' cord with 90 degree, 3 prong plug
 - Center located, two position rocker switch
 - Cord and power switch on 24" wide located left of center
 - Standard color of casing is black

W

MODEL NUMBER

Basic Model

18"	TLT5.18
24"	TLT5.24
36"	TLT5.36
48"	TLT5.48

Approx. Packaged Weight

3.4#
3.9#
5.3#
6.7#



HOW TO ORDER

Indicate the following information on order form:

1. Quantity of each item.
2. Model number, including options. See "How To Build a Model Number".
3. Any special service required.

Note: • The indicates that a choice is required.

- The absence of the indicates that no choice is required.
- Alpha-numeric characters in place of indicate that no other alternatives are available.

HOW TO BUILD A MODEL NUMBER

A Select basic model.

INFORMATION

TASK LIGHT CABINET WIDTH

Cabinet Width	Light Width
24"	18"
30"	24"
36"	24"
42"	36"
48"	36"
54"	48"
60"	48"

Universal & Venus Accessories

LED Task Lights

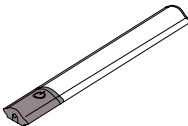
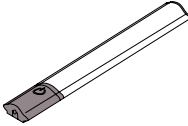
	MODEL	W	MODEL NUMBER		Approx. Packaged Weight
			Basic Model		
 <p>HRDPT</p>	Single Unit - Overhead LED Task Light	12"	LEDTK.12.SGL.GN		1.2#
	<ul style="list-style-type: none"> Attaches to the bottom of overhead storage cabinets or shelving Task lights are specified by the cabinet width to which they are attached. See "INFORMATION" at bottom of price list page for sizing chart. Slim profile mounts effortlessly via magnets or screw-in bracket Attachment hardware included Touch and hold dimmability with last-state memory Silver anodized aluminum body/black plastic end caps 18W energy consumption 9' power supply Includes 2 cord managers 	17"	LEDTK.17.SGL.GN		1.6#
		31"	LEDTK.31.SGL.GN		2.1#
		44"	LEDTK.44.SGL.GN		2.3#
 <p>HRDPT</p>	Starter Unit - Overhead LED Task Light	12"	LEDTK.12.DCP.GN		1.2#
	<ul style="list-style-type: none"> Attaches to the bottom of overhead storage cabinets or shelving Task lights are specified by the cabinet width to which they are attached. See "INFORMATION" below for sizing chart. Slim profile mounts effortlessly via magnets or screw-in bracket Attachment hardware included Touch and hold dimmability with last-state memory Silver anodized aluminum body/black plastic end caps Daisy chain with Adder units 60W energy consumption 11' power supply Includes 2 cord managers Refer to Interlinking Combination table below for optimal performance of daisy chained fixtures 	17"	LEDTK.17.DCP.GN		1.6#
		31"	LEDTK.31.DCP.GN		2.1#
		44"	LEDTK.44.DCP.GN		2.3#

A

HOW TO ORDER

Indicate the following information on order form:

- Quantity of each item.
- Model number, including options. See "How To Build a Model Number".
- Any special service required.

Note: • The indicates that a choice is required.

- The absence of the indicates that no choice is required.
- Alpha-numeric characters in place of indicate that no other alternatives are available.

HOW TO BUILD A MODEL NUMBER

- A** Select basic model.

INFORMATION

LED TASK LIGHT CABINET WIDTH

Cabinet Width	Light Width
24"	12" or 17"
30"	17"
36"	17"
42"	31"
48"	31"
54"	44"
60"	44"
66"	44"
72"	44"

Universal & Venus Accessories

LED Task Light

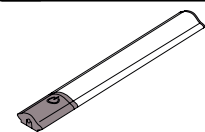

HRDPT

MODEL

W

MODEL NUMBER

Basic Model

Approx. Packaged Weight

- Adder Unit - Overhead LED Task Light**
- Attaches to the bottom of overhead storage cabinets or shelving
 - Task lights are specified by the cabinet width to which they are attached. See "INFORMATION" below for sizing chart.
 - Slim profile mounts effortlessly via magnets or screw-in bracket
 - Attachment hardware included
 - Touch and hold dimmability with last-state memory
 - Silver anodized aluminum body/black plastic end caps
 - Daisy chain with Starter units
 - 18' jumper cord and connect to starter unit
 - Includes 2 cord managers
 - Does not include power supply; must purchase starter unit with power supply
 - Controlled by the on/off/dimmer of the starter unit
 - Refer to Interlinking Combination table below for optimal performance of daisy chained fixtures

12"	LEDTK.12.DCA.GN
17"	LEDTK.17.DCA.GN
31"	LEDTK.31.DCA.GN
44"	LEDTK.44.DCA.GN

1.2#
1.6#
2.1#
2.3#

A

HOW TO ORDER

Indicate the following information on order form:

1. Quantity of each item.
2. Model number, including options. See "How To Build a Model Number".
3. Any special service required.

Note: • The indicates that a choice is required.

- The absence of the indicates that no choice is required.
- Alpha-numeric characters in place of indicate that no other alternatives are available.

HOW TO BUILD A MODEL NUMBER

A Select basic model.

INTERLOCKING SPECIFICATIONS

INTERLINKING COMBINATIONS (DAISY CHAIN)

# of 12"	# of 17"	# of 31"	# of 44"
6	0	0	0
5	1	0	0
5	0	0	0
4	2	0	0
4	1	0	0
4	0	1	0
4	0	0	0
3	2	0	0
3	1	1	0
3	1	0	0
3	0	1	0
3	0	0	1
3	0	0	0
2	3	0	0
2	2	1	0
2	1	1	0
2	0	2	0
2	0	0	1





INTERLOCKING SPECIFICATIONS

INTERLINKING COMBINATIONS (cont.) (DAISY CHAIN)

# of 12"	# of 17"	# of 31"	# of 44"
1	4	0	0
1	3	0	0
1	2	1	0
1	2	0	1
1	1	1	0
1	1	0	1
0	4	0	0
0	3	1	0
0	3	0	0
0	2	1	0
0	2	0	1
0	1	2	0
0	1	1	1
0	1	0	1
0	0	3	0
0	0	2	0
0	0	1	1
0	0	0	2

Universal & Venus Accessories

REED LED Task Lights

		MODEL NUMBER	
D x L x H		Basic Model	
 <p>LED Task Light with Power Supply</p> <ul style="list-style-type: none"> For use with any overhead or shelf Screw mount for wood applications or magnet mount for metal application Silver aluminum finish, white end caps and black power cord Single touch on/off and touch-and-hold 100%-15% continuous dimming pad with last state memory Automatic turn off after 10 hours LED rated lifespan for 50,000 hours Cord length 9' on 15W power supply, 12' on 60W supply Refer to charts below for specifications 	Stand Alone Model CANNOT be Interconnected		
	15W Power Supply Stand Along Light		
	17" LED Standard Output - 9 Watts	2" x 16.4" x .5"	33.REED.17.X
	60W Power Supply Starter Units		
	17" LED Standard Output - 9 Watts	2" x 16.4" x .5"	33.REED.STARTER.X
31" LED Standard Output - 18 Watts	2" x 30.1" x .5"	33.REED.31.X	
44" LED Standard Output - 25 Watts	2" x 43.7" x .5"	33.REED.44.X	
58" LED Standard Output - 33.6 Watts	2" x 57.4" x .5"	33.REED.58.X	
 <p>LED Adder Light without Power Supply</p> <ul style="list-style-type: none"> For use with any overhead or shelf Screw mount for wood applications or magnet mount for metal application Silver aluminum finish, white end caps and black power cord Single touch on/off and touch-and-hold 100%-15% continuous dimming pad with last state memory Automatic turn off after 10 hours LED rated lifespan for 50,000 hours Adder units include an 8" & 30" interconnect cord (54" cord must be ordered separate) Refer to charts below for specifications 	Adder Lights Require Starter Unit to Function		
	17" Adder W/Interconnect Kit, Mounting Kit	2" x 16.4" x .5"	33.ADDER.17.X
	31" Adder W/Interconnect Kit, Mounting Kit	2" x 30.1" x .5"	33.ADDER.31.X
	44" Adder W/Interconnect Kit, Mounting Kit	2" x 43.7" x .5"	33.ADDER.44.X
	58" Adder W/Interconnect Kit, Mounting Kit	2" x 57.4" x .5"	33.ADDER.58.X
 <p>Interconnect Cord</p> <ul style="list-style-type: none"> 60 watt power supply required when interconnecting lights Total interconnected system wattage cannot meet or exceed 60W - see chart 	8"	33.REED.JUMP8.X	
	30"	33.REED.JUMP30.X	
	54"	33.REED.JUMP54.X	
 <p>Occupancy Sensor with End-to-End Connector</p> <ul style="list-style-type: none"> Optional occupancy sensor shuts fixture off after 30 minutes of inactivity One occupancy sensor needed per string of interconnected lights 	2" x 2.3" x .5"	33.REED.OS.CON.X	
	Horizontal Magnetic Cord Manager		32.LEDMAG.X
		Set of 2	

A

HOW TO ORDER

Indicate the following information on order form:

- Quantity of each item.
- Model number, including options. See "How To Build a Model Number".
- Any special service required.

Note: • The indicates that a choice is required.

- The absence of the indicates that no choice is required.
- Alpha-numeric characters in place of indicate that no other alternatives are available.

HOW TO BUILD A MODEL NUMBER

A Select basic model.

Overall Length	Suggested Shelf Size	LED's Per Light	Wattage Per Light
17"	24" - 36"	24	6.6
31"	42" x 48"	48	14.8
44"	56" x 60"	72	21.8
58"	> 72"	96	28.2

INTERCONNECTED LIGHT COMBINATIONS			
17" Lights	31" Lights	44" Lights	58" Lights
6	0	0	0
5	0	0	0
4	1	0	0
4	0	0	0
3	1	0	0
3	0	1	0
3	0	0	0
2	2	0	0
2	1	0	0
2	0	1	0
2	0	0	1
2	0	0	0
1	2	0	0
1	1	1	0
1	0	1	0
1	0	0	1
0	2	0	0
0	1	1	0
0	0	2	0

For example, 3-17" lights can be interconnected with 1-44" light to work off of a 60W power supply.

Venus® Storage and Accessories

General Information

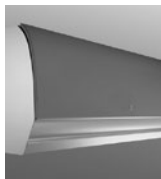

Solid Overhead (BLCS)

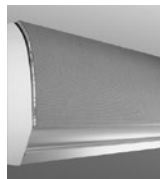

Fabric Overhead (BLCF)



Laminate Overhead (BLCL)

Features

Cabinet available in 24 colors	•	•	•
Painted lower door available in 24 colors	•	•	•
Translucent upper door	•		
Fabric upper door		•	
Laminate upper door			•
Fully assembled	•	•	•
Task light	•	•	•
Hanging tackboard	•	•	•
Hanging tool rail	•	•	•

SPECIFICATIONS

Cabinet Construction

The overhead cabinet shall be assembled complete and powder-coated in widths of 30", 36", 42", 48", 54" and 60". The overall dimensions of the end panels shall be 17" high and 16-1/2" deep. The shelf depth shall be 13-1/2". Inside height shall allow for oversize binders, such as Folscap and A4, to be stored vertically. The cabinet top, bottom, and shelf shall be fabricated from 18-gauge steel. Side panels shall be fabricated from 14-gauge steel and attached via resistance welding. Cabinet top, bottom, and shelf shall contain reinforcements fabricated from 18-gauge steel and attached via resistance welding. Pins for door and shroud attachment shall be fabricated from 3/8" diameter steel and attached via resistance welding. Shroud will be black only. All accessible or visible edges shall be smooth and rounded.

Door Construction

The upper door shall be available in colored or translucent extruded rigid polypropylene with spattercoat finish, fabric or laminate applied. The overall door thickness shall be

3/8" with a .075 wall thickness. The door shall be capped with polycarbonate endcaps and attached to the case with polycarbonate arms. A center lock mechanism will be utilized between the upper and lower doors for security. The lower door shall be an aluminum extrusion with a powder-coat finish. The lower door shall have a .075 thickness and be ergonomic in design. The door shall be capped and attached to the case with polycarbonate arms.

Door Operation

The overhead cabinet doors shall be effortlessly operated from either a seated or standing position through use of the upper door or lower door. The upper door and lower door shall be synchronized in motion through the use of two 10-gauge linkages. The doors shall be assisted with two extension springs and require less than 5 pounds of force to operate. Either door shall be opened or closed with a closed fist. The upper door shall open over the outside of case.

Cabinet Installation

The overhead cabinet shall include separate

mounting brackets that allow for assembly to panels or desk systems. The brackets shall be attached to the back of the overhead via a hook and groove system and two screw fasteners. The hook and groove system shall allow the installer to assemble brackets to a panel before attaching to overhead. The desk supports shall attach to the bottom of overhead via four screw fasteners.

Task Lights

Task lights shall be available which suspend from the underside of the cabinet. The task light shall mount flush with the underside of the overhead cabinet via two cantilever brackets. Task light shall be offered fully assembled in black only. The task light shall have an 8' long cord with three-prong grounded plug, and be available in three versions: standard high-power factor ballast, variable (high/low) high-power factor ballast, and electronic ballast. All three options shall include a cool white lamp. Chords shall be routed into and through wire trough located at rear underside of cabinet shelf. Installation and removal shall be accomplished without the use of tools or fasteners.

Shelf Dividers

Shelf dividers shall be powder-coated, 18-gauge steel and offered in the same color as the overhead case. Installation and removal shall be accomplished without the use of tools or fasteners.

Tackboard/Tool Rail Mounting Bar

A powder-coated, 14-gauge bracket shall be available for the attachment of a hanging tool rail or tackboard to the underside of the overhead. The bracket shall be specified in the same widths as the overhead and is offered in the same colors as the overhead case.

Overhead Hanging Tackboard

Tackboards shall be available in 12" height and in 24", 30", 36", 42", 48", 54", and 60" widths. The tackboard shall be constructed of 3/4" industrial insulation board covered with fabric. The mounting brackets shall be steel powder-coated and attached to the coreboard with T-nuts and machine screws. Fabric shall be attached to the coreboard with staples. A mounting bracket bar is required to attach the tackboard to the overhead cabinet.

Venus® Storage and Accessories

Overhead Storage

MODEL	W x H x D	MODEL NUMBER				Approx. Packaged Weight	
		Basic Model	Cabinet Paint Color	Upper Door Solid Color	Key Option		
<p>VNOKD - KD1/KD2 VNO - Pass Through</p>	Venus® Overhead Cabinet-Solid Color Upper Door-On Module (PM)	24 x 17 x 19-1/4"	VNOS24/PM	<input type="checkbox"/>	<input type="checkbox"/>	<input type="checkbox"/>	24.0#
	<ul style="list-style-type: none"> Colored or translucent extruded polypropylene door On-Module overheads mount into slots in vertical posts. Overheads must be same width as panel mounted to. Allows for vertical adjustment in 1" increments 	30 x 17 x 19-1/4"	VNOS30/PM	<input type="checkbox"/>	<input type="checkbox"/>	<input type="checkbox"/>	46.0#
		36 x 17 x 19-1/4"	VNOS36/PM	<input type="checkbox"/>	<input type="checkbox"/>	<input type="checkbox"/>	52.0#
		42 x 17 x 19-1/4"	VNOS42/PM	<input type="checkbox"/>	<input type="checkbox"/>	<input type="checkbox"/>	58.0#
		48 x 17 x 19-1/4"	VNOS48/PM	<input type="checkbox"/>	<input type="checkbox"/>	<input type="checkbox"/>	64.0#
		54 x 17 x 19-1/4"	VNOS54/PM	<input type="checkbox"/>	<input type="checkbox"/>	<input type="checkbox"/>	70.0#
		60 x 17 x 19-1/4"	VNOS60/PM	<input type="checkbox"/>	<input type="checkbox"/>	<input type="checkbox"/>	78.0#
		66 x 17 x 19-1/4"	VNOS66D/PM	<input type="checkbox"/>	<input type="checkbox"/>	<input type="checkbox"/>	92.0#
72 x 17 x 19-1/4"	VNOS72D/PM	<input type="checkbox"/>	<input type="checkbox"/>	<input type="checkbox"/>	116.0#		
<p>VNOKD - KD1/KD2 VNO - Pass Through</p>	Venus® Overhead Cabinet-Solid Color Upper Door-Off-Module (OM12)	24 x 17 x 19-1/4"	VNOS24/PO12	<input type="checkbox"/>	<input type="checkbox"/>	<input type="checkbox"/>	24.0#
	<ul style="list-style-type: none"> Colored or translucent extruded polypropylene door Off-Module overheads mount into an integral track in the horizontal rail. Allows unit to slide along track. Requires 12" tile for mounting (i.e. must be a half or fully segmented panel) 	30 x 17 x 19-1/4"	VNOS30/PO12	<input type="checkbox"/>	<input type="checkbox"/>	<input type="checkbox"/>	46.0#
		36 x 17 x 19-1/4"	VNOS36/PO12	<input type="checkbox"/>	<input type="checkbox"/>	<input type="checkbox"/>	52.0#
		42 x 17 x 19-1/4"	VNOS42/PO12	<input type="checkbox"/>	<input type="checkbox"/>	<input type="checkbox"/>	58.0#
		48 x 17 x 19-1/4"	VNOS48/PO12	<input type="checkbox"/>	<input type="checkbox"/>	<input type="checkbox"/>	64.0#
		54 x 17 x 19-1/4"	VNOS54/PO12	<input type="checkbox"/>	<input type="checkbox"/>	<input type="checkbox"/>	70.0#
		60 x 17 x 19-1/4"	VNOS60/PO12	<input type="checkbox"/>	<input type="checkbox"/>	<input type="checkbox"/>	78.0#
<p>VNOKD - KD1/KD2 VNO - Pass Through</p>	Venus® Overhead Cabinet-Solid Color Upper Door-Off-Module (OM18)	24 x 17 x 19-1/4"	VNOS24/PO18	<input type="checkbox"/>	<input type="checkbox"/>	<input type="checkbox"/>	24.0#
	<ul style="list-style-type: none"> Colored or translucent extruded polypropylene door Off-Module overheads mount into an integral track in the horizontal rail. Allows unit to slide along track. Requires 18" tile for mounting (i.e. must be a half or fully segmented panel) 	30 x 17 x 19-1/4"	VNOS30/PO18	<input type="checkbox"/>	<input type="checkbox"/>	<input type="checkbox"/>	46.0#
		36 x 17 x 19-1/4"	VNOS36/PO18	<input type="checkbox"/>	<input type="checkbox"/>	<input type="checkbox"/>	52.0#
		42 x 17 x 19-1/4"	VNOS42/PO18	<input type="checkbox"/>	<input type="checkbox"/>	<input type="checkbox"/>	58.0#
		48 x 17 x 19-1/4"	VNOS48/PO18	<input type="checkbox"/>	<input type="checkbox"/>	<input type="checkbox"/>	64.0#
		54 x 17 x 19-1/4"	VNOS54/PO18	<input type="checkbox"/>	<input type="checkbox"/>	<input type="checkbox"/>	70.0#
		60 x 17 x 19-1/4"	VNOS60/PO18	<input type="checkbox"/>	<input type="checkbox"/>	<input type="checkbox"/>	78.0#

A **B** **C** **D**

HOW TO ORDER

Indicate the following information on order form:

- Quantity of each item.
- Model number, including options. See "How To Build a Model Number".
- Any special service required.

Note: • The indicates that a choice is required.

- The absence of the indicates that no choice is required.
- Alpha-numeric characters in place of indicate that no other alternatives are available.

HOW TO BUILD A MODEL NUMBER

- A** Select basic model.
- B** Select cabinet paint color. Refer to the **Product Color Options** page in this catalog.
- C** Select upper door color. Refer to the **Product Color Options** page in this catalog.
- D** Select key option.

M	- M series lock
NLC	- No lock core

INFORMATION

Painted cabinet and lower door
Shelf dividers available separately
Cabinet is fully assembled
Door stores above top of cabinet
Will accept hanging tool rail and tackboards
(Attachment bar ordered separately)

Venus® Storage and Accessories

Overhead Storage

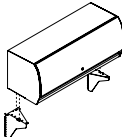
MODEL		W x H x D	MODEL NUMBER				Approx. Packaged Weight
			Basic Model	Cabinet Paint Color	Upper Door Solid Color	Key Option	
 <p>VNOKD - KD1/KD2 VNO - Pass Through</p>	Venus® Overhead Cabinet-Solid Color Upper Door-Load Bar Mount <ul style="list-style-type: none"> Colored or translucent extruded polypropylene door Load Bar Mount overheads hang from an externally mounted load bar Load Bar purchased separately 	24 x 17 x 19-1/4"	VNOS24/LB	<input type="checkbox"/> <input type="checkbox"/> <input type="checkbox"/>	<input type="checkbox"/> <input type="checkbox"/> <input type="checkbox"/>	<input type="checkbox"/> <input type="checkbox"/> <input type="checkbox"/>	24.0#
		30 x 17 x 19-1/4"	VNOS30/LB	<input type="checkbox"/> <input type="checkbox"/> <input type="checkbox"/>	<input type="checkbox"/> <input type="checkbox"/> <input type="checkbox"/>	<input type="checkbox"/> <input type="checkbox"/> <input type="checkbox"/>	46.0#
		36 x 17 x 19-1/4"	VNOS36/LB	<input type="checkbox"/> <input type="checkbox"/> <input type="checkbox"/>	<input type="checkbox"/> <input type="checkbox"/> <input type="checkbox"/>	<input type="checkbox"/> <input type="checkbox"/> <input type="checkbox"/>	52.0#
		42 x 17 x 19-1/4"	VNOS42/LB	<input type="checkbox"/> <input type="checkbox"/> <input type="checkbox"/>	<input type="checkbox"/> <input type="checkbox"/> <input type="checkbox"/>	<input type="checkbox"/> <input type="checkbox"/> <input type="checkbox"/>	58.0#
		48 x 17 x 19-1/4"	VNOS48/LB	<input type="checkbox"/> <input type="checkbox"/> <input type="checkbox"/>	<input type="checkbox"/> <input type="checkbox"/> <input type="checkbox"/>	<input type="checkbox"/> <input type="checkbox"/> <input type="checkbox"/>	64.0#
		54 x 17 x 19-1/4"	VNOS54/LB	<input type="checkbox"/> <input type="checkbox"/> <input type="checkbox"/>	<input type="checkbox"/> <input type="checkbox"/> <input type="checkbox"/>	<input type="checkbox"/> <input type="checkbox"/> <input type="checkbox"/>	70.0#
		60 x 17 x 19-1/4"	VNOS60/LB	<input type="checkbox"/> <input type="checkbox"/> <input type="checkbox"/>	<input type="checkbox"/> <input type="checkbox"/> <input type="checkbox"/>	<input type="checkbox"/> <input type="checkbox"/> <input type="checkbox"/>	78.0#
		66 x 17 x 19-1/4"	VNOS66/LB	<input type="checkbox"/> <input type="checkbox"/> <input type="checkbox"/>	<input type="checkbox"/> <input type="checkbox"/> <input type="checkbox"/>	<input type="checkbox"/> <input type="checkbox"/> <input type="checkbox"/>	92.0#
 <p>VNOKD - KD1/KD2 VNO - Pass Through</p>	Venus® Overhead Cabinet-Solid Color Upper Door - Upmount <ul style="list-style-type: none"> Colored or translucent extruded polypropylene door Upmount brackets position the storage component on a 54" high panel to the same height as on 66" high panels On a 54" high panel, clearance between the cabinet and worksurface is 20" On a 48" high panel, clearance between the cabinet and worksurface is 14" 	24 x 17 x 19-1/4"	VNOS24/UM	<input type="checkbox"/> <input type="checkbox"/> <input type="checkbox"/>	<input type="checkbox"/> <input type="checkbox"/> <input type="checkbox"/>	<input type="checkbox"/> <input type="checkbox"/> <input type="checkbox"/>	24.0#
		30 x 17 x 19-1/4"	VNOS30/UM	<input type="checkbox"/> <input type="checkbox"/> <input type="checkbox"/>	<input type="checkbox"/> <input type="checkbox"/> <input type="checkbox"/>	<input type="checkbox"/> <input type="checkbox"/> <input type="checkbox"/>	46.0#
		36 x 17 x 19-1/4"	VNOS36/UM	<input type="checkbox"/> <input type="checkbox"/> <input type="checkbox"/>	<input type="checkbox"/> <input type="checkbox"/> <input type="checkbox"/>	<input type="checkbox"/> <input type="checkbox"/> <input type="checkbox"/>	52.0#
		42 x 17 x 19-1/4"	VNOS42/UM	<input type="checkbox"/> <input type="checkbox"/> <input type="checkbox"/>	<input type="checkbox"/> <input type="checkbox"/> <input type="checkbox"/>	<input type="checkbox"/> <input type="checkbox"/> <input type="checkbox"/>	58.0#
		48 x 17 x 19-1/4"	VNOS48/UM	<input type="checkbox"/> <input type="checkbox"/> <input type="checkbox"/>	<input type="checkbox"/> <input type="checkbox"/> <input type="checkbox"/>	<input type="checkbox"/> <input type="checkbox"/> <input type="checkbox"/>	64.0#
		54 x 17 x 19-1/4"	VNOS54/UM	<input type="checkbox"/> <input type="checkbox"/> <input type="checkbox"/>	<input type="checkbox"/> <input type="checkbox"/> <input type="checkbox"/>	<input type="checkbox"/> <input type="checkbox"/> <input type="checkbox"/>	70.0#
		60 x 17 x 19-1/4"	VNOS60/UM	<input type="checkbox"/> <input type="checkbox"/> <input type="checkbox"/>	<input type="checkbox"/> <input type="checkbox"/> <input type="checkbox"/>	<input type="checkbox"/> <input type="checkbox"/> <input type="checkbox"/>	78.0#
		66 x 17 x 19-1/4"	VNOS66/UM	<input type="checkbox"/> <input type="checkbox"/> <input type="checkbox"/>	<input type="checkbox"/> <input type="checkbox"/> <input type="checkbox"/>	<input type="checkbox"/> <input type="checkbox"/> <input type="checkbox"/>	92.0#
	72 x 17 x 19-1/4"	VNOS72/UM	<input type="checkbox"/> <input type="checkbox"/> <input type="checkbox"/>	<input type="checkbox"/> <input type="checkbox"/> <input type="checkbox"/>	<input type="checkbox"/> <input type="checkbox"/> <input type="checkbox"/>	116.0#	
			A	B	C	D	

HOW TO ORDER

Indicate the following information on order form:

- Quantity of each item.
- Model number, including options. See "How To Build a Model Number".
- Any special service required.

- Note:
- The indicates that a choice is required.
 - The absence of the indicates that no choice is required.
 - Alpha-numeric characters in place of indicate that no other alternatives are available.

HOW TO BUILD A MODEL NUMBER

- A** Select basic model.
- B** Select cabinet paint color. Refer to the **Product Color Options** page in this catalog.
- C** Select upper door color. Refer to the **Product Color Options** page in this catalog.
- D** Select key option.

M	- M series lock
NLC	- No lock core

INFORMATION

Painted cabinet and lower door
Shelf dividers available separately
Cabinet is fully assembled
Door stores above top of cabinet
Will accept hanging tool rail and tackboards
(Attachment bar ordered separately)

Venus® Storage and Accessories

Overhead Storage

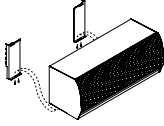
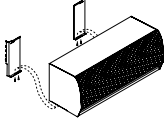
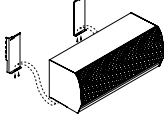
MODEL	W x H x D	MODEL NUMBER				Approx. Packaged Weight
		Basic Model	Cabinet Paint Color	Fabric Color	Key Option	
 <p>VNOSKD - DK1/KD2 VNO - Pass Through</p> <p>Venus® Overhead Cabinet-Fabric Upper Door-On-Module</p> <ul style="list-style-type: none"> On-Module overheads (PM) mount into slots in vertical posts. Overheads must be same width as panel mounted to. Allows for vertical adjustment in 1" increments. 	24 x 17 x 19-1/4"	VNOF24/PM	<input type="checkbox"/> <input type="checkbox"/> <input type="checkbox"/>	<input type="checkbox"/> <input type="checkbox"/> <input type="checkbox"/> <input type="checkbox"/>	<input type="checkbox"/> <input type="checkbox"/> <input type="checkbox"/>	24.0#
	30 x 17 x 19-1/4"	VNOF30/PM	<input type="checkbox"/> <input type="checkbox"/> <input type="checkbox"/>	<input type="checkbox"/> <input type="checkbox"/> <input type="checkbox"/> <input type="checkbox"/>	<input type="checkbox"/> <input type="checkbox"/> <input type="checkbox"/>	46.0#
	36 x 17 x 19-1/4"	VNOF36/PM	<input type="checkbox"/> <input type="checkbox"/> <input type="checkbox"/>	<input type="checkbox"/> <input type="checkbox"/> <input type="checkbox"/> <input type="checkbox"/>	<input type="checkbox"/> <input type="checkbox"/> <input type="checkbox"/>	52.0#
	42 x 17 x 19-1/4"	VNOF42/PM	<input type="checkbox"/> <input type="checkbox"/> <input type="checkbox"/>	<input type="checkbox"/> <input type="checkbox"/> <input type="checkbox"/> <input type="checkbox"/>	<input type="checkbox"/> <input type="checkbox"/> <input type="checkbox"/>	58.0#
	48 x 17 x 19-1/4"	VNOF48/PM	<input type="checkbox"/> <input type="checkbox"/> <input type="checkbox"/>	<input type="checkbox"/> <input type="checkbox"/> <input type="checkbox"/> <input type="checkbox"/>	<input type="checkbox"/> <input type="checkbox"/> <input type="checkbox"/>	64.0#
	54 x 17 x 19-1/4"	VNOF54/PM	<input type="checkbox"/> <input type="checkbox"/> <input type="checkbox"/>	<input type="checkbox"/> <input type="checkbox"/> <input type="checkbox"/> <input type="checkbox"/>	<input type="checkbox"/> <input type="checkbox"/> <input type="checkbox"/>	70.0#
	60 x 17 x 19-1/4"	VNOF60/PM	<input type="checkbox"/> <input type="checkbox"/> <input type="checkbox"/>	<input type="checkbox"/> <input type="checkbox"/> <input type="checkbox"/> <input type="checkbox"/>	<input type="checkbox"/> <input type="checkbox"/> <input type="checkbox"/>	78.0#
	66 x 17 x 19-1/4"	VNOF66/PM	<input type="checkbox"/> <input type="checkbox"/> <input type="checkbox"/>	<input type="checkbox"/> <input type="checkbox"/> <input type="checkbox"/> <input type="checkbox"/>	<input type="checkbox"/> <input type="checkbox"/> <input type="checkbox"/>	92.0#
72 x 17 x 19-1/4"	VNOF72/PM	<input type="checkbox"/> <input type="checkbox"/> <input type="checkbox"/>	<input type="checkbox"/> <input type="checkbox"/> <input type="checkbox"/> <input type="checkbox"/>	<input type="checkbox"/> <input type="checkbox"/> <input type="checkbox"/>	116.0#	
 <p>VNOSKD - DK1/KD2 VNO - Pass Through</p> <p>Venus® Overhead Cabinet-Fabric Upper Door-Off-Module</p> <ul style="list-style-type: none"> Off-Module overheads (OM12) for PowerWorks® mount into an integral track in the horizontal rail. Allows unit to slide along track. Requires a 12" tile for mounting (i.e. must be a half or fully segmented panel) 	24 x 17 x 19-1/4"	VNOF24/PO12	<input type="checkbox"/> <input type="checkbox"/> <input type="checkbox"/>	<input type="checkbox"/> <input type="checkbox"/> <input type="checkbox"/> <input type="checkbox"/>	<input type="checkbox"/> <input type="checkbox"/> <input type="checkbox"/>	24.0#
	30 x 17 x 19-1/4"	VNOF30/PO12	<input type="checkbox"/> <input type="checkbox"/> <input type="checkbox"/>	<input type="checkbox"/> <input type="checkbox"/> <input type="checkbox"/> <input type="checkbox"/>	<input type="checkbox"/> <input type="checkbox"/> <input type="checkbox"/>	46.0#
	36 x 17 x 19-1/4"	VNOF36/PO12	<input type="checkbox"/> <input type="checkbox"/> <input type="checkbox"/>	<input type="checkbox"/> <input type="checkbox"/> <input type="checkbox"/> <input type="checkbox"/>	<input type="checkbox"/> <input type="checkbox"/> <input type="checkbox"/>	52.0#
	42 x 17 x 19-1/4"	VNOF42/PO12	<input type="checkbox"/> <input type="checkbox"/> <input type="checkbox"/>	<input type="checkbox"/> <input type="checkbox"/> <input type="checkbox"/> <input type="checkbox"/>	<input type="checkbox"/> <input type="checkbox"/> <input type="checkbox"/>	58.0#
	48 x 17 x 19-1/4"	VNOF48/PO12	<input type="checkbox"/> <input type="checkbox"/> <input type="checkbox"/>	<input type="checkbox"/> <input type="checkbox"/> <input type="checkbox"/> <input type="checkbox"/>	<input type="checkbox"/> <input type="checkbox"/> <input type="checkbox"/>	64.0#
	54 x 17 x 19-1/4"	VNOF54/PO12	<input type="checkbox"/> <input type="checkbox"/> <input type="checkbox"/>	<input type="checkbox"/> <input type="checkbox"/> <input type="checkbox"/> <input type="checkbox"/>	<input type="checkbox"/> <input type="checkbox"/> <input type="checkbox"/>	70.0#
 <p>VNOSKD - DK1/KD2 VNO - Pass Through</p> <p>Venus® Overhead Cabinet-Fabric Upper Door-Off-Module</p> <ul style="list-style-type: none"> Off-Module overheads (OM18) for PowerWorks® mount into an integral track in the horizontal rail. Allows unit to slide along track. Requires a 18" tile for mounting (i.e. must be a half or fully segmented panel) 	24 x 17 x 19-1/4"	VNOF24/PO18	<input type="checkbox"/> <input type="checkbox"/> <input type="checkbox"/>	<input type="checkbox"/> <input type="checkbox"/> <input type="checkbox"/> <input type="checkbox"/>	<input type="checkbox"/> <input type="checkbox"/> <input type="checkbox"/>	24.0#
	30 x 17 x 19-1/4"	VNOF30/PO18	<input type="checkbox"/> <input type="checkbox"/> <input type="checkbox"/>	<input type="checkbox"/> <input type="checkbox"/> <input type="checkbox"/> <input type="checkbox"/>	<input type="checkbox"/> <input type="checkbox"/> <input type="checkbox"/>	46.0#
	36 x 17 x 19-1/4"	VNOF36/PO18	<input type="checkbox"/> <input type="checkbox"/> <input type="checkbox"/>	<input type="checkbox"/> <input type="checkbox"/> <input type="checkbox"/> <input type="checkbox"/>	<input type="checkbox"/> <input type="checkbox"/> <input type="checkbox"/>	52.0#
	42 x 17 x 19-1/4"	VNOF42/PO18	<input type="checkbox"/> <input type="checkbox"/> <input type="checkbox"/>	<input type="checkbox"/> <input type="checkbox"/> <input type="checkbox"/> <input type="checkbox"/>	<input type="checkbox"/> <input type="checkbox"/> <input type="checkbox"/>	58.0#
	48 x 17 x 19-1/4"	VNOF48/PO18	<input type="checkbox"/> <input type="checkbox"/> <input type="checkbox"/>	<input type="checkbox"/> <input type="checkbox"/> <input type="checkbox"/> <input type="checkbox"/>	<input type="checkbox"/> <input type="checkbox"/> <input type="checkbox"/>	64.0#
	54 x 17 x 19-1/4"	VNOF54/PO18	<input type="checkbox"/> <input type="checkbox"/> <input type="checkbox"/>	<input type="checkbox"/> <input type="checkbox"/> <input type="checkbox"/> <input type="checkbox"/>	<input type="checkbox"/> <input type="checkbox"/> <input type="checkbox"/>	70.0#
60 x 17 x 19-1/4"	VNOF60/PO18	<input type="checkbox"/> <input type="checkbox"/> <input type="checkbox"/>	<input type="checkbox"/> <input type="checkbox"/> <input type="checkbox"/> <input type="checkbox"/>	<input type="checkbox"/> <input type="checkbox"/> <input type="checkbox"/>	78.0#	

A **B** **C** **D**

HOW TO ORDER

Indicate the following information on order form:

- Quantity of each item.
- Model number, including options. See "How To Build a Model Number".
- Any special service required.

Note: • The indicates that a choice is required.

- The absence of the indicates that no choice is required.
- Alpha-numeric characters in place of indicate that no other alternatives are available.

HOW TO BUILD A MODEL NUMBER

- A** Select basic model.
- B** Select cabinet paint color. Refer to the **Product Color Options** page in this catalog.
- C** Select upper door color.
- D** Select key option.

M	- M series lock
NLC	- No lock core

INFORMATION

Painted cabinet and lower door
Shelf dividers available separately
Cabinet is fully assembled
Door stores above top of cabinet
Will accept hanging tool rail and tackboards
(Attachment bar ordered separately)

Venus® Storage and Accessories

Overhead Storage

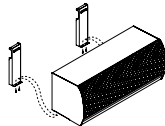
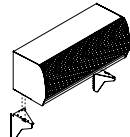
	MODEL	W x H x D	MODEL NUMBER				Approx. Packaged Weight
			Basic Model	Cabinet Paint Color	Fabric Color	Key Option	
 <p>VNOKD - KD1/KD2 VNO - Pass Through</p>	Venus® Overhead Cabinet-Fabric Upper Door-Load Bar Mount <ul style="list-style-type: none"> Load Bar Mount overheads (LB) for PowerWorks® hang from an externally mounted load bar Load Bar purchased separately 	24 x 17 x 19-1/4"	VNOF24/LB	<input type="checkbox"/> <input type="checkbox"/> <input type="checkbox"/>	<input type="checkbox"/> <input type="checkbox"/> <input type="checkbox"/> <input type="checkbox"/>	<input type="checkbox"/> <input type="checkbox"/>	24.0#
		30 x 17 x 19-1/4"	VNOF30/LB	<input type="checkbox"/> <input type="checkbox"/> <input type="checkbox"/>	<input type="checkbox"/> <input type="checkbox"/> <input type="checkbox"/> <input type="checkbox"/>	<input type="checkbox"/> <input type="checkbox"/>	46.0#
		36 x 17 x 19-1/4"	VNOF36/LB	<input type="checkbox"/> <input type="checkbox"/> <input type="checkbox"/>	<input type="checkbox"/> <input type="checkbox"/> <input type="checkbox"/> <input type="checkbox"/>	<input type="checkbox"/> <input type="checkbox"/>	52.0#
		42 x 17 x 19-1/4"	VNOF42/LB	<input type="checkbox"/> <input type="checkbox"/> <input type="checkbox"/>	<input type="checkbox"/> <input type="checkbox"/> <input type="checkbox"/> <input type="checkbox"/>	<input type="checkbox"/> <input type="checkbox"/>	58.0#
		48 x 17 x 19-1/4"	VNOF48/LB	<input type="checkbox"/> <input type="checkbox"/> <input type="checkbox"/>	<input type="checkbox"/> <input type="checkbox"/> <input type="checkbox"/> <input type="checkbox"/>	<input type="checkbox"/> <input type="checkbox"/>	64.0#
		54 x 17 x 19-1/4"	VNOF54/LB	<input type="checkbox"/> <input type="checkbox"/> <input type="checkbox"/>	<input type="checkbox"/> <input type="checkbox"/> <input type="checkbox"/> <input type="checkbox"/>	<input type="checkbox"/> <input type="checkbox"/>	70.0#
		60 x 17 x 19-1/4"	VNOF60/LB	<input type="checkbox"/> <input type="checkbox"/> <input type="checkbox"/>	<input type="checkbox"/> <input type="checkbox"/> <input type="checkbox"/> <input type="checkbox"/>	<input type="checkbox"/> <input type="checkbox"/>	78.0#
		66 x 17 x 19-1/4"	VNOF66/LB	<input type="checkbox"/> <input type="checkbox"/> <input type="checkbox"/>	<input type="checkbox"/> <input type="checkbox"/> <input type="checkbox"/> <input type="checkbox"/>	<input type="checkbox"/> <input type="checkbox"/>	92.0#
	72 x 17 x 19-1/4"	VNOF72/LB	<input type="checkbox"/> <input type="checkbox"/> <input type="checkbox"/>	<input type="checkbox"/> <input type="checkbox"/> <input type="checkbox"/> <input type="checkbox"/>	<input type="checkbox"/> <input type="checkbox"/>	116.0#	
 <p>VNOKD - KD1/KD2 VNO - Pass Through</p>	Venus® Overhead Cabinet-Fabric Upper Door-Upmount <ul style="list-style-type: none"> Upmount brackets position the storage component on a 54" high panel to the same height as on 66" high panels On a 54" high panel, clearance between the cabinet and worksurface is 20" On a 48" high panel, clearance between the cabinet and worksurface is 14" 	24 x 17 x 19-1/4"	VNOF24/UM	<input type="checkbox"/> <input type="checkbox"/> <input type="checkbox"/>	<input type="checkbox"/> <input type="checkbox"/> <input type="checkbox"/> <input type="checkbox"/>	<input type="checkbox"/> <input type="checkbox"/>	24.0#
		30 x 17 x 19-1/4"	VNOF30/UM	<input type="checkbox"/> <input type="checkbox"/> <input type="checkbox"/>	<input type="checkbox"/> <input type="checkbox"/> <input type="checkbox"/> <input type="checkbox"/>	<input type="checkbox"/> <input type="checkbox"/>	46.0#
		36 x 17 x 19-1/4"	VNOF36/UM	<input type="checkbox"/> <input type="checkbox"/> <input type="checkbox"/>	<input type="checkbox"/> <input type="checkbox"/> <input type="checkbox"/> <input type="checkbox"/>	<input type="checkbox"/> <input type="checkbox"/>	52.0#
		42 x 17 x 19-1/4"	VNOF42/UM	<input type="checkbox"/> <input type="checkbox"/> <input type="checkbox"/>	<input type="checkbox"/> <input type="checkbox"/> <input type="checkbox"/> <input type="checkbox"/>	<input type="checkbox"/> <input type="checkbox"/>	58.0#
		48 x 17 x 19-1/4"	VNOF48/UM	<input type="checkbox"/> <input type="checkbox"/> <input type="checkbox"/>	<input type="checkbox"/> <input type="checkbox"/> <input type="checkbox"/> <input type="checkbox"/>	<input type="checkbox"/> <input type="checkbox"/>	64.0#
		54 x 17 x 19-1/4"	VNOF54/UM	<input type="checkbox"/> <input type="checkbox"/> <input type="checkbox"/>	<input type="checkbox"/> <input type="checkbox"/> <input type="checkbox"/> <input type="checkbox"/>	<input type="checkbox"/> <input type="checkbox"/>	70.0#
		60 x 17 x 19-1/4"	VNOF60/UM	<input type="checkbox"/> <input type="checkbox"/> <input type="checkbox"/>	<input type="checkbox"/> <input type="checkbox"/> <input type="checkbox"/> <input type="checkbox"/>	<input type="checkbox"/> <input type="checkbox"/>	78.0#
		66 x 17 x 19-1/4"	VNOF66/UM	<input type="checkbox"/> <input type="checkbox"/> <input type="checkbox"/>	<input type="checkbox"/> <input type="checkbox"/> <input type="checkbox"/> <input type="checkbox"/>	<input type="checkbox"/> <input type="checkbox"/>	92.0#
	72 x 17 x 19-1/4"	VNOF72/UM	<input type="checkbox"/> <input type="checkbox"/> <input type="checkbox"/>	<input type="checkbox"/> <input type="checkbox"/> <input type="checkbox"/> <input type="checkbox"/>	<input type="checkbox"/> <input type="checkbox"/>	116.0#	

A **B** **C** **D**

HOW TO ORDER

Indicate the following information on order form:

- Quantity of each item.
- Model number, including options. See "How To Build a Model Number".
- Any special service required.

Note: • The indicates that a choice is required.
 • The absence of the indicates that no choice is required.
 • Alpha-numeric characters in place of indicate that no other alternatives are available.

HOW TO BUILD A MODEL NUMBER

- A** Select basic model.
- B** Select cabinet paint color. Refer to the **Product Color Options** page in this catalog.
- C** Select upper door color.
- D** Select key option.

M	- M series lock
NLC	- No lock core

INFORMATION

Painted cabinet and lower door
 Shelf dividers available separately
 Cabinet is fully assembled
 Door stores above top of cabinet
 Will accept hanging tool rail and tackboards
 (Attachment bar ordered separately)

Venus® Storage and Accessories

Overhead Storage

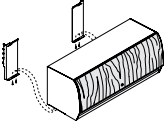
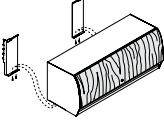
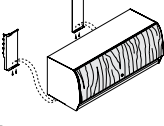
	MODEL	W x H x D	MODEL NUMBER					Approx. Packaged Weight
			Basic Model	Cabinet Paint Color	Laminate Color	Laminate Door Edge Color	Key Option	
 <p>VNOKD - KD1/KD2 VNO - Pass Through</p>	Venus® Overhead Cabinet-Laminate Upper Door-On-Module	24 x 17 x 19-1/4"	VNOL24/PM	<input type="checkbox"/>	<input type="checkbox"/>	<input type="checkbox"/>	<input type="checkbox"/>	24.0#
	<ul style="list-style-type: none"> On-Module overheads (PM) mount into slots in vertical posts. Overheads must be same width as panel mounted to. Allows for vertical adjustment in one-inch increments 	30 x 17 x 19-1/4"	VNOL30/PM	<input type="checkbox"/>	<input type="checkbox"/>	<input type="checkbox"/>	<input type="checkbox"/>	46.0#
		36 x 17 x 19-1/4"	VNOL36/PM	<input type="checkbox"/>	<input type="checkbox"/>	<input type="checkbox"/>	<input type="checkbox"/>	52.0#
		42 x 17 x 19-1/4"	VNOL42/PM	<input type="checkbox"/>	<input type="checkbox"/>	<input type="checkbox"/>	<input type="checkbox"/>	58.0#
		48 x 17 x 19-1/4"	VNOL48/PM	<input type="checkbox"/>	<input type="checkbox"/>	<input type="checkbox"/>	<input type="checkbox"/>	64.0#
		54 x 17 x 19-1/4"	VNOL54/PM	<input type="checkbox"/>	<input type="checkbox"/>	<input type="checkbox"/>	<input type="checkbox"/>	70.0#
		60 x 17 x 19-1/4"	VNOL60/PM	<input type="checkbox"/>	<input type="checkbox"/>	<input type="checkbox"/>	<input type="checkbox"/>	78.0#
		66 x 17 x 19-1/4"	VNOL66/PM	<input type="checkbox"/>	<input type="checkbox"/>	<input type="checkbox"/>	<input type="checkbox"/>	92.0#
		72 x 17 x 19-1/4"	VNOL72/PM	<input type="checkbox"/>	<input type="checkbox"/>	<input type="checkbox"/>	<input type="checkbox"/>	116.0#
 <p>VNOKD - KD1/KD2 VNO - Pass Through</p>	Venus® Overhead Cabinet-Laminate Upper Door-Off-Module	24 x 17 x 19-1/4"	VNOL24/PO12	<input type="checkbox"/>	<input type="checkbox"/>	<input type="checkbox"/>	<input type="checkbox"/>	24.0#
	<ul style="list-style-type: none"> Off-Module overheads (OM12) for PowerWorks® mount into an integral track in the horizontal rail. Allows unit to slide along track. Requires a 12" tile for mounting (i.e. must be a half or fully segmented panel) 	30 x 17 x 19-1/4"	VNOL30/PO12	<input type="checkbox"/>	<input type="checkbox"/>	<input type="checkbox"/>	<input type="checkbox"/>	46.0#
		36 x 17 x 19-1/4"	VNOL36/PO12	<input type="checkbox"/>	<input type="checkbox"/>	<input type="checkbox"/>	<input type="checkbox"/>	52.0#
		42 x 17 x 19-1/4"	VNOL42/PO12	<input type="checkbox"/>	<input type="checkbox"/>	<input type="checkbox"/>	<input type="checkbox"/>	58.0#
		48 x 17 x 19-1/4"	VNOL48/PO12	<input type="checkbox"/>	<input type="checkbox"/>	<input type="checkbox"/>	<input type="checkbox"/>	64.0#
		54 x 17 x 19-1/4"	VNOL54/PO12	<input type="checkbox"/>	<input type="checkbox"/>	<input type="checkbox"/>	<input type="checkbox"/>	70.0#
		60 x 17 x 19-1/4"	VNOL60/PO12	<input type="checkbox"/>	<input type="checkbox"/>	<input type="checkbox"/>	<input type="checkbox"/>	78.0#
 <p>VNOKD - KD1/KD2 VNO - Pass Through</p>	Venus® Overhead Cabinet-Laminate Upper Door-Off-Module	24 x 17 x 19-1/4"	VNOL24/PO18	<input type="checkbox"/>	<input type="checkbox"/>	<input type="checkbox"/>	<input type="checkbox"/>	24.0#
	<ul style="list-style-type: none"> Off-Module overheads (OM18) for PowerWorks® mount into an integral track in the horizontal rail. Allows unit to slide along track. Requires a 18" tile for mounting (i.e. must be a half or fully segmented panel) 	30 x 17 x 19-1/4"	VNOL30/PO18	<input type="checkbox"/>	<input type="checkbox"/>	<input type="checkbox"/>	<input type="checkbox"/>	46.0#
		36 x 17 x 19-1/4"	VNOL36/PO18	<input type="checkbox"/>	<input type="checkbox"/>	<input type="checkbox"/>	<input type="checkbox"/>	52.0#
		42 x 17 x 19-1/4"	VNOL42/PO18	<input type="checkbox"/>	<input type="checkbox"/>	<input type="checkbox"/>	<input type="checkbox"/>	58.0#
		48 x 17 x 19-1/4"	VNOL48/PO18	<input type="checkbox"/>	<input type="checkbox"/>	<input type="checkbox"/>	<input type="checkbox"/>	64.0#
		54 x 17 x 19-1/4"	VNOL54/PO18	<input type="checkbox"/>	<input type="checkbox"/>	<input type="checkbox"/>	<input type="checkbox"/>	70.0#
		60 x 17 x 19-1/4"	VNOL60/PO18	<input type="checkbox"/>	<input type="checkbox"/>	<input type="checkbox"/>	<input type="checkbox"/>	78.0#

A

B

C

D

E

HOW TO ORDER

Indicate the following information on order form:

- Quantity of each item.
- Model number, including options. See "How To Build a Model Number".
- Any special service required.

Note: • The indicates that a choice is required.

- The absence of the indicates that no choice is required.
- Alpha-numeric characters in place of indicate that no other alternatives are available.

HOW TO BUILD A MODEL NUMBER

- A** Select basic model.
- B** Select cabinet paint color.
Refer to the **Product Color Options** page in this catalog.
- C** Select upper door laminate color.
Refer to the **Product Color Options** page in this catalog.
- D** Select laminate door edge color.
Refer to the **Product Color Options** page in this catalog.
- E** Select key option.
- | | |
|------------|-----------------|
| M | - M series lock |
| NLC | - No lock core |

INFORMATION

Painted cabinet and lower door
Shelf dividers available separately
Cabinet is fully assembled
Door stores above top of cabinet
Will accept hanging tool rail and tackboards (Attachment bar ordered separately)

FINISH INFORMATION

Additional Laminate Offering

Additional laminates beyond standard offering, are available with two weeks extended leadtime. To specify additional laminates, use these designators followed by the supplier's color/pattern code:

Formica - LF/supplier's color pattern code
Nevamar - LN/supplier's color pattern code
Wilsonart - LW/supplier's color pattern code

Note: Nonstandard laminates from these suppliers (example: textured laminates), require an additional leadtime.

Venus® Storage and Accessories

Overhead Storage

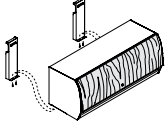
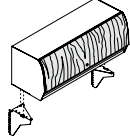
	MODEL	W x H x D	MODEL NUMBER					Approx. Packaged Weight
			Basic Model	Cabinet Paint Color	Laminate Color	Laminate Door Edge Color	Key Option	
 <p>VNOKD - KD1/KD2 VNO - Pass Through</p>	Venus® Overhead Cabinet-Laminate Upper Door-Load Bar Mount	24 x 17 x 19-1/4"	VNOL24/LB	<input type="checkbox"/> <input type="checkbox"/> <input type="checkbox"/>	<input type="checkbox"/> <input type="checkbox"/> <input type="checkbox"/>	<input type="checkbox"/> <input type="checkbox"/> <input type="checkbox"/>	<input type="checkbox"/> <input type="checkbox"/> <input type="checkbox"/>	24.0#
	<ul style="list-style-type: none"> • Load Bar Mount overheads (LB) for PowerWorks® hang from an externally mounted load bar • Load Bar purchased separately 	30 x 17 x 19-1/4"	VNOL30/LB	<input type="checkbox"/> <input type="checkbox"/> <input type="checkbox"/>	<input type="checkbox"/> <input type="checkbox"/> <input type="checkbox"/>	<input type="checkbox"/> <input type="checkbox"/> <input type="checkbox"/>	<input type="checkbox"/> <input type="checkbox"/> <input type="checkbox"/>	46.0#
		36 x 17 x 19-1/4"	VNOL36/LB	<input type="checkbox"/> <input type="checkbox"/> <input type="checkbox"/>	<input type="checkbox"/> <input type="checkbox"/> <input type="checkbox"/>	<input type="checkbox"/> <input type="checkbox"/> <input type="checkbox"/>	<input type="checkbox"/> <input type="checkbox"/> <input type="checkbox"/>	52.0#
		42 x 17 x 19-1/4"	VNOL42/LB	<input type="checkbox"/> <input type="checkbox"/> <input type="checkbox"/>	<input type="checkbox"/> <input type="checkbox"/> <input type="checkbox"/>	<input type="checkbox"/> <input type="checkbox"/> <input type="checkbox"/>	<input type="checkbox"/> <input type="checkbox"/> <input type="checkbox"/>	58.0#
		48 x 17 x 19-1/4"	VNOL48/LB	<input type="checkbox"/> <input type="checkbox"/> <input type="checkbox"/>	<input type="checkbox"/> <input type="checkbox"/> <input type="checkbox"/>	<input type="checkbox"/> <input type="checkbox"/> <input type="checkbox"/>	<input type="checkbox"/> <input type="checkbox"/> <input type="checkbox"/>	64.0#
		54 x 17 x 19-1/4"	VNOL54/LB	<input type="checkbox"/> <input type="checkbox"/> <input type="checkbox"/>	<input type="checkbox"/> <input type="checkbox"/> <input type="checkbox"/>	<input type="checkbox"/> <input type="checkbox"/> <input type="checkbox"/>	<input type="checkbox"/> <input type="checkbox"/> <input type="checkbox"/>	70.0#
		60 x 17 x 19-1/4"	VNOL60/LB	<input type="checkbox"/> <input type="checkbox"/> <input type="checkbox"/>	<input type="checkbox"/> <input type="checkbox"/> <input type="checkbox"/>	<input type="checkbox"/> <input type="checkbox"/> <input type="checkbox"/>	<input type="checkbox"/> <input type="checkbox"/> <input type="checkbox"/>	78.0#
		66 x 17 x 19-1/4"	VNOL66/LB	<input type="checkbox"/> <input type="checkbox"/> <input type="checkbox"/>	<input type="checkbox"/> <input type="checkbox"/> <input type="checkbox"/>	<input type="checkbox"/> <input type="checkbox"/> <input type="checkbox"/>	<input type="checkbox"/> <input type="checkbox"/> <input type="checkbox"/>	92.0#
72 x 17 x 19-1/4"	VNOL72/LB	<input type="checkbox"/> <input type="checkbox"/> <input type="checkbox"/>	<input type="checkbox"/> <input type="checkbox"/> <input type="checkbox"/>	<input type="checkbox"/> <input type="checkbox"/> <input type="checkbox"/>	<input type="checkbox"/> <input type="checkbox"/> <input type="checkbox"/>	116.0#		
 <p>VNOKD - KD1/KD2 VNO - Pass Through</p>	Venus® Overhead Cabinet-Laminate Upper Door-Upmount	24 x 17 x 19-1/4"	VNOL24/UM	<input type="checkbox"/> <input type="checkbox"/> <input type="checkbox"/>	<input type="checkbox"/> <input type="checkbox"/> <input type="checkbox"/>	<input type="checkbox"/> <input type="checkbox"/> <input type="checkbox"/>	<input type="checkbox"/> <input type="checkbox"/> <input type="checkbox"/>	24.0#
	<ul style="list-style-type: none"> • Upmount brackets position the storage component on a 54" high panel to the same height as on 66" high panels • On a 54" high panel, clearance between the cabinet and worksurface is 20" • On a 48" high panel, clearance between the cabinet and worksurface is 14" 	30 x 17 x 19-1/4"	VNOL30/UM	<input type="checkbox"/> <input type="checkbox"/> <input type="checkbox"/>	<input type="checkbox"/> <input type="checkbox"/> <input type="checkbox"/>	<input type="checkbox"/> <input type="checkbox"/> <input type="checkbox"/>	<input type="checkbox"/> <input type="checkbox"/> <input type="checkbox"/>	46.0#
		36 x 17 x 19-1/4"	VNOL36/UM	<input type="checkbox"/> <input type="checkbox"/> <input type="checkbox"/>	<input type="checkbox"/> <input type="checkbox"/> <input type="checkbox"/>	<input type="checkbox"/> <input type="checkbox"/> <input type="checkbox"/>	<input type="checkbox"/> <input type="checkbox"/> <input type="checkbox"/>	52.0#
		42 x 17 x 19-1/4"	VNOL42/UM	<input type="checkbox"/> <input type="checkbox"/> <input type="checkbox"/>	<input type="checkbox"/> <input type="checkbox"/> <input type="checkbox"/>	<input type="checkbox"/> <input type="checkbox"/> <input type="checkbox"/>	<input type="checkbox"/> <input type="checkbox"/> <input type="checkbox"/>	58.0#
		48 x 17 x 19-1/4"	VNOL48/UM	<input type="checkbox"/> <input type="checkbox"/> <input type="checkbox"/>	<input type="checkbox"/> <input type="checkbox"/> <input type="checkbox"/>	<input type="checkbox"/> <input type="checkbox"/> <input type="checkbox"/>	<input type="checkbox"/> <input type="checkbox"/> <input type="checkbox"/>	64.0#
		54 x 17 x 19-1/4"	VNOL54/UM	<input type="checkbox"/> <input type="checkbox"/> <input type="checkbox"/>	<input type="checkbox"/> <input type="checkbox"/> <input type="checkbox"/>	<input type="checkbox"/> <input type="checkbox"/> <input type="checkbox"/>	<input type="checkbox"/> <input type="checkbox"/> <input type="checkbox"/>	70.0#
		60 x 17 x 19-1/4"	VNOL60/UM	<input type="checkbox"/> <input type="checkbox"/> <input type="checkbox"/>	<input type="checkbox"/> <input type="checkbox"/> <input type="checkbox"/>	<input type="checkbox"/> <input type="checkbox"/> <input type="checkbox"/>	<input type="checkbox"/> <input type="checkbox"/> <input type="checkbox"/>	78.0#
		66 x 17 x 19-1/4"	VNOL66/UM	<input type="checkbox"/> <input type="checkbox"/> <input type="checkbox"/>	<input type="checkbox"/> <input type="checkbox"/> <input type="checkbox"/>	<input type="checkbox"/> <input type="checkbox"/> <input type="checkbox"/>	<input type="checkbox"/> <input type="checkbox"/> <input type="checkbox"/>	92.0#
72 x 17 x 19-1/4"	VNOL72/UM	<input type="checkbox"/> <input type="checkbox"/> <input type="checkbox"/>	<input type="checkbox"/> <input type="checkbox"/> <input type="checkbox"/>	<input type="checkbox"/> <input type="checkbox"/> <input type="checkbox"/>	<input type="checkbox"/> <input type="checkbox"/> <input type="checkbox"/>	116.0#		

A **B** **C** **D** **E**

HOW TO ORDER

Indicate the following information on order form:

1. Quantity of each item.
2. Model number, including options. See "How To Build a Model Number".
3. Any special service required.

Note: • The indicates that a choice is required.
 • The absence of the indicates that no choice is required.
 • Alpha-numeric characters in place of indicate that no other alternatives are available.

HOW TO BUILD A MODEL NUMBER

- A** Select basic model.
- B** Select cabinet paint color.
Refer to the **Product Color Options** page in this catalog.
- C** Select upper door laminate color.
Refer to the **Product Color Options** page in this catalog.
- D** Select laminate door edge color.
Refer to the **Product Color Options** page in this catalog.
- E** Select key option.

M	- M series lock
NLC	- No lock core

INFORMATION

Painted cabinet and lower door
 Shelf dividers available separately
 Cabinet is fully assembled
 Door stores above top of cabinet
 Will accept hanging tool rail and tackboards
 (Attachment bar ordered separately)

Venus® Storage and Accessories

Overhead Accessories

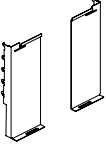
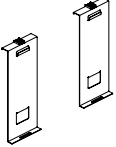
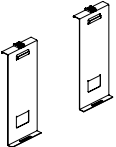
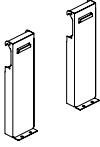
	MODEL	MODEL NUMBER		Approx. Packaged Weight
		Basic Model	Trim Color	
 <p>BOA</p>	Venus® Overhead On-Module Mounting Bracket <ul style="list-style-type: none"> • Sold in pairs • Mounts into slots in vertical posts • Black only 	BOA/PM		5.0#
 <p>BOA</p>	Venus® Overhead Off-Module Mounting Bracket-12" Tiles <ul style="list-style-type: none"> • Sold in pairs • Mounts into slots in vertical posts • Black only 	BOA/OM12		5.0#
 <p>BOA</p>	Venus® Overhead Off-Module Mounting Bracket-18" Tiles <ul style="list-style-type: none"> • Sold in pairs • Mounts into slots in vertical posts • Black only 	BOA/OM18		5.0#
 <p>BOA</p>	Load Bar Brackets <ul style="list-style-type: none"> • Load Bar mount overheads (LB) for PowerWorks® hang from an externally mounted load bar • Load Bar purchased separately • Sold in pairs 	BOA/LB	<input type="checkbox"/> <input type="checkbox"/>	5.0#

A

B

HOW TO ORDER

Indicate the following information on order form:

1. Quantity of each item.
2. Model number, including options. See "How To Build a Model Number".
3. Any special service required.

Note: • The indicates that a choice is required.

- The absence of the indicates that no choice is required.
- Alpha-numeric characters in place of indicate that no other alternatives are available.

HOW TO BUILD A MODEL NUMBER

- A** Select basic model.
- B** Select trim color. Refer to the **Product Color Options** page in this catalog.

Venus® Storage and Accessories

Overhead Accessories

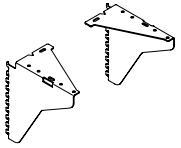
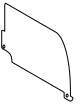
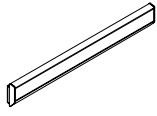
	MODEL	W	MODEL NUMBER		Approx. Packaged Weight
			Basic Model	Paint Color	
 BOA	Upmount Brackets • Upmount brackets position the storage component on a 54" high panel to the same height as on 66" high panels • Sold in pairs		BOA/UM	<input type="checkbox"/>	5.0#
 HRDPT	Shelf Dividers • Steel shelf dividers with powder coat finish • Fits on all shelves and cabinets	7-1/4 x 11-1/2"	NSD	<input type="checkbox"/>	1.0#
 HRDPT	Wall Mounted Load Bar	24"	SWLB.24	<input type="checkbox"/>	5.0#
		30"	SWLB.30	<input type="checkbox"/>	6.0#
		36"	SWLB.36	<input type="checkbox"/>	7.0#
		42"	SWLB.42	<input type="checkbox"/>	8.0#
		48"	SWLB.48	<input type="checkbox"/>	10.0#
		54"	SWLB.54	<input type="checkbox"/>	13.0#
		60"	SWLB.60	<input type="checkbox"/>	12.0#
		66"	SWLB.66	<input type="checkbox"/>	13.0#
		72"	SWLB.72	<input type="checkbox"/>	14.0#
		84"	SWLB.84	<input type="checkbox"/>	17.0#
		96"	SWLB.96	<input type="checkbox"/>	19.0#

A

B

HOW TO ORDER

Indicate the following information on order form:

1. Quantity of each item.
2. Model number, including options. See "How To Build a Model Number".
3. Any special service required.



Note: • The indicates that a choice is required.
 • The absence of the indicates that no choice is required.
 • Alpha-numeric characters in place of indicate that no other alternatives are available.

HOW TO BUILD A MODEL NUMBER

- A** Select basic model.
- B** Select paint color.
 Refer to the **Product Color Options** page in this catalog.

Venus® Storage and Accessories

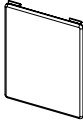
Overhead Accessories

	MODEL	W x H	MODEL NUMBER			Approx. Packaged Weight
			Basic Model	Trim Color	Fabric Color	
 PTBO	Overhead Tackboard	24 x 12"	PTB02412	<input type="checkbox"/>	<input type="checkbox"/>	3.0#
	• Hangs from bottom of flipper door cabinet or shelf	30 x 12"	PTB03012	<input type="checkbox"/>	<input type="checkbox"/>	3.0#
	• When hanging from Venus® overhead, specify attachment bar BMB (purchase separately)	36 x 12"	PTB03612	<input type="checkbox"/>	<input type="checkbox"/>	3.0#
		42 x 12"	PTB04212	<input type="checkbox"/>	<input type="checkbox"/>	4.0#
		48 x 12"	PTB04812	<input type="checkbox"/>	<input type="checkbox"/>	4.0#
	• Includes mounting brackets in black only	54 x 12"	PTB05412	<input type="checkbox"/>	<input type="checkbox"/>	4.0#
	• Specify 20" high tackboard to cover vertical space between bottom of overhead and top of worksurface, when worksurface is positioned at 29" above finished floor	60 x 12"	PTB06012	<input type="checkbox"/>	<input type="checkbox"/>	4.0#
		24 x 16"	PTB02416	<input type="checkbox"/>	<input type="checkbox"/>	3.0#
		30 x 16"	PTB03016	<input type="checkbox"/>	<input type="checkbox"/>	4.0#
		36 x 16"	PTB03616	<input type="checkbox"/>	<input type="checkbox"/>	4.0#
		42 x 16"	PTB04216	<input type="checkbox"/>	<input type="checkbox"/>	5.0#
		48 x 16"	PTB04816	<input type="checkbox"/>	<input type="checkbox"/>	5.0#
		54 x 16"	PTB05416	<input type="checkbox"/>	<input type="checkbox"/>	6.0#
		60 x 16"	PTB06016	<input type="checkbox"/>	<input type="checkbox"/>	6.0#
		24 x 20"	PTB02420	<input type="checkbox"/>	<input type="checkbox"/>	4.0#
		30 x 20"	PTB03020	<input type="checkbox"/>	<input type="checkbox"/>	5.0#
		36 x 20"	PTB03620	<input type="checkbox"/>	<input type="checkbox"/>	6.0#
		42 x 20"	PTB04220	<input type="checkbox"/>	<input type="checkbox"/>	7.0#
		48 x 20"	PTB04820	<input type="checkbox"/>	<input type="checkbox"/>	8.0#
		54 x 20"	PTB05420	<input type="checkbox"/>	<input type="checkbox"/>	9.0#
	60 x 20"	PTB06020	<input type="checkbox"/>	<input type="checkbox"/>	10.0#	
 BOA	Tackboard/Tool Rail Attachment Bar	30"	BMB30	BL		3.0#
	• Attachment bracket that attaches to bottom of overhead to accept overhead tackboard	36"	BMB36	BL		3.0#
		42"	BMB42	BL		3.0#
	• Order same size as overhead cabinet	48"	BMB48	BL		4.0#
	• 18-gauge steel	54"	BMB54	BL		4.0#
	• Black only	60"	BMB60	BL		4.0#

A

B

C

HOW TO ORDER

Indicate the following information on order form:

- Quantity of each item.
- Model number, including options. See "How To Build a Model Number".
- Any special service required.

Note: • The indicates that a choice is required.

- The absence of the indicates that no choice is required.
- Alpha-numeric characters in place of indicate that no other alternatives are available.

HOW TO BUILD A MODEL NUMBER

- A** Select basic model.
- B** Select trim color.
Refer to the **Product Color Options** page in this catalog.
- C** Select fabric color.

Venus® Storage and Accessories

Overhead Task Light

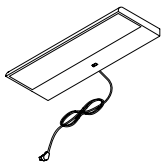
	MODEL	W	MODEL NUMBER		Approx. Packaged Weight
			Basic Model		
 <p>HRDPT</p>	Overhead Task Light	18"	BTLT5.18		3.4#
	• Attaches to the bottom of overhead storage cabinet	24"	BTLT5.24		3.9#
	• Task lights are specified by the cabinet width to which they are attached. See "INFORMATION" at bottom of PO Catalog page for sizing chart.	36"	BTLT5.36		5.3#
	• Attachment hardware included	48"	BTLT5.48		6.7#
	• Electronic NPF ballast				
	• T5 Florescent bulb				
	• Center located, 9' cord with 90 degree, 3 prong plug				
	• Center located, two position rocker switch				
	• Cord and power switch on 24" wide located left of center				
	• Standard color of casing is black				

A

HOW TO ORDER

Indicate the following information on order form:

- Quantity of each item.
- Model number, including options. See "How To Build a Model Number".
- Any special service required.

Note: • The indicates that a choice is required.

- The absence of the indicates that no choice is required.
- Alpha-numeric characters in place of indicate that no other alternatives are available.

HOW TO BUILD A MODEL NUMBER

A Select basic model.

INFORMATION

TASK LIGHT CABINET WIDTH

Cabinet Width	Light Width
24"	18"
30"	24"
36"	24"
42"	36"
48"	36"
54"	48"
60"	48"

Accessories

Markerboards

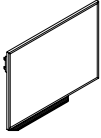
	MODEL	Features	W x H	MODEL NUMBER	Approx. Packaged Weight	
				Basic Model		
 <p>HRDPT</p> <p>Markerboards</p> <ul style="list-style-type: none"> • White porcelain painted steel surface with matching white trim • Includes magnetic removable 16" x 2-1/2" tray with markers and eraser • Specify for "on" or "off" module mounting brackets • Includes black mounting brackets 		Off-Module	30 x 32"	PMB.OM.3032	11.0#	
		Off-Module	36 x 32"	PMB.OM.3632	13.0#	
		Off-Module	42 x 32"	PMB.OM.4232	15.0#	
		Off-Module	48 x 32"	PMB.OM.4832	17.0#	
		Off-Module	54 x 32"	PMB.OM.5432	20.0#	
		Off-Module	60 x 32"	PMB.OM.6032	22.0#	
		On-Module	30 x 32"	PMB.PM.3032	11.0#	
		On-Module	36 x 32"	PMB.PM.3632	13.0#	
		On-Module	42 x 32"	PMB.PM.4232	15.0#	
		On-Module	48 x 32"	PMB.PM.4832	17.0#	
		On-Module	54 x 32"	PMB.PM.5432	20.0#	
		On-Module	60 x 32"	PMB.PM.6032	22.0#	

A

HOW TO ORDER

Indicate the following information on order form:

1. Quantity of each item.
2. Model number, including options. See "How To Build a Model Number".
3. Any special service required.

Note: • The indicates that a choice is required.

- The absence of the indicates that no choice is required.
- Alpha-numeric characters in place of indicate that no other alternatives are available.

HOW TO BUILD A MODEL NUMBER

A Select basic model.

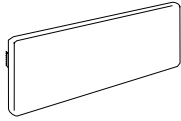

P1TB - KD1
PTB - Pass Through

MODEL

Tackboard

- Tackboards are constructed of 3/4" tackable core and covered with fabric
- Includes black mounting brackets
- Not available with countertops

Features W x H

MODEL NUMBER

Basic Model

Fabric Color

Approx. Packaged Weight

Features	W x H	Basic Model	Fabric Color	Approx. Packaged Weight
Off-Module 24 x 12"	PTB2412/OM	<input type="checkbox"/> <input type="checkbox"/> <input type="checkbox"/> <input type="checkbox"/>	3.0#	
Off-Module 30 x 12"	PTB3012/OM	<input type="checkbox"/> <input type="checkbox"/> <input type="checkbox"/> <input type="checkbox"/>	3.0#	
Off-Module 36 x 12"	PTB3612/OM	<input type="checkbox"/> <input type="checkbox"/> <input type="checkbox"/> <input type="checkbox"/>	4.0#	
Off-Module 42 x 12"	PTB4212/OM	<input type="checkbox"/> <input type="checkbox"/> <input type="checkbox"/> <input type="checkbox"/>	4.0#	
Off-Module 48 x 12"	PTB4812/OM	<input type="checkbox"/> <input type="checkbox"/> <input type="checkbox"/> <input type="checkbox"/>	5.0#	
Off-Module 54 x 12"	PTB5412/OM	<input type="checkbox"/> <input type="checkbox"/> <input type="checkbox"/> <input type="checkbox"/>	5.0#	
Off-Module 60 x 12"	PTB6012/OM	<input type="checkbox"/> <input type="checkbox"/> <input type="checkbox"/> <input type="checkbox"/>	6.0#	
Off-Module 24 x 16"	PTB2416/OM	<input type="checkbox"/> <input type="checkbox"/> <input type="checkbox"/> <input type="checkbox"/>	4.0#	
Off-Module 30 x 16"	PTB3016/OM	<input type="checkbox"/> <input type="checkbox"/> <input type="checkbox"/> <input type="checkbox"/>	4.0#	
Off-Module 36 x 16"	PTB3616/OM	<input type="checkbox"/> <input type="checkbox"/> <input type="checkbox"/> <input type="checkbox"/>	5.0#	
Off-Module 42 x 16"	PTB4216/OM	<input type="checkbox"/> <input type="checkbox"/> <input type="checkbox"/> <input type="checkbox"/>	5.0#	
Off-Module 48 x 16"	PTB4816/OM	<input type="checkbox"/> <input type="checkbox"/> <input type="checkbox"/> <input type="checkbox"/>	6.0#	
Off-Module 54 x 16"	PTB5416/OM	<input type="checkbox"/> <input type="checkbox"/> <input type="checkbox"/> <input type="checkbox"/>	6.0#	
Off-Module 60 x 16"	PTB6016/OM	<input type="checkbox"/> <input type="checkbox"/> <input type="checkbox"/> <input type="checkbox"/>	7.0#	
On-Module 24 x 12"	PTB2412/PM	<input type="checkbox"/> <input type="checkbox"/> <input type="checkbox"/> <input type="checkbox"/>	3.0#	
On-Module 30 x 12"	PTB3012/PM	<input type="checkbox"/> <input type="checkbox"/> <input type="checkbox"/> <input type="checkbox"/>	3.0#	
On-Module 36 x 12"	PTB3612/PM	<input type="checkbox"/> <input type="checkbox"/> <input type="checkbox"/> <input type="checkbox"/>	4.0#	
On-Module 42 x 12"	PTB4212/PM	<input type="checkbox"/> <input type="checkbox"/> <input type="checkbox"/> <input type="checkbox"/>	4.0#	
On-Module 48 x 12"	PTB4812/PM	<input type="checkbox"/> <input type="checkbox"/> <input type="checkbox"/> <input type="checkbox"/>	5.0#	
On-Module 54 x 12"	PTB5412/PM	<input type="checkbox"/> <input type="checkbox"/> <input type="checkbox"/> <input type="checkbox"/>	5.0#	
On-Module 60 x 12"	PTB6012/PM	<input type="checkbox"/> <input type="checkbox"/> <input type="checkbox"/> <input type="checkbox"/>	6.0#	
On-Module 24 x 16"	PTB2416/PM	<input type="checkbox"/> <input type="checkbox"/> <input type="checkbox"/> <input type="checkbox"/>	4.0#	
On-Module 30 x 16"	PTB3016/PM	<input type="checkbox"/> <input type="checkbox"/> <input type="checkbox"/> <input type="checkbox"/>	4.0#	
On-Module 36 x 16"	PTB3616/PM	<input type="checkbox"/> <input type="checkbox"/> <input type="checkbox"/> <input type="checkbox"/>	5.0#	
On-Module 42 x 16"	PTB4216/PM	<input type="checkbox"/> <input type="checkbox"/> <input type="checkbox"/> <input type="checkbox"/>	5.0#	
On-Module 48 x 16"	PTB4816/PM	<input type="checkbox"/> <input type="checkbox"/> <input type="checkbox"/> <input type="checkbox"/>	6.0#	
On-Module 54 x 16"	PTB5416/PM	<input type="checkbox"/> <input type="checkbox"/> <input type="checkbox"/> <input type="checkbox"/>	6.0#	
On-Module 60 x 16"	PTB6016/PM	<input type="checkbox"/> <input type="checkbox"/> <input type="checkbox"/> <input type="checkbox"/>	7.0#	

A

B

HOW TO ORDER

Indicate the following information on order form:

1. Quantity of each item.
2. Model number, including options. See "How To Build a Model Number".
3. Any special service required.

- Note:
- The indicates that a choice is required.
 - The absence of the indicates that no choice is required.
 - Alpha-numeric characters in place of indicate that no other alternatives are available.

HOW TO BUILD A MODEL NUMBER

A Select basic model.

B Select fabric color.

Accessories

Tackboard

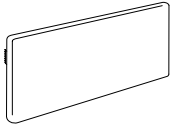

P1TB - KD1
PTB - Pass Through

- Tackboard**
- Tackboards are constructed of 3/4" tackable core and covered with fabric
 - Includes black mounting brackets
 - Not available with countertops

MODEL	Features	W x H	MODEL NUMBER		Approx. Packaged Weight
			Basic Model	Fabric Color	
Off-Module	24 x 20"	PTB2420/OM	<input type="checkbox"/> <input type="checkbox"/> <input type="checkbox"/> <input type="checkbox"/>	4.0#	
Off-Module	30 x 20"	PTB3020/OM	<input type="checkbox"/> <input type="checkbox"/> <input type="checkbox"/> <input type="checkbox"/>	5.0#	
Off-Module	36 x 20"	PTB3620/OM	<input type="checkbox"/> <input type="checkbox"/> <input type="checkbox"/> <input type="checkbox"/>	6.0#	
Off-Module	42 x 20"	PTB4220/OM	<input type="checkbox"/> <input type="checkbox"/> <input type="checkbox"/> <input type="checkbox"/>	7.0#	
Off-Module	48 x 20"	PTB4820/OM	<input type="checkbox"/> <input type="checkbox"/> <input type="checkbox"/> <input type="checkbox"/>	8.0#	
Off-Module	54 x 20"	PTB5420/OM	<input type="checkbox"/> <input type="checkbox"/> <input type="checkbox"/> <input type="checkbox"/>	9.0#	
Off-Module	60 x 20"	PTB6020/OM	<input type="checkbox"/> <input type="checkbox"/> <input type="checkbox"/> <input type="checkbox"/>	10.0#	
Off-Module	24 x 30"	PTB2430/OM	<input type="checkbox"/> <input type="checkbox"/> <input type="checkbox"/> <input type="checkbox"/>	6.0#	
Off-Module	30 x 30"	PTB3030/OM	<input type="checkbox"/> <input type="checkbox"/> <input type="checkbox"/> <input type="checkbox"/>	7.0#	
Off-Module	36 x 30"	PTB3630/OM	<input type="checkbox"/> <input type="checkbox"/> <input type="checkbox"/> <input type="checkbox"/>	8.0#	
Off-Module	42 x 30"	PTB4230/OM	<input type="checkbox"/> <input type="checkbox"/> <input type="checkbox"/> <input type="checkbox"/>	10.0#	
Off-Module	48 x 30"	PTB4830/OM	<input type="checkbox"/> <input type="checkbox"/> <input type="checkbox"/> <input type="checkbox"/>	11.0#	
Off-Module	54 x 30"	PTB5430/OM	<input type="checkbox"/> <input type="checkbox"/> <input type="checkbox"/> <input type="checkbox"/>	12.0#	
Off-Module	60 x 30"	PTB6030/OM	<input type="checkbox"/> <input type="checkbox"/> <input type="checkbox"/> <input type="checkbox"/>	14.0#	
On-Module	24 x 20"	PTB2420/PM	<input type="checkbox"/> <input type="checkbox"/> <input type="checkbox"/> <input type="checkbox"/>	4.0#	
On-Module	30 x 20"	PTB3020/PM	<input type="checkbox"/> <input type="checkbox"/> <input type="checkbox"/> <input type="checkbox"/>	5.0#	
On-Module	36 x 20"	PTB3620/PM	<input type="checkbox"/> <input type="checkbox"/> <input type="checkbox"/> <input type="checkbox"/>	6.0#	
On-Module	42 x 20"	PTB4220/PM	<input type="checkbox"/> <input type="checkbox"/> <input type="checkbox"/> <input type="checkbox"/>	7.0#	
On-Module	48 x 20"	PTB4820/PM	<input type="checkbox"/> <input type="checkbox"/> <input type="checkbox"/> <input type="checkbox"/>	8.0#	
On-Module	54 x 20"	PTB5420/PM	<input type="checkbox"/> <input type="checkbox"/> <input type="checkbox"/> <input type="checkbox"/>	9.0#	
On-Module	60 x 20"	PTB6020/PM	<input type="checkbox"/> <input type="checkbox"/> <input type="checkbox"/> <input type="checkbox"/>	10.0#	
On-Module	24 x 30"	PTB2430/PM	<input type="checkbox"/> <input type="checkbox"/> <input type="checkbox"/> <input type="checkbox"/>	6.0#	
On-Module	30 x 30"	PTB3030/PM	<input type="checkbox"/> <input type="checkbox"/> <input type="checkbox"/> <input type="checkbox"/>	7.0#	
On-Module	36 x 30"	PTB3630/PM	<input type="checkbox"/> <input type="checkbox"/> <input type="checkbox"/> <input type="checkbox"/>	8.0#	
On-Module	42 x 30"	PTB4230/PM	<input type="checkbox"/> <input type="checkbox"/> <input type="checkbox"/> <input type="checkbox"/>	10.0#	
On-Module	48 x 30"	PTB4830/PM	<input type="checkbox"/> <input type="checkbox"/> <input type="checkbox"/> <input type="checkbox"/>	11.0#	
On-Module	54 x 30"	PTB5430/PM	<input type="checkbox"/> <input type="checkbox"/> <input type="checkbox"/> <input type="checkbox"/>	12.0#	
On-Module	60 x 30"	PTB6030/PM	<input type="checkbox"/> <input type="checkbox"/> <input type="checkbox"/> <input type="checkbox"/>	14.0#	

A

B

HOW TO ORDER

Indicate the following information on order form:

1. Quantity of each item.
2. Model number, including options. See "How To Build a Model Number".
3. Any special service required.

Note: • The indicates that a choice is required.

- The absence of the indicates that no choice is required.

- Alpha-numeric characters in place of indicate that no other alternatives are available.

HOW TO BUILD A MODEL NUMBER

A Select basic model.

B Select fabric color.

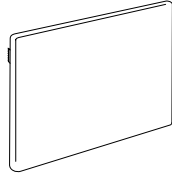

P1TB - KD1

PTB - Pass Through

MODEL**Tackboard**

- Tackboards are constructed of 3/4" tackable core and covered with fabric
- Includes mounting brackets
- Not available with countertops

Features**W x H****MODEL NUMBER**

Basic Model

Fabric Color

Approx. Packaged Weight

Features	W x H	Basic Model	Fabric Color	Approx. Packaged Weight
Off-Module	24 x 48"	PTB2448/OM	<input type="checkbox"/> <input type="checkbox"/> <input type="checkbox"/> <input type="checkbox"/>	9.0#
Off-Module	30 x 48"	PTB3048/OM	<input type="checkbox"/> <input type="checkbox"/> <input type="checkbox"/> <input type="checkbox"/>	11.0#
Off-Module	36 x 48"	PTB3648/OM	<input type="checkbox"/> <input type="checkbox"/> <input type="checkbox"/> <input type="checkbox"/>	13.0#
Off-Module	42 x 48"	PTB4248/OM	<input type="checkbox"/> <input type="checkbox"/> <input type="checkbox"/> <input type="checkbox"/>	15.0#
Off-Module	48 x 48"	PTB4848/OM	<input type="checkbox"/> <input type="checkbox"/> <input type="checkbox"/> <input type="checkbox"/>	17.0#
Off-Module	54 x 48"	PTB5448/OM	<input type="checkbox"/> <input type="checkbox"/> <input type="checkbox"/> <input type="checkbox"/>	19.0#
On-Module	24 x 48"	PTB2448/PM	<input type="checkbox"/> <input type="checkbox"/> <input type="checkbox"/> <input type="checkbox"/>	9.0#
On-Module	30 x 48"	PTB3048/PM	<input type="checkbox"/> <input type="checkbox"/> <input type="checkbox"/> <input type="checkbox"/>	11.0#
On-Module	36 x 48"	PTB3648/PM	<input type="checkbox"/> <input type="checkbox"/> <input type="checkbox"/> <input type="checkbox"/>	13.0#
On-Module	42 x 48"	PTB4248/PM	<input type="checkbox"/> <input type="checkbox"/> <input type="checkbox"/> <input type="checkbox"/>	15.0#
On-Module	48 x 48"	PTB4848/PM	<input type="checkbox"/> <input type="checkbox"/> <input type="checkbox"/> <input type="checkbox"/>	17.0#
On-Module	54 x 48"	PTB5448/PM	<input type="checkbox"/> <input type="checkbox"/> <input type="checkbox"/> <input type="checkbox"/>	19.0#

A**B****HOW TO ORDER**

Indicate the following information on order form:

1. Quantity of each item.
2. Model number, including options. See "How To Build a Model Number".
3. Any special service required.

Note: • The indicates that a choice is required.

- The absence of the indicates that no choice is required.
- Alpha-numeric characters in place of indicate that no other alternatives are available.

HOW TO BUILD A MODEL NUMBER

A Select basic model.

B Select fabric color.

Accessories

Brackets

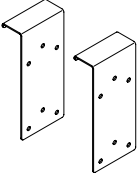
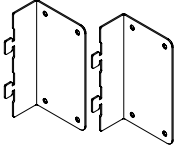
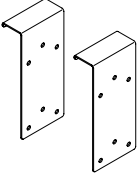
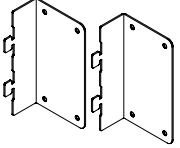
MODEL	MODEL NUMBER		Approx. Packaged Weight
	Basic Model		
 <p>Tackboard Off-Module Bracket</p> <ul style="list-style-type: none"> • Pair of brackets • Order one kit for all heights • Includes mounting hardware • Not used on Overhead Tackboards • Only necessary to order if changing mounting style • Black only 	46.0371.TB.KIT		1.0#
HRDPT			
 <p>Tackboard On-Module Bracket</p> <ul style="list-style-type: none"> • Order one kit for 12" and 16" high tackboards • Order two kits for 20" and 30" high tackboards • Order three kits for 48" high tackboards • Not used on Overhead Tackboards • Only necessary to order if changing mounting style • Black only 	46.0078.TB.KIT		1.0#
HRDPT			
 <p>Markerboard Off-Module Bracket</p> <ul style="list-style-type: none"> • Pair of brackets • Order one kit for all heights • Includes mounting hardware • Only necessary to order if changing mounting style • Black only 	46.0371.MB.KIT		1.0#
HRDPT			
 <p>Markerboard On-Module Bracket</p> <ul style="list-style-type: none"> • Pair of brackets • Order one kit for all heights • Includes mounting hardware • Only necessary to order if changing mounting style • Black only 	46.0078.MB.KIT		1.0#
HRDPT			

A

HOW TO ORDER

Indicate the following information on order form:



1. Quantity of each item.
2. Model number, including options. See "How To Build a Model Number".
3. Any special service required.

Note: • The indicates that a choice is required.

- The absence of the indicates that no choice is required.
- Alpha-numeric characters in place of indicate that no other alternatives are available.

HOW TO BUILD A MODEL NUMBER

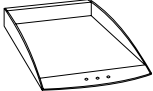
- A** Select basic model.

	MODEL	H x W x D	MODEL NUMBER		Approx. Packaged Weight
			Basic Model	Trim Color	
 PTR	On-Module Tool Rail <ul style="list-style-type: none"> Accommodates paper management components Attaches to panels "on" module Field installable Painted aluminum construction Consists of four slots to accept components 	12 x 4 1/2"	PPMTR12	<input type="checkbox"/>	3.0#
		18 x 4 1/2"	PPMTR18	<input type="checkbox"/>	3.0#
		24 x 4 1/2"	PPMTR24	<input type="checkbox"/>	3.0#
		30 x 4 1/2"	PPMTR30	<input type="checkbox"/>	4.0#
		36 x 4 1/2"	PPMTR36	<input type="checkbox"/>	5.0#
		42 x 4 1/2"	PPMTR42	<input type="checkbox"/>	6.0#
		48 x 4 1/2"	PPMTR48	<input type="checkbox"/>	6.0#
		54 x 4 1/2"	PPMTR54	<input type="checkbox"/>	7.0#
		60 x 4 1/2"	PPMTR60	<input type="checkbox"/>	7.0#
		72 x 4 1/2"	PPMTR72	<input type="checkbox"/>	8.0#
 HRDPT	Plastic Paper Tray Unit <ul style="list-style-type: none"> Plastic construction Accepts letter and legal-size paper Suspends from Tool Rail 	2 x 9-1/2 x 14"	PPLL	<input type="checkbox"/>	1.0#
 HRDPT	Plastic Diagonal Storage Unit <ul style="list-style-type: none"> Plastic construction Three slanted partitions per unit with dividers Suspends from Tool Rail 	2-1/2 x 7 x 12-1/2"	PPDS	<input type="checkbox"/>	4.0#
 HRDPT	Plastic Vertical Storage Unit <ul style="list-style-type: none"> Injection-molded plastic construction Stores binders and books Suspends from Tool Rail 	9 x 5 x 10-1/2"	PPVS	<input type="checkbox"/>	1.0#

A

B

HOW TO ORDER

Indicate the following information on order form:

- Quantity of each item.
- Model number, including options. See "How To Build a Model Number".
- Any special service required.

Note: • The indicates that a choice is required.

- The absence of the indicates that no choice is required.
- Alpha-numeric characters in place of indicate that no other alternatives are available.



HOW TO BUILD A MODEL NUMBER

A Select basic model.

B Select trim color.
Refer to the **Product Color Options** page in this catalog.

Accessories

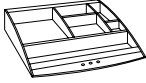
Desktop Accessories

	MODEL	H x W x D	MODEL NUMBER		Approx. Packaged Weight
			Basic Model	Trim Color	
 HRDPT	Telephone Caddy • Plastic construction • Suspends from Tool Rail	2 x 8 1/2 x 9 1/2"	PPTC	<input type="checkbox"/> <input type="checkbox"/>	0.8#
 HRDPT	Accessory Tray • Injection-molded plastic • Stores stamps, tape dispenser, post-it pads and paper clips • Suspends from Tool Rail	2 x 9 1/2 x 10"	PPAT	<input type="checkbox"/> <input type="checkbox"/>	6.0#
 HRDPT	Pencil Cup • Injection-molded plastic • Suspends from Tool Rail	4 x 4 x 3 1/2"	PPPC	<input type="checkbox"/> <input type="checkbox"/>	0.3#

A

B

HOW TO ORDER

Indicate the following information on order form:

- Quantity of each item.
- Model number, including options. See "How To Build a Model Number".
- Any special service required.

Note: • The indicates that a choice is required.

- The absence of the indicates that no choice is required.
- Alpha-numeric characters in place of indicate that no other alternatives are available.

HOW TO BUILD A MODEL NUMBER

A Select basic model.

B Select trim color.
Refer to the **Product Color Options** page in this catalog.

HOW TO ORDER

Indicate the following information on order form:

1. Quantity of each item.
2. Model number, including options. See "How To Build a Model Number".
3. Any special service required.

Note:

- The indicates that a choice is required.
- The absence of the indicates that no choice is required.
- Alpha-numeric characters in place of indicate that no other alternatives are available.

120° Intersections

2-Way

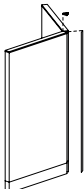
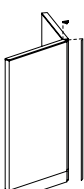
	MODEL	H	MODEL NUMBER				Approx. Packaged Weight
			Basic Model	Trim Color	Upholstery Color	Assembly	
 PTN - Pass Through	120° 2-Way, Both Panels Same Height <ul style="list-style-type: none"> • Upholstered: trim colored • 120° 2-way top cap • Light block • One piece of vertical trim extending to floor • Two half posts • Connecting hardware • SX Starlight Silver finish is only offered on flat aluminum trim 	30"	P1202W30			<input type="checkbox"/>	7.0#
		36"	P1202W36	<input type="checkbox"/>		<input type="checkbox"/>	9.0#
		42"	P1202W42	<input type="checkbox"/>		<input type="checkbox"/>	10.0#
		48"	P1202W48	<input type="checkbox"/>		<input type="checkbox"/>	12.0#
		54"	P1202W54	<input type="checkbox"/>		<input type="checkbox"/>	13.0#
		66"	P1202W66	<input type="checkbox"/>		<input type="checkbox"/>	16.0#
		72"	P1202W72	<input type="checkbox"/>		<input type="checkbox"/>	17.0#
		84"	P1202W84	<input type="checkbox"/>		<input type="checkbox"/>	20.0#
 PTNF - Pass Through	120° 2-Way, Both Panels Same Height <ul style="list-style-type: none"> • Upholstered: trim colored • 120° 2-way top cap • Light block • One piece of vertical trim extending to floor • Two half posts • Connecting hardware • SX Starlight Silver finish is only offered on flat aluminum trim 	30"	P120F2W30	<input type="checkbox"/>	<input type="checkbox"/>	<input type="checkbox"/>	7.0#
		36"	P120F2W36	<input type="checkbox"/>	<input type="checkbox"/>	<input type="checkbox"/>	9.0#
		42"	P120F2W42	<input type="checkbox"/>	<input type="checkbox"/>	<input type="checkbox"/>	10.0#
		48"	P120F2W48	<input type="checkbox"/>	<input type="checkbox"/>	<input type="checkbox"/>	12.0#
		54"	P120F2W54	<input type="checkbox"/>	<input type="checkbox"/>	<input type="checkbox"/>	13.0#
		66"	P120F2W66	<input type="checkbox"/>	<input type="checkbox"/>	<input type="checkbox"/>	16.0#
		72"	P120F2W72	<input type="checkbox"/>	<input type="checkbox"/>	<input type="checkbox"/>	17.0#
		84"	P120F2W84	<input type="checkbox"/>	<input type="checkbox"/>	<input type="checkbox"/>	20.0#
			A	B	C	D	

HOW TO ORDER

Indicate the following information on order form:

1. Quantity of each item.
2. Model number, including options. See "How To Build a Model Number".
3. Any special service required.

Note: • The indicates that a choice is required.

- The absence of the indicates that no choice is required.
- Alpha-numeric characters in place of indicate that no other alternatives are available.

HOW TO BUILD A MODEL NUMBER

- A** Select basic model.
- B** Select trim color.
Refer to the **Product Color Options** page in this catalog.
SX Starlight Silver finish is only offered on flat aluminum trim.
- C** Select upholstery color.
- D** Select assembly.
- | | |
|----------|-------------------|
| F | - Fully Assembled |
| U | - Unassembled |

120° Intersections

2-Way

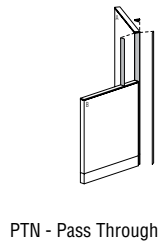
**MODEL****A x B****MODEL NUMBER**Basic
ModelTrim
ColorApprox.
Packaged
Weight**120° 2-Way, Two Different Heights**

- Upholstered: trim colored
- 120° 1-way top cap
- Light block
- One piece of vertical trim extends to floor
- One piece of height change trim
- One half post A
- One half post B
- Connecting hardware
- SX Starlight Silver finish is only offered on flat aluminum trim

MODEL	A x B	Basic Model	Trim Color	Approx. Packaged Weight
	36" 30"	P120V2W3036	<input type="checkbox"/>	9.0#
	42" 30"	P120V2W3042	<input type="checkbox"/>	11.0#
	48" 30"	P120V2W3048	<input type="checkbox"/>	12.0#
	54" 30"	P120V2W3054	<input type="checkbox"/>	13.0#
	66" 30"	P120V2W3066	<input type="checkbox"/>	15.0#
	72" 30"	P120V2W3072	<input type="checkbox"/>	16.0#
	84" 30"	P120V2W3084	<input type="checkbox"/>	20.0#
	42" 36"	P120V2W3642	<input type="checkbox"/>	9.0#
	48" 36"	P120V2W3648	<input type="checkbox"/>	11.0#
	54" 36"	P120V2W3654	<input type="checkbox"/>	12.0#
	66" 36"	P120V2W3666	<input type="checkbox"/>	14.0#
	72" 36"	P120V2W3672	<input type="checkbox"/>	15.0#
	84" 36"	P120V2W3684	<input type="checkbox"/>	20.0#
	48" 42"	P120V2W4248	<input type="checkbox"/>	9.0#
	54" 42"	P120V2W4254	<input type="checkbox"/>	11.0#
	66" 42"	P120V2W4266	<input type="checkbox"/>	13.0#
	72" 42"	P120V2W4272	<input type="checkbox"/>	14.0#
	84" 42"	P120V2W4284	<input type="checkbox"/>	18.0#
	54" 48"	P120V2W4854	<input type="checkbox"/>	9.0#
	66" 48"	P120V2W4866	<input type="checkbox"/>	14.0#
	72" 48"	P120V2W4872	<input type="checkbox"/>	15.0#
	84" 48"	P120V2W4884	<input type="checkbox"/>	18.0#
	66" 54"	P120V2W5466	<input type="checkbox"/>	12.0#
	72" 54"	P120V2W5472	<input type="checkbox"/>	14.0#
	84" 54"	P120V2W5484	<input type="checkbox"/>	18.0#
	72" 66"	P120V2W6672	<input type="checkbox"/>	9.0#
	84" 66"	P120V2W6684	<input type="checkbox"/>	12.0#
	84" 72"	P120V2W7284	<input type="checkbox"/>	11.0#

A**B****HOW TO ORDER**

Indicate the following information on order form:

1. Quantity of each item.
2. Model number, including options. See "How To Build a Model Number".
3. Any special service required.

Note: • The indicates that a choice is required.

- The absence of the indicates that no choice is required.
- Alpha-numeric characters in place of indicate that no other alternatives are available.

HOW TO BUILD A MODEL NUMBER

A Select basic model.

B Select trim color.

Refer to the **Product Color Options** page in this catalog.
SX Starlight Silver finish is only offered on flat aluminum trim.

120° Intersections

2-Way

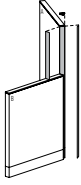

PTNF - Pass Through

MODEL	A x B	MODEL NUMBER			Approx. Packaged Weight
		Basic Model	Trim Color	Upholstery Color	
120° 2-Way, Two Different Heights • Unupholstered: trim colored • 120° 1-way top cap • Light block • One piece of vertical trim extends to floor • One piece of height change trim • One half post A • One half post B • Connecting hardware • SX Starlight Silver finish is only offered on flat aluminum trim	36" 30"	P120VF2W3036	<input type="checkbox"/>	<input type="checkbox"/>	9.0#
	42" 30"	P120VF2W3042	<input type="checkbox"/>	<input type="checkbox"/>	11.0#
	48" 30"	P120VF2W3048	<input type="checkbox"/>	<input type="checkbox"/>	12.0#
	54" 30"	P120VF2W3054	<input type="checkbox"/>	<input type="checkbox"/>	13.0#
	66" 30"	P120VF2W3066	<input type="checkbox"/>	<input type="checkbox"/>	15.0#
	72" 30"	P120VF2W3072	<input type="checkbox"/>	<input type="checkbox"/>	16.0#
	84" 30"	P120VF2W3084	<input type="checkbox"/>	<input type="checkbox"/>	20.0#
	42" 36"	P120VF2W3642	<input type="checkbox"/>	<input type="checkbox"/>	9.0#
	48" 36"	P120VF2W3648	<input type="checkbox"/>	<input type="checkbox"/>	11.0#
	54" 36"	P120VF2W3654	<input type="checkbox"/>	<input type="checkbox"/>	13.0#
	66" 36"	P120VF2W3666	<input type="checkbox"/>	<input type="checkbox"/>	15.0#
	72" 36"	P120VF2W3672	<input type="checkbox"/>	<input type="checkbox"/>	16.0#
	84" 36"	P120VF2W3684	<input type="checkbox"/>	<input type="checkbox"/>	20.0#
	48" 42"	P120VF2W4248	<input type="checkbox"/>	<input type="checkbox"/>	9.0#
	54" 42"	P120VF2W4254	<input type="checkbox"/>	<input type="checkbox"/>	11.0#
	66" 42"	P120VF2W4266	<input type="checkbox"/>	<input type="checkbox"/>	14.0#
	72" 42"	P120VF2W4272	<input type="checkbox"/>	<input type="checkbox"/>	15.0#
	84" 42"	P120VF2W4284	<input type="checkbox"/>	<input type="checkbox"/>	18.0#
	54" 48"	P120VF2W4854	<input type="checkbox"/>	<input type="checkbox"/>	9.0#
	66" 48"	P120VF2W4866	<input type="checkbox"/>	<input type="checkbox"/>	12.0#
	72" 48"	P120VF2W4872	<input type="checkbox"/>	<input type="checkbox"/>	14.0#
	84" 48"	P120VF2W4884	<input type="checkbox"/>	<input type="checkbox"/>	20.0#
	66" 54"	P120VF2W5466	<input type="checkbox"/>	<input type="checkbox"/>	11.0#
	72" 54"	P120VF2W5472	<input type="checkbox"/>	<input type="checkbox"/>	12.0#
	84" 54"	P120VF2W5484	<input type="checkbox"/>	<input type="checkbox"/>	18.0#
	72" 66"	P120VF2W6672	<input type="checkbox"/>	<input type="checkbox"/>	9.0#
	84" 66"	P120VF2W6684	<input type="checkbox"/>	<input type="checkbox"/>	16.0#
	84" 72"	P120VF2W7284	<input type="checkbox"/>	<input type="checkbox"/>	11.0#

A

B

C

HOW TO ORDER

Indicate the following information on order form:

- Quantity of each item.
- Model number, including options. See "How To Build a Model Number".
- Any special service required.

Note: • The indicates that a choice is required.

- The absence of the indicates that no choice is required.
- Alpha-numeric characters in place of indicate that no other alternatives are available.

HOW TO BUILD A MODEL NUMBER

- A** Select basic model.
- B** Select trim color.
Refer to the **Product Color Options** page in this catalog.
SX Starlight Silver finish is only offered on flat aluminum trim.
- C** Select upholstery color.

120° Intersections

3-Way

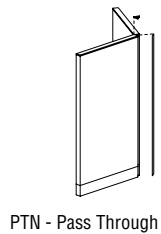

MODEL

- 120° 3-Way, All Panels Same Height**
- Upholstered: trim colored
 - 120° 3-way top cap
 - Light block
 - Three half posts
 - Connecting hardware
 - SX Starlight Silver finish is only offered on flat aluminum trim

H	MODEL NUMBER			Approx. Packaged Weight
	Basic Model	Trim Color	Assembly	
30"	P1203W30	<input type="checkbox"/> <input type="checkbox"/>	<input type="checkbox"/>	9.0#
36"	P1203W36	<input type="checkbox"/> <input type="checkbox"/>	<input type="checkbox"/>	11.0#
42"	P1203W42	<input type="checkbox"/> <input type="checkbox"/>	<input type="checkbox"/>	12.0#
48"	P1203W48	<input type="checkbox"/> <input type="checkbox"/>	<input type="checkbox"/>	13.0#
54"	P1203W54	<input type="checkbox"/> <input type="checkbox"/>	<input type="checkbox"/>	15.0#
66"	P1203W66	<input type="checkbox"/> <input type="checkbox"/>	<input type="checkbox"/>	18.0#
72"	P1203W72	<input type="checkbox"/> <input type="checkbox"/>	<input type="checkbox"/>	19.0#
84"	P1203W84	<input type="checkbox"/> <input type="checkbox"/>	<input type="checkbox"/>	22.0#

A

B

C

HOW TO ORDER

Indicate the following information on order form:

1. Quantity of each item.
2. Model number, including options. See "How To Build a Model Number".
3. Any special service required.

Note: • The indicates that a choice is required.

- The absence of the indicates that no choice is required.
- Alpha-numeric characters in place of indicate that no other alternatives are available.

HOW TO BUILD A MODEL NUMBER

A Select basic model.

B Select trim color.
Refer to the **Product Color Options** page in this catalog.
SX Starlight Silver finish is only offered on flat aluminum trim.

C Select assembly.

F - Fully Assembled
U - Unassembled

120° Intersections

3-Way

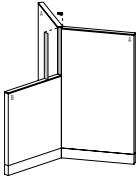
	MODEL	A x B	MODEL NUMBER		Approx. Packaged Weight
			Basic Model	Trim Color	
 <p>PTN - Pass Through</p>	120° 3-Way, Two Different Heights	36" 30"	P120V1203036	<input type="checkbox"/>	9.0#
	<ul style="list-style-type: none"> • Unupholstered: trim colored • 2-way top cap • Light block • One piece of height change trim • Two half posts A • One half post B • Connecting hardware • SX Starlight Silver finish is only offered on flat aluminum trim 	42" 30"	P120V1203042	<input type="checkbox"/>	11.0#
		48" 30"	P120V1203048	<input type="checkbox"/>	12.0#
		54" 30"	P120V1203054	<input type="checkbox"/>	13.0#
		66" 30"	P120V1203066	<input type="checkbox"/>	16.0#
		72" 30"	P120V1203072	<input type="checkbox"/>	17.0#
		84" 30"	P120V1203084	<input type="checkbox"/>	20.0#
		42" 36"	P120V1203642	<input type="checkbox"/>	9.0#
		48" 36"	P120V1203648	<input type="checkbox"/>	11.0#
		54" 36"	P120V1203654	<input type="checkbox"/>	12.0#
		66" 36"	P120V1203666	<input type="checkbox"/>	15.0#
		72" 36"	P120V1203672	<input type="checkbox"/>	16.0#
		84" 36"	P120V1203684	<input type="checkbox"/>	20.0#
		48" 42"	P120V1204248	<input type="checkbox"/>	9.0#
		54" 42"	P120V1204254	<input type="checkbox"/>	11.0#
		66" 42"	P120V1204266	<input type="checkbox"/>	13.0#
		72" 42"	P120V1204272	<input type="checkbox"/>	15.0#
		84" 42"	P120V1204284	<input type="checkbox"/>	20.0#
		54" 48"	P120V1204854	<input type="checkbox"/>	9.0#
		66" 48"	P120V1204866	<input type="checkbox"/>	12.0#
		72" 48"	P120V1204872	<input type="checkbox"/>	15.0#
		84" 48"	P120V1204884	<input type="checkbox"/>	20.0#
		66" 54"	P120V1205466	<input type="checkbox"/>	11.0#
		72" 54"	P120V1205472	<input type="checkbox"/>	15.0#
		84" 54"	P120V1205484	<input type="checkbox"/>	20.0#
		72" 66"	P120V1206672	<input type="checkbox"/>	9.0#
		84" 66"	P120V1206684	<input type="checkbox"/>	12.0#
		84" 72"	P120V1207284	<input type="checkbox"/>	11.0#

A

B

HOW TO ORDER

Indicate the following information on order form:

1. Quantity of each item.
2. Model number, including options. See "How To Build a Model Number".
3. Any special service required.

Note: • The indicates that a choice is required.

- The absence of the indicates that no choice is required.
- Alpha-numeric characters in place of indicate that no other alternatives are available.

HOW TO BUILD A MODEL NUMBER

A Select basic model.

B Select trim color.

Refer to the **Product Color Options** page in this catalog.
SX Starlight Silver finish is only offered on flat aluminum trim.

120° Intersections

3-Way

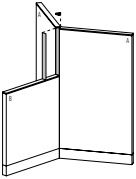
	MODEL	A x B	MODEL NUMBER			Approx. Packaged Weight
			Basic Model	Trim Color	Upholstery Color	
 <p>PTNF - Pass Through</p>	120° 3-Way, Two Different Heights	36" 30"	P120VF1203036	<input type="checkbox"/>	<input type="checkbox"/> <input type="checkbox"/> <input type="checkbox"/> <input type="checkbox"/>	9.0#
	• Upholstered	42" 30"	P120VF1203042	<input type="checkbox"/>	<input type="checkbox"/> <input type="checkbox"/> <input type="checkbox"/> <input type="checkbox"/>	11.0#
	• 120° 2-way top cap	48" 30"	P120VF1203048	<input type="checkbox"/>	<input type="checkbox"/> <input type="checkbox"/> <input type="checkbox"/> <input type="checkbox"/>	12.0#
	• Light block	54" 30"	P120VF1203054	<input type="checkbox"/>	<input type="checkbox"/> <input type="checkbox"/> <input type="checkbox"/> <input type="checkbox"/>	13.0#
	• One piece of height change trim	66" 30"	P120VF1203066	<input type="checkbox"/>	<input type="checkbox"/> <input type="checkbox"/> <input type="checkbox"/> <input type="checkbox"/>	15.0#
	• Two half posts A	72" 30"	P120VF1203072	<input type="checkbox"/>	<input type="checkbox"/> <input type="checkbox"/> <input type="checkbox"/> <input type="checkbox"/>	16.0#
	• One half post B	84" 30"	P120VF1203084	<input type="checkbox"/>	<input type="checkbox"/> <input type="checkbox"/> <input type="checkbox"/> <input type="checkbox"/>	20.0#
	• Connecting hardware	42" 36"	P120VF1203642	<input type="checkbox"/>	<input type="checkbox"/> <input type="checkbox"/> <input type="checkbox"/> <input type="checkbox"/>	9.0#
	• SX Starlight Silver finish is only offered on flat aluminum trim	48" 36"	P120VF1203648	<input type="checkbox"/>	<input type="checkbox"/> <input type="checkbox"/> <input type="checkbox"/> <input type="checkbox"/>	10.0#
		54" 36"	P120VF1203654	<input type="checkbox"/>	<input type="checkbox"/> <input type="checkbox"/> <input type="checkbox"/> <input type="checkbox"/>	11.0#
		66" 36"	P120VF1203666	<input type="checkbox"/>	<input type="checkbox"/> <input type="checkbox"/> <input type="checkbox"/> <input type="checkbox"/>	13.0#
		72" 36"	P120VF1203672	<input type="checkbox"/>	<input type="checkbox"/> <input type="checkbox"/> <input type="checkbox"/> <input type="checkbox"/>	14.0#
		84" 36"	P120VF1203684	<input type="checkbox"/>	<input type="checkbox"/> <input type="checkbox"/> <input type="checkbox"/> <input type="checkbox"/>	18.0#
		48" 42"	P120VF1204248	<input type="checkbox"/>	<input type="checkbox"/> <input type="checkbox"/> <input type="checkbox"/> <input type="checkbox"/>	9.0#
		54" 42"	P120VF1204254	<input type="checkbox"/>	<input type="checkbox"/> <input type="checkbox"/> <input type="checkbox"/> <input type="checkbox"/>	11.0#
		66" 42"	P120VF1204266	<input type="checkbox"/>	<input type="checkbox"/> <input type="checkbox"/> <input type="checkbox"/> <input type="checkbox"/>	13.0#
		72" 42"	P120VF1204272	<input type="checkbox"/>	<input type="checkbox"/> <input type="checkbox"/> <input type="checkbox"/> <input type="checkbox"/>	14.0#
		84" 42"	P120VF1204284	<input type="checkbox"/>	<input type="checkbox"/> <input type="checkbox"/> <input type="checkbox"/> <input type="checkbox"/>	18.0#
		54" 48"	P120VF1204854	<input type="checkbox"/>	<input type="checkbox"/> <input type="checkbox"/> <input type="checkbox"/> <input type="checkbox"/>	9.0#
		66" 48"	P120VF1204866	<input type="checkbox"/>	<input type="checkbox"/> <input type="checkbox"/> <input type="checkbox"/> <input type="checkbox"/>	12.0#
		72" 48"	P120VF1204872	<input type="checkbox"/>	<input type="checkbox"/> <input type="checkbox"/> <input type="checkbox"/> <input type="checkbox"/>	14.0#
		84" 48"	P120VF1204884	<input type="checkbox"/>	<input type="checkbox"/> <input type="checkbox"/> <input type="checkbox"/> <input type="checkbox"/>	18.0#
		66" 54"	P120VF1205466	<input type="checkbox"/>	<input type="checkbox"/> <input type="checkbox"/> <input type="checkbox"/> <input type="checkbox"/>	11.0#
		72" 54"	P120VF1205472	<input type="checkbox"/>	<input type="checkbox"/> <input type="checkbox"/> <input type="checkbox"/> <input type="checkbox"/>	12.0#
		84" 54"	P120VF1205484	<input type="checkbox"/>	<input type="checkbox"/> <input type="checkbox"/> <input type="checkbox"/> <input type="checkbox"/>	16.0#
		72" 66"	P120VF1206672	<input type="checkbox"/>	<input type="checkbox"/> <input type="checkbox"/> <input type="checkbox"/> <input type="checkbox"/>	9.0#
		84" 66"	P120VF1206684	<input type="checkbox"/>	<input type="checkbox"/> <input type="checkbox"/> <input type="checkbox"/> <input type="checkbox"/>	11.0#
		84" 72"	P120VF1207284	<input type="checkbox"/>	<input type="checkbox"/> <input type="checkbox"/> <input type="checkbox"/> <input type="checkbox"/>	11.0#

A

B

C

HOW TO ORDER

Indicate the following information on order form:

- Quantity of each item.
- Model number, including options. See "How To Build a Model Number".
- Any special service required.

Note: • The indicates that a choice is required.

- The absence of the indicates that no choice is required.
- Alpha-numeric characters in place of indicate that no other alternatives are available.

HOW TO BUILD A MODEL NUMBER

A Select basic model.

B Select trim color.
Refer to the **Product Color Options** page in this catalog.
SX Starlight Silver finish is only offered on flat aluminum trim.

C Select upholstery color.

120° Intersections

3-Way

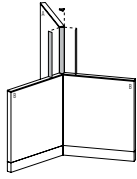

PTN - Pass Through

MODEL	A x B	MODEL NUMBER		Approx. Packaged Weight
		Basic Model	Trim Color	
120° 3-Way, Two Different Heights • Unupholstered: trim colored • 120° 1-way top cap • Light block • Two pieces of height change trim • One half post A • Two half posts B • Connecting hardware • SX Starlight Silver finish is only offered on flat aluminum trim	36" 30"	P120V1W3036	<input type="checkbox"/>	9.0#
	42" 30"	P120V1W3042	<input type="checkbox"/>	10.0#
	48" 30"	P120V1W3048	<input type="checkbox"/>	11.0#
	54" 30"	P120V1W3054	<input type="checkbox"/>	12.0#
	66" 30"	P120V1W3066	<input type="checkbox"/>	15.0#
	72" 30"	P120V1W3072	<input type="checkbox"/>	16.0#
	84" 30"	P120V1W3084	<input type="checkbox"/>	20.0#
	42" 36"	P120V1W3642	<input type="checkbox"/>	9.0#
	48" 36"	P120V1W3648	<input type="checkbox"/>	11.0#
	54" 36"	P120V1W3654	<input type="checkbox"/>	12.0#
	66" 36"	P120V1W3666	<input type="checkbox"/>	15.0#
	72" 36"	P120V1W3672	<input type="checkbox"/>	16.0#
	84" 36"	P120V1W3684	<input type="checkbox"/>	20.0#
	48" 42"	P120V1W4248	<input type="checkbox"/>	9.0#
	54" 42"	P120V1W4254	<input type="checkbox"/>	11.0#
	66" 42"	P120V1W4266	<input type="checkbox"/>	14.0#
	72" 42"	P120V1W4272	<input type="checkbox"/>	16.0#
	84" 42"	P120V1W4284	<input type="checkbox"/>	20.0#
	54" 48"	P120V1W4854	<input type="checkbox"/>	9.0#
	66" 48"	P120V1W4866	<input type="checkbox"/>	12.0#
	72" 48"	P120V1W4872	<input type="checkbox"/>	14.0#
	84" 48"	P120V1W4884	<input type="checkbox"/>	18.0#
	66" 54"	P120V1W5466	<input type="checkbox"/>	11.0#
	72" 54"	P120V1W5472	<input type="checkbox"/>	12.0#
	84" 54"	P120V1W5484	<input type="checkbox"/>	16.0#
	72" 66"	P120V1W6672	<input type="checkbox"/>	9.0#
	84" 66"	P120V1W6684	<input type="checkbox"/>	12.0#
	84" 72"	P120V1W7284	<input type="checkbox"/>	11.0#

A

B

HOW TO ORDER

Indicate the following information on order form:

- Quantity of each item.
- Model number, including options. See "How To Build a Model Number".
- Any special service required.

Note: • The indicates that a choice is required.

- The absence of the indicates that no choice is required.
- Alpha-numeric characters in place of indicate that no other alternatives are available.

HOW TO BUILD A MODEL NUMBER

A Select basic model.

B Select trim color.

Refer to the **Product Color Options** page in this catalog.
 SX Starlight Silver finish is only offered on flat aluminum trim.

120° Intersections

3-Way

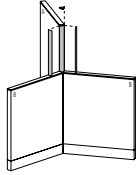

PTNF - Pass Through

- MODEL**
- 120° 3-Way, Two Different Heights**
- Upholstered
 - 120° 1-way top cap
 - Light block
 - Two pieces of height change trim
 - One half post A
 - Two half posts B
 - Connecting hardware
 - SX Starlight Silver finish is only offered on flat aluminum trim

MODEL	A x B	MODEL NUMBER			Approx. Packaged Weight
		Basic Model	Trim Color	Upholstery Color	
	36" 30"	P120VF1W3036	<input type="checkbox"/>	<input type="checkbox"/>	9.0#
	42" 30"	P120VF1W3042	<input type="checkbox"/>	<input type="checkbox"/>	12.0#
	48" 30"	P120VF1W3048	<input type="checkbox"/>	<input type="checkbox"/>	14.0#
	54" 30"	P120VF1W3054	<input type="checkbox"/>	<input type="checkbox"/>	16.0#
	66" 30"	P120VF1W3066	<input type="checkbox"/>	<input type="checkbox"/>	20.0#
	72" 30"	P120VF1W3072	<input type="checkbox"/>	<input type="checkbox"/>	22.0#
	84" 30"	P120VF1W3084	<input type="checkbox"/>	<input type="checkbox"/>	26.0#
	42" 36"	P120VF1W3642	<input type="checkbox"/>	<input type="checkbox"/>	9.0#
	48" 36"	P120VF1W3648	<input type="checkbox"/>	<input type="checkbox"/>	12.0#
	54" 36"	P120VF1W3654	<input type="checkbox"/>	<input type="checkbox"/>	14.0#
	66" 36"	P120VF1W3666	<input type="checkbox"/>	<input type="checkbox"/>	18.0#
	72" 36"	P120VF1W3672	<input type="checkbox"/>	<input type="checkbox"/>	20.0#
	84" 36"	P120VF1W3684	<input type="checkbox"/>	<input type="checkbox"/>	24.0#
	48" 42"	P120VF1W4248	<input type="checkbox"/>	<input type="checkbox"/>	9.0#
	54" 42"	P120VF1W4254	<input type="checkbox"/>	<input type="checkbox"/>	12.0#
	66" 42"	P120VF1W4266	<input type="checkbox"/>	<input type="checkbox"/>	16.0#
	72" 42"	P120VF1W4272	<input type="checkbox"/>	<input type="checkbox"/>	18.0#
	84" 42"	P120VF1W4284	<input type="checkbox"/>	<input type="checkbox"/>	22.0#
	54" 48"	P120VF1W4854	<input type="checkbox"/>	<input type="checkbox"/>	9.0#
	66" 48"	P120VF1W4866	<input type="checkbox"/>	<input type="checkbox"/>	14.0#
	72" 48"	P120VF1W4872	<input type="checkbox"/>	<input type="checkbox"/>	16.0#
	84" 48"	P120VF1W4884	<input type="checkbox"/>	<input type="checkbox"/>	20.0#
	66" 54"	P120VF1W5466	<input type="checkbox"/>	<input type="checkbox"/>	12.0#
	72" 54"	P120VF1W5472	<input type="checkbox"/>	<input type="checkbox"/>	14.0#
	84" 54"	P120VF1W5484	<input type="checkbox"/>	<input type="checkbox"/>	18.0#
	72" 66"	P120VF1W6672	<input type="checkbox"/>	<input type="checkbox"/>	9.0#
	84" 66"	P120VF1W6684	<input type="checkbox"/>	<input type="checkbox"/>	14.0#
	84" 72"	P120VF1W7284	<input type="checkbox"/>	<input type="checkbox"/>	12.0#

A **B** **C**

HOW TO ORDER

Indicate the following information on order form:

1. Quantity of each item.
2. Model number, including options. See "How To Build a Model Number".
3. Any special service required.



- Note:
- The indicates that a choice is required.
 - The absence of the indicates that no choice is required.
 - Alpha-numeric characters in place of indicate that no other alternatives are available.

HOW TO BUILD A MODEL NUMBER

- A** Select basic model.
- B** Select trim color.
Refer to the **Product Color Options** page in this catalog.
SX Starlight Silver finish is only offered on flat aluminum trim.
- C** Select upholstery color.

120° Intersections

2-Way and 3-Way Stackable

	MODEL	H	MODEL NUMBER			Approx. Packaged Weight
			Basic Model	Trim Color	Upholstery Color	
	2-Way Stackable • Upholstered: trim color • One piece of stackable vertical trim • Two stackable half-posts • One 120° corner connector block • Use top cap from existing lower panel • SX Starlight Silver finish is only offered on flat aluminum trim	12"	PS1202W12	<input type="checkbox"/>		5.0#
		18"	PS1202W18	<input type="checkbox"/>		6.0#
		24"	PS1202W24	<input type="checkbox"/>		7.0#
PST						
	2-Way Stackable • Upholstered • One piece of stackable vertical trim • Two stackable half-posts • One 120° corner connector block • Use top cap from existing lower panel • SX Starlight Silver finish is only offered on flat aluminum trim	12"	PS120F2W12	<input type="checkbox"/>	<input type="checkbox"/> <input type="checkbox"/> <input type="checkbox"/> <input type="checkbox"/>	5.0#
		18"	PS120F2W18	<input type="checkbox"/>	<input type="checkbox"/> <input type="checkbox"/> <input type="checkbox"/> <input type="checkbox"/>	6.0#
		24"	PS120F2W24	<input type="checkbox"/>	<input type="checkbox"/> <input type="checkbox"/> <input type="checkbox"/> <input type="checkbox"/>	7.0#
PSTF						
	3-Way Stackable • Upholstered • Three stackable half-posts • One 120° corner connector block • Use top cap from existing lower panel • SX Starlight Silver finish is only offered on flat aluminum trim	12"	PS1203W12	<input type="checkbox"/>		7.0#
		18"	PS1203W18	<input type="checkbox"/>		8.0#
		24"	PS1203W24	<input type="checkbox"/>		9.0#
PST						

A **B** **C**

HOW TO ORDER

Indicate the following information on order form:

- Quantity of each item.
- Model number, including options. See "How To Build a Model Number".
- Any special service required.

Note: • The indicates that a choice is required.

- The absence of the indicates that no choice is required.
- Alpha-numeric characters in place of indicate that no other alternatives are available.

HOW TO BUILD A MODEL NUMBER

- A** Select basic model.
- B** Select trim color.
Refer to the **Product Color Options** page in this catalog.
SX Starlight Silver finish is only offered on flat aluminum trim.
- C** Select upholstery color.

120° Worksurfaces

Corner Worksurfaces

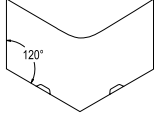
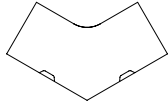
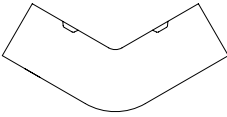
MODEL	MODEL NUMBER								Approx. Packaged Weight
	Basic Model	Edge Style	Surface Finish	Trim Color	Wood Edge Color	Veneer Color	Edge Color	Grommet Color	
 <p>Inside Corner Worksurface with 120° Ends</p> <ul style="list-style-type: none"> Includes mounting hardware Left hand cantilever is provided for rear corner Includes two 2-1/2" x 6" grommets 	PW120243624	<input type="checkbox"/>	<input type="checkbox"/>	<input type="checkbox"/>	<input type="checkbox"/>	<input type="checkbox"/>	<input type="checkbox"/>	<input type="checkbox"/>	44.0#
	PW120244224	<input type="checkbox"/>	<input type="checkbox"/>	<input type="checkbox"/>	<input type="checkbox"/>	<input type="checkbox"/>	<input type="checkbox"/>	<input type="checkbox"/>	53.0#
	PW120244824	<input type="checkbox"/>	<input type="checkbox"/>	<input type="checkbox"/>	<input type="checkbox"/>	<input type="checkbox"/>	<input type="checkbox"/>	<input type="checkbox"/>	62.0#
	PW120303630	<input type="checkbox"/>	<input type="checkbox"/>	<input type="checkbox"/>	<input type="checkbox"/>	<input type="checkbox"/>	<input type="checkbox"/>	<input type="checkbox"/>	65.0#
	PW120304230	<input type="checkbox"/>	<input type="checkbox"/>	<input type="checkbox"/>	<input type="checkbox"/>	<input type="checkbox"/>	<input type="checkbox"/>	<input type="checkbox"/>	67.0#
	PW120304830	<input type="checkbox"/>	<input type="checkbox"/>	<input type="checkbox"/>	<input type="checkbox"/>	<input type="checkbox"/>	<input type="checkbox"/>	<input type="checkbox"/>	76.0#
 <p>Inside Corner Worksurface with 90° Ends</p>	PWIC120243624	<input type="checkbox"/>	<input type="checkbox"/>	<input type="checkbox"/>	<input type="checkbox"/>	<input type="checkbox"/>	<input type="checkbox"/>	<input type="checkbox"/>	44.0#
	PWIC120244224	<input type="checkbox"/>	<input type="checkbox"/>	<input type="checkbox"/>	<input type="checkbox"/>	<input type="checkbox"/>	<input type="checkbox"/>	<input type="checkbox"/>	53.0#
	PWIC120244824	<input type="checkbox"/>	<input type="checkbox"/>	<input type="checkbox"/>	<input type="checkbox"/>	<input type="checkbox"/>	<input type="checkbox"/>	<input type="checkbox"/>	62.0#
	PWIC120303630	<input type="checkbox"/>	<input type="checkbox"/>	<input type="checkbox"/>	<input type="checkbox"/>	<input type="checkbox"/>	<input type="checkbox"/>	<input type="checkbox"/>	65.0#
	PWIC120304230	<input type="checkbox"/>	<input type="checkbox"/>	<input type="checkbox"/>	<input type="checkbox"/>	<input type="checkbox"/>	<input type="checkbox"/>	<input type="checkbox"/>	67.0#
PWIC120304830	<input type="checkbox"/>	<input type="checkbox"/>	<input type="checkbox"/>	<input type="checkbox"/>	<input type="checkbox"/>	<input type="checkbox"/>	<input type="checkbox"/>	70.0#	
 <p>Outside Corner Worksurface with 90° Ends</p>	PWOC120243624	<input type="checkbox"/>	<input type="checkbox"/>	<input type="checkbox"/>	<input type="checkbox"/>	<input type="checkbox"/>	<input type="checkbox"/>	<input type="checkbox"/>	44.0#
	PWOC120244224	<input type="checkbox"/>	<input type="checkbox"/>	<input type="checkbox"/>	<input type="checkbox"/>	<input type="checkbox"/>	<input type="checkbox"/>	<input type="checkbox"/>	53.0#
	PWOC120244824	<input type="checkbox"/>	<input type="checkbox"/>	<input type="checkbox"/>	<input type="checkbox"/>	<input type="checkbox"/>	<input type="checkbox"/>	<input type="checkbox"/>	62.0#
	PWOC120303630	<input type="checkbox"/>	<input type="checkbox"/>	<input type="checkbox"/>	<input type="checkbox"/>	<input type="checkbox"/>	<input type="checkbox"/>	<input type="checkbox"/>	65.0#
	PWOC120304230	<input type="checkbox"/>	<input type="checkbox"/>	<input type="checkbox"/>	<input type="checkbox"/>	<input type="checkbox"/>	<input type="checkbox"/>	<input type="checkbox"/>	67.0#
	PWOC120304830	<input type="checkbox"/>	<input type="checkbox"/>	<input type="checkbox"/>	<input type="checkbox"/>	<input type="checkbox"/>	<input type="checkbox"/>	<input type="checkbox"/>	76.0#

A B C D E F G H

HOW TO ORDER

Indicate the following information on order form:

- Quantity of each item.
- Model number, including options. See "How To Build a Model Number".
- Any special service required.

Note: • The indicates that a choice is required.
 • The absence of the indicates that no choice is required.
 • Alpha-numeric characters in place of indicate that no other alternatives are available.

HOW TO BUILD A MODEL NUMBER

- A** Select basic model.
- B** Select edge style.
 74P - 74P edge
- C** Select surface finish.
 Refer to the **Product Color Options** page in this catalog.
 Surface finish offerings are based on edge style selections.
- D** Select trim color.
 Refer to the **Product Color Options** page in this catalog.
- E** Select wood edge color.
 Refer to the **Product Color Options** page in this catalog.
- F** Select wood veneer color.
 Refer to the **Product Color Options** page in this catalog.
- G** Select edge color.
 Refer to the **Product Color Options** page in this catalog.
- H** Select grommet color.
 Refer to the **Product Color Options** page in this catalog.

Tech Preconfigured Intersection Conditions

90° 2-Way and End-of-Run

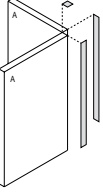
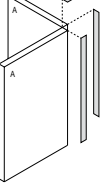
	MODEL	H	MODEL NUMBER			Approx. Packaged Weight
			Basic Model	Trim Color	Fabric Color	
 TECN	End-of-Run Condition	30"	TEP/30	<input type="checkbox"/>		5.0#
	• Upholstered: trim colored	36"	TEP/36	<input type="checkbox"/>		5.0#
	• End-of-run trim (Tech)	42"	TEP/42	<input type="checkbox"/>		7.0#
	• Top cap	48"	TEP/48	<input type="checkbox"/>		8.0#
	• One full post	54"	TEP/54	<input type="checkbox"/>		9.0#
	• End-of-run base tile hooks	60"	TEP/60	<input type="checkbox"/>		10.0#
	• SX Starlight Silver finish is only offered on flat aluminum trim	66"	TEP/66	<input type="checkbox"/>		11.0#
		72"	TEP/72	<input type="checkbox"/>		11.0#
		78"	TEP/78	<input type="checkbox"/>		12.0#
		84"	TEP/84	<input type="checkbox"/>		13.0#
 TECN	90° 2-Way "L" Corner, Both Panels Same Height	30"	TCP90/30	<input type="checkbox"/>		9.0#
	• Upholstered: trim colored	36"	TCP90/36	<input type="checkbox"/>		9.0#
	• 90° top cap	42"	TCP90/42	<input type="checkbox"/>		11.0#
	• Two pieces of universal trim (Tech)	48"	TCP90/48	<input type="checkbox"/>		12.0#
	• Two half-posts	54"	TCP90/54	<input type="checkbox"/>		13.0#
	• Two sets of half post base tile hooks	60"	TCP90/60	<input type="checkbox"/>		15.0#
	• Connecting hardware	66"	TCP90/66	<input type="checkbox"/>		16.0#
	• SX Starlight Silver finish is only offered on flat aluminum trim	72"	TCP90/72	<input type="checkbox"/>		16.0#
		78"	TCP90/78	<input type="checkbox"/>		16.0#
		84"	TCP90/84	<input type="checkbox"/>		16.0#
 TEF2	90° 2-Way "L" Corner, Both Panels Same Height	30"	TCPF90/30	<input type="checkbox"/>	<input type="checkbox"/> <input type="checkbox"/> <input type="checkbox"/> <input type="checkbox"/>	7.0#
	• Upholstered	36"	TCPF90/36	<input type="checkbox"/>	<input type="checkbox"/> <input type="checkbox"/> <input type="checkbox"/> <input type="checkbox"/>	7.0#
	• 90° top cap	42"	TCPF90/42	<input type="checkbox"/>	<input type="checkbox"/> <input type="checkbox"/> <input type="checkbox"/> <input type="checkbox"/>	10.0#
	• Two pieces of universal trim	48"	TCPF90/48	<input type="checkbox"/>	<input type="checkbox"/> <input type="checkbox"/> <input type="checkbox"/> <input type="checkbox"/>	11.0#
	• Two half-posts	54"	TCPF90/54	<input type="checkbox"/>	<input type="checkbox"/> <input type="checkbox"/> <input type="checkbox"/> <input type="checkbox"/>	13.0#
	• Two sets of half post base tile hooks	60"	TCPF90/60	<input type="checkbox"/>	<input type="checkbox"/> <input type="checkbox"/> <input type="checkbox"/> <input type="checkbox"/>	14.0#
	• Connecting hardware	66"	TCPF90/66	<input type="checkbox"/>	<input type="checkbox"/> <input type="checkbox"/> <input type="checkbox"/> <input type="checkbox"/>	16.0#
	• SX Starlight Silver finish is only offered on flat aluminum trim	72"	TCPF90/72	<input type="checkbox"/>	<input type="checkbox"/> <input type="checkbox"/> <input type="checkbox"/> <input type="checkbox"/>	16.0#
		78"	TCPF90/78	<input type="checkbox"/>	<input type="checkbox"/> <input type="checkbox"/> <input type="checkbox"/> <input type="checkbox"/>	16.0#
		84"	TCPF90/84	<input type="checkbox"/>	<input type="checkbox"/> <input type="checkbox"/> <input type="checkbox"/> <input type="checkbox"/>	16.0#

A **B** **C**

HOW TO ORDER

Indicate the following information on order form:

- Quantity of each item.
- Model number, including options. See "How To Build a Model Number".
- Any special service required.

Note: • The indicates that a choice is required.

- The absence of the indicates that no choice is required.
- Alpha-numeric characters in place of indicate that no other alternatives are available.

HOW TO BUILD A MODEL NUMBER

- A** Select basic model.
- B** Select trim color.
Refer to the **Product Color Options** page in this catalog.
SX Starlight Silver finish is only offered on flat aluminum trim.
- C** Select fabric color.

Tech Preconfigured Intersection Conditions

90° 2-Way

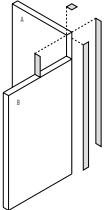
	MODEL	A	B	A-B	MODEL NUMBER		Approx. Packaged Weight
					Basic Model	Trim Color	
 <p>TECN</p>	90° 2-Way "L" Corner, Two Different Heights <ul style="list-style-type: none"> • Unupholstered • 1-way top cap • Two pieces of universal trim (Tech) • One piece of universal height change trim • One half-post (height A) • One half-post (height B) • Two sets of half post base tile hooks • Connecting hardware • SX Starlight Silver finish is only offered on flat aluminum trim 	30" 30" 6"	TCPV90/3036	<input type="checkbox"/>	9.0#		
		42" 30" 12"	TCPV90/3042	<input type="checkbox"/>	9.0#		
		48" 30" 18"	TCPV90/3048	<input type="checkbox"/>	9.0#		
		54" 30" 24"	TCPV90/3054	<input type="checkbox"/>	11.0#		
		60" 30" 30"	TCPV90/3060	<input type="checkbox"/>	11.0#		
		66" 30" 36"	TCPV90/3066	<input type="checkbox"/>	9.0#		
		72" 30" 42"	TCPV90/3072	<input type="checkbox"/>	9.0#		
		78" 30" 48"	TCPV90/3078	<input type="checkbox"/>	9.0#		
		84" 30" 54"	TCPV90/3084	<input type="checkbox"/>	9.0#		
		42" 36" 6"	TCPV90/3642	<input type="checkbox"/>	9.0#		
		48" 36" 12"	TCPV90/3648	<input type="checkbox"/>	9.0#		
		54" 36" 18"	TCPV90/3654	<input type="checkbox"/>	11.0#		
		60" 36" 24"	TCPV90/3660	<input type="checkbox"/>	11.0#		
		66" 36" 30"	TCPV90/3666	<input type="checkbox"/>	9.0#		
		72" 36" 36"	TCPV90/3672	<input type="checkbox"/>	9.0#		
		78" 36" 42"	TCPV90/3678	<input type="checkbox"/>	9.0#		
		84" 36" 48"	TCPV90/3684	<input type="checkbox"/>	9.0#		
		48" 42" 6"	TCPV90/4248	<input type="checkbox"/>	12.0#		
		54" 42" 12"	TCPV90/4254	<input type="checkbox"/>	12.0#		
		60" 42" 18"	TCPV90/4260	<input type="checkbox"/>	11.0#		
66" 42" 24"	TCPV90/4266	<input type="checkbox"/>	14.0#				
72" 42" 30"	TCPV90/4272	<input type="checkbox"/>	9.0#				
78" 42" 36"	TCPV90/4278	<input type="checkbox"/>	9.0#				
84" 42" 42"	TCPV90/4284	<input type="checkbox"/>	9.0#				

A

B

HOW TO ORDER

Indicate the following information on order form:

1. Quantity of each item.
2. Model number, including options. See "How To Build a Model Number".
3. Any special service required.

Note: • The indicates that a choice is required.

- The absence of the indicates that no choice is required.
- Alpha-numeric characters in place of indicate that no other alternatives are available.

HOW TO BUILD A MODEL NUMBER

A Select basic model.

B Select trim color.

Refer to the **Product Color Options** page in this catalog.
SX Starlight Silver finish is only offered on flat aluminum trim.

Tech Preconfigured Intersection Conditions

90° 2-Way

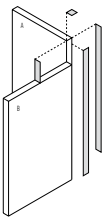
	MODEL	A	B	A-B	MODEL NUMBER		Approx. Packaged Weight
					Basic Model	Trim Color	
 <p>TECN</p>	90° 2-Way "L" Corner, Two Different Heights	54"	48"	6"	TCPV90/4854	<input type="checkbox"/>	12.0#
		60"	48"	12"	TCPV90/4860	<input type="checkbox"/>	11.0#
	• Unupholstered	66"	48"	18"	TCPV90/4866	<input type="checkbox"/>	14.0#
	• 1-way top cap	72"	48"	24"	TCPV90/4872	<input type="checkbox"/>	9.0#
	• Two pieces of universal trim (Tech)	78"	48"	30"	TCPV90/4878	<input type="checkbox"/>	9.0#
	• One piece of universal height change trim	84"	48"	36"	TCPV90/4884	<input type="checkbox"/>	9.0#
	• One half-post (height A)	60"	54"	6"	TCPV90/5460	<input type="checkbox"/>	11.0#
	• One half-post (height B)	66"	54"	12"	TCPV90/5466	<input type="checkbox"/>	15.0#
	• Two sets of half post base tile hooks	72"	54"	18"	TCPV90/5472	<input type="checkbox"/>	9.0#
	• Connecting hardware	78"	54"	24"	TCPV90/5478	<input type="checkbox"/>	9.0#
	• SX Starlight Silver finish is only offered on flat aluminum trim	84"	54"	30"	TCPV90/5484	<input type="checkbox"/>	9.0#
		66"	60"	6"	TCPV90/6066	<input type="checkbox"/>	15.0#
		72"	60"	12"	TCPV90/6072	<input type="checkbox"/>	9.0#
		78"	60"	18"	TCPV90/6078	<input type="checkbox"/>	9.0#
		84"	60"	24"	TCPV90/6084	<input type="checkbox"/>	9.0#
		72"	66"	6"	TCPV90/6672	<input type="checkbox"/>	9.0#
		78"	66"	12"	TCPV90/6678	<input type="checkbox"/>	9.0#
		84"	66"	18"	TCPV90/6684	<input type="checkbox"/>	9.0#
		78"	72"	6"	TCPV90/7278	<input type="checkbox"/>	9.0#
		84"	72"	12"	TCPV90/7284	<input type="checkbox"/>	9.0#
	84"	78"	6"	TCPV90/7884	<input type="checkbox"/>	9.0#	

A

B

HOW TO ORDER

Indicate the following information on order form:

- Quantity of each item.
- Model number, including options. See "How To Build a Model Number".
- Any special service required.

Note: • The indicates that a choice is required.

- The absence of the indicates that no choice is required.

- Alpha-numeric characters in place of indicate that no other alternatives are available.

HOW TO BUILD A MODEL NUMBER

A Select basic model.

B Select trim color.

Refer to the **Product Color Options** page in this catalog.

SX Starlight Silver finish is only offered on flat aluminum trim.

Tech Preconfigured Intersection Conditions

90° 2-Way

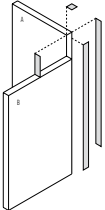
	MODEL	A	B	A-B	MODEL NUMBER			Approx. Packaged Weight
					Basic Model	Trim Color	Fabric Color	
 <p>TEF2</p>	90° 2-Way "L" Corner, Two Different Heights <ul style="list-style-type: none"> Upholstered 1-way top cap Two pieces of universal trim (Tech) One piece of universal height change trim One half-post (height A) One half-post (height B) Two sets of half post base tile hooks Connecting hardware SX Starlight Silver finish is only offered on flat aluminum trim 	36"	30"	6"	TCPVF90/3036	<input type="checkbox"/>	<input type="checkbox"/> <input type="checkbox"/> <input type="checkbox"/> <input type="checkbox"/>	9.0#
		42"	30"	12"	TCPVF90/3042	<input type="checkbox"/>	<input type="checkbox"/> <input type="checkbox"/> <input type="checkbox"/> <input type="checkbox"/>	9.0#
		48"	30"	18"	TCPVF90/3048	<input type="checkbox"/>	<input type="checkbox"/> <input type="checkbox"/> <input type="checkbox"/> <input type="checkbox"/>	9.0#
		54"	30"	24"	TCPVF90/3054	<input type="checkbox"/>	<input type="checkbox"/> <input type="checkbox"/> <input type="checkbox"/> <input type="checkbox"/>	11.0#
		60"	30"	30"	TCPVF90/3060	<input type="checkbox"/>	<input type="checkbox"/> <input type="checkbox"/> <input type="checkbox"/> <input type="checkbox"/>	11.0#
		66"	30"	36"	TCPVF90/3066	<input type="checkbox"/>	<input type="checkbox"/> <input type="checkbox"/> <input type="checkbox"/> <input type="checkbox"/>	16.0#
		72"	30"	42"	TCPVF90/3072	<input type="checkbox"/>	<input type="checkbox"/> <input type="checkbox"/> <input type="checkbox"/> <input type="checkbox"/>	16.0#
		78"	30"	48"	TCPVF90/3078	<input type="checkbox"/>	<input type="checkbox"/> <input type="checkbox"/> <input type="checkbox"/> <input type="checkbox"/>	16.0#
		84"	30"	54"	TCPVF90/3084	<input type="checkbox"/>	<input type="checkbox"/> <input type="checkbox"/> <input type="checkbox"/> <input type="checkbox"/>	16.0#
		42"	36"	6"	TCPVF90/3642	<input type="checkbox"/>	<input type="checkbox"/> <input type="checkbox"/> <input type="checkbox"/> <input type="checkbox"/>	9.0#
		48"	36"	12"	TCPVF90/3648	<input type="checkbox"/>	<input type="checkbox"/> <input type="checkbox"/> <input type="checkbox"/> <input type="checkbox"/>	9.0#
		54"	36"	18"	TCPVF90/3654	<input type="checkbox"/>	<input type="checkbox"/> <input type="checkbox"/> <input type="checkbox"/> <input type="checkbox"/>	11.0#
		60"	36"	24"	TCPVF90/3660	<input type="checkbox"/>	<input type="checkbox"/> <input type="checkbox"/> <input type="checkbox"/> <input type="checkbox"/>	11.0#
		66"	36"	30"	TCPVF90/3666	<input type="checkbox"/>	<input type="checkbox"/> <input type="checkbox"/> <input type="checkbox"/> <input type="checkbox"/>	16.0#
		72"	36"	36"	TCPVF90/3672	<input type="checkbox"/>	<input type="checkbox"/> <input type="checkbox"/> <input type="checkbox"/> <input type="checkbox"/>	16.0#
		78"	36"	42"	TCPVF90/3678	<input type="checkbox"/>	<input type="checkbox"/> <input type="checkbox"/> <input type="checkbox"/> <input type="checkbox"/>	16.0#
		84"	36"	48"	TCPVF90/3684	<input type="checkbox"/>	<input type="checkbox"/> <input type="checkbox"/> <input type="checkbox"/> <input type="checkbox"/>	16.0#
		48"	42"	6"	TCPVF90/4248	<input type="checkbox"/>	<input type="checkbox"/> <input type="checkbox"/> <input type="checkbox"/> <input type="checkbox"/>	12.0#
		54"	42"	12"	TCPVF90/4254	<input type="checkbox"/>	<input type="checkbox"/> <input type="checkbox"/> <input type="checkbox"/> <input type="checkbox"/>	12.0#
		60"	42"	18"	TCPVF90/4260	<input type="checkbox"/>	<input type="checkbox"/> <input type="checkbox"/> <input type="checkbox"/> <input type="checkbox"/>	11.0#
		66"	42"	24"	TCPVF90/4266	<input type="checkbox"/>	<input type="checkbox"/> <input type="checkbox"/> <input type="checkbox"/> <input type="checkbox"/>	14.0#
		72"	42"	30"	TCPVF90/4272	<input type="checkbox"/>	<input type="checkbox"/> <input type="checkbox"/> <input type="checkbox"/> <input type="checkbox"/>	16.0#
		78"	42"	36"	TCPVF90/4278	<input type="checkbox"/>	<input type="checkbox"/> <input type="checkbox"/> <input type="checkbox"/> <input type="checkbox"/>	16.0#
		84"	42"	42"	TCPVF90/4284	<input type="checkbox"/>	<input type="checkbox"/> <input type="checkbox"/> <input type="checkbox"/> <input type="checkbox"/>	16.0#

A

B

C

HOW TO ORDER

Indicate the following information on order form:

- Quantity of each item.
- Model number, including options. See "How To Build a Model Number".
- Any special service required.

Note: • The indicates that a choice is required.

- The absence of the indicates that no choice is required.
- Alpha-numeric characters in place of indicate that no other alternatives are available.

HOW TO BUILD A MODEL NUMBER

A Select basic model.

B Select trim color.
Refer to the **Product Color Options** page in this catalog.
SX Starlight Silver finish is only offered on flat aluminum trim.

C Select fabric color.

Tech Preconfigured Intersection Conditions

90° 2-Way

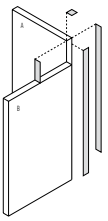
	MODEL	A	B	A-B	MODEL NUMBER			Approx. Packaged Weight			
					Basic Model	Trim Color	Fabric Color				
 <p>TEF2</p>	90° 2-Way "L" Corner, Two Different Heights	54"	48"	6"	TCPVF90/4854	<input type="checkbox"/>	<input type="checkbox"/>	<input type="checkbox"/>	<input type="checkbox"/>	12.0#	
	<ul style="list-style-type: none"> Upholstered 1-way top cap Two pieces of universal trim (Tech) One piece of universal height change trim One half-post (height A) One half-post (height B) Two sets of half post base tile hooks Connecting hardware SX Starlight Silver finish is only offered on flat aluminum trim 	60"	48"	12"	TCPVF90/4860	<input type="checkbox"/>	<input type="checkbox"/>	<input type="checkbox"/>	<input type="checkbox"/>	11.0#	
			66"	48"	18"	TCPVF90/4866	<input type="checkbox"/>	<input type="checkbox"/>	<input type="checkbox"/>	<input type="checkbox"/>	14.0#
			72"	48"	24"	TCPVF90/4872	<input type="checkbox"/>	<input type="checkbox"/>	<input type="checkbox"/>	<input type="checkbox"/>	16.0#
			78"	48"	30"	TCPVF90/4878	<input type="checkbox"/>	<input type="checkbox"/>	<input type="checkbox"/>	<input type="checkbox"/>	16.0#
			84"	48"	36"	TCPVF90/4884	<input type="checkbox"/>	<input type="checkbox"/>	<input type="checkbox"/>	<input type="checkbox"/>	16.0#
			60"	54"	6"	TCPVF90/5460	<input type="checkbox"/>	<input type="checkbox"/>	<input type="checkbox"/>	<input type="checkbox"/>	11.0#
			66"	54"	12"	TCPVF90/5466	<input type="checkbox"/>	<input type="checkbox"/>	<input type="checkbox"/>	<input type="checkbox"/>	15.0#
			72"	54"	18"	TCPVF90/5472	<input type="checkbox"/>	<input type="checkbox"/>	<input type="checkbox"/>	<input type="checkbox"/>	16.0#
			78"	54"	24"	TCPVF90/5478	<input type="checkbox"/>	<input type="checkbox"/>	<input type="checkbox"/>	<input type="checkbox"/>	16.0#
			84"	54"	30"	TCPVF90/5484	<input type="checkbox"/>	<input type="checkbox"/>	<input type="checkbox"/>	<input type="checkbox"/>	16.0#
			66"	60"	6"	TCPVF90/6066	<input type="checkbox"/>	<input type="checkbox"/>	<input type="checkbox"/>	<input type="checkbox"/>	15.0#
			72"	60"	12"	TCPVF90/6072	<input type="checkbox"/>	<input type="checkbox"/>	<input type="checkbox"/>	<input type="checkbox"/>	16.0#
			78"	60"	18"	TCPVF90/6078	<input type="checkbox"/>	<input type="checkbox"/>	<input type="checkbox"/>	<input type="checkbox"/>	16.0#
			84"	60"	24"	TCPVF90/6084	<input type="checkbox"/>	<input type="checkbox"/>	<input type="checkbox"/>	<input type="checkbox"/>	16.0#
			72"	66"	6"	TCPVF90/6672	<input type="checkbox"/>	<input type="checkbox"/>	<input type="checkbox"/>	<input type="checkbox"/>	16.0#
			78"	66"	12"	TCPVF90/6678	<input type="checkbox"/>	<input type="checkbox"/>	<input type="checkbox"/>	<input type="checkbox"/>	16.0#
			84"	66"	18"	TCPVF90/6684	<input type="checkbox"/>	<input type="checkbox"/>	<input type="checkbox"/>	<input type="checkbox"/>	16.0#
			78"	72"	6"	TCPVF90/7278	<input type="checkbox"/>	<input type="checkbox"/>	<input type="checkbox"/>	<input type="checkbox"/>	16.0#
			84"	72"	12"	TCPVF90/7284	<input type="checkbox"/>	<input type="checkbox"/>	<input type="checkbox"/>	<input type="checkbox"/>	16.0#
		84"	78"	6"	TCPVF90/7884	<input type="checkbox"/>	<input type="checkbox"/>	<input type="checkbox"/>	<input type="checkbox"/>	16.0#	

A

B

C

HOW TO ORDER

Indicate the following information on order form:

- Quantity of each item.
- Model number, including options. See "How To Build a Model Number".
- Any special service required.

Note: • The indicates that a choice is required.

- The absence of the indicates that no choice is required.
- Alpha-numeric characters in place of indicate that no other alternatives are available.

HOW TO BUILD A MODEL NUMBER

- A** Select basic model.
- B** Select trim color.
Refer to the **Product Color Options** page in this catalog.
SX Starlight Silver finish is only offered on flat aluminum trim.
- C** Select fabric color.

Tech Preconfigured Intersection Conditions

180° 2-Way

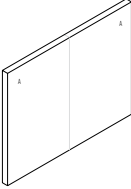
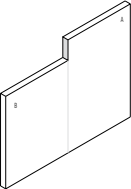
	MODEL	A	B	A-B	MODEL NUMBER		Approx. Packaged Weight
					Basic Model	Trim Color	
 <p>TECN</p>	180° 2-Way In-Line Connection, Both Panels Same Height <ul style="list-style-type: none"> • Unupholstered • One full post • Two sets of half post base tile hooks 	30"			TFP/30		5.0#
		36"			TFP/36		5.0#
		42"			TFP/42		6.0#
		48"			TFP/48		6.0#
		54"			TFP/54		7.0#
		60"			TFP/60		7.0#
		66"			TFP/66		8.0#
		72"			TFP/72		9.0#
		78"			TFP/78		10.0#
		84"			TFP/84		11.0#
 <p>TECN</p>	180° 2-Way In-Line Connection, Two Different Heights <ul style="list-style-type: none"> • Unupholstered: trim colored • One full post • In-line height change trim • In-line height change bottom cap • End-of-run top cap • Two sets of half post base tile hooks • SX Starlight Silver finish is only offered on flat aluminum trim 	36" 30" 6"			TFPV/3036	<input type="checkbox"/>	5.0#
		42" 30" 12"			TFPV/3042	<input type="checkbox"/>	6.0#
		54" 30" 24"			TFPV/3054	<input type="checkbox"/>	7.0#
		66" 30" 36"			TFPV/3066	<input type="checkbox"/>	8.0#
		84" 30" 54"			TFPV/3084	<input type="checkbox"/>	11.0#
		66" 42" 24"			TFPV/4266	<input type="checkbox"/>	8.0#
		84" 42" 42"			TFPV/4284	<input type="checkbox"/>	11.0#
		66" 54" 12"			TFPV/5466	<input type="checkbox"/>	8.0#
		84" 54" 30"			TFPV/5484	<input type="checkbox"/>	11.0#
		84" 66" 18"			TFPV/6684	<input type="checkbox"/>	10.0#

A

B

HOW TO ORDER

Indicate the following information on order form:

1. Quantity of each item.
2. Model number, including options. See "How To Build a Model Number".
3. Any special service required.

Note:

- The indicates that a choice is required.
- The absence of the indicates that no choice is required.
- Alpha-numeric characters in place of indicate that no other alternatives are available.

HOW TO BUILD A MODEL NUMBER

A Select basic model.

B Select trim color.
Refer to the **Product Color Options** page in this catalog.
SX Starlight Silver finish is only offered on flat aluminum trim.

Tech Preconfigured Intersection Conditions

180° 2-Way

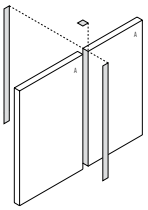
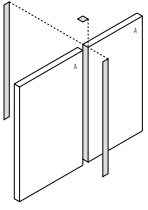
	MODEL	H	MODEL NUMBER			Approx. Packaged Weight
			Basic Model	Trim Color	Fabric Color	
 <p>TECN</p>	180° 2-Way In-Line Spacer, Both Panels Same Height <ul style="list-style-type: none"> Unupholstered: trim colored 180° top cap Two pieces of universal trim (Tech) Two half-posts Two sets of half post base tile hooks Connecting hardware SX Starlight Silver finish is only offered on flat aluminum trim 	30"	TSP180/30	<input type="checkbox"/>		4.0#
		36"	TSP180/36	<input type="checkbox"/>		4.0#
		42"	TSP180/42	<input type="checkbox"/>		5.0#
		48"	TSP180/48	<input type="checkbox"/>		5.0#
		54"	TSP180/54	<input type="checkbox"/>		6.0#
		60"	TSP180/60	<input type="checkbox"/>		6.0#
		66"	TSP180/66	<input type="checkbox"/>		7.0#
		72"	TSP180/72	<input type="checkbox"/>		7.0#
		78"	TSP180/78	<input type="checkbox"/>		7.0#
		84"	TSP180/84	<input type="checkbox"/>		7.0#
 <p>TEF2</p>	180° 2-Way In-Line Spacer, Both Panels Same Height <ul style="list-style-type: none"> Upholstered 180° top cap Two pieces of universal trim (Tech) Two half-posts Two sets of half post base tile hooks Connecting hardware SX Starlight Silver finish is only offered on flat aluminum trim 	30"	TSPF180/30	<input type="checkbox"/>	<input type="checkbox"/> <input type="checkbox"/> <input type="checkbox"/> <input type="checkbox"/>	4.0#
		36"	TSPF180/36	<input type="checkbox"/>	<input type="checkbox"/> <input type="checkbox"/> <input type="checkbox"/> <input type="checkbox"/>	4.0#
		42"	TSPF180/42	<input type="checkbox"/>	<input type="checkbox"/> <input type="checkbox"/> <input type="checkbox"/> <input type="checkbox"/>	5.0#
		48"	TSPF180/48	<input type="checkbox"/>	<input type="checkbox"/> <input type="checkbox"/> <input type="checkbox"/> <input type="checkbox"/>	5.0#
		54"	TSPF180/54	<input type="checkbox"/>	<input type="checkbox"/> <input type="checkbox"/> <input type="checkbox"/> <input type="checkbox"/>	6.0#
		60"	TSPF180/60	<input type="checkbox"/>	<input type="checkbox"/> <input type="checkbox"/> <input type="checkbox"/> <input type="checkbox"/>	6.0#
		66"	TSPF180/66	<input type="checkbox"/>	<input type="checkbox"/> <input type="checkbox"/> <input type="checkbox"/> <input type="checkbox"/>	7.0#
		72"	TSPF180/72	<input type="checkbox"/>	<input type="checkbox"/> <input type="checkbox"/> <input type="checkbox"/> <input type="checkbox"/>	7.0#
		78"	TSPF180/78	<input type="checkbox"/>	<input type="checkbox"/> <input type="checkbox"/> <input type="checkbox"/> <input type="checkbox"/>	7.0#
		84"	TSPF180/84	<input type="checkbox"/>	<input type="checkbox"/> <input type="checkbox"/> <input type="checkbox"/> <input type="checkbox"/>	7.0#

A

B

C

HOW TO ORDER

Indicate the following information on order form:

- Quantity of each item.
- Model number, including options. See "How To Build a Model Number".
- Any special service required.

Note: • The indicates that a choice is required.

- The absence of the indicates that no choice is required.
- Alpha-numeric characters in place of indicate that no other alternatives are available.

HOW TO BUILD A MODEL NUMBER

A Select basic model.

B Select trim color.
Refer to the **Product Color Options** page in this catalog.
SX Starlight Silver finish is only offered on flat aluminum trim.

C Select fabric color.

Tech Preconfigured Intersection Conditions

180° 2-Way

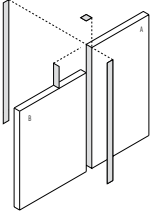
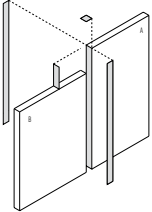
	MODEL	A	B	A-B	MODEL NUMBER			Approx. Packaged Weight
					Basic Model	Trim Color	Fabric Color	
 <p>TECN</p>	180° 2-Way In-Line Spacer, Two Different Heights <ul style="list-style-type: none"> • Unupholstered: trim colored • Dead end top cap • Two pieces of universal trim (Tech) • One piece of universal height change trim • One half-post (height A) • One half-post (height B) • Two sets of half post base tile hooks • Connecting hardware • SX Starlight Silver finish is only offered on flat aluminum trim 	36"	30"	6"	TPV180/3036	<input type="checkbox"/>		9.0#
		42"	30"	12"	TPV180/3042	<input type="checkbox"/>		9.0#
		54"	30"	24"	TPV180/3054	<input type="checkbox"/>		11.0#
		66"	30"	36"	TPV180/3066	<input type="checkbox"/>		13.0#
		84"	30"	54"	TPV180/3084	<input type="checkbox"/>		16.0#
		66"	42"	24"	TPV180/4266	<input type="checkbox"/>		14.0#
		84"	42"	42"	TPV180/4284	<input type="checkbox"/>		17.0#
		66"	54"	12"	TPV180/5466	<input type="checkbox"/>		15.0#
		84"	54"	30"	TPV180/5484	<input type="checkbox"/>		18.0#
		84"	66"	18"	TPV180/6684	<input type="checkbox"/>		19.0#
 <p>TEF2</p>	180° 2-Way In-Line Spacer, Two Different Heights <ul style="list-style-type: none"> • Upholstered • Dead end top cap • Two pieces of universal trim (Tech) • One piece of universal height change trim • One half-post (height A) • One half-post (height B) • Two sets of half post base tile hooks • Connecting hardware • SX Starlight Silver finish is only offered on flat aluminum trim 	36"	30"	6"	TSPVF180/3036	<input type="checkbox"/>	<input type="checkbox"/> <input type="checkbox"/> <input type="checkbox"/> <input type="checkbox"/>	9.0#
		42"	30"	12"	TSPVF180/3042	<input type="checkbox"/>	<input type="checkbox"/> <input type="checkbox"/> <input type="checkbox"/> <input type="checkbox"/>	9.0#
		54"	30"	24"	TSPVF180/3054	<input type="checkbox"/>	<input type="checkbox"/> <input type="checkbox"/> <input type="checkbox"/> <input type="checkbox"/>	11.0#
		66"	30"	36"	TSPVF180/3066	<input type="checkbox"/>	<input type="checkbox"/> <input type="checkbox"/> <input type="checkbox"/> <input type="checkbox"/>	13.0#
		84"	30"	54"	TSPVF180/3084	<input type="checkbox"/>	<input type="checkbox"/> <input type="checkbox"/> <input type="checkbox"/> <input type="checkbox"/>	16.0#
		66"	42"	24"	TSPVF180/4266	<input type="checkbox"/>	<input type="checkbox"/> <input type="checkbox"/> <input type="checkbox"/> <input type="checkbox"/>	14.0#
		84"	42"	42"	TSPVF180/4284	<input type="checkbox"/>	<input type="checkbox"/> <input type="checkbox"/> <input type="checkbox"/> <input type="checkbox"/>	17.0#
		66"	54"	12"	TSPVF180/5466	<input type="checkbox"/>	<input type="checkbox"/> <input type="checkbox"/> <input type="checkbox"/> <input type="checkbox"/>	15.0#
		84"	54"	30"	TSPVF180/5484	<input type="checkbox"/>	<input type="checkbox"/> <input type="checkbox"/> <input type="checkbox"/> <input type="checkbox"/>	18.0#
		84"	66"	18"	TSPVF180/6684	<input type="checkbox"/>	<input type="checkbox"/> <input type="checkbox"/> <input type="checkbox"/> <input type="checkbox"/>	19.0#

A **B** **C**

HOW TO ORDER

Indicate the following information on order form:

1. Quantity of each item.
2. Model number, including options. See "How To Build a Model Number".
3. Any special service required.

- Note:
- The indicates that a choice is required.
 - The absence of the indicates that no choice is required.
 - Alpha-numeric characters in place of indicate that no other alternatives are available.

HOW TO BUILD A MODEL NUMBER

- A** Select basic model.
- B** Select trim color.
Refer to the **Product Color Options** page in this catalog.
SX Starlight Silver finish is only offered on flat aluminum trim.
- C** Select fabric color.

Tech Preconfigured Intersection Conditions

3-Way

	MODEL	H	MODEL NUMBER			Approx. Packaged Weight
			Basic Model	Trim Color	Fabric Color	
 TECN	3-Way "T" Intersection w/3-Way Cap, All Panels Same Height <ul style="list-style-type: none"> • Upholstered: trim colored • 3-way top cap • One piece of universal trim (Tech) • Three half-posts • Three sets of half post base tile hooks • Connecting hardware • SX Starlight Silver finish is only offered on flat aluminum trim 	30"	TTP3W/30	<input type="checkbox"/>		10.0#
		36"	TTP3W/36	<input type="checkbox"/>		11.0#
		42"	TTP3W/42	<input type="checkbox"/>		12.0#
		48"	TTP3W/48	<input type="checkbox"/>		14.0#
		54"	TTP3W/54	<input type="checkbox"/>		15.0#
		60"	TTP3W/60	<input type="checkbox"/>		17.0#
		66"	TTP3W/66	<input type="checkbox"/>		18.0#
		72"	TTP3W/72	<input type="checkbox"/>		18.0#
		78"	TTP3W/78	<input type="checkbox"/>		18.0#
		84"	TTP3W/84	<input type="checkbox"/>		18.0#
 TEF1	3-Way "T" Intersection w/3-Way Cap, All Panels Same Height <ul style="list-style-type: none"> • Upholstered • 3-way top cap • One piece of universal trim (Tech) • Three half-posts • Three sets of half post base tile hooks • Connecting hardware • SX Starlight Silver finish is only offered on flat aluminum trim 	30"	TTPF3W/30	<input type="checkbox"/>	<input type="checkbox"/> <input type="checkbox"/> <input type="checkbox"/> <input type="checkbox"/>	9.0#
		36"	TTPF3W/36	<input type="checkbox"/>	<input type="checkbox"/> <input type="checkbox"/> <input type="checkbox"/> <input type="checkbox"/>	9.0#
		42"	TTPF3W/42	<input type="checkbox"/>	<input type="checkbox"/> <input type="checkbox"/> <input type="checkbox"/> <input type="checkbox"/>	12.0#
		48"	TTPF3W/48	<input type="checkbox"/>	<input type="checkbox"/> <input type="checkbox"/> <input type="checkbox"/> <input type="checkbox"/>	12.0#
		54"	TTPF3W/54	<input type="checkbox"/>	<input type="checkbox"/> <input type="checkbox"/> <input type="checkbox"/> <input type="checkbox"/>	15.0#
		60"	TTPF3W/60	<input type="checkbox"/>	<input type="checkbox"/> <input type="checkbox"/> <input type="checkbox"/> <input type="checkbox"/>	15.0#
		66"	TTPF3W/66	<input type="checkbox"/>	<input type="checkbox"/> <input type="checkbox"/> <input type="checkbox"/> <input type="checkbox"/>	18.0#
		72"	TTPF3W/72	<input type="checkbox"/>	<input type="checkbox"/> <input type="checkbox"/> <input type="checkbox"/> <input type="checkbox"/>	18.0#
		78"	TTPF3W/78	<input type="checkbox"/>	<input type="checkbox"/> <input type="checkbox"/> <input type="checkbox"/> <input type="checkbox"/>	18.0#
		84"	TTPF3W/84	<input type="checkbox"/>	<input type="checkbox"/> <input type="checkbox"/> <input type="checkbox"/> <input type="checkbox"/>	18.0#

A

B

C

HOW TO ORDER

Indicate the following information on order form:

1. Quantity of each item.
2. Model number, including options. See "How To Build a Model Number".
3. Any special service required.

Note: • The indicates that a choice is required.

- The absence of the indicates that no choice is required.
- Alpha-numeric characters in place of indicate that no other alternatives are available.

HOW TO BUILD A MODEL NUMBER

A Select basic model.

B Select trim color.
Refer to the **Product Color Options** page in this catalog.
SX Starlight Silver finish is only offered on flat aluminum trim.

C Select fabric color.

Tech Preconfigured Intersection Conditions

3-Way

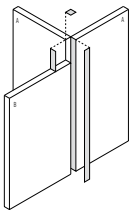
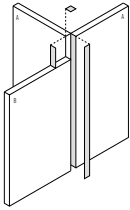
	MODEL	A	B	A-B	MODEL NUMBER			Approx. Packaged Weight
					Basic Model	Trim Color	Fabric Color	
 <p>TECN</p>	3-Way "T" Intersection w/90° Top Cap, Two Different Heights <ul style="list-style-type: none"> • Unupholstered: trim colored • 90° top cap • One piece of universal trim (Tech) • One piece of universal height change trim • Light block • Two half-posts (height A) • One half-post (height B) • Three sets of half post base tile hooks • Connecting hardware • SX Starlight Silver finish is only offered on flat aluminum trim 	36" 30" 6"	TTPV90/3036	<input type="checkbox"/>		15.0#		
		42" 30" 12"	TTPV90/3042	<input type="checkbox"/>		11.0#		
		54" 30" 24"	TTPV90/3054	<input type="checkbox"/>		14.0#		
		66" 30" 36"	TTPV90/3066	<input type="checkbox"/>		17.0#		
		84" 30" 54"	TTPV90/3084	<input type="checkbox"/>		21.0#		
		66" 42" 24"	TTPV90/4266	<input type="checkbox"/>		18.0#		
		84" 42" 42"	TTPV90/4284	<input type="checkbox"/>		22.0#		
		66" 54" 12"	TTPV90/5466	<input type="checkbox"/>		18.0#		
		84" 54" 30"	TTPV90/5484	<input type="checkbox"/>		22.0#		
		84" 66" 18"	TTPV90/6684	<input type="checkbox"/>		23.0#		
 <p>TEF2</p>	3-Way "T" Intersection w/90° Top Cap, Two Different Heights <ul style="list-style-type: none"> • Upholstered • 90° top cap • One piece of universal trim (Tech) • One piece of universal height change trim • Light block • Two half-posts (height A) • One half-post (height B) • Three sets of half post base tile hooks • Connecting hardware • SX Starlight Silver finish is only offered on flat aluminum trim 	36" 30" 6"	TTPVF90/3036	<input type="checkbox"/>	<input type="checkbox"/> <input type="checkbox"/> <input type="checkbox"/> <input type="checkbox"/>	15.0#		
		42" 30" 12"	TTPVF90/3042	<input type="checkbox"/>	<input type="checkbox"/> <input type="checkbox"/> <input type="checkbox"/> <input type="checkbox"/>	11.0#		
		54" 30" 24"	TTPVF90/3054	<input type="checkbox"/>	<input type="checkbox"/> <input type="checkbox"/> <input type="checkbox"/> <input type="checkbox"/>	14.0#		
		66" 30" 36"	TTPVF90/3066	<input type="checkbox"/>	<input type="checkbox"/> <input type="checkbox"/> <input type="checkbox"/> <input type="checkbox"/>	17.0#		
		84" 30" 54"	TTPVF90/3084	<input type="checkbox"/>	<input type="checkbox"/> <input type="checkbox"/> <input type="checkbox"/> <input type="checkbox"/>	21.0#		
		66" 42" 24"	TTPVF90/4266	<input type="checkbox"/>	<input type="checkbox"/> <input type="checkbox"/> <input type="checkbox"/> <input type="checkbox"/>	18.0#		
		84" 42" 43"	TTPVF90/4284	<input type="checkbox"/>	<input type="checkbox"/> <input type="checkbox"/> <input type="checkbox"/> <input type="checkbox"/>	22.0#		
		66" 54" 12"	TTPVF90/5466	<input type="checkbox"/>	<input type="checkbox"/> <input type="checkbox"/> <input type="checkbox"/> <input type="checkbox"/>	18.0#		
		84" 54" 30"	TTPVF90/5484	<input type="checkbox"/>	<input type="checkbox"/> <input type="checkbox"/> <input type="checkbox"/> <input type="checkbox"/>	22.0#		
		84" 66" 18"	TTPVF90/6684	<input type="checkbox"/>	<input type="checkbox"/> <input type="checkbox"/> <input type="checkbox"/> <input type="checkbox"/>	23.0#		

A **B** **C**

HOW TO ORDER

Indicate the following information on order form:

1. Quantity of each item.
2. Model number, including options. See "How To Build a Model Number".
3. Any special service required.

Note:

- The indicates that a choice is required.
- The absence of the indicates that no choice is required.
- Alpha-numeric characters in place of indicate that no other alternatives are available.

HOW TO BUILD A MODEL NUMBER

- A** Select basic model.
- B** Select trim color.
Refer to the **Product Color Options** page in this catalog.
SX Starlight Silver finish is only offered on flat aluminum trim.
- C** Select fabric color.

Tech Preconfigured Intersection Conditions

3-Way

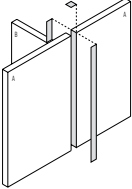
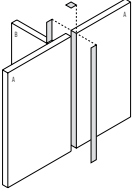
			MODEL NUMBER			Approx. Packaged Weight
MODEL	A B A-B		Basic Model	Trim Color	Fabric Color	
 <p>TECN</p>	3-Way "T" Intersection w/180° Top Cap, Two Different Heights	36" 30" 6"	TTPV180/3036	<input type="checkbox"/>		10.0#
		42" 30" 12"	TTPV180/3042	<input type="checkbox"/>		10.0#
	<ul style="list-style-type: none"> • Upholstered: trim colored 	54" 30" 24"	TTPV180/3054	<input type="checkbox"/>		12.0#
	<ul style="list-style-type: none"> • 180° top cap 	66" 30" 36"	TTPV180/3066	<input type="checkbox"/>		14.0#
	<ul style="list-style-type: none"> • One piece of universal trim (Tech) 	84" 30" 54"	TTPV180/3084	<input type="checkbox"/>		16.0#
	<ul style="list-style-type: none"> • One piece of universal height change trim 	66" 42" 24"	TTPV180/4266	<input type="checkbox"/>		16.0#
	<ul style="list-style-type: none"> • Light block 	84" 42" 42"	TTPV180/4284	<input type="checkbox"/>		18.0#
	<ul style="list-style-type: none"> • Two half-posts (height A) 	66" 54" 12"	TTPV180/5466	<input type="checkbox"/>		17.0#
	<ul style="list-style-type: none"> • One half-post (height B) 	84" 54" 30"	TTPV180/5484	<input type="checkbox"/>		19.0#
	<ul style="list-style-type: none"> • Three sets of half post base tile hooks • Connecting hardware • SX Starlight Silver finish is only offered on flat aluminum trim 	84" 66" 18"	TTPV180/6684	<input type="checkbox"/>		22.0#
 <p>TEF2</p>	3-Way "T" Intersection w/180° Top Cap, Two Different Heights	36" 30" 6"	TTPVF180/3036	<input type="checkbox"/>	<input type="checkbox"/>	10.0#
		42" 30" 12"	TTPVF180/3042	<input type="checkbox"/>	<input type="checkbox"/>	10.0#
	<ul style="list-style-type: none"> • Upholstered 	54" 30" 24"	TTPVF180/3054	<input type="checkbox"/>	<input type="checkbox"/>	12.0#
	<ul style="list-style-type: none"> • 180° top cap 	66" 30" 36"	TTPVF180/3066	<input type="checkbox"/>	<input type="checkbox"/>	14.0#
	<ul style="list-style-type: none"> • One piece of fabric-wrapped universal trim (Tech) 	84" 30" 54"	TTPVF180/3084	<input type="checkbox"/>	<input type="checkbox"/>	16.0#
	<ul style="list-style-type: none"> • One piece of fabric-wrapped universal height change trim 	66" 42" 24"	TTPVF180/4266	<input type="checkbox"/>	<input type="checkbox"/>	16.0#
	<ul style="list-style-type: none"> • Light block 	84" 42" 42"	TTPVF180/4284	<input type="checkbox"/>	<input type="checkbox"/>	18.0#
	<ul style="list-style-type: none"> • Two half-posts (height A) 	66" 54" 12"	TTPVF180/5466	<input type="checkbox"/>	<input type="checkbox"/>	17.0#
	<ul style="list-style-type: none"> • One half-post (height B) 	84" 54" 30"	TTPVF180/5484	<input type="checkbox"/>	<input type="checkbox"/>	19.0#
	<ul style="list-style-type: none"> • Three sets of half post base tile hooks • Connecting hardware • SX Starlight Silver finish is only offered on flat aluminum trim 	84" 66" 18"	TTPVF180/6684	<input type="checkbox"/>	<input type="checkbox"/>	22.0#

A **B** **C**

HOW TO ORDER

Indicate the following information on order form:

1. Quantity of each item.
2. Model number, including options. See "How To Build a Model Number".
3. Any special service required.

Note: • The indicates that a choice is required.

- The absence of the indicates that no choice is required.
- Alpha-numeric characters in place of indicate that no other alternatives are available.

HOW TO BUILD A MODEL NUMBER

- A** Select basic model.
- B** Select trim color.
Refer to the **Product Color Options** page in this catalog.
SX Starlight Silver finish is only offered on flat aluminum trim.
- C** Select fabric color.

Tech Preconfigured Intersection Conditions

4-Way

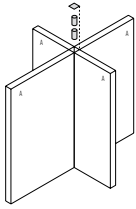
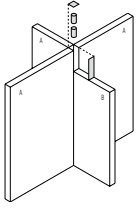
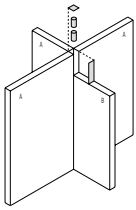
	MODEL	A	B	A-B	MODEL NUMBER				Approx. Packaged Weight
					Basic Model	Assembly	Trim Color	Fabric Color	
 <p>TECN</p>	4-Way "X" Intersection with 4-Way Top Cap, All Panels Same Height <ul style="list-style-type: none"> • Unupholstered: trim colored • 4-way top cap • Light block • Four half-posts (height A) • Four sets of half post base tile hooks • Connecting hardware • SX Starlight Silver finish is only offered on flat aluminum trim 	30"			TXP4W/30	<input type="checkbox"/>	<input type="checkbox"/>		10.0#
		36"			TXP4W/36	<input type="checkbox"/>	<input type="checkbox"/>		10.0#
		42"			TXP4W/42	<input type="checkbox"/>	<input type="checkbox"/>		14.0#
		48"			TXP4W/48	<input type="checkbox"/>	<input type="checkbox"/>		14.0#
		54"			TXP4W/54	<input type="checkbox"/>	<input type="checkbox"/>		19.0#
		60"			TXP4W/60	<input type="checkbox"/>	<input type="checkbox"/>		19.0#
		66"			TXP4W/66	<input type="checkbox"/>	<input type="checkbox"/>		23.0#
		72"			TXP4W/72	<input type="checkbox"/>	<input type="checkbox"/>		23.0#
		78"			TXP4W/78	<input type="checkbox"/>	<input type="checkbox"/>		23.0#
84"			TXP4W/84	<input type="checkbox"/>	<input type="checkbox"/>		30.0#		
 <p>TECN</p>	4-Way "X" Intersection with 3-Way Top Cap, Two Different Heights <ul style="list-style-type: none"> • Unupholstered • 3-way top cap • One piece of universal height change trim • Light block • Three half-posts (height A) • One half-post (height B) • Four sets of half post base tile hooks • Connecting hardware • SX Starlight Silver finish is only offered on flat aluminum trim 	36" 30" 6"			TXPV3W/3036		<input type="checkbox"/>		18.0#
		42" 30" 12"			TXPV3W/3042		<input type="checkbox"/>		14.0#
		54" 30" 24"			TXPV3W/3054		<input type="checkbox"/>		17.0#
		66" 30" 36"			TXPV3W/3066		<input type="checkbox"/>		20.0#
		84" 30" 54"			TXPV3W/3084		<input type="checkbox"/>		26.0#
		66" 42" 36"			TXPV3W/4266		<input type="checkbox"/>		21.0#
		84" 42" 42"			TXPV3W/4284		<input type="checkbox"/>		27.0#
		66" 54" 12"			TXPV3W/5466		<input type="checkbox"/>		22.0#
		84" 54" 30"			TXPV3W/5484		<input type="checkbox"/>		28.0#
84" 66" 18"			TXPV3W/6684		<input type="checkbox"/>		29.0#		
 <p>TEF2</p>	4-Way "X" Intersection with 3-Way Top Cap, Two Different Heights <ul style="list-style-type: none"> • Upholstered • 3-way top cap • One piece of universal height change trim • Light block • Three half-posts (height A) • One half-post (height B) • Four sets of half post base tile hooks • Connecting hardware • SX Starlight Silver finish is only offered on flat aluminum trim 	36" 30" 6"			TXPVF3W/3036		<input type="checkbox"/>	<input type="checkbox"/>	18.0#
		42" 30" 12"			TXPVF3W/3042		<input type="checkbox"/>	<input type="checkbox"/>	14.0#
		54" 30" 24"			TXPVF3W/3054		<input type="checkbox"/>	<input type="checkbox"/>	17.0#
		66" 30" 36"			TXPVF3W/3066		<input type="checkbox"/>	<input type="checkbox"/>	20.0#
		84" 30" 54"			TXPVF3W/3084		<input type="checkbox"/>	<input type="checkbox"/>	26.0#
		66" 42" 24"			TXPVF3W/4266		<input type="checkbox"/>	<input type="checkbox"/>	21.0#
		84" 42" 42"			TXPVF3W/4284		<input type="checkbox"/>	<input type="checkbox"/>	27.0#
		66" 54" 12"			TXPVF3W/5466		<input type="checkbox"/>	<input type="checkbox"/>	22.0#
		84" 54" 30"			TXPVF3W/5484		<input type="checkbox"/>	<input type="checkbox"/>	28.0#
84" 66" 18"			TXPVF3W/6684		<input type="checkbox"/>	<input type="checkbox"/>	29.0#		

A **B** **C** **D**

HOW TO ORDER

Indicate the following information on order form:

1. Quantity of each item.
2. Model number, including options. See "How To Build a Model Number".
3. Any special service required.

- Note:
- The indicates that a choice is required.
 - The absence of the indicates that no choice is required.
 - Alpha-numeric characters in place of indicate that no other alternatives are available.

HOW TO BUILD A MODEL NUMBER

- A** Select basic model.
- B** Select assembly.

F	- Fully Assembled
U	- Unassembled
- C** Select trim color. Refer to the **Product Color Options** page in this catalog. SX Starlight Silver finish is only offered on flat aluminum trim.
- D** Select fabric color.

Tech Preconfigured Intersection Conditions

4-Way

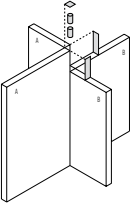
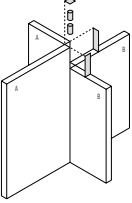
			MODEL NUMBER			Approx. Packaged Weight	
MODEL	A	B	A-B	Basic Model	Trim Color		Fabric Color
 <p>TECN</p>	4-Way "X" Intersection with 90° Top Cap, Two Different Heights						
		36"	30"	6"	TXPV90/3036	<input type="checkbox"/>	
		42"	30"	12"	TXPV90/3042	<input type="checkbox"/>	
	• Unupholstered: trim colored	54"	30"	24"	TXPV90/3054	<input type="checkbox"/>	
	• 90° top cap	66"	30"	36"	TXPV90/3066	<input type="checkbox"/>	
	• Two pieces of universal height change trim	84"	30"	54"	TXPV90/3084	<input type="checkbox"/>	
	• Light block	66"	42"	24"	TXPV90/4266	<input type="checkbox"/>	
	• Two half-posts (height B)	84"	42"	42"	TXPV90/4284	<input type="checkbox"/>	
	• Two half-posts (height A)	66"	54"	12"	TXPV90/5466	<input type="checkbox"/>	
	• Three sets of half post base tile hooks	84"	54"	30"	TXPV90/5484	<input type="checkbox"/>	
	• Connecting hardware	84"	66"	18"	TXPV90/6684	<input type="checkbox"/>	
• SX Starlight Silver finish is only offered on flat aluminum trim							
 <p>TEF2</p>	4-Way "X" Intersection with 90° Top Cap, Two Different Heights						
		36"	30"	6"	TXPVF90/3036	<input type="checkbox"/>	<input type="checkbox"/>
		42"	30"	12"	TXPVF90/3042	<input type="checkbox"/>	<input type="checkbox"/>
	• Upholstered: trim colored	54"	30"	24"	TXPVF90/3054	<input type="checkbox"/>	<input type="checkbox"/>
	• 90° top cap	66"	30"	36"	TXPVF90/3066	<input type="checkbox"/>	<input type="checkbox"/>
	• Two pieces of universal height change trim	84"	30"	54"	TXPVF90/3084	<input type="checkbox"/>	<input type="checkbox"/>
	• Light block	66"	42"	24"	TXPVF90/4266	<input type="checkbox"/>	<input type="checkbox"/>
	• Two half-posts (height A)	84"	42"	42"	TXPVF90/4284	<input type="checkbox"/>	<input type="checkbox"/>
	• Two half-posts (height B)	66"	54"	12"	TXPVF90/5466	<input type="checkbox"/>	<input type="checkbox"/>
	• Four sets of half post base tile hooks	84"	54"	30"	TXPVF90/5484	<input type="checkbox"/>	<input type="checkbox"/>
	• Connecting hardware	84"	66"	18"	TXPVF90/6684	<input type="checkbox"/>	<input type="checkbox"/>
• SX Starlight Silver finish is only offered on flat aluminum trim							

A**B****C**

HOW TO ORDER

Indicate the following information on order form:

- Quantity of each item.
- Model number, including options. See "How To Build a Model Number".
- Any special service required.

Note: • The indicates that a choice is required.

- The absence of the indicates that no choice is required.
- Alpha-numeric characters in place of indicate that no other alternatives are available.

HOW TO BUILD A MODEL NUMBER

- A** Select basic model.
- B** Select trim color.
Refer to the **Product Color Options** page in this catalog.
SX Starlight Silver finish is only offered on flat aluminum trim.
- C** Select fabric color.

Tech Preconfigured Intersection Conditions

4-Way

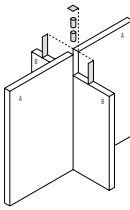
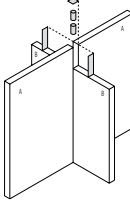
	MODEL	A	B	A-B	MODEL NUMBER			Approx. Packaged Weight
					Basic Model	Trim Color	Fabric Color	
 <p>TECN</p>	4-Way "X" Intersection with 180° Top Cap, Two Different Heights	36"	30"	6"	TXPV180/3036	<input type="checkbox"/>		17.0#
		42"	30"	12"	TXPV180/3042	<input type="checkbox"/>		13.0#
	• Unupholstered: trim colored	54"	30"	24"	TXPV180/3054	<input type="checkbox"/>		16.0#
	• 180° top cap	66"	30"	36"	TXPV180/3066	<input type="checkbox"/>		19.0#
	• Two pieces of universal height change trim	84"	30"	54"	TXPV180/3084	<input type="checkbox"/>		23.0#
	• Light block	66"	42"	24"	TXPV180/4266	<input type="checkbox"/>		20.0#
	• Two half-posts (height A)	84"	42"	42"	TXPV180/4284	<input type="checkbox"/>		25.0#
	• Two half-posts (height B)	66"	54"	12"	TXPV180/5466	<input type="checkbox"/>		21.0#
	• Four sets of half post base tile hooks	84"	54"	30"	TXPV180/5484	<input type="checkbox"/>		26.0#
	• Connecting hardware	84"	66"	18"	TXPV180/6684	<input type="checkbox"/>		27.0#
• SX Starlight Silver finish is only offered on flat aluminum trim								
 <p>TEF2</p>	4-Way "X" Intersection with 180° Top Cap, Two Different Heights	36"	30"	6"	TXPVF180/3036	<input type="checkbox"/>	<input type="checkbox"/> <input type="checkbox"/> <input type="checkbox"/> <input type="checkbox"/>	17.0#
		42"	30"	12"	TXPVF180/3042	<input type="checkbox"/>	<input type="checkbox"/> <input type="checkbox"/> <input type="checkbox"/> <input type="checkbox"/>	13.0#
	• Upholstered	54"	30"	24"	TXPVF180/3054	<input type="checkbox"/>	<input type="checkbox"/> <input type="checkbox"/> <input type="checkbox"/> <input type="checkbox"/>	16.0#
	• 180° top cap	66"	30"	36"	TXPVF180/3066	<input type="checkbox"/>	<input type="checkbox"/> <input type="checkbox"/> <input type="checkbox"/> <input type="checkbox"/>	19.0#
	• Two pieces of fabric wrapped universal height change trim	84"	30"	54"	TXPVF180/3084	<input type="checkbox"/>	<input type="checkbox"/> <input type="checkbox"/> <input type="checkbox"/> <input type="checkbox"/>	23.0#
	• Light block	66"	42"	24"	TXPVF180/4266	<input type="checkbox"/>	<input type="checkbox"/> <input type="checkbox"/> <input type="checkbox"/> <input type="checkbox"/>	20.0#
	• Two half-posts (height A)	84"	42"	42"	TXPVF180/4284	<input type="checkbox"/>	<input type="checkbox"/> <input type="checkbox"/> <input type="checkbox"/> <input type="checkbox"/>	25.0#
	• Two half-posts (height B)	66"	54"	12"	TXPVF180/5466	<input type="checkbox"/>	<input type="checkbox"/> <input type="checkbox"/> <input type="checkbox"/> <input type="checkbox"/>	21.0#
	• Four sets of half post base tile hooks	84"	54"	30"	TXPVF180/5484	<input type="checkbox"/>	<input type="checkbox"/> <input type="checkbox"/> <input type="checkbox"/> <input type="checkbox"/>	26.0#
	• Connecting hardware	84"	66"	18"	TXPVF180/6684	<input type="checkbox"/>	<input type="checkbox"/> <input type="checkbox"/> <input type="checkbox"/> <input type="checkbox"/>	27.0#
• SX Starlight Silver finish is only offered on flat aluminum trim								

A **B** **C**

HOW TO ORDER

Indicate the following information on order form:

- Quantity of each item.
- Model number, including options. See "How To Build a Model Number".
- Any special service required.

Note: • The indicates that a choice is required.
 • The absence of the indicates that no choice is required.
 • Alpha-numeric characters in place of indicate that no other alternatives are available.

HOW TO BUILD A MODEL NUMBER

- A** Select basic model.
- B** Select trim color.
Refer to the **Product Color Options** page in this catalog.
SX Starlight Silver finish is only offered on flat aluminum trim.
- C** Select fabric color.

Tech Preconfigured Intersection Conditions

Tech Panel Components

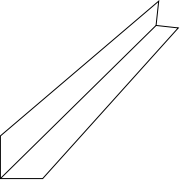
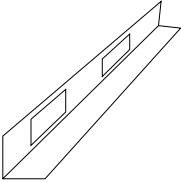
	MODEL	W	MODEL NUMBER		Approx. Packaged Weight
			Basic Model	Trim Color	
	Single Side Base Raceway-No Grommet Holes	12"	46.1220.12	<input type="checkbox"/>	1.0#
	<ul style="list-style-type: none"> Allows Tech Panel on one side of panel and access to power/data cables on opposite side Solid bottom and hinged door SX Starlight Silver finish is only offered on flat aluminum trim 	18"	46.1220.18	<input type="checkbox"/>	1.0#
		24"	46.1220.24	<input type="checkbox"/>	1.0#
		30"	46.1220.30	<input type="checkbox"/>	2.0#
		36"	46.1220.36	<input type="checkbox"/>	3.0#
		42"	46.1220.42	<input type="checkbox"/>	3.0#
		48"	46.1220.48	<input type="checkbox"/>	3.0#
		54"	46.1220.54	<input type="checkbox"/>	3.0#
HRDPT	60"	46.1220.60	<input type="checkbox"/>	4.0#	
	Single Side Raceway w/Grommet Holes	24"	46.1215.24	<input type="checkbox"/>	1.0#
	<ul style="list-style-type: none"> Allows Tech Panel on one side of panel and access power/data receptacles on opposite side Solid bottom and hinged door 12" and 18" not available with grommet holes 24" available with one grommet hole Each hole includes a standard filler plate Grommets ordered separately (included with duplex receptacles) SX Starlight Silver finish is only offered on flat aluminum trim 	30"	46.1215.30	<input type="checkbox"/>	2.0#
		36"	46.1215.36	<input type="checkbox"/>	2.0#
		42"	46.1215.42	<input type="checkbox"/>	3.0#
		48"	46.1215.48	<input type="checkbox"/>	3.0#
		54"	46.1215.54	<input type="checkbox"/>	3.0#
		60"	46.1215.60	<input type="checkbox"/>	4.0#
		HRDPT			

A

B

HOW TO ORDER

Indicate the following information on order form:

- Quantity of each item.
- Model number, including options. See "How To Build a Model Number".
- Any special service required.

Note: • The indicates that a choice is required.

- The absence of the indicates that no choice is required.
- Alpha-numeric characters in place of indicate that no other alternatives are available.

HOW TO BUILD A MODEL NUMBER

A Select basic model.

B Select trim color.
Refer to the **Product Color Options** page in this catalog.
SX Starlight Silver finish is only offered on flat aluminum trim.

HOW TO ORDER

Indicate the following information on order form:

1. Quantity of each item.
2. Model number, including options. See "How To Build a Model Number".
3. Any special service required.

Note:

- The indicates that a choice is required.
- The absence of the indicates that no choice is required.
- Alpha-numeric characters in place of indicate that no other alternatives are available.

Universal Electrical Connection Diagram

4-4-2

4-4-2		
Receptacles available	Wires to be used	Gauge of wire
Circuit 1	Black	12
	White/Black Letters	12
	Green or Bare	12
Circuit 2	Red	12
	White/Black Letters	12
	Green or Bare	12
Circuit 3	Blue	12
	White/Black Letters	12
	Green/Yellow Stripe or Gray	12
		12
Circuit 4	Pink	12
	White/Purple Letters	12
	Green/Yellow Stripe or Gray	12
		12

BLUE UL LABEL

4-4-2 Connection Diagrams

120/240V SINGLE PHASE

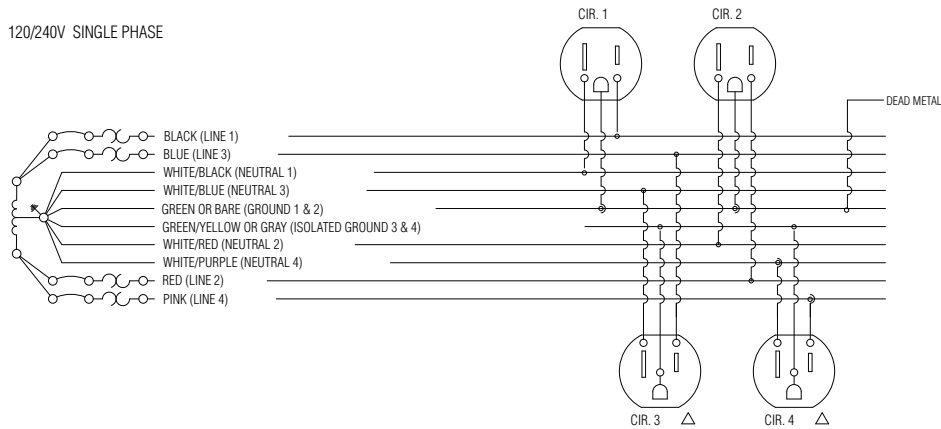

120/208V WYE (THREE PHASE)

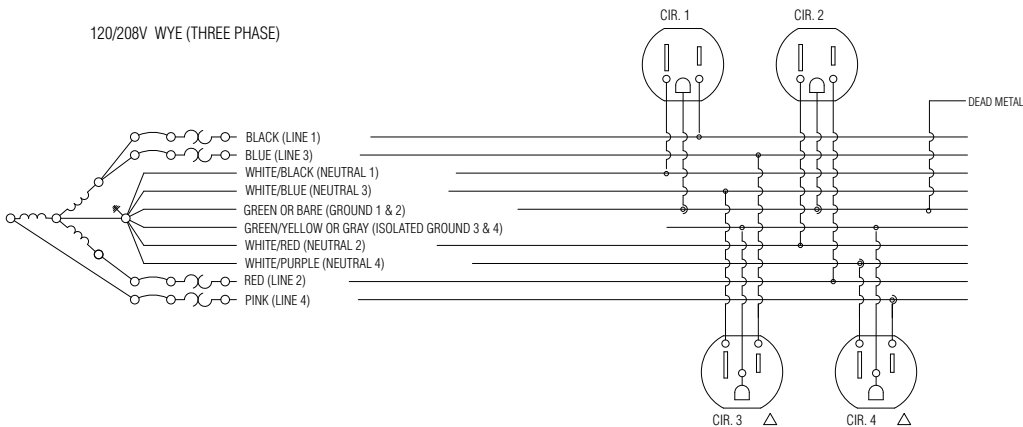

Universal Electrical Connection Diagram

6-2-2

6-2-2		
Receptacles available	Wires to be used	Gauge of wire
Circuit 1	Black White/Black Letters Green or Bare	12 10 12
Circuit 2	Red White/Black Letters Green or Bare	12 10 12
Circuit 3	Blue White/Black Letters Green or Bare	12 10 12
Circuit 4l	Pink White/Red Letters Green/Yellow Stripe or Gray	12 10 12
Circuit 5l	Tan White/Red Letters Green/Yellow Stripe or Gray	12 10 12
Circuit 6l	Orange White/Red Letters Green/Yellow Stripe or Gray	12 10 12

GREEN UL LABEL

6-2-2 Connection Diagrams

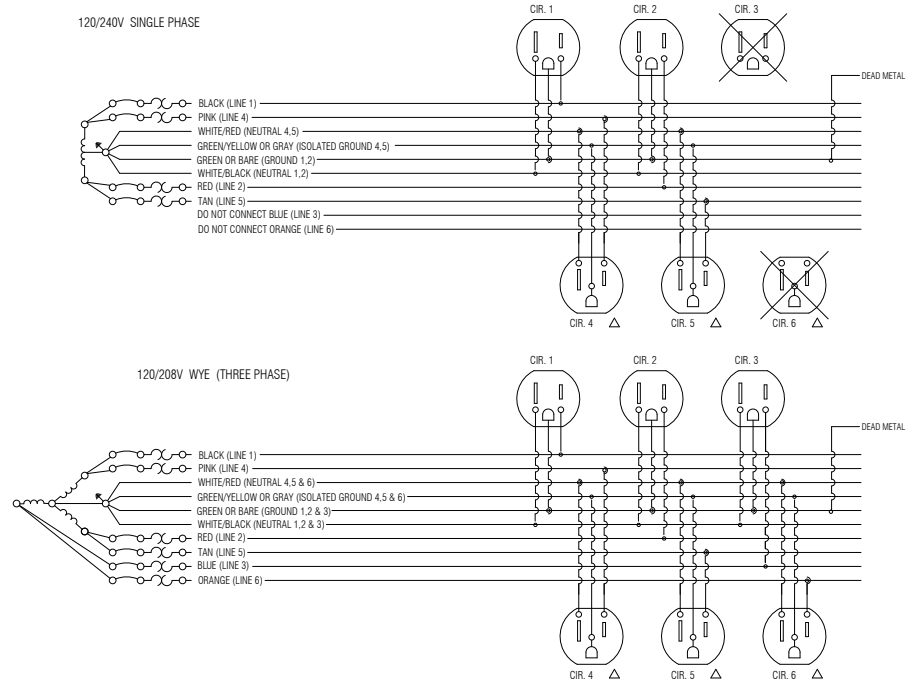

6-2-2 Connection Diagrams To An 8-Wire Building

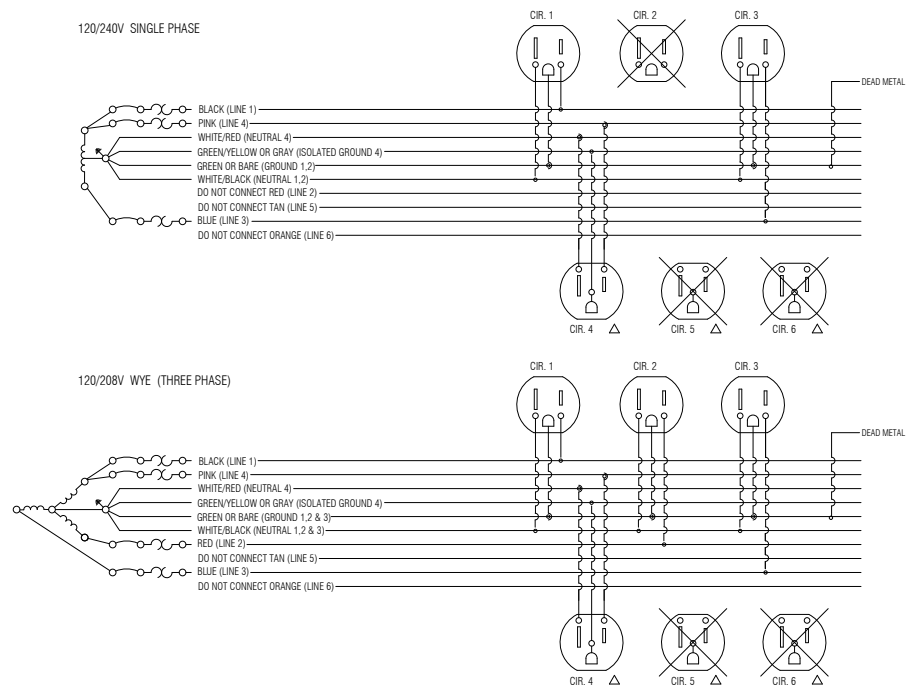

PowerWorks® C.O.M. Yardage Requirements

Tile Size	Actual Cut-Size	54" Non-Directional	54" Directional	66" Non-Directional	66" Directional	Tile Size	Actual Cut-Size	54" Non-Directional	54" Directional	66" Non-Directional	66" Directional
12 x 12	16 x 16	0.148	0.148	0.111	0.111	42 x 12	46 x 16	0.444	0.444	0.444	0.444
12 x 18	16 x 22	0.204	0.204	0.153	0.153	42 x 18	46 x 22	0.611	0.611	0.611	0.611
12 x 24	16 x 28	0.259	0.259	0.194	0.194	42 x 24	46 x 28	0.778	0.778	0.778	0.778
12 x 30	16 x 34	0.315	0.315	0.236	0.236	42 x 30	46 x 34	0.944	0.944	0.944	0.944
12 x 36	16 x 40	0.370	0.370	0.278	0.278	42 x 36	46 x 40	1.111	1.111	1.111	1.111
12 x 42	16 x 46	0.426	0.426	0.319	0.319	42 x 42	46 x 46	1.278	1.278	1.278	1.278
12 x 48	16 x 52	0.481	0.481	0.361	0.361	42 x 48	46 x 52	1.444	1.444	1.444	1.444
12 x 54	16 x 58	0.537	0.537	0.403	0.403	42 x 54	46 x 58	1.611	1.611	1.611	1.611
12 x 60	16 x 64	0.593	0.593	0.444	0.444	42 x 60	46 x 64	1.778	1.778	1.778	1.778
12 x 66	16 x 70	0.648	0.648	0.486	0.486	42 x 66	46 x 70	1.944	1.944	1.944	1.944
12 x 72	16 x 76	0.704	0.704	0.528	0.528	42 x 72	46 x 76	2.111	2.111	2.111	2.111
12 x 78	16 x 82	0.759	0.759	0.569	0.569	42 x 78	46 x 82	2.278	2.278	2.278	2.278
18 x 12	22 x 16	0.222	0.222	0.148	0.148	48 x 12	52 x 16	0.444	0.444	0.444	0.444
18 x 18	22 x 22	0.306	0.306	0.204	0.204	48 x 18	52 x 22	0.611	0.611	0.611	0.611
18 x 24	22 x 28	0.389	0.389	0.259	0.259	48 x 24	52 x 28	0.778	0.778	0.778	0.778
18 x 30	22 x 34	0.472	0.472	0.315	0.315	48 x 30	52 x 34	0.944	0.944	0.944	0.944
18 x 36	22 x 40	0.556	0.556	0.370	0.370	48 x 36	52 x 40	1.111	1.111	1.111	1.111
18 x 42	22 x 46	0.639	0.639	0.426	0.426	48 x 42	52 x 46	1.278	1.278	1.278	1.278
18 x 48	22 x 52	0.722	0.722	0.481	0.481	48 x 48	52 x 52	1.444	1.444	1.444	1.444
18 x 54	22 x 58	0.806	0.806	0.537	0.537	48 x 54	52 x 58	1.611	1.611	1.611	1.611
18 x 60	22 x 64	0.889	0.889	0.593	0.593	48 x 60	52 x 64	1.778	1.778	1.778	1.778
18 x 66	22 x 70	0.972	0.972	0.648	0.648	48 x 66	52 x 70	1.944	1.944	1.944	1.944
18 x 72	22 x 76	1.056	1.056	0.704	0.704	48 x 72	52 x 76	2.111	2.111	2.111	2.111
18 x 78	22 x 82	1.139	1.139	0.759	0.759	48 x 78	52 x 82	2.278	2.278	2.278	2.278
24 x 12	28 x 16	0.444	0.444	0.222	0.222	54 x 12	58 x 16			0.444	0.444
24 x 18	28 x 22	0.611	0.611	0.306	0.306	54 x 18	58 x 22			0.611	0.611
24 x 24	28 x 28	0.778	0.778	0.389	0.389	54 x 24	58 x 28			0.778	0.778
24 x 30	28 x 34	0.944	0.944	0.472	0.472	54 x 30	58 x 34			0.944	0.944
24 x 36	28 x 40	1.111	1.111	0.556	0.556	54 x 36	58 x 40			1.111	1.111
24 x 42	28 x 46	1.278	1.278	0.639	0.639	54 x 42	58 x 46			1.278	1.278
24 x 48	28 x 52	1.444	1.444	0.722	0.722	54 x 48	58 x 52			1.444	1.444
24 x 54	28 x 58	1.611	1.611	0.806	0.806	54 x 54	58 x 58			1.611	1.611
24 x 60	28 x 64	1.778	1.778	0.889	0.889	54 x 60	58 x 64			1.778	1.778
24 x 66	28 x 70	1.944	1.944	0.972	0.972	54 x 66	58 x 70			1.944	1.944
24 x 72	28 x 76	2.111	2.111	1.056	1.056	54 x 72	58 x 76			2.111	2.111
24 x 78	28 x 82	2.278	2.278	1.139	1.139	54 x 78	58 x 82			2.278	2.278
30 x 12	34 x 16	0.444	0.444	0.444	0.444	60 x 12	64 x 16			0.444	0.444
30 x 18	34 x 22	0.611	0.611	0.611	0.611	60 x 18	64 x 22			0.611	0.611
30 x 24	34 x 28	0.778	0.778	0.778	0.778	60 x 24	64 x 28			0.778	0.778
30 x 30	34 x 34	0.944	0.944	0.944	0.944	60 x 30	64 x 34			0.944	0.944
30 x 36	34 x 40	1.111	1.111	1.111	1.111	60 x 36	64 x 40			1.111	1.111
30 x 42	34 x 46	1.278	1.278	1.278	1.278	60 x 42	64 x 46			1.278	1.278
30 x 48	34 x 52	1.444	1.444	1.444	1.444	60 x 48	64 x 52			1.444	1.444
30 x 54	34 x 58	1.611	1.611	1.611	1.611	60 x 54	64 x 58			1.611	1.611
30 x 60	34 x 64	1.778	1.778	1.778	1.778	60 x 60	64 x 64			1.778	1.778
30 x 66	34 x 70	1.944	1.944	1.944	1.944	60 x 66	64 x 70			1.944	1.944
30 x 72	34 x 76	2.111	2.111	2.111	2.111	60 x 72	64 x 76			2.111	2.111
30 x 78	34 x 82	2.278	2.278	2.278	2.278	60 x 78	64 x 82			2.278	2.278
36 x 12	40 x 16	0.444	0.444	0.444	0.444	PRTU (Raceway Tiles)					
36 x 18	40 x 22	0.611	0.611	0.611	0.611	12 x 12	18 x 18	0.167	0.167	0.167	0.167
36 x 24	40 x 28	0.778	0.778	0.778	0.778	18 x 12	24 x 18	0.250	0.250	0.250	0.250
36 x 30	40 x 34	0.944	0.944	0.944	0.944	24 x 12	30 x 18	0.500	0.500	0.250	0.250
36 x 36	40 x 40	1.111	1.111	1.111	1.111	30 x 12	36 x 18	0.500	0.500	0.500	0.500
36 x 42	40 x 46	1.278	1.278	1.278	1.278	36 x 12	42 x 18	0.500	0.500	0.500	0.500
36 x 48	40 x 52	1.444	1.444	1.444	1.444	42 x 12	48 x 18	0.500	0.500	0.500	0.500
36 x 54	40 x 58	1.611	1.611	1.611	1.611	48 x 12	54 x 18	0.500	0.500	0.500	0.500
36 x 60	40 x 64	1.778	1.778	1.778	1.778	54 x 12	60 x 18			0.500	0.500
36 x 66	40 x 70	1.944	1.944	1.944	1.944	60 x 12	66 x 18			0.500	0.500
36 x 72	40 x 76	2.111	2.111	2.111	2.111						
36 x 78	40 x 82	2.278	2.278	2.278	2.278						

PowerWorks® C.O.M. Yardage Requirements

Tile Size	Actual Cut-Size	54" Non- Directional	54" Directional	66" Non- Directional	66" Directional
TB (Tackboards)					
24 x 12	30 x 18	0.500	0.500	0.250	0.250
30 x 12	36 x 18	0.500	0.500	0.500	0.500
36 x 12	42 x 18	0.500	0.500	0.500	0.500
42 x 12	48 x 18	0.500	0.500	0.500	0.500
48 x 12	54 x 18	0.500	0.500	0.500	0.500
54 x 12	60 x 18			0.500	0.500
60 x 12	66 x 18			0.500	0.500
24 x 16	30 x 22	0.611	0.611	0.306	0.306
30 x 16	36 x 22	0.611	0.611	0.611	0.611
36 x 16	42 x 22	0.611	0.611	0.611	0.611
42 x 16	48 x 22	0.611	0.611	0.611	0.611
48 x 16	54 x 22	0.611	0.611	0.611	0.611
54 x 16	60 x 22			0.611	0.611
60 x 16	66 x 22			0.611	0.611
24 x 30	30 x 36	1.000	1.000	0.500	0.500
30 x 30	36 x 36	1.000	1.000	1.000	1.000
36 x 30	42 x 36	1.000	1.000	1.000	1.000
42 x 30	48 x 36	1.000	1.000	1.000	1.000
48 x 30	54 x 36	1.000	1.000	1.000	1.000
54 x 30	60 x 36			1.000	1.000
60 x 30	66 x 36			1.000	1.000
24 x 48	30 x 54	1.500	1.500	0.750	0.750
30 x 48	36 x 54	1.500	1.500	1.500	1.500
36 x 48	42 x 54	1.500	1.500	1.500	1.500
42 x 48	48 x 54	1.500	1.500	1.500	1.500
48 x 48	54 x 54	1.500	1.500	1.500	1.500
54 x 48	60 x 54			1.500	1.500
60 x 48	66 x 54			1.500	1.500
PRDF (Overhead Cabinet)					
24	30 x 22	0.611	0.611	0.306	0.306
30	36 x 22	0.611	0.611	0.611	0.611
36	42 x 22	0.611	0.611	0.611	0.611
42	48 x 22	0.611	0.611	0.611	0.611
48	54 x 22	0.611	0.611	0.611	0.611
54	60 x 22			0.611	0.611
60	66 x 22			0.611	0.611
UTHF (Universal Trim Height Change)					
6	6 x 8	0.025	0.025	0.020	0.020
12	6 x 14	0.043	0.043	0.035	0.035
18	6 x 20	0.062	0.062	0.051	0.051
24	6 x 26	0.080	0.080	0.066	0.066
30	6 x 32	0.099	0.099	0.081	0.081
36	6 x 38	0.117	0.117	0.096	0.096
42	6 x 44	0.136	0.136	0.111	0.111
48	6 x 50	0.154	0.154	0.126	0.126
54	6 x 56	0.173	0.173	0.141	0.141
UTFF (Universal Trim Full Height)					
12	6 x 14	0.043	0.043	0.035	0.035
18	6 x 20	0.062	0.062	0.051	0.051
24	6 x 26	0.080	0.080	0.066	0.066
30	6 x 32	0.099	0.099	0.081	0.081
36	6 x 38	0.117	0.117	0.096	0.096
42	6 x 44	0.136	0.136	0.111	0.111
48	6 x 50	0.154	0.154	0.126	0.126
54	6 x 56	0.173	0.173	0.141	0.141
60	6 x 62	0.191	0.191	0.157	0.157
72	6 x 74	0.228	0.228	0.187	0.187

