

SYSTEM XXI®

PANEL
SYSTEMS
FURNITURE

installation instructions: BOOK 1



Table of Contents

Preinstallation of Panels	2
Recommended Tools	2
Before You Begin	2
Suggested Installation Sequence	3
Panel Terminology	3
Installation	3
Cable Management	4
Cables Through Top & Side of Panel	4
Panel-To-Panel Attachment	5
90° Panel Junction	6
Three-Way Panel Junction	7
End-of-Run, Top Cap & Raceway Covers	8
End-of-Run Assembly	8
Top Cap Installation	8
Raceway Cover Attachment	8
Two-Way Panel Junction & Four-Way Panel Junction	9
Two-Way Panel Junction	9
Four-Way Panel Junction	9
Two Height Panel Junction	10
Two Height Panel-to-Panel Connections	10
90° Assembly Instructions	10
180° Assembly Instructions	10
Curved Panel	11
Top Cap Installation	11
Raceway Cover Installation	11
Wall Mounts	12
Panel Center Mount	13
Panel Doors	14
Panel Door Thresholds	15
ERP Panels	16
ERP (Extended Raceway Panel) Panels	16
180° Panel Connection	16
90° Panel Connections (2, 3, or 4 Panel Intersections)	16
Stackable Panel Sections & Stackable Panel Trim	17
Attachment Bracket Assembly	17
Stackable Return Panels	18
Installation of Stackable Panel Trim	18
General Electrical Information	20
Ceiling Distribution	20
Floor Distribution	20
Identification of Parts	21
Suggested Electrical Installation Sequence	22
Panel-to-Panel Electrical Connections — Universal	23
Receptacle Installation	24
Base Power Infeed Harness Installation	25
Top Power Infeed Harness/Power Pole Installation	26
Universal Wire Connection Diagrams	27
6-2-2 Connection Diagrams	27
6-2-2 to 8-Wire Building	27
Connection Diagrams	28
4-4-2 Connection Diagrams	28

System XXI

Installation Instructions

PREINSTALLATION OF PANELS

Recommended Tools

Safety Glasses	Torx Driver (T-25)
Steel Tape Rule	Rubber Mallet
Level	Ball Peen Hammer
Utility Knife	Allen Wrench ($\frac{3}{16}$ ")
Hacksaw	Chalk Line
Electric Screwdriver	Glide Wrench ($\frac{7}{16}$ " open end)
Phillips Head Screw Bits (#2 & #4)	Flat Pry Bar
Straight Slotted Screwdriver	

Before You Begin

To simplify the installation of the panels, the following recommendations should be considered:

1. Stage the order by panel size, height, power, and color. Sort the cartons by top caps, raceway cover, and hinges. Then sort by size and color.
2. Make sure the area is clear and ready for panel installation.
3. Verify all room dimensions vs. the installation print. Measure power infeed locations to insure proper relation to panels. If using top feed power, route the top feed harnesses through the specified panel ends before assembling the workstations.
4. Use masking tape or a white chalk line to create a plot on the floor where the panel will be installed. Chalk line may be snapped to right, left, or center of panel. (Alternative is to fasten a string to both end panels, pull tight, then line up all panels in between.)
5. Review the panel terminology drawings before starting.
6. Mount carpet grippers with a ball peen hammer (to prevent damage to gripper) and turn all glides out $\frac{3}{8}$ ". This should be done after panels are taken from stack for setting in place. (A carpet gripper must be installed on a carpeted floor since it provides a non-sliding "connection" between panel and floor.)

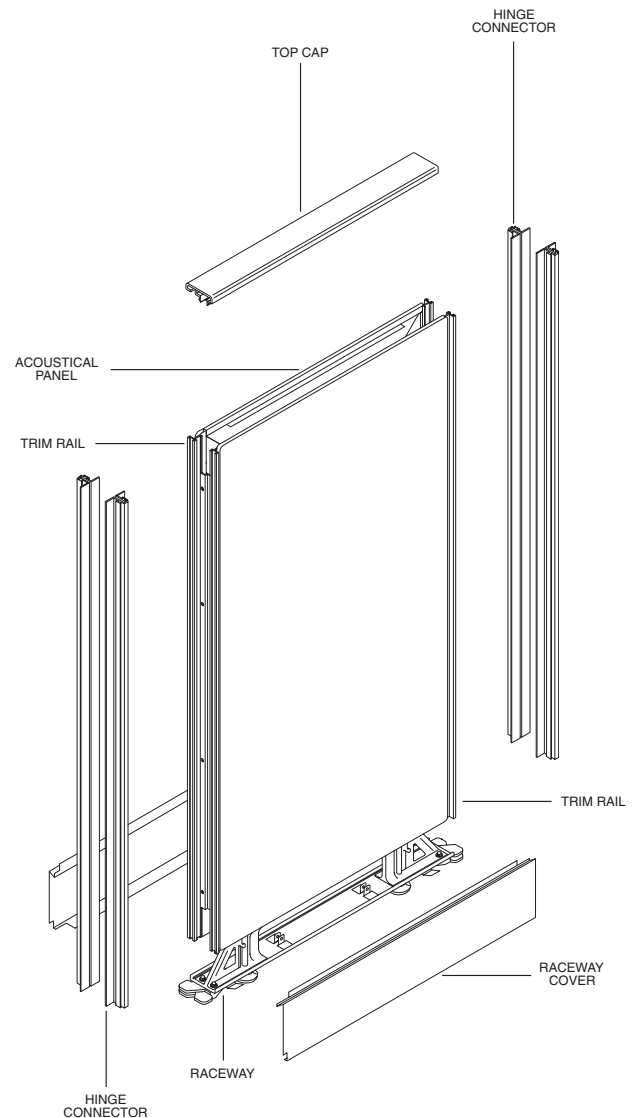

PANEL TERMINOLOGY

Installation Instructions

SUGGESTED INSTALLATION SEQUENCE

Panel Terminology

Each panel assembly includes (2) hinge connectors, (1) top cap, and (2) raceway covers.

Panel-to-panel jumpers are needed if panels are electrified.

Installation

Review the panel layout drawing to determine if there are any wall mount conditions. If there are, this is a good place to start. If not, you will want to start where panels come together at a 90° corner. If there are any "T" mount conditions, you will want to make them before attaching to adjacent panel with hinges (See 90° and "T" mount attachment).

1. Start panels in corners and three-way situations.

Note: Install raceway covers on the back side of panels that will be against walls (and inaccessible later). See page 8.

2. While installing, be sure to set the center of the panel directly over the center of the chalk line to assure straight panel runs (or directly over the left or right hand mark if you are using this option).

3. Leveling should be done as each panel is assembled. Level each panel before adjoining the next. (Having the glides already turned out $\frac{3}{8}$ " will help with the leveling at this point in case the floor is uneven.)

4. Once panels are completed, the next step should be to install the rigid electrical connections and receptacles. See page 20.

5. Installation of top feeds and power poles can now be accomplished. As stated on page 2, step 3, when installing top feeds, run the flexible conduit through the panel before the panel is installed.

6. Install overhead units or shelves where specified. Task lights can now be installed.

7. Install any System XXI accessories including worksurfaces (see Installation Book 2).

8. Install base feeds (as required).

9. Install exterior raceway covers.

System XXI

Installation Instructions

CABLE MANAGEMENT

Before finished ends, top caps or raceway covers are installed, you should consider where wires will be routed. Panels have wire management capabilities through top and base raceways as well as both side frames. Cables also may be laid in through the side frame at the end of a panel run before the end post assembly is installed.

Cables Through Top and Side of Panel

1. The top raceway of the panel can accommodate up to ten 25-pair telephone cables. These cables may be routed across the top raceway along a run of panels or they may be routed down the side frame to reach the base raceway or a worksurface height communications access door.
2. Cables with small connectors may be threaded down through the side frames without removing the trim rail. To route large connectors through the side frame, remove the trim rail.

Caution: If removing the trim rail, support both adjacent panels so they remain standing when the trim rail is released.

3. To remove the trim rail, lay the panel on edge and using a torx driver or Phillips driver (depending on the screw type), take out the screws connecting the trim rail to the frame. Tap up on the trim rail if necessary and it will slide off panel frame. To replace, repeat above steps in reverse order.

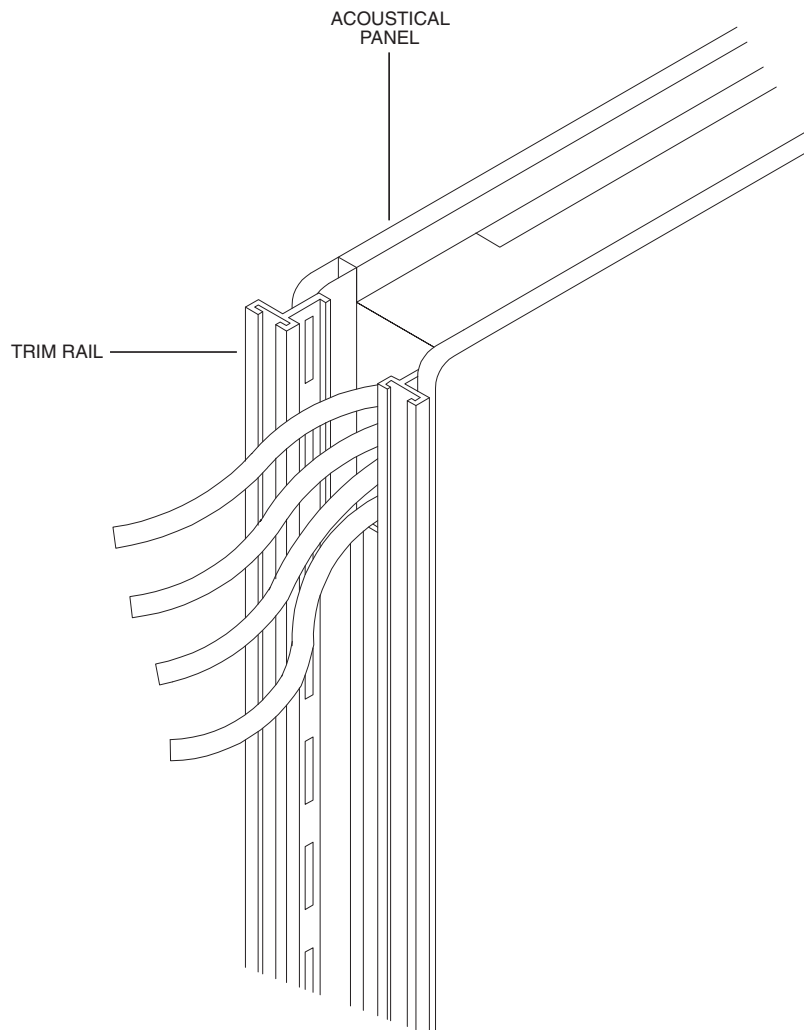

Installation Instructions

PANEL-TO-PANEL ATTACHMENT

1. To attach one panel to the next, bring the panels into position, making sure the interlocks are aligned (Figure 1). Slide the hinge connectors down the grooves provided, making sure the light shields are inside the panel (Figure 2).

2. Repeat the above steps until all panels are installed.

Level the panels as they are being installed by adjusting the glides at the bottom of the panel. All carpet grippers should be in place before this is done.

Caution: Refer to panel specification guidelines for limits on panel runs.

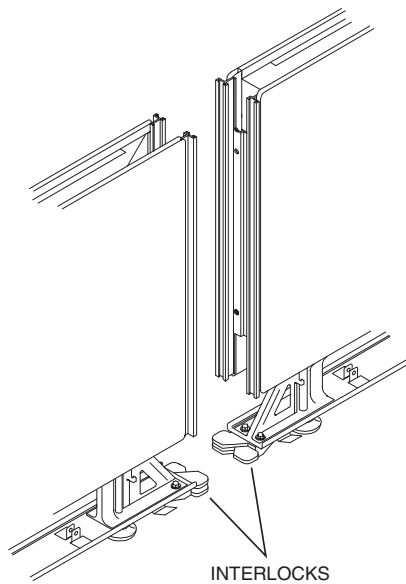

FIG. 1

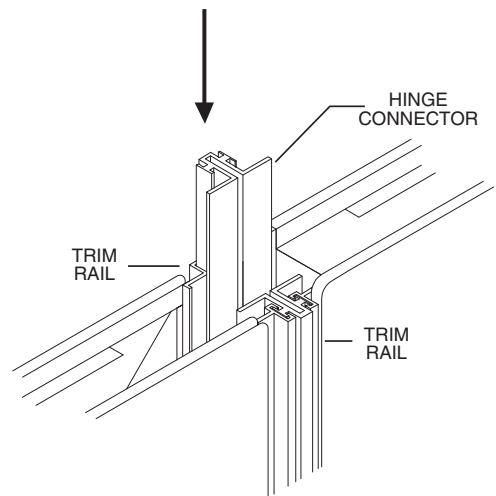

FIG. 2

System XXI

Installation Instructions

90° PANEL JUNCTION

1. When installing panels in a 90° junction, you may find it easier to line the panels up in a line (180°), slide in the hinge that forms the inside corner, then pivot the panel to the 90° position.

2. Position corner post and slide hinge connectors down grooves provided into the trim rail and corner post (Figure 1).

3. Once corner post is in place, the panel junction may be finished by locating the top cap corner piece on top of the corner post with sleeves inserted in adjoining top caps (Figure 2).

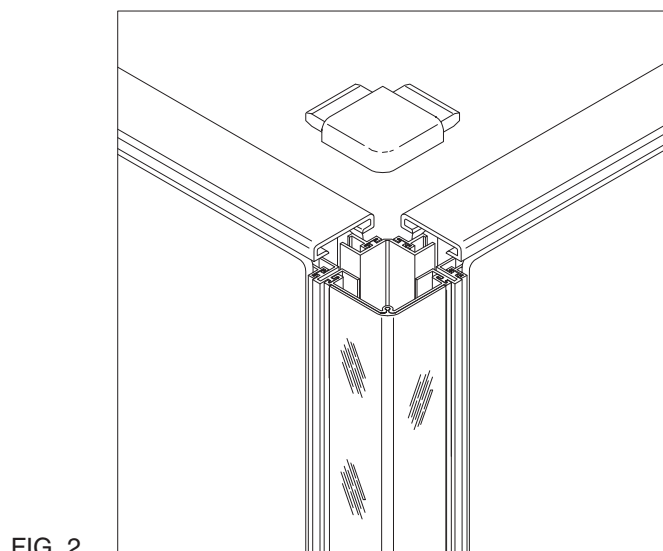
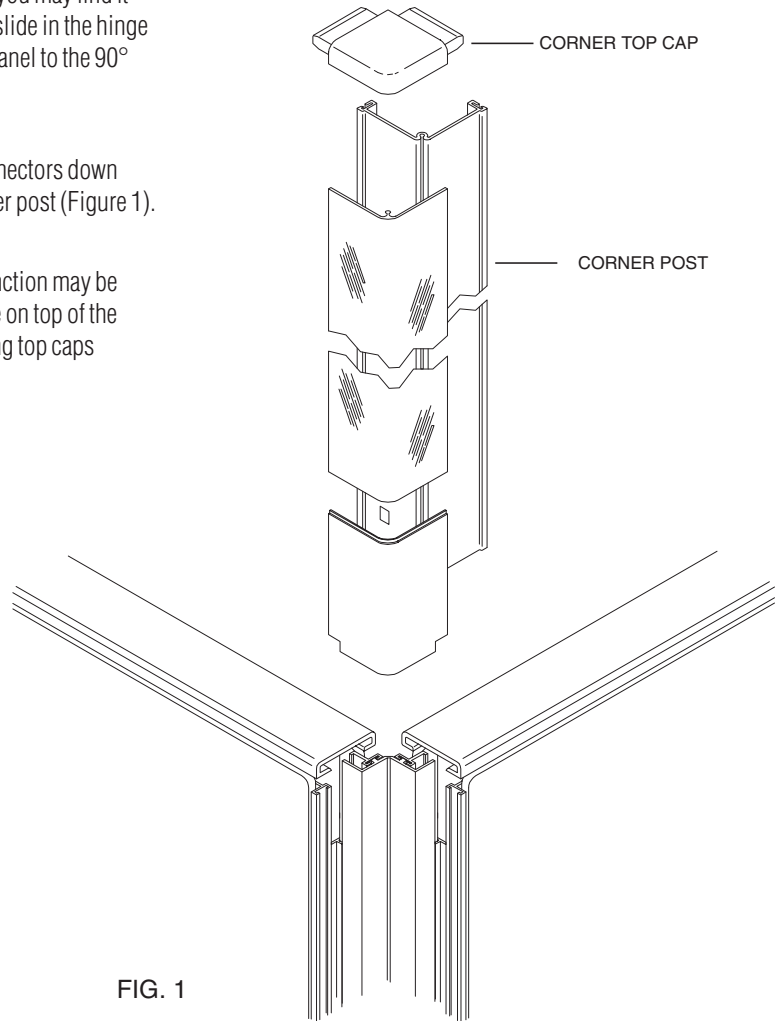

Installation Instructions

THREE-WAY PANEL JUNCTION

1. Position T-post and slide hinge connector down into grooves provided in the trim rail and T-post (Figure 1).
2. Once T-post is in place, position the T-post cap on top of the junction of the three panels, with all 3 top caps not snapped in place.
3. Push the sleeves of the T-post cap into the 3 top caps, and snap them in place (Figure 2).

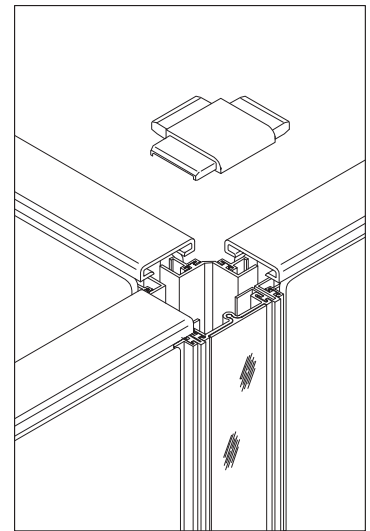
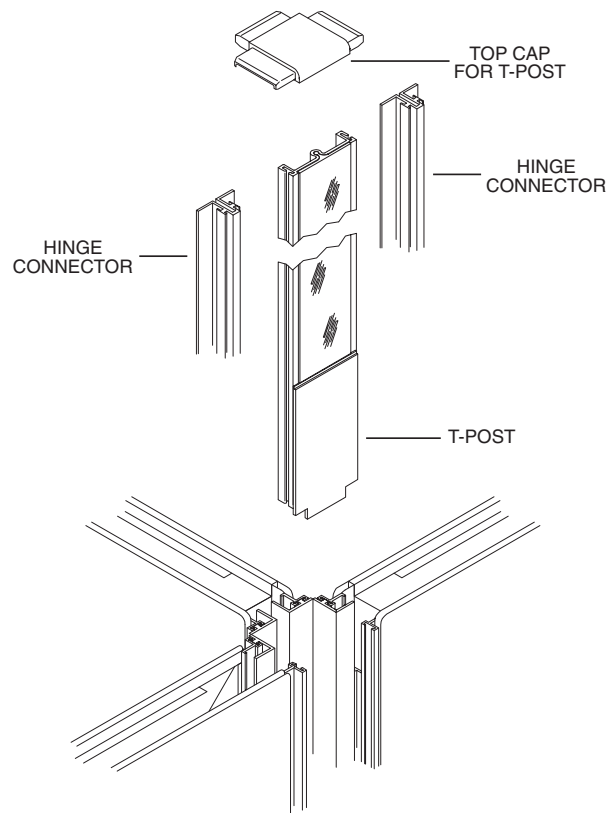

System XXI

Installation Instructions

END-OF-RUN, TOP CAP & RACEWAY COVERS

End-of-Run Assembly

1. An end-of-run trim is needed to finish a panel at the end of a panel run.
2. To attach the end-of-run trim, rest one end of the trim piece on the interlock at the base of the panel. Snap it into place on the trim rail of the panel (Figure 1).

Top Cap Installation

1. Once all panels are installed, you may install the top caps and end-of-run trim. Insert the end cap sleeve into the adjoining top cap. Insert the other end of the end cap sleeve into the end-of-run trim. Push straight down on one end of the top cap and work your way to the other end (Figure 2).
2. A top cap sleeve should be inserted into two adjacent top caps when they are in a 180° configuration.

Raceway Cover Attachment

1. With panels installed, panel-to-panel connectors in place, receptacles located, and all other wiring completed (see section two of this book), the last step is to install the raceway covers. Hook the appropriate length raceway cover into place on the tabs of the support housings. Swing the raceway cover down until the spring clips on the pan snap onto the notch provided (Figure 3).

Spring clips must be located WITHIN the raceway cover as shown.

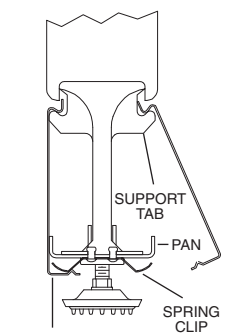
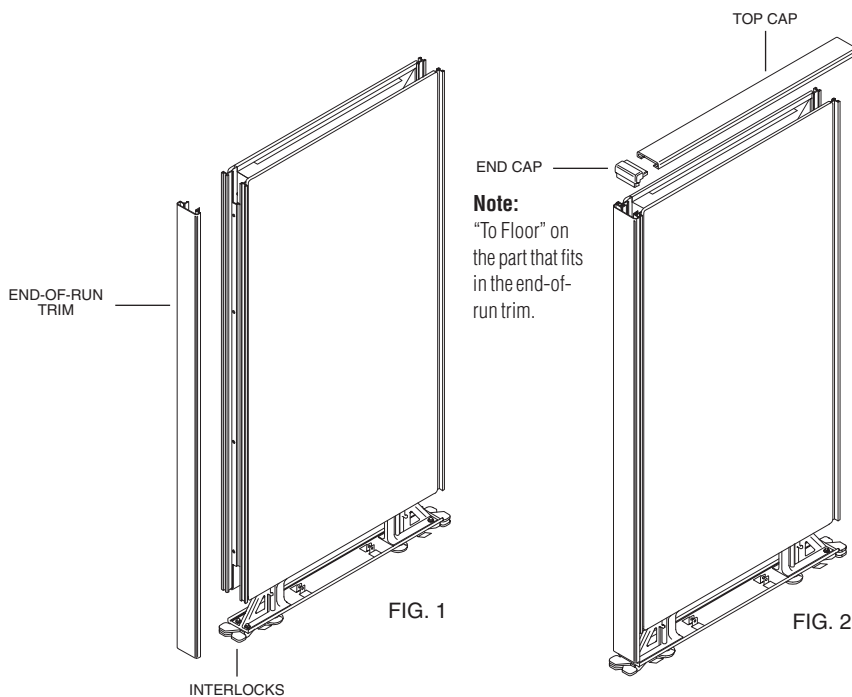

FIG. 3

Installation Instructions

TWO-WAY PANEL JUNCTION & FOUR-WAY PANEL JUNCTION

Two-Way Panel Junction

1. Position the two-way cap on top of the junction of two panels intersecting the junction of two lower panels, but with the two upper top caps not snapped in place.

2. Push the sleeves of the two-way cap into each of the two adjoining top caps, then snap the two top caps into place (Figure 1).

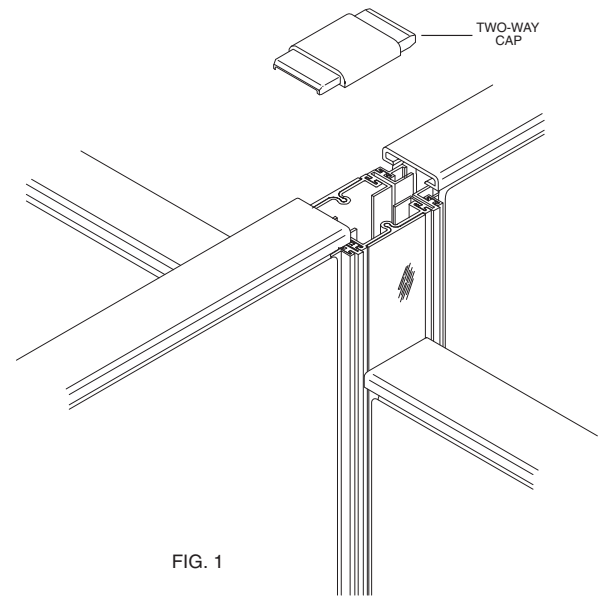

Four-Way Panel Junction

1. Position the four-way cap on top of the junction of the four panels, with all four top caps not snapped in place.

2. Push the sleeves of the four-way cap into each of the two adjoining top caps, then snap the four top caps into place (Figure 2).

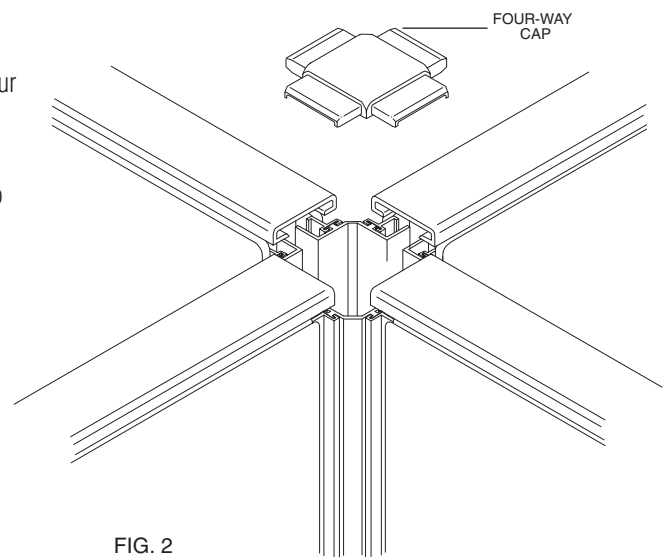

System XXI

Installation Instructions

TWO HEIGHT PANEL JUNCTION

Two Height Panel-to-Panel Connections

90° Assembly Instructions

1. Place the lower corner post in place (with hinge connectors), as described for a standard 90° corner.
2. Set corner post top cap in place.

Note: The top cap sleeve must be cut off one side of the corner post top cap in order for it to fit properly, and not interfere with the upper panel trim rail.

3. Slide the lower panel top cap onto the corner post top cap sleeve, then snap the top cap onto the lower panel.
4. Snap the variable height end-of-run trim into place. The end-of-run will sit on corner post top cap.
5. Put the upper panel top cap and end-of-run top in place (Figure 1).

180° Assembly Instructions

1. Put lower panel top cap in place as usual.
2. Snap end-of-run trim into place. End-of-run will sit on lower top cap.

When a countertop is placed on the lower panel, the end-of-run must be shortened to accommodate the countertop.

3. Put the upper panel top cap and end-of-run top cap in place (Figure 2).

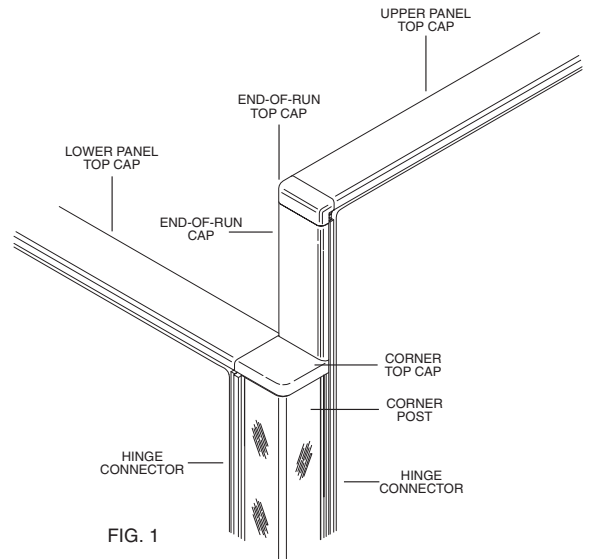

FIG. 1

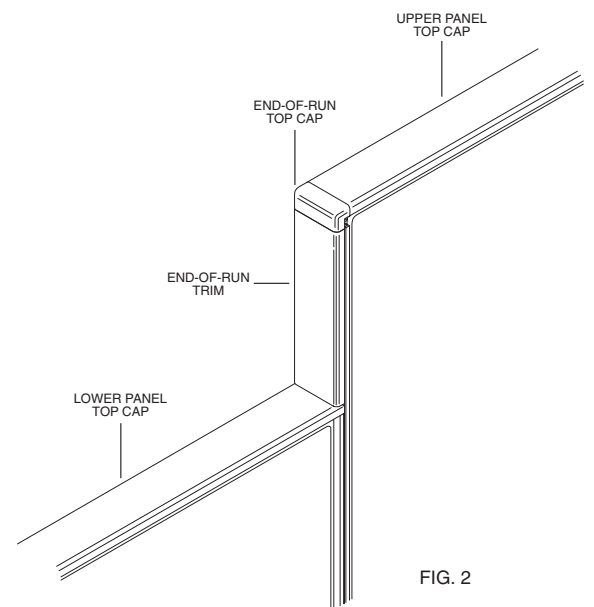

FIG. 2

Installation Instructions

CURVED PANEL

Curved Panel

A curved panel will come completely assembled except for the following items (Figure 1):

1. Raceway (inner/outer)
2. Top cap
3. Hinges

Top Cap Installation

1. To install the curved panel top cap, carefully slide a top cap sleeve into each end of the curved top cap, and into the adjoining top cap. Push straight down on the curved top cap to connect the dual-lock tabs (Figure 2).

Raceway Cover Installation

1. With panels installed and all wiring completed, the last step is to install the raceway covers. There are spring clips on the backside of the raceway covers. Push the raceway cover down until the spring clips snap onto the fingers provided (Figure 3).

Note: The inside raceway cover is shorter in length than the outside raceway cover.

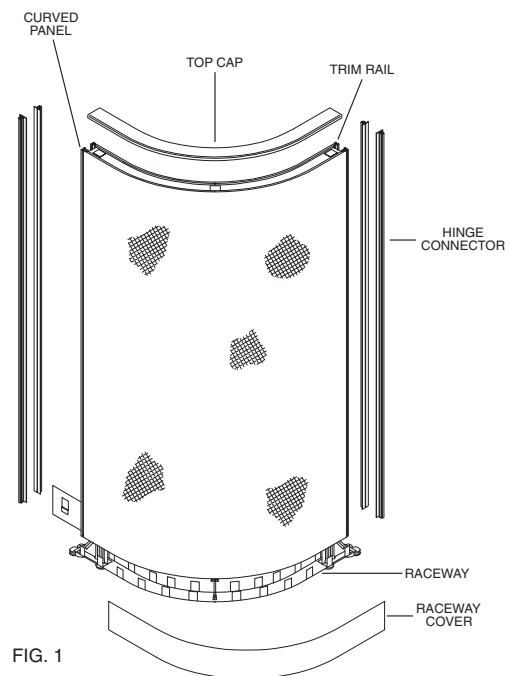

FIG. 1

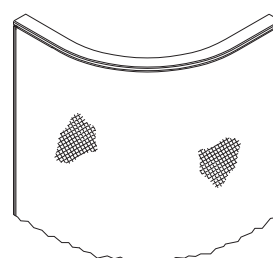

FIG. 2

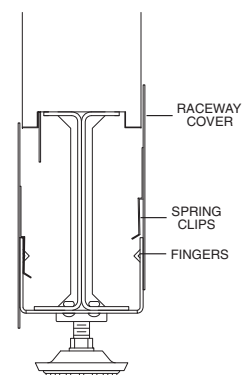

FIG. 3

System XXI

Installation Instructions

WALL MOUNTS

Note: Instructions are for an adjustable wall mount kit. In the standard wall mount kit you will not receive the "U" channel or the spacers, but the installation technique is the same.

Caution: Determine the type of wall construction. The wall mount extrusion must be mounted only to a structurally sound wall using the type of connector best suited for the wall. Mounting into studs is recommended.

1. Determine the desired location of the wall mount for the panel to be mounted to the wall.
2. Remove the panel interlock (take out interlock bolts) from the bottom of the panel which is to be butted against the wall (Figure 1). This requires the use of a $\frac{3}{8}$ " wrench.

Reinstall interlock bolts (which were holding the interlock in place) with two ($\frac{1}{4}$ -20) nuts provided in the wall mount kit. (This secures the black support housing in place.)

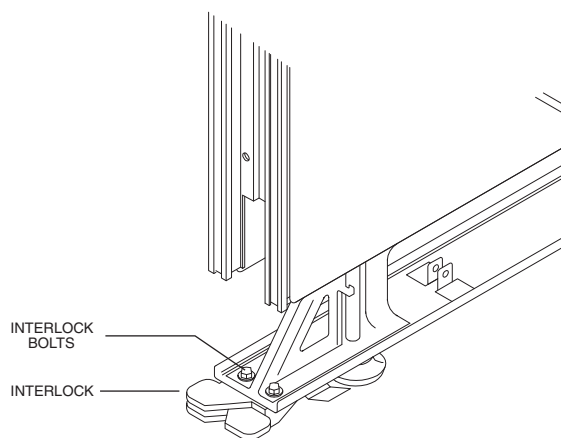

FIG. 1

3. To determine the proper mounting height, you must first level the panel to be attached to the wall mount. When level, move this panel against the wall and mark the wall at the top of the panel trim rail.

4. Using the steel "U" channel, hold it at the mark on the wall. Hold a level to this "U" channel and measure the difference at each mounting hole.

5. Stick the proper amount of $\frac{1}{8}$ " cork spacers to the "U-channel" at each hole (Figure 2) to fill any difference between the level and the "U" channel.

6. Attach the wall mount to the wall checking the level both vertically and horizontally.

7. The panel is now ready for attachment to the wall mount extrusion. This utilizes the same hinge connector attachment which joins all other panels (Figure 2). (You may trim off the light block portion of the hinge on the wall mount side to facilitate installation, if necessary.)

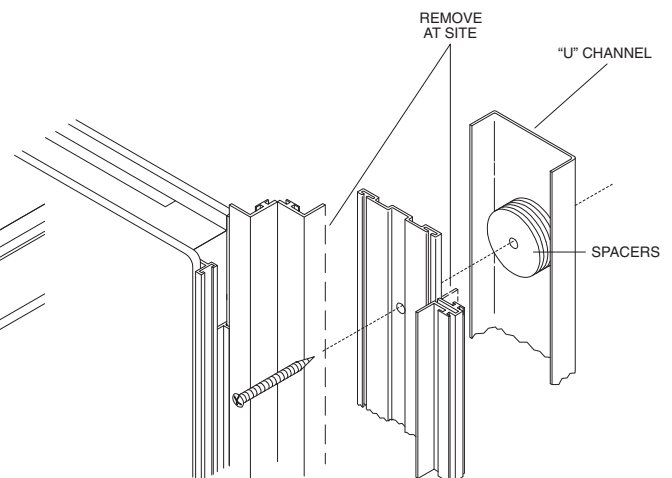

FIG. 2

Installation Instructions

PANEL CENTER MOUNT

Installation

1. Remove top caps from both panels (Figure 1).
2. Remove raceway covers from panel to be attached. Remove (1) interlock from the end you wish to attach to the other panel. Replace interlock with (2) $\frac{1}{4}$ " hex nuts provided in hardware kit.
3. Remove the raceway cover on the side of the panel where the panel is to be attached. Insert one of the aluminum clips into the welting groove at approximately the center of where the panel is to be attached (Figure 1). Replace the cover and the clip will stay in the groove (Figure 2).
4. Take the panel to be attached (the end with the interlock removed) and slide the threaded rod down the vertical frame member. Lift the panel to be attached and guide the clip up the frame with the threaded rod through the (2) holes in the clip (Figure 3).

Install flat washer, lockwasher and nut to the end of the threaded rod (Figure 3).

5. Adjust the panel being attached to the exact placement and install top clip, washer, lockwasher and nut (Figure 1).

6. Plumb panel, tighten nuts with deep $\frac{1}{2}$ " socket until snug, replace raceway covers and top caps.

Note: If panel or panels being attached with panel center mount are to be powered, then they must have their own power feed.

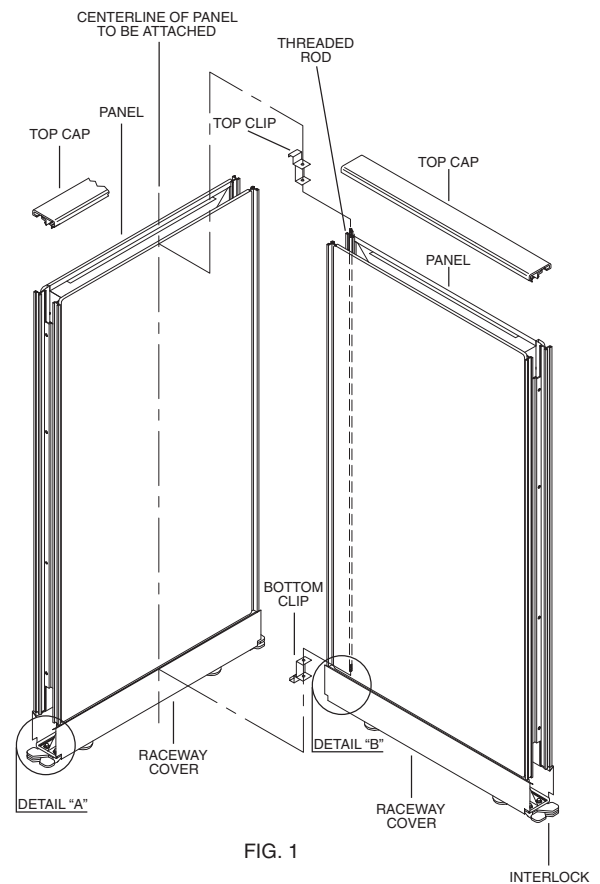

FIG. 1

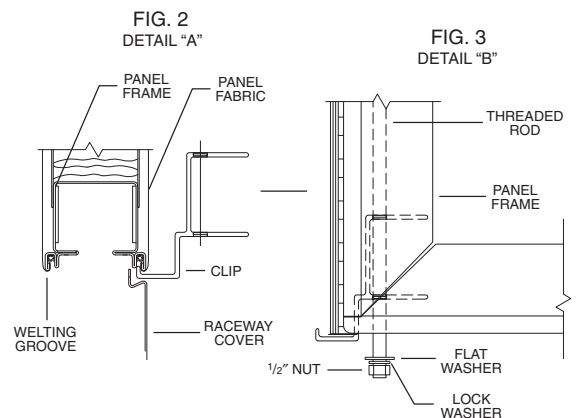

FIG. 2
DETAIL "A"

FIG. 3
DETAIL "B"

System XXI

Installation Instructions

PANEL DOORS

Tools Needed

- A. Torx (T-25) Tipped driver
- B. $\frac{3}{8}$ " Open End Wrench
- C. $\frac{7}{16}$ " Open End Wrench
- D. $\frac{1}{2}$ " Open End Wrench (If you are using a threshold)

Installation

1. Lay the door frame/door assembly flat on a clean surface, or on the cardboard carton it came in. Remove the (2) torx head screws from each side trimrail, and slide the trimrails about 12" toward the top of the door (Fig. 1).
 2. Attach an "L" shaped support bracket with the adjusting glide, at the bottom of each frame member. The "L" bracket mounts on the inner flange of the frame member using (4) $\frac{3}{8}$ " torx screws on each bracket (Fig. 2).
 3. Slide the two trimrails back in position and attach them to the frame with (12) $\frac{3}{8}$ " torx screws in each trimrail.
 4. Remove the interlock bolts from the panels adjacent to the door location using the $\frac{3}{8}$ " open end wrench. Set the interlocks aside and save the bolts for attaching the "L" brackets on the door frame to the adjacent panels.
- Note: If installing a door threshold, refer to instructions on page 15. If not, continue with step 5.**
5. Stand the panel door assembly in place between the adjacent panels (with interlocks removed) and adjust the door glides so the trimrails on the door and the panels match, and the "L" bracket on each side touch the bottom of the raceway pans on the adjacent panels. Secure the "L" brackets to the adjacent panel raceway pans, using the bolts you saved in step 4 and the nuts included in the hardware kit.
 6. Slide the vinyl hinges in to connect the door trimrails to the adjacent panel trimrails.
- Note: If the door is being installed at a 90° corner or T-configuration, you will need to attach the $1\frac{3}{4}$ " x $2\frac{3}{4}$ " flat plate with the 4 holes between the "L" bracket and the adjacent panel at a 90° angle.**

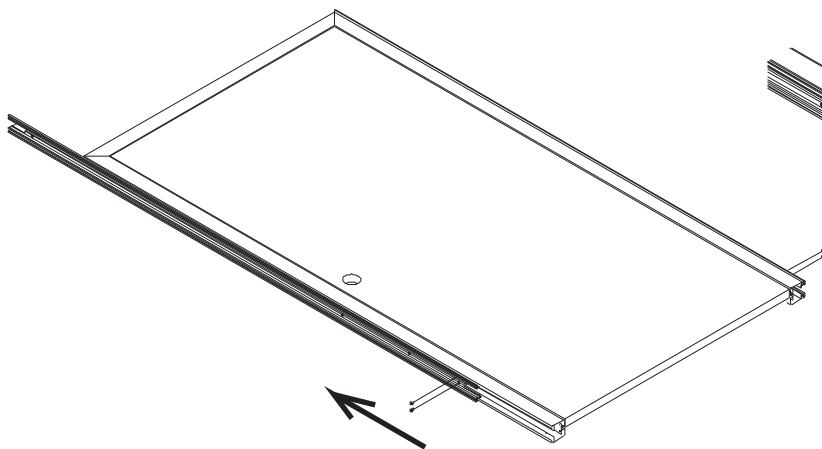

FIG. 1

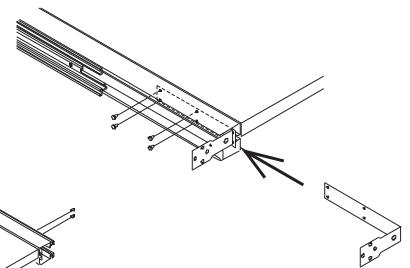

FIG. 2

Installation Instructions

PANEL DOOR THRESHOLDS

Installation

Note: Before starting the threshold installation, steps 1-4 on page 14 should be complete.

1. Remove a glide from an "L" bracket installed on the door frame.
2. Slide the glide through the hole in the threshold end clip. Turn the $\frac{5}{16}$ " nut down onto the glide stem until it is within $\frac{1}{8}$ " of the clip (Figure 1).
3. Repeat steps 1 and 2 on the other end of the threshold.
4. Screw the glides back into the "L" brackets on the door frame. Adjust the glide so the distance from the bottom of the glide to the top of the "L" bracket matches the distance from the bottom of the glide to the bottom of the raceway pan on the adjacent panel (Figure 2, DIM. A).

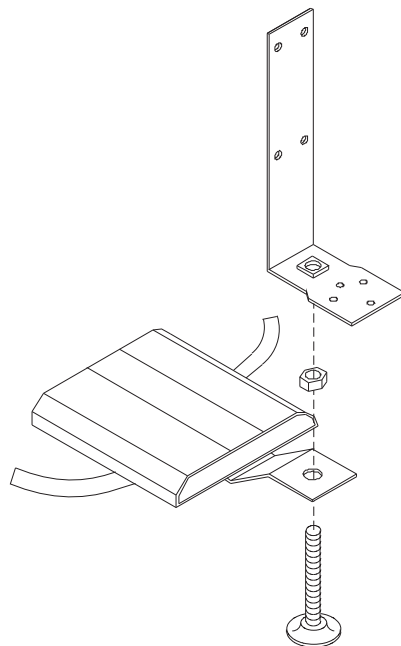

FIG. 1

5. While maintaining dim. A, tighten the nut down so it secures the threshold clip between the nut and the glide nut.
6. Peel back all four ends of the two double stick tape strips on the bottom of the threshold about 2". The tape covers will be peeled off as a final step to help adhere the threshold to the floor (Figure 1).
7. Refer back to steps 5 and 6 on page 14, to attach door in place. Once all final adjustments are made to the door, carefully pull the tape covers off the bottom of the threshold. You may need to lift up on the adjacent panels to pull the tape off.

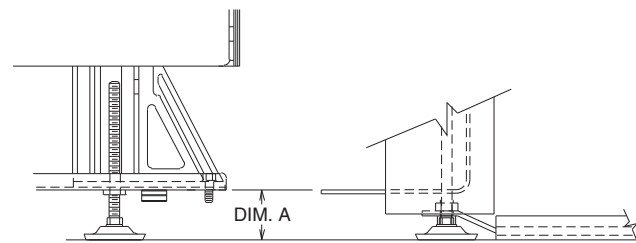

FIG. 2

System XXI

Installation Instructions

ERP PANELS

ERP (Extended Raceway Panel) Panels

Note: The installation of ERP panels, trim and electrical is identical to that of standard panels. The only additional installation step is the use of the septum bridges. See the steps below for the installation of the septum bridges.

180° Panel Connection

Note: Each ERP panel will include (1) 180° septum bridge.

1. Install ERP panels the same as the standard panels, but leave the raceway cover off one side of each panel.
2. Bend the 4 tabs down 90° on the steel 180° septum bridge (Figure 1).
3. Set the 180° septum bridge into the ends of the two steel septums in the ERP raceway of the adjacent panels. The 4 tabs bent down in step 2 will fit into the slots in the steel septums.
4. When the 180° septum bridge is lying flush with the surface of both steel septums, bend the tabs in under the steel septum to secure them in place.
5. Install the ERP raceway covers as usual.

90° Panel Connections (2, 3, or 4 panel intersections)

Note: Each ERP 90° trim includes (1) 90° steel septum bridge. Each ERP T-post trim includes (2) 90° steel septum bridges.

1. Install the ERP panels the same as the standard panels, but leave the raceway cover off one side of each panel.
2. Bend the 4 tabs down 90° on each end of the steel 90° steel septum bridges (Figure 1).
3. Set one 90° septum bridge into the ends of the two steel septums in the ERP raceways of two of the panels. If you are working with a 3 or 4 panel corner, place a second 90° septum bridge in position on the remaining panels so it overlaps the first bridge.
4. When the 90° septum bridge(s) is lying flush with the surface of the steel septums, bend the tabs in under the steel septum to secure them in place.
5. Install the ERP raceway covers as usual.

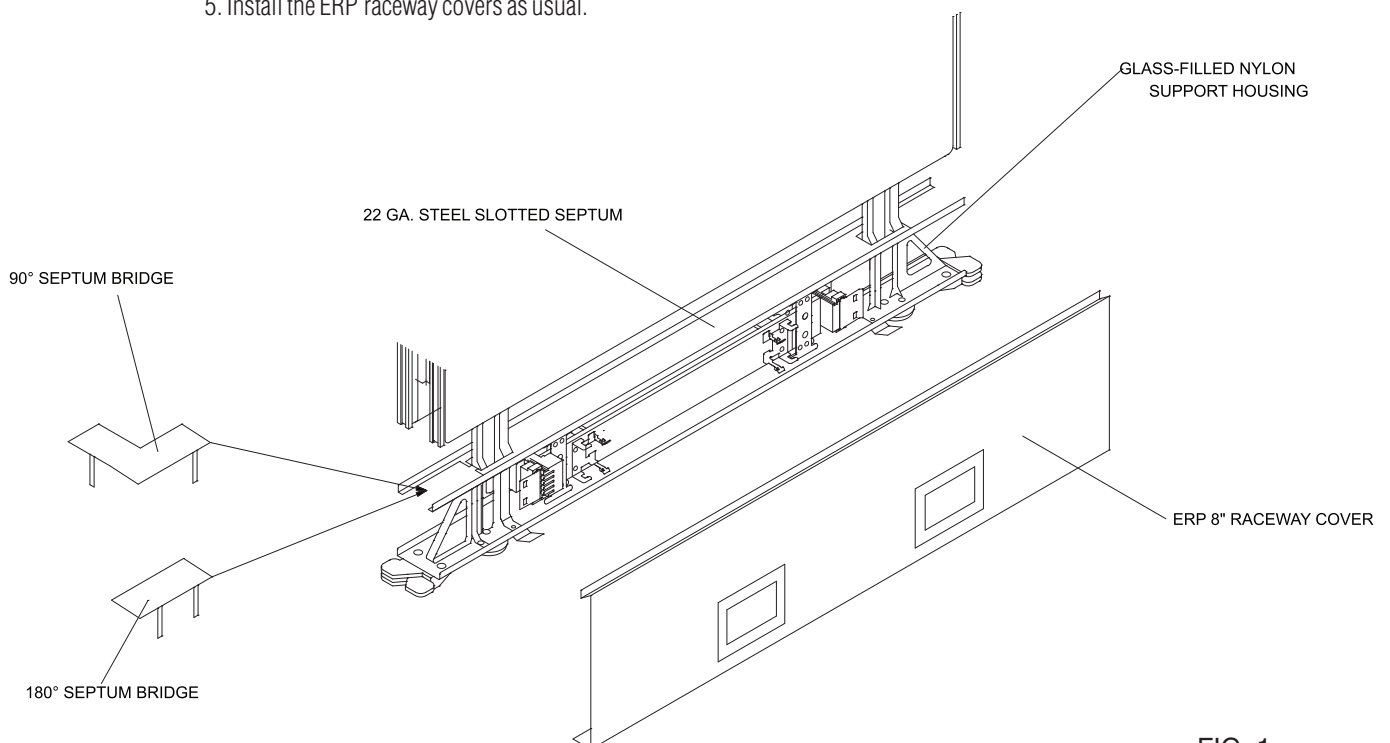

FIG. 1

Installation Instructions

STACKABLE PANEL SECTIONS & STACKABLE PANEL TRIM

Tools Required:

Phillips Screwdriver

Parts Included with Stackable Panel Section

- (1) Stackable Section
- (2) Stackable Attachment Brackets
- (5) 1/2" Phillips Screws
- (1) H-Shaped Spacer
- (2) Stackable Section Hinges

Attachment Bracket Assembly

1. Set the stackable panel section on its edge as illustrated to allow access to the lower end of the trimrail that does not have screws in it (Figure 1).

2. The attachment brackets will attach to the stackable panel section with two screws provided. Position the attachment bracket as shown and slide the bracket into the slotted trimrail at the "no screw" end (Figure 1).

3. Align the two mounting holes of the attachment bracket with the holes in the trimrail. Secure the attachment bracket to the trimrail with two 1/2" self tapping screws (Figure 2).

4. Carefully turn the stackable panel section over and attach the second attachment bracket to the other trimrail as described in the instructions above.

Note: It is recommended that two people complete the installation of each stackable panel section.

5. To install the stackable panel section, first remove the plastic top cap from the existing panel. Then place the H-spacer on top of the existing panel as shown (Figure 3).

6. Hold the stackable panel section over the existing panel so the 1/2" wide leg of each attachment bracket lines up directly over the 1/2" wide groove on the trimrails of the existing panel (Figure 3).

7. Carefully lower the stackable section down onto the existing panel until it is fully seated on the H-spacer (Figure 3). There will be about a 1/8" gap the entire width of the panel, and the hook on each bracket will catch the trimrail of the existing panel, when the stackable section is fully seated.

8. Slide the stackable hinges (not shown) into the trimrail of the stackable section and trimrail of the adjacent panels or other stackable sections if applicable.

9. Install any other stackable trim that may have been ordered separately.

(continued on next page)

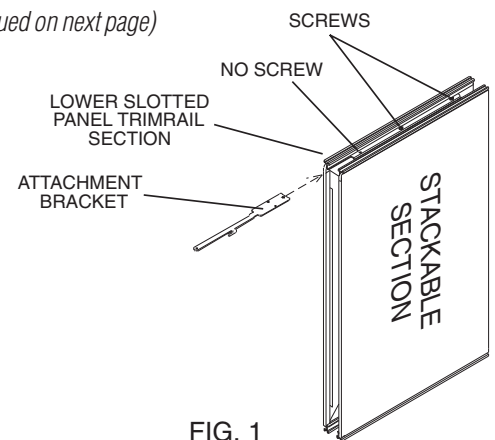

FIG. 1

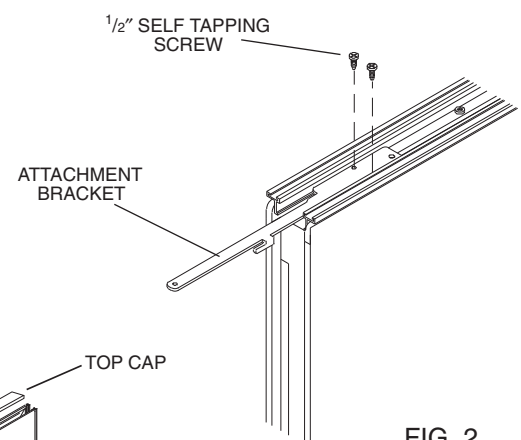

FIG. 2

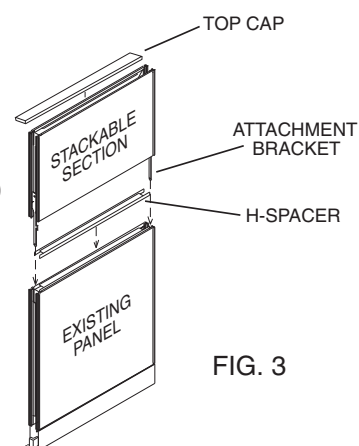

FIG. 3

System XXI

Installation Instructions

STACKABLE PANEL SECTIONS & STACKABLE PANEL TRIM (cont.)

10. Snap the top cap, from the existing panel, onto the stackable section (Figure 3).

Stackable Return Panels

11. When a stackable panel section is used as a return for a loaded stackable section, or a loaded standard panel, an additional $\frac{1}{2}$ " self tapping screw should be driven through the leg of the attachment bracket and into the full panel trimrail. Drill a $\frac{1}{8}$ " pilot hole into the trimrail of the full panel first, using the bracket leg as a guide (Figure 4).

Stackable Panel Trim

Installation of Stackable Panel Trim

Note: All of the stackable panel trim installs the same as standard panel trim. You do, however, have to specify the trim lengths that correspond to the stackable section height.

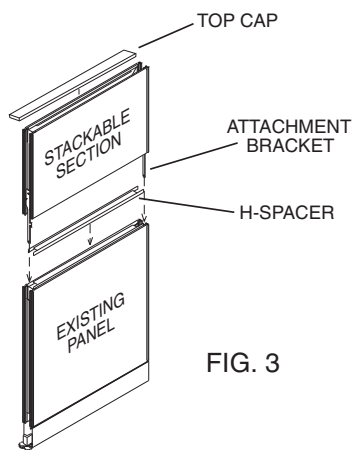

FIG. 3

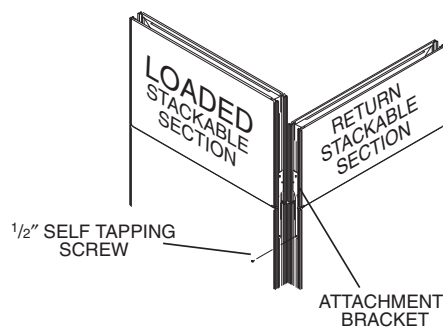

FIG. 4



System XXI

Electrical

GENERAL ELECTRICAL INFORMATION

General Electrical Information

Office furniture systems unite the day-to-day equipment with the services of the building.

1. Electrical power enters the panel system by one of two means: ceiling distribution (top fed) or floor distribution (base fed).

Ceiling Distribution

Ceiling distribution is one method of accessing the building's electrical and telecommunications. This method is accomplished by routing wires and cables through the ceiling, down the top feed power pole and into the panel.

Floor Distribution

Floor distribution is another method of tapping into the building's electrical and telecommunications system. This method can be accomplished several different ways. You will encounter a variety of situations that will require different solutions, depending if the building feed is in the floor or in the wall.

2. There are two types of 10 wire electrical systems available on System XXI panels, 622 and 442. Depending on the electrical system you choose, your building will need to supply the correct configuration of wires. See pages 27 and 28 for the connection diagrams for both wire systems.

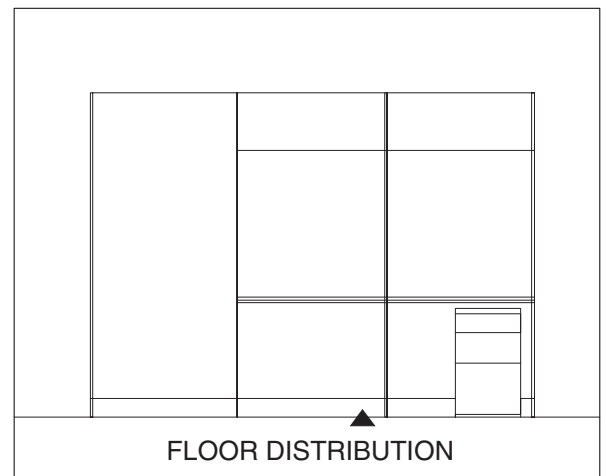
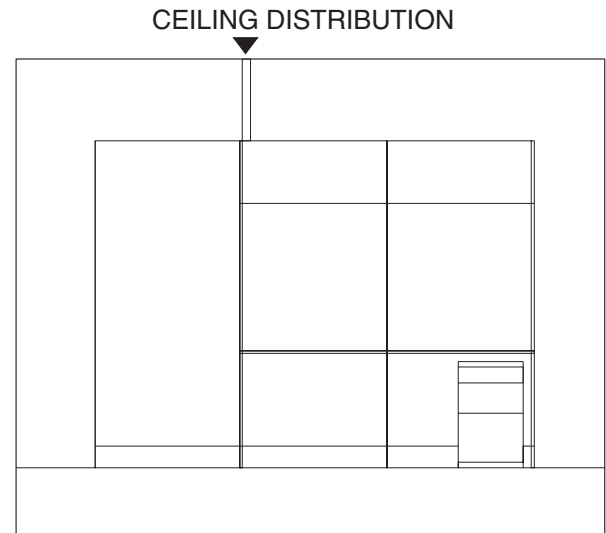

Electrical

IDENTIFICATION OF PARTS

1. Familiarize yourself with the common electrical parts before you begin your electrical installation.
2. To help you identify the three different types of electrical product, the UL labels that are on the electrical product are color coded as follows:
 - 8-wire: pink
 - Universal 10-wire 442: blue
 - Universal 10-wire 622: green
3. Conversion jumpers allow connections between the old electrical and the new universal 10-wire rigid wireways.

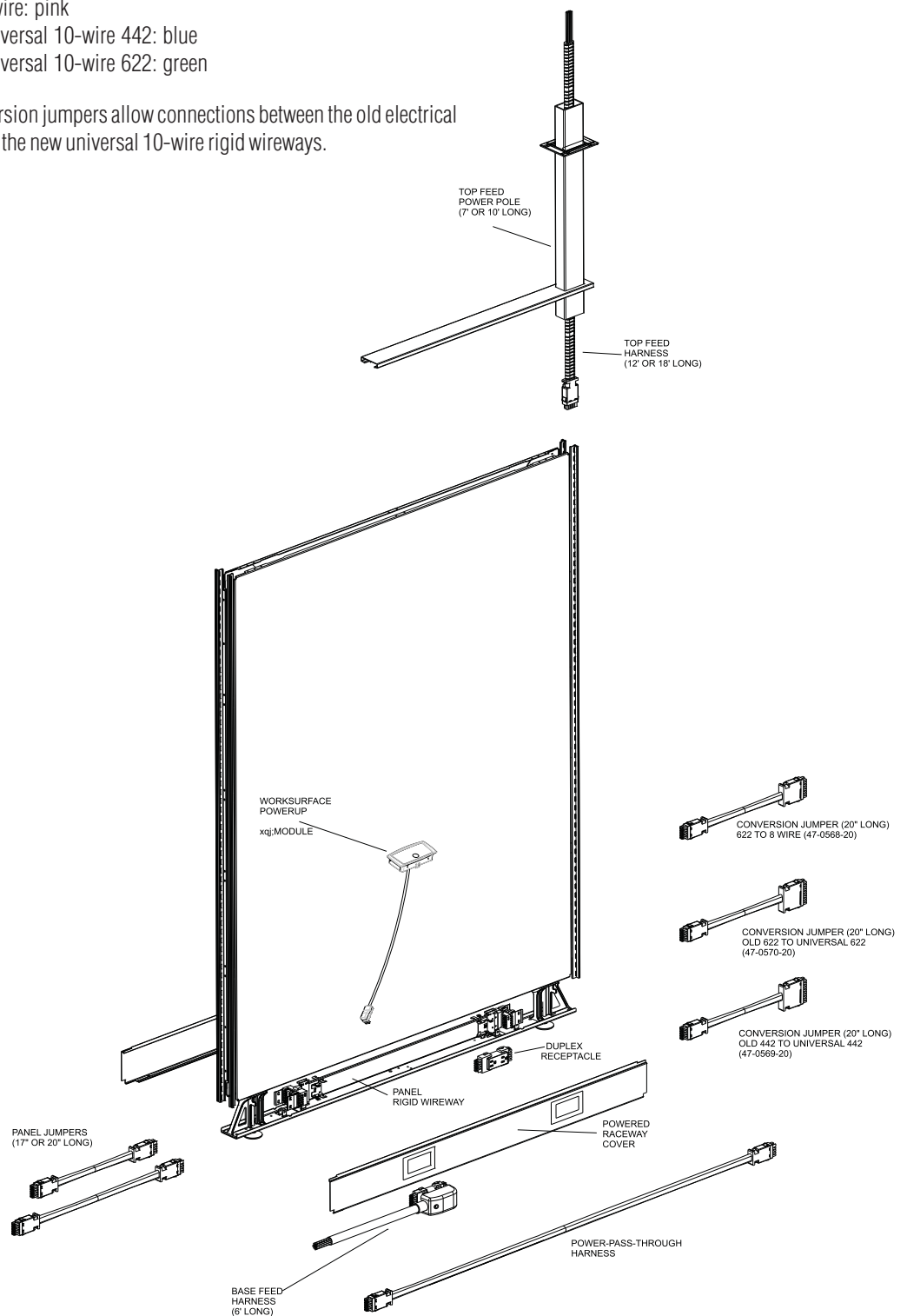

System XXI

Electrical

SUGGESTED ELECTRICAL INSTALLATION SEQUENCE

Before You Begin: Caution

- 1. Before installing electrical components, consult inspector or authorities for local codes. Connection to building power supply may be made ONLY after all panel wiring has been completed. Building connections must be made only by a licensed electrician following local codes in effect at the building site.**
- 2. Each circuit must be individually protected with a 120-volt, 20-amp circuit breaker device which will provide disconnect and overload protection.**

Installation Instructions

1. Familiarize yourself with the electrical parts and the locations of the top feeds or base feeds.
2. Install the top feed harness in the appropriate panel as the panels are being installed. (See page 2, item 3).
3. If base feed harnesses are to be located between a panel and a building wall, install the base feed harness as the panels are being installed. Leave access for the electrician to make the final hardwire connection of the base feed harness to the building.
4. Install all the Panel to Panel jumpers or the Power-Pass-Through harness as shown on the spaceplanning drawing. Be sure all connections are tight.
5. Install all receptacles in the locations shown on the spaceplanning drawing.
6. Check the electrical continuity at the furthest point from the power infeed location.
7. Install the panel raceway covers on the appropriate panels.

Electrical

PANEL-TO-PANEL ELECTRICAL CONNECTIONS UNIVERSAL

1. Power is carried between straight adjacent panels by panel jumpers. (See Figures A - H, for which jumper to use with different panel configurations.)
2. Attach the panel jumpers to the plug-in ports that are on the end of each panel wireway by pushing them together until they are locked.
3. If connecting a curved panel, or passing power through a non-powered panel, plug the correct length power-pass-through into the adjacent panel wireways (See Figures G - J).
4. Check the continuity from panel-to-panel with a voltmeter.

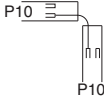
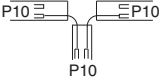
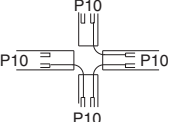
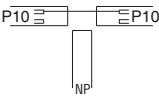
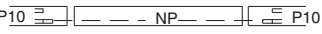
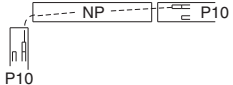
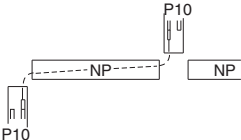
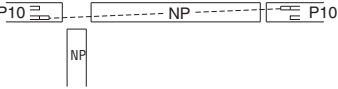
<p>A</p>  <p>YOU USE: (1) 18" PANEL JUMPER</p>	<p>B</p>  <p>YOU USE: (1) 18" PANEL JUMPER</p>
<p>C</p>  <p>YOU USE: (2) 18" PANEL JUMPERS</p>	<p>D</p>  <p>YOU USE: (3) 18" PANEL JUMPERS</p>
<p>E</p>  <p>YOU USE: (1) 20" PANEL JUMPER</p>	<p>F</p> <p>NOTE: YOU MUST SPECIFY EITHER THE 4-4-2 10-WIRE SYSTEM, OR THE 6-2-2 10-WIRE SYSTEM. THE TWO SYSTEMS CANNOT BE MIXED.</p>
<p>G</p>  <p>YOU USE: (1) POWER-PASS-THROUGH THE SAME SIZE AS THE NON-POWERED PANEL</p>	<p>H</p>  <p>YOU USE: (1) POWER-PASS-THROUGH THE SAME SIZE AS THE NON-POWERED PANEL</p>
<p>I</p>  <p>YOU USE: (1) POWER-PASS-THROUGH ONE SIZE LARGER THAN THE NON-POWERED PANEL, (WITH EXCEPTION OF 60" NP PANELS)</p>	<p>J</p>  <p>YOU USE: (1) POWER-PASS-THROUGH ONE SIZE LARGER THAN THE NON-POWERED PANEL, (WITH EXCEPTION OF 60" NP PANELS)</p>

System XXI

Electrical

RECEPTACLE INSTALLATION

Installing Receptacles

WARNING: Assembly of all mechanical frame components must be completed before making any electrical connections. All electrically connected furnishings must also be mechanically connected.

1. Position the receptacle on either end of the wireway as shown (depending on location desired), matching the (N) symbol to the same orientation on both the receptacle and wireway.
2. Align the receptacle so the end is in line with the inner socket on the wireway (Figure 1).
3. Push the receptacle back against the mounting plate (Figure 1).
4. Slide the receptacle to the side so the end terminals slide into the wireway inner socket (Figure 2).
5. Receptacle is properly seated when the catch clip on the wireway is between the wedges on the receptacle (Figure 3).

Removing Receptacle

1. Slightly lift the catch clips on the top and bottom of the receptacle (Figure 3) and slide the receptacle away from the socket on the wireway.
2. Pull the receptacle away from the wireway once the end of the receptacle clears the wireway socket.

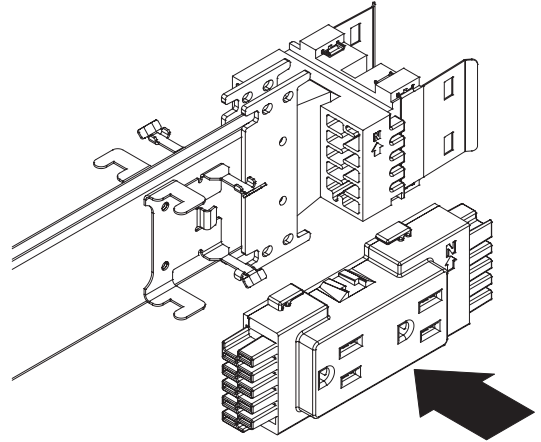

FIG. 1

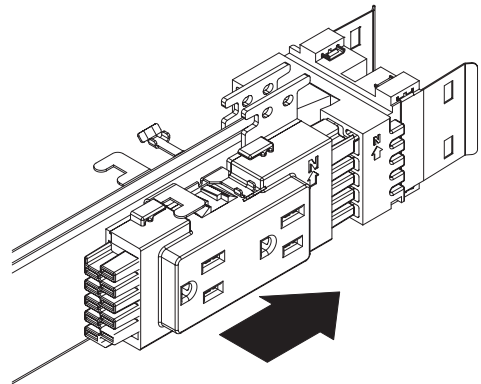

FIG. 2

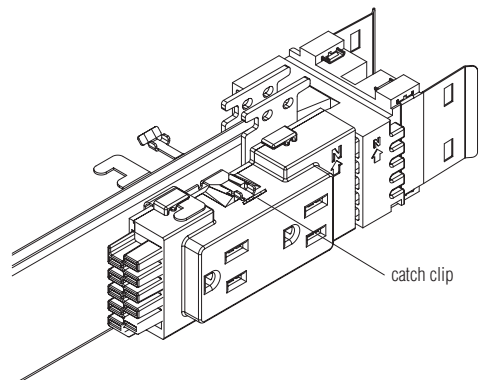

FIG. 3

Electrical

BASE POWER INFEEED HARNESS INSTALLATION

Base Power Infeed Installation

Caution: The wires in the end of the base feed power infeed must be hard-wired later by an electrician. It is not safe to perform the following steps if these wires are already connected to the building.

1. Install the panel base power infeed before the raceway cover is attached (Figure 1). If the raceway cover is already installed, pull the cover out and up from the bottom.
2. Determine from the layout which panel wireway will receive the power feed. Align the power feed the same way you would a duplex receptacle if you were installing it in a rigid wireway.
3. Slide the power feed female inserts into place in the corresponding male part of the rigid wireway. Press firmly until the spring clips lock it in place.

4. Feed the conduit end of the power feed through the receptacle access opening on the raceway cover. Install the raceway cover on the panel base. Hook the raceway cover onto the tabs on the two black support housings. Swing the raceway cover down until it snaps into place.

5. The base power infeed shown is a right-hand model. Left-hand power feeds are also available. The left or right refers to the direction the conduit goes as you look at the panel. The infeed will fit in any unused receptacle port at either end of a panel.

NOTE: The base raceway power infeeds are not allowed at worksurface height.

FIG. 1

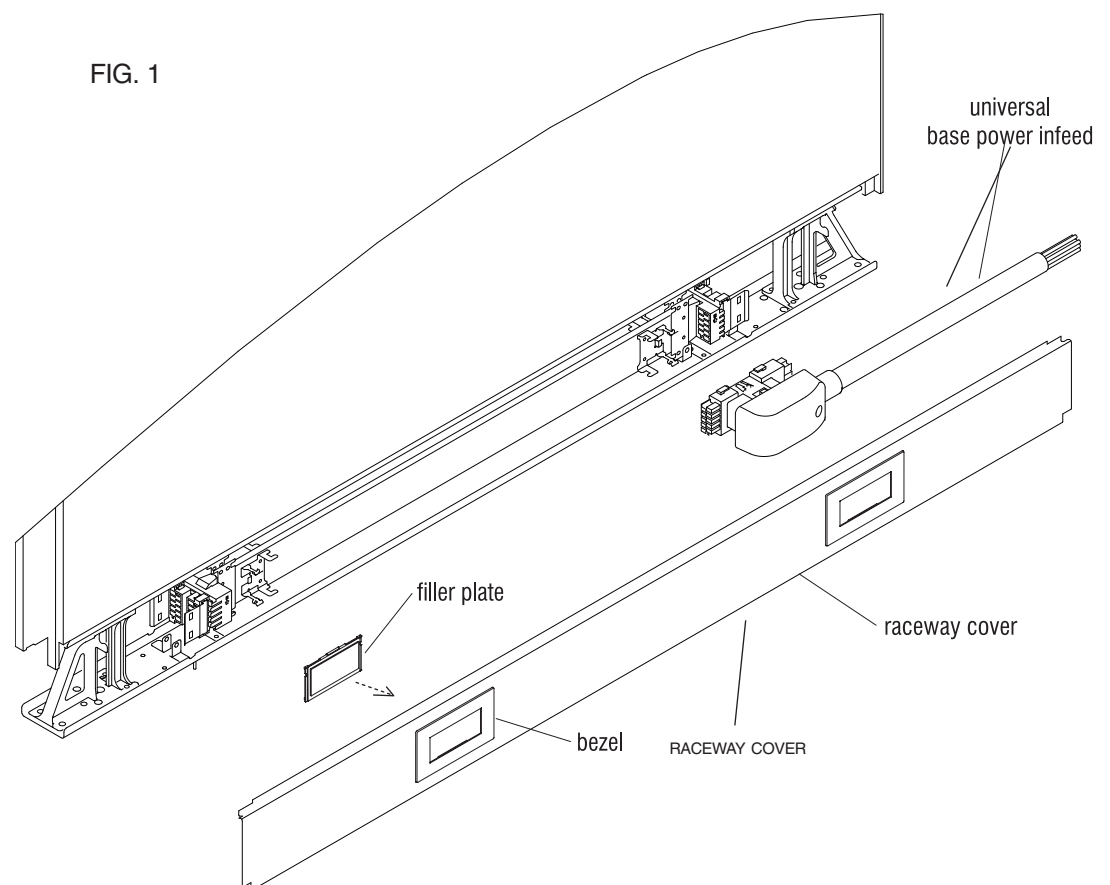

System XXI

Electrical

TOP POWER INFEED HARNESS/POWER POLE INSTALLATION

Top Power Infeed Installation

Caution: The wires in the loose end of the top power infeed must be hard-wired later by an electrician. It is not safe to perform any of the following steps if these wires are already connected.

1. Cut the top cap, from the panel you are installing the top feed on, 6" shorter. Be sure you make a clean straight 90° cut.
2. Snap the infeed trim cap in place.

Note: Before measuring the pole, be certain the panel is level and in its final location.

3. Drop a plumb line from the ceiling to a corner of the rectangular hole in the top infeed trim cap. At the ceiling, mark a 2⁵/₈" by 1¹/₂" hole starting at the same corner. The 2⁵/₈" dimension corresponds to the direction of the panel run. Cut out the hole in the ceiling tile.

4. Place the top infeed pole next to the panel so that the top of the pole touches the ceiling.

Mark a point 4" longer than the distance from the top of the trim cap to the ceiling. Use a hacksaw to cut the pole at this point (Figure 1). Be sure all burrs or sharp edges are removed after cutting.

5. If you did not do so in the panel prep., feed the top infeed harness conduit up the panel side wireway from the bottom of the panel (Figure 2). Guide the conduit through the top infeed trim cap when it reaches the top of the panel. In the raceway of the panel, plug the female terminal on the top power infeed into the male terminal of the rigid wireway.

6. Slide a ceiling trim plate around the top of the top infeed pole. Feed the top infeed harness conduit through the small channel of the top infeed pole. When the conduit has reached the top of the pole, guide the pole into the hole in the ceiling. Continue to feed the conduit into the bottom of the pole until the top infeed pole can be set into the hole in the top infeed trim cap (Figure 3).

7. Slide the trim plate up the top infeed pole until it is tight against the ceiling.

For Electrician's Reference:

To reach the infeed conduit for hard-wiring above the ceiling, remove adjacent ceiling tile. Communication cables may be fed down the larger channel of the top infeed pole at a later time.

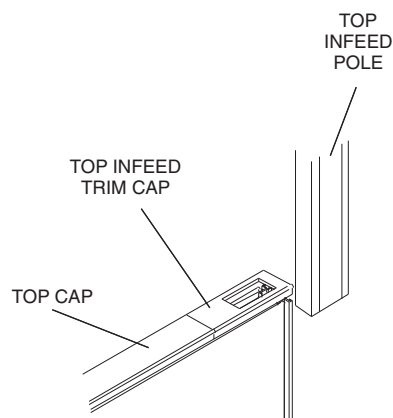

FIG. 1

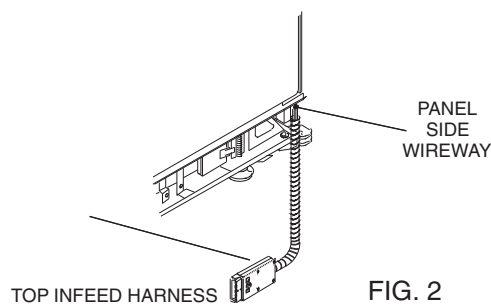

FIG. 2

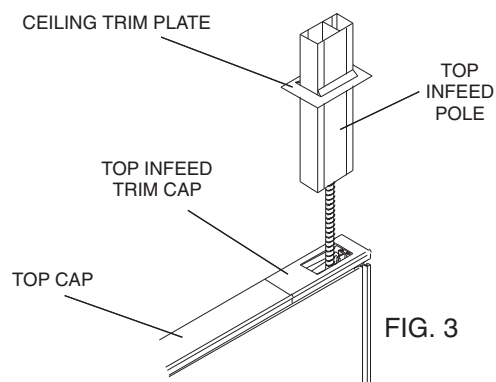

FIG. 3

Electrical

UNIVERSAL WIRE CONNECTION DIAGRAMS

6-2-2 CONNECTION DIAGRAMS

Power Infeed to Building Connections

Have a certified electrician hard-wire the panel power infeed to the building power source according to the National Electrical Code and any other applicable local codes. See the chart for proper wiring connection to available power.

6-2-2		
Receptacles available	Wires to be used	Gauge of wire
Circuit 1	Black White/Black Letters Green or Bare	12 10 12
Circuit 2	Red White/Black Letters Green or Bare	12 10 12
Circuit 3	Blue White/Black Letters Green or Bare	12 10 12
Circuit 4l	Pink White/Red Letters Green/Yellow Stripe or Gray	12 10 12
Circuit 5l	Tan White/Red Letters Green/Yellow Stripe or Gray	12 10 12
Circuit 6l	Orange White/Red Letters Green/Yellow Stripe or Gray	12 10 12

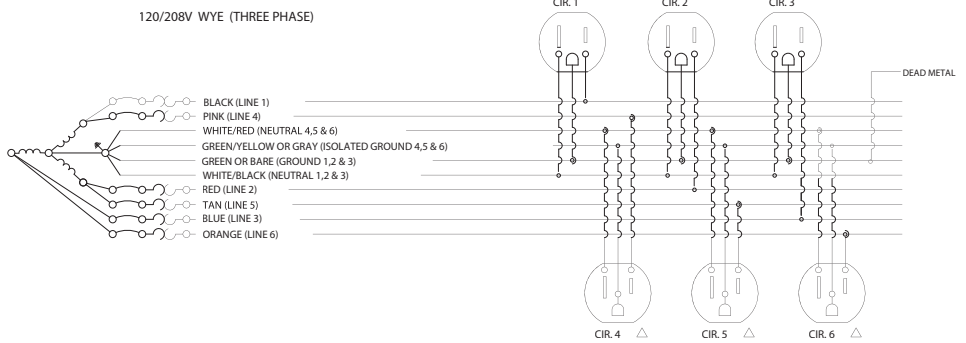
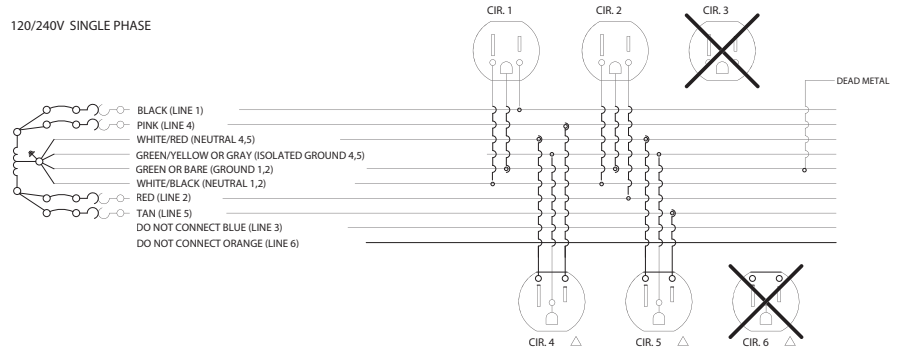

6-2-2 CONNECTION DIAGRAMS TO AN 8-WIRE BUILDING

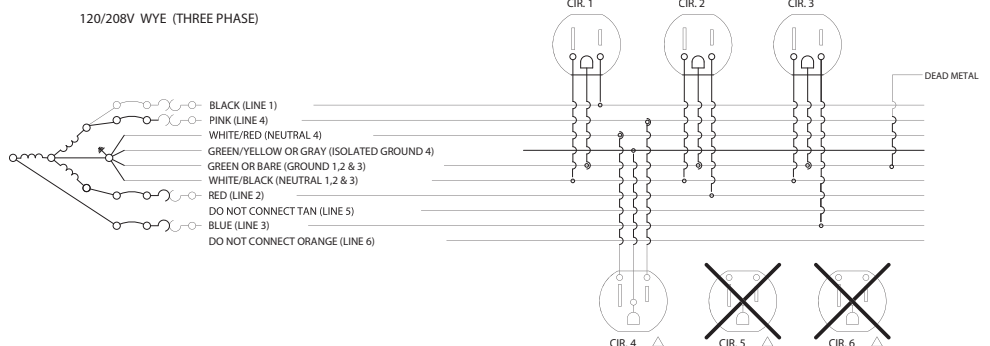
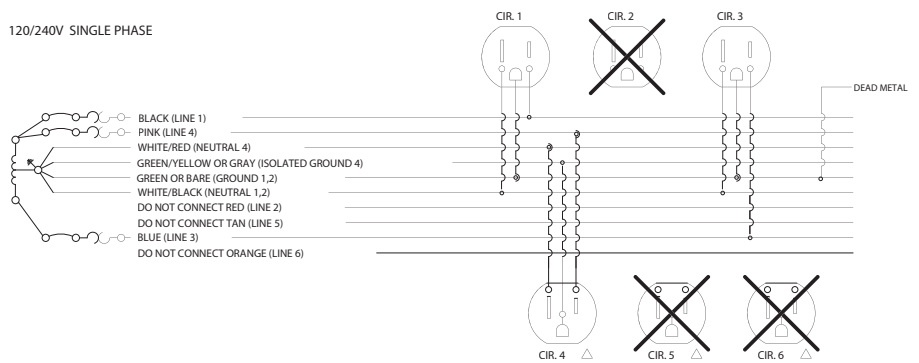

System XXI

Electrical

Power Infeed to Building Connections

Have a certified electrician hard-wire the panel power infeed to the building power source according to the National Electrical Code and any other applicable local codes. See the chart for proper wiring connection to available power.

4-4-2

Receptacles available	Wires to be used	Gauge of wire
Circuit 1	Black White/Black Letters Green or Bare	12 12 12
Circuit 2	Red White/Black Letters Green or Bare	12 12 12
Circuit 3l	Blue White/Black Letters Green/Yellow Stripe or Gray	12 12 12 12
Circuit 4l	Pink White/Purple Letters Green/Yellow Stripe or Gray	12 12 12

4-4-2 CONNECTION DIAGRAMS

120/240V SINGLE PHASE

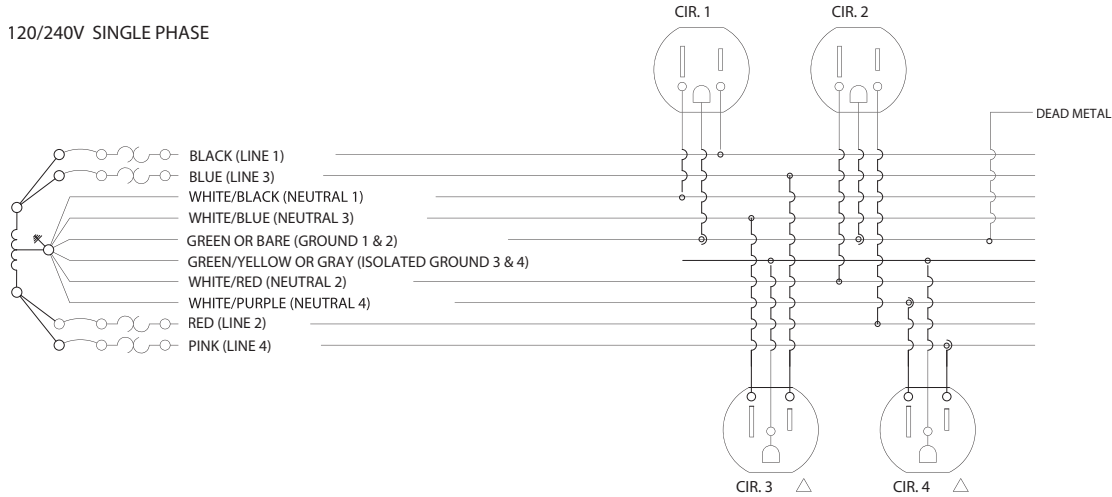

120/208V WYE (THREE PHASE)

