

# SYSTEMXXI®

## PANEL SYSTEM

### product offering catalog



Effective April 2015

# Contents

<b>Section/Product</b>	<b>Page</b>
<b>How To Order</b>	
Colors/Laminates	1
<b>Standard Product Overview</b>	2
<b>Panels</b>	
Fabric Acoustical Panels	3
Glass Panels	4
Open Frame Panels	5
Open Frame Panel Cover	5
Fabric/Laminate	6
Half Glass/Half Fabric	7
Half Open Frame/Half Fabric	8
Bottom Open Frame	9
Bottom Open Frame Cover	10
Special Bottom Open Frame Panel 7" Opening	10
Bottom Open Frame Panels With Access Openings	11
Open Frame Panels With Access Openings	12
<b>Curved Panels</b>	
Curved Fabric Panels	13
Curved Fabric/Laminate Panels	13
<b>ERP Panels (Extended Raceway Panel)</b>	
ERP Fabric Acoustical Panels	14
ERP Glass Panels	15
ERP Open Frame Panels	16
ERP Half Glass/Half Fabric	17
ERP Half Open Frame/Half Fabric	18
ERP Bottom Open Frame	19
ERP Data 1 810 Universal Raceway Cover	19
<b>Panel Trim</b>	
Panel End Cap	20
In-Line Variable Height Panel End Cap	20
T-Post (CTC) - Upholstered	21
T-Post (CTC) - Unupholstered	21
Variable Height T-Post (CTC) - Upholstered	21
Variable Height T-Post (CTC) - Unupholstered	22
2½" CTC Spacer	22
90° Corner Post (CAC) - Upholstered	23
90° Corner Post (CAC) - Unupholstered	23
Variable Height 90° Corner Post (CAC) - Upholstered	24
Variable Height 90° Corner Post (CAC) - Unupholstered	25
Two Way Top Cap	26
Three Way Top Cap	26
Four Way Top Cap	26
<b>ERP Panel Trim (Extended Raceway Panel)</b>	
ERP End of Run Caps	27
ERP T-Post (CTC) Upholstered	27
ERP 2½" CTC Spacer	28
ERP 90° Corner Post (CAC) - Upholstered	28
<b>Panel Trim Accessories</b>	
Name Plate Holder	29

# Contents

<b>Section/Product</b>	<b>Page</b>
Wall Mount	29
Adjustable Wall Mount	29
Panel Center Mount	29
<b>Stackable Panels</b>	
Stackable Panel Section - Fabric	30
Stackable Panel Section - Glass Frame	31
Stackable Panel Section - Open Frame	32
<b>Stackable Panel Trim</b>	
Stackable End of Run	33
Stackable 3 T-Post (CTC)	33
Stackable 90° Corners (CAC)	33
Stackable Variable End of Run	33
Stackable Variable 3 T-Post (CTC)	34
Stackable Variable 90° Corner (CAC)	34
<b>Panel Doors</b>	
Door	35
ERP Door	35
Rolling Screen Door	35
Door Threshold	35
<b>Electrical - Universal 10-Wire</b>	
Universal Base Feed	36
Universal Top Feed	36
Universal Panel-to-Panel Jumper	36
Universal Duplex Receptacles	37
PowerUp <sup>®</sup> Surface Mounted Power and Data	37
Universal Power Pass Through	38
Pan Retrofit Kit - 8-Wire to 10-Wire Universal	38
Converters	38
<b>Worksurfaces - 2mm Polypropylene (PP)</b>	
Rectangular	39
90° Corner	39
Curved	40
Keyboard, Left/Right/Center	40
D-Shaped - Panel Mount	40
D-Shaped - End Mount	41
Adjustable D-Leg - Panel Mount	41
Adjustable D-Leg - End Mount	41
Adjustable D-Leg	41
Conference End	42
Rectangular	43
P-Shaped Peninsula	44
Piano Peninsula	44
Radius Shoe	45
Square Shoe	45
90° Diagonal Corner	45
90° Curvilinear Corner	46
Conference End	47
D-Shaped Peninsula - Panel Mount	47
D-Shaped Peninsula - Side Mount	47
Curved	47
Dual Curvilinear 90° Corner with Mechanism	48

# Contents

<b>Section/Product</b>	<b>Page</b>
<b>Countertops - Bullnose T-Edge</b>	
Straight	49
90°	49
Curved	49
Straight for 32" Panel	49
90° for 32" Panel	50
Curved for 32" Panel	50
<b>Countertops - 2mm Polypropylene (PP)</b>	
Straight	51
90°	51
Curved	51
Straight for 32" Panel	52
90° for 32" Panel	52
Curved for 32" Panel	52
<b>Worksurface Accessories</b>	
Round Grommets - Factory Installed	53
Worksurface Support Bracket & Lock Clip	53
Worksurface Support Panel	53
C-Leg Supports	54
Worksurface Vertical Filler	54
Panel Mounted Open Support Leg	54
Panel Mounted Support Insert Leg	54
<b>Overhead Panel Storage - Laminate End</b>	
Low Shelf	55
Regular Shelf	55
Fabric Flipper Door	56
Laminate Flipper Door	56
Flipper Door Unit Backs	56
Coat Rack	57
Shelf Dividers	57
<b>Overhead Panel Storage - Steel End</b>	
Low Shelf	58
Regular Shelf	58
Universal Overhead - Fabric Front	58
Universal Overhead - Laminate Front	59
Universal Overhead - Painted Steel Front	59
Universal Overhead - Veneer Front	59
Venus Solid Color Upper Door	60
Venus Laminate Upper Door	60
Venus Fabric Upper Door	60
Overhead Shelf Dividers	61
Corner Bookshelf - T-Edge	61
Corner Bookshelf - 2mm PP	61
<b>Panel Hung Accessories</b>	
Tackboard	62
Tackboards with Backer	62
Markerboard	62

# Contents

<b>Section/Product</b>	<b>Page</b>
<b>Miscellaneous Panel Accessories</b>	
Cord Manager	63
Wall Track	63
Coat Hook/Picture Hanger	63
<b>Universal Electrical Connection Diagram</b>	
442 Connection Diagrams	64
622 Connection Diagrams	65

# System XXI Technical Specifications

All modular panel system components shall originate from ISO 9000, ISO 9001, or ISO 9002 registered facilities. SYSTEM XXI MEETS OR EXCEEDS THE REQUIRED ANSI/BIFMA X5.6-2010 PANEL SYSTEMS TESTS.

## UL Listed

System XXI panels are listed to applicable U.S. and Canadian safety standards and requirements by Underwriters Laboratories Inc. Two of the standards used to evaluate System XXI are UL 1286, Office Furnishings and UL 723, Standard for Test for Surface Burning Characteristics of Building Materials.

## PANELS AND ACCESSORIES

### A. Fabric Acoustical Panels

1. Product Offering – The panel shall be offered in heights of 32", 42", 48", 54", 62", 66", 72" and 80". The panel widths offered shall be 12", 18", 24", 30", 36", 42", 48", 54" and 60". The panel shall be offered in a non-powered and powered version. The panel shall be 2½" thick.
2. Panel Construction
  - a. Fabric Panel Core – The panel core shall consist of a galvanized steel frame made from roll-formed steel "U" channels around the perimeter of the panel, two steel reinforcement gussets on each corner and an expanded steel skin. The "U" channels shall be positioned so the open side is towards the frame perimeter permitting easy cable access. The frame, gussets and skin shall be resistance welded to form a rigid structural unit. On all panels wider than 42", a third vertical support member shall be resistance welded to the frame. The panel shall receive its acoustical properties by the use of formaldehyde-free fiberglass. This fiberglass acoustical barrier shall be enclosed within the steel panel frame and 20-gauge expanded metal sides. The fabric panel shall be tackable with the use of "T" pins.
  - b. Panel Raceway – The raceway shall consist of the following components:
    - (1) Raceway Pan – A 14-gauge galvanized steel pan shall run the width of the panel and form a third horizontal structural cross member. Two threaded steel nuts shall be attached to the raceway pan for attachment of glides. The raceway pan shall allow for the attachment of the interlocks, glides, support housings and spring clips.
    - (2) Support Housing – Two fiberglass filled, structural nylon support housings shall be included in each panel. The support housing shall provide rigidity to the panel assembly and support at each end of the panel.
    - (3) Interlock Block – The base of each panel side shall contain an interlock block. The interlock shall be made from either die cast aluminum or die cast zinc. The interlocks of one panel shall mate with interlocks of adjacent panels providing lateral support and uniform height.
    - (4) Glide – The glides shall provide for 3½" of vertical adjustment. Each panel shall contain a minimum of two glides.
    - (5) Raceway Covers – The raceway covers shall be offered in a powered and non-powered version. They shall be made of 22-gauge powder-coated steel and shall be 4" high. The powered version shall contain openings for the use of U.S. standard receptacles. These openings shall have an injection-molded bezel and filler to cover the opening when receptacles are not being used. Raceway covers shall be secured with a roof top latch and spring clips at the bottom.

- c. Panel Trim Rails – The panel trim rail shall be made of extruded aluminum. The trim rail shall be secured by sliding the rail onto pre-formed flanges extending the entire length of the vertical ends of the panel and fastened with screws. The trimrail shall be slotted to allow for the placement of hang-on components in 1" vertical increments.
- d. Trim on Panel
  - (1) Top Cap – All panels shall have a top trim cap made from either rigid PVC with trim color per-meating throughout the entire part or metal powder coat painted with textured surface to hide finger-prints. Installation of the top cap shall be a press fit without the use of tools. The top cap shall extend the full length of the panel top and shall be joined to the adjacent top cap by a plastic top cap sleeve.
  - (2) Panel-To-Panel Connectors – The panel-to-panel connector must be universal for simplicity in specification and inventory. Panels shall be joined by a full height extruded polypropylene hinge. The hinge shall attach one panel to the next by sliding into pre-formed slots on the panel trim rail. This same hinge shall be used to secure panels to corner posts, "T" posts and wall mount.
- e. Upholstery – Fabric shall be held in place by an elastic extruded spline rolled into the welting groove on the panel vertical and horizontal members. The fabric shall be field replaceable.

### Fabric Disclaimer

"Fabric will be applied as swatched by the fabric manufacturer. Fabric that is required to be applied differently than is watched will need a Special Cost Request written specifying the direction the fabric is to be applied. The posted standard lead time will apply to the Special Cost Request."

1. Acoustical Properties – The modular office systems acoustical properties will have been tested at independent laboratories using random production samples. The acoustical properties shall be determined by using three different testing procedures.
  - a. Noise Reduction Coefficient (Test Method ASTM C-423) – The standard acoustical panels shall have an NRC rating of at least .75.
  - b. Speech Privacy/Noise Isolation Class (NIC) – The modular office system shall have an NIC barrier ranking of 21 at a distance of 7'. The modular office system shall have an NIC flanking rating of 22 at a distance of 12'.
4. Cable Management Capabilities of Straight Panels – Each straight panel shall allow cable management access around the entire perimeter of the panel. Separation of communication and power cables into top and bottom raceways shall be accommodated. Capacity shall be up to 40 (25 pair) cables. Complete perimeter cable management must be incorporated as a standard feature of each straight panel.

### B. Curved Fabric Panels

1. Product Offering – The panels shall have a radius of 24" and be available in heights of 32", 42", 48", 54", 62", 66", 72" and 80".
2. Construction
  - a. Panels shall be 2½" thick constructed of a metal and wood frame, aluminum septum and fiberglass sandwiched between radius plywood skins, covered with fiberglass and fabric. The panels shall blend aesthetically with straight panels.
  - b. Raceway Construction – This assembly shall include a steel raceway pan and include support housings, aluminum die cast interlocks with 3½" adjustable glides, with 4" high steel raceway covers.

# System XXI Technical Specifications

## C. Glazed Panels

1. Product Offering – Glazed panels shall be offered in 12", 18", 24", 30", 36", 42", and 48" widths and in 42", 48", 54", 62", 66", 72" and 80" heights and shall be available in a non-powered and powered version.
2. Construction
  - a. Panel shall consist of 1/4" bronze or clear tempered glazed surrounded by powder-coated aluminum extrusion frame and shall be 2½" thick. The trim of the glazed panel is identical to the fabric panel.
  - b. The cable capacity shall be the same as in the fabric panels.

## D. Half Glazed/Half Fabric Panels

1. Product Offering – Panels are offered in 24", 30", 36", 42", and 48" widths and in 54", 62", 66", 72" and 80" heights and shall be available in a non-powered and powered version.
2. Construction
  - a. The panel shall be a combination of the same materials used to build the glazed panel and standard acoustical panel.
  - b. The cable capacity shall be the same as in the fabric panels.

## E. Half Open/Half Fabric Panels

1. Product Offering – Panels will be offered in 24", 30", 36", 42", and 48" widths and in 54", 62", 66", 72" and 80" heights and shall be available in a non-powered and powered version.
2. Construction
  - a. The construction of the half open frame/half fabric panel shall be identical to the half glazed/half fabric panel with the exception that the glaze is removed and the groove for the glaze is filled by a rigid PVC extruded filler.
  - b. The cable capacity shall be the same as in the fabric panels.

## F. Door

1. Product Offering – Panel doors are available in 42" wide and 80" and 84" height to provide visual and acoustical privacy.
2. Construction
  - a. The construction of the door shall be corrugated cardboard honeycomb wrapped by hardwood stiles, MDF rails, faced with hardboard and covered with high-pressure laminate. The frame shall be powder-coated aluminum to match panel frames.
  - b. The door is available non-locking or locking.

## G. Rolling Screen Door

1. Product Offering – Sliding doors are available in 48" wide x 66" tall for use on typical 42" openings on at least 66" tall panels. Door can be mounted in left or right hand configurations and is available with a clear or frosted poly insert.
2. Construction
  - a. The construction of the door shall be a poly insert wrapped by an aluminum frame. The door sits on two acrylic wheels and tracks parallel to the panel by means of guide channels. The guide channels are mounted directly to the trimrails. Doors can be used on openings of 37"-42" wide while maintaining ADA clearances.

## H. Wall Mounts

1. The panel system shall allow for fastening a panel run to a wall. The wall mounts shall consist of an aluminum extrusion to allow for panels to be attached to the existing building walls. A panel shall be secured to a wall mount with a universal panel hinge. Method of attachment to the existing building depends on the existing wall construction.

## I. Adjustable Wall Mounts

1. The adjustable wall mounts shall consist of an aluminum extrusion along with 1/8" thick cork/rubber washers enclosed in a steel "U" channel to allow panels to be attached to existing building walls. This unit has a total adjustable depth of 5/8" in 1/8" increments. Method of attachment to the existing building depends on the existing wall construction.

## J. 90° Corner Post Trim

1. Product Offering – Trim shall be offered upholstered and unupholstered.
2. Construction
  - a. The modular office system shall include a 90° corner post trim whenever panels are joined at 90°. This corner post trim shall consist of an inside rigid PVC extrusion offered in the same colors as the panel trim. An outside rigid PVC extrusion shall snap into the inner extrusion and be available unupholstered and upholstered. The 90° corner post trim shall have a plastic or metal top cap and painted metal bottom cap in order to aesthetically connect with the panel top caps and the raceway covers. The corner post shall be attached to adjacent panels with the universal panel hinge. Optional painted metal trim available. Includes metal top cap and bottom cover.

## K. Variable Height Corner Post Trim

1. Product Offering – Trim shall be offered upholstered and unupholstered.
2. Construction
  - a. The modular office system shall include a variable height corner post whenever two panels of different heights meet in T-conditions. The variable height corner post consists of an inside rigid PVC extrusion offered in the same colors as the panel trim. An outside rigid PVC extrusion shall snap into the inner extrusion. The variable height corner post trim shall have a plastic or metal top cap in order to aesthetically connect with the panel top caps and the raceway covers. The corner post shall be attached to adjacent panels with the universal panel hinge. Optional painted metal trim available. Includes metal top cap.

## L. T-Post Trim

1. Product Offering – Trim shall be offered upholstered and unupholstered.
2. Construction
  - a. The modular office system shall include "T" post panel trim whenever three panels are joined forming a "T" connection. Components are identical in concept as the 90° corner post trim and shall be fastened to adjacent panels with the universal panel hinge and include a painted metal bottom cap.

# System XXI Technical Specifications

## M. Variable Height T-Posts

1. Product Offering – Trim shall be offered upholstered and unupholstered.
2. Construction
  - a. The modular office system shall include “T” post panel trim whenever three panels are joined forming a “T” connection or for 4-way conditions. Components are identical in concept as the variable height corner post trim and are fastened to adjacent panels with the universal panel hinge.

## N. Panel End Caps

1. All exposed ends of a panel run shall be covered with a vertical trim cap. Panel end caps shall be made from either an extruded rigid PVC with the trim color permeated throughout the entire part or metal powder coat painted and surface textured to hide fingerprints. End caps shall be installed using a snap fit method and require no assembly or disassembly tools. Panel end cap lengths shall correspond to panel heights. An end of run top cap shall be included with each panel end cap. Optional painted metal trim available. Includes metal top cap.

## O. In-Line Variable Height Panel End Caps

1. All exposed ends of a panel run shall be covered with a vertical trim cap when in-line panels are of different heights. Panel end caps shall be made from either an extruded PVC with the trim color permeated throughout the entire part or metal powder coat painted and the surface textured to hide fingerprints. End caps shall be installed using a snap fit method and require no assembly or disassembly tools. Panel end cap lengths shall correspond to the different panel heights. An end of run top cap shall be included with each end cap. Optional painted metal trim available. Includes metal top cap.

## P. Two-Way Caps

1. Injection-molded or painted metal two-way top caps shall be available for spanning the gap when panels are assembled requiring a two-way cap.

## Q. Four-Way Caps

1. Injection-molded or painted metal four-way caps shall be available to cover the gap that exists when four panels are connected to each other at 90°.

## R. Panel Center Mount

1. A panel center mount shall allow a panel to be connected at 90° along an adjoining panel at any point except directly on the panel joint. It shall be available only to join panels of similar height and does not allow for the transfer of power.

## S. In-Line Fabric Spacer

1. The in-line fabric spacer shall be an upholstered plastic and aluminum extrusion that is used to provide a 2½” space along a run of panels. The in-line fabric spacer consists of two PVC extrusions that attach to a rigid aluminum extrusion. The bottom trim plate is painted metal and the top cap can be either an extruded PVC or powder coat painted part. The part also includes two polypropylene hinges. The spacer allows panel runs to line up with each other. Optional painted metal in-line spacer available. Includes metal top cap and two metal bottom covers.

## WORKSURFACES AND ACCESSORIES

### A. Rectangular Worksurfaces

1. Product Offering – The standard rectangular worksurface shall be offered in widths of 24”, 30”, 36”, 42”, 48”, 54”, 60”, 66”, 72”, 78”, and 84”. The worksurfaces shall be offered in 20”, 24” and 30” depths.

2. Construction – Worksurfaces shall be available in high-pressure laminate. Surface shall be constructed of a 45 lb. density particleboard core. The laminate worksurface shall consist of a high-pressure laminate face with phenolic backer. Laminate worksurface edges shall be trimmed with either a polypropylene edge banding or extruded flat polypropylene T-molding.
3. All worksurfaces shall be pre-drilled for cantilever brackets and hanging pedestals. The 60” wide surfaces shall have an integrated steel reinforcement to allow adequate support for load bearing. Worksurfaces 60” and wider shall include additional left-hand cantilever bracket. The worksurface shall be supported by one piece 14-gauge steel cantilever brackets. These brackets shall prevent dislodgment by the use of an integral top bracket tooth.

### B. Curved Worksurfaces

- The following curved worksurfaces shall be available:
1. Piano Peninsula, Radius Corner Peninsula, “P” Top Peninsula, Shoe Peninsula, and “D” Shaped worksurfaces.
  2. Construction – The construction shall be identical to that specified for the rectangular worksurfaces, with the exception that there shall be no flat vinyl T-molding edge available in the laminate series.

### C. Transitional Surface

1. The following transitional worksurfaces shall be available: Conference End, Quarter Round Transitional worksurfaces.
2. Construction – The construction shall be identical to that specified for the rectangular worksurfaces.

### D. Mobile Surfaces

1. The following mobile worksurfaces shall be available: Teardrop and Semi-Circle worksurfaces.
2. Construction – The construction shall be identical to that specified for the rectangular worksurfaces.

### E. 90° Corner Worksurfaces

1. Product Offering – The 90° worksurfaces shall be available in: Diagonal, Curvilinear, Dual Curvilinear and Wing options in various widths and depths.
2. Construction – Construction of the 90° worksurface shall be identical to that specified for rectangular worksurfaces. The 90° diagonal corner worksurface will have a center round grommet as standard with T-mold edge. The curvilinear, dual curvilinear and wing options will have slimline grommets as standard.

### F. Variable Height Adjustment Mechanism

1. Product Offering – The variable height adjustment mechanism mounts underneath the dual curvilinear front worksurface and is available in black powder-coated finish only.
2. Construction – The construction shall be steel construction finished in a durable black powder coat and offers front surface height adjustment and tilt. Height adjustment of 5½” below and 7” above worksurface. Tilt adjustment of 9° positive and 15° negative. Mechanism has a 20 lb. capacity spring assist for ease of adjustment.

### G. Worksurface Vertical Fillers

1. Product Offering – A worksurface vertical filler shall be available to fill the gap when one worksurface drops from the standard 29” down to an adjacent 26” secretarial typing height worksurface. Worksurface vertical fillers shall be available in 20”, 24” and 30” widths. The height of the worksurface vertical filler shall be 3”.
2. Construction – The construction of the worksurface vertical filler shall be 16-gauge steel, powder coat painted to the trim colors of the panel. The worksurface vertical filler shall be attached to the worksurface through the use of wood screws.



# System XXI Technical Specifications

## H. Worksurface Grommets

1. Product Offering – Circular worksurface grommets, 2½" I.D. and 3" O.D. shall be field installed. Trapezoidal shaped worksurface grommets 2½" x 6" shall be factory installed.
2. Construction – The worksurface grommet shall be a two-piece molded component with the ability to remove the top cover to allow full access to the grommet hole.

## I. Worksurface Support Panels

1. Product Offering – The support panels shall be available in the following sizes: 26" and 29" height and 20", 24" and 30" depth.
2. Construction – The worksurface support panel shall be 1¼" thick and constructed of 45 lb. density particleboard with high-pressure laminate. The front edge of the high-pressure laminate panel shall be a 3mm vinyl edge. The worksurface support panel brackets shall prevent dislodgement from the trim rail of the panel. There shall also be an 18-gauge support bracket that attaches to the side of the support panel and to the underside of the worksurface.

## J. Countertops

1. Product Offering – The countertops shall be offered in widths of 24", 30", 36", 42", 48", 54", 60", 66", 72" and 84" with a countertop depth of 16". Countertops shall also be available for 90° corner and curved corner applications.
2. Construction – Construction of the countertops shall be identical to the construction for the rectangular worksurfaces. The bracket to support the countertops shall consist of steel brackets and locking clips to prevent dislodgement. The brackets are mounted on the inside of the workstation allowing for a 4" extension over the top of the panel to conform with ADA guidelines. The countertops will also accommodate a task light.

## K. Wall Track

1. Product Offering – Wall track shall be available to allow for hanging of components onto an existing structural wall in the identical method as if the components were hung on System XXI panels available in either 66" length or 84" length.
2. Construction – The wall track shall consist of a double slotted aluminum extruded rail with powder coat finish in the panel trim colors.

## L. Coat Hook/Picture Hanger

1. Product Offering – Coat hook shall be available to allow for hanging of coats or pictures.
2. Construction – The coat hook shall consist of injection-molded plastic available in panel trim colors and shall be attached to top edge before top cap is installed.

## STORAGE AND ACCESSORIES

### A. Regular Shelf

1. Product Offering – The product shall be offered in widths of 24", 30", 36", 42", 48", 54" and 60". The overall dimensions of the end panels shall be 16½" high and 14½" deep. The shelf depth shall be 13¼".
2. Construction – The end panels shall be constructed of 14-gauge steel with a powder coat finish. The end panels shall have self-locking mounting tabs formed into the back edge. The shelf shall be an 18-gauge steel weldment with a powder coat finish. The front edge of the shelf shall be a PVC extrusion that also provides space for a concealed flush mount task light.

### B. Low Shelf

1. Product Offering – The product shall be offered in widths of 24", 30", 36", 42", 48", 54" and 60". The overall dimensions of the end panels shall be 9½" high and 14½" deep. The shelf depth shall be 13¼".

2. Construction – The end panels shall be constructed of 14-gauge steel with a powder coat finish. The end panels shall have self-locking mounting tabs formed into the back edge. The shelf shall be an 18-gauge steel weldment with a powder coat finish. The front edge of the shelf shall be a PVC extrusion that also provides space for a concealed flush mount task light.

## C. Overhead Cabinet

1. Product Offering – The product shall be offered in widths of 24", 30", 36", 42", 48", 54" and 60". The overall dimensions of the end panels shall be 16½" high and 14½" deep. The shelf depth shall be 13¼".
2. Construction – The construction of the end panels and shelves of the overhead cabinet shall be identical to the low/regular shelf. Door fronts shall be offered in steel, fabric or laminate, with a dual durometer extruded handle. The door front will operate on a rack and pinion gear system and will utilize a center lock mechanism. The door front will store recessed inside the cabinet with the handle exposed. The steel door front shall be of honey-comb core construction with a powder coat finish. The construction of the fabric door front shall be identical to the steel door front except that the outer surface of the door front is covered with fabric. The laminate door front shall be high-pressure laminate covering a particleboard core.

## D. Paper Management

1. Product Offering – The following products shall be available:
  - a. Tool Rail
  - b. Hanging Folder Holder
  - c. Paper Tray Unit
  - d. Diagonal Storage Unit
  - e. Vertical Storage Unit
  - f. Telephone Caddy
  - g. CD Holder
  - h. Accessory Tray
  - i. Pencil Cup
2. Construction
  - a. Tool Rail – The tool rail shall be constructed from a powder-coated aluminum which shall attach to the panel. The rail shall consist of four slots to accept paper management components.
  - b. The paper management accessories shall be constructed of molded plastic and shall be available in five finishes and shall mount to the tool rail with molded hooks.

## E. Shelf Dividers

1. Product Offering – Shelf dividers shall be offered in the same color trim as the panels.
2. Construction – The shelf dividers shall be powder-coated steel. Installation or removal shall be accomplished without the use of tools or fasteners.

## F. Tackboards

1. Product Offering – Tackboards shall be available in 12", 16", 30", and 48" heights and in 24", 30", 36", 42", 48", and 60" widths.
2. Construction – The tackboard shall be constructed of 3/4" industrial insulation board covered with fabric. The mounted brackets shall be steel powder-coated and attached to the coreboard with T-nuts and machine screws. Fabric shall be attached to the coreboard with staples.

## G. Markerboards

1. Product offering – Markerboards shall be available in 16" and 32" height and 24", 30", 36", 42", 48", 54", and 60" widths.

# System XXI Technical Specifications

2. Construction – The markerboard shall be constructed of painted aluminum framed units with a white porcelain painted marker surface. The markerboard surface shall be magnetic with an eraser and markers. The markerboards will mount in the trim rail slots of a panel the same width as the board or to wall track.

## **ELECTRICAL COMPONENTS**

The factory-installed U.S. standard electrical system supplied for the modular office system shall be an 10-wire design. This design has 2 options, the 622 and 442. 622 has 6 hot wires, 2 neutral wires and 2 ground wires. 442 has 4 hot wires, 4 neutral wires and 2 ground wires. Each circuit has a rated capacity of 20 amps.

### **A. Panel Rigid Wireway**

A rigid one-piece wireway shall be attached to the raceway panel by four machine screws. The wireway design shall allow for the snap connection of the rigid wireway of one panel to another through the use of rigid connection blocks.

### **B. Base Infeeds**

The electrical system shall permit power infeed along the base raceway of the panel. Base feed power shall feed into the rigid wireway of the panel raceway through the use of a slip connection and attach to the rigid wireway by screws. The standard base feed shall be constructed of a 6' long, 1/2" liquid-tight flexible metal conduit that contains 10 wires with a receptacle type design allowing for quick installation and removal. The infeed shall be non-handed. 12', 18' and 24' lengths are also available.

### **C. Top Infeeds**

The electrical system shall permit power infeed through the top of the panel. The top feed assembly shall consist of a 7" extruded aluminum power pole, top cap and ceiling trim plate and 12' flexible conduit containing 10 wires to span the ceiling with a snap fit attachment for connection to the rigid wireway. The interior of the power pole shall be divided for power and communication management. A 10' pole with an 18' infeed is available as a special.

### **D. Data Top Feed**

The data top feed consist of an aluminum extruded power pole, top cap and ceiling trim pieces but does not include power infeed wiring.

### **E. Power Pass-Through**

The electrical system shall provide for a method of passing power from one powered panel through the raceway of a non-powered panel and connected to the powered rigid wireway of the next panel. This power pass through shall attach from the one powered panel to the next with a snap fit connection that requires no tools for assembly.

### **F. Receptacles**

The receptacles for the modular electrical system shall be made of steel and injection-molded components which slip fit into the rigid wireways of the panels and fasten securely. The rated capacity of the receptacles shall be 15 amps.

### **G. Electrical System Test Requirements**

The panel system, including the modular U.S. electrical components, shall be listed to applicable UL standards and requirements by Underwriters Laboratories, Inc.

# How to Order

## Product Number Specification

1. Specify the exact product size-style-color-trim desired by "constructing" the exact product number.
2. List the base product number that corresponds with the exact product dimensions selected.
3. Read product description copy to identify the options that need to be specified.
4. When applicable, add electrical code to product number:  
**(Example:)** TN (non-powered), T6 (powered, 10-wire), etc.
5. When applicable, (next) add trim color code letter to the product number.  
Trim Color Codes:   Black – BL  
                          Blue Grey – GR  
                          Light Tone – LG  
                          Sand – SA  
                          Warm Grey – WG
6. When applicable, (next) add the laminate color code letter to the product number.

# Standard Products Overview

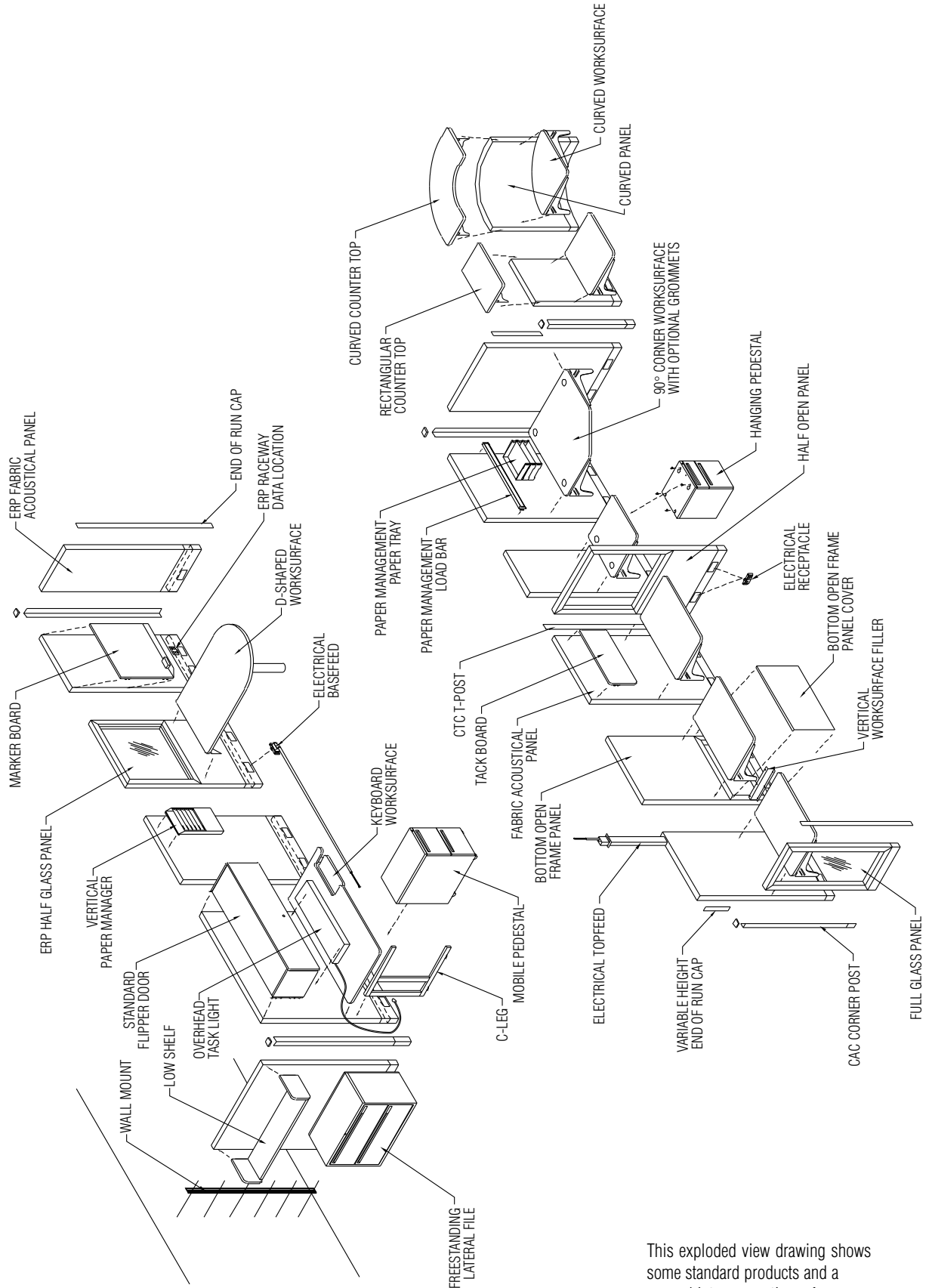

This exploded view drawing shows some standard products and a general interconnection reference.

# Panels

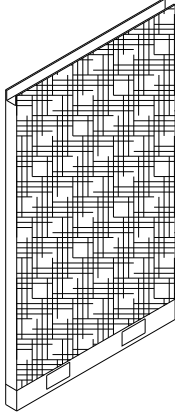

## Fabric Acoustical Panels

- Panel is constructed of a metal frame, aluminum septum and fiberglass between expanded metal, covered with fiberglass and fabric.
- NRC rating is .75  
Product is UL1286 listed.
- Class A fire rated. Certain fabrics only.
- Meets BIFMA standards: X5.6-1993.
- Panels are connected through single piece poly hinges.
- **Panel-to-Panel Power Connectors must be specified separately.**
- Powered panel raceway includes four locations for receptacles and cable access for panels wider than 24".  
24" panel contains two receptacle locations. **12" and 18" wide panels are power pass through only.**

- Product includes complete panel assembly with connectors (panel, hinges, sleeve, side trim rails, top cap, base raceway).
- Specify ten-wire powered (T4) 442 system; or ten-wire powered (T6) 622 system; or (TN) non-powered.
- Specify trim color.

To order (Example): CI-CP-2442-T6-BL-(XXX)  
"Fabric Acoustical Panel, 24-inch width, 42-inch height, ten-wire powered 622, black trim, (fabric color)."

Product	Width	Height
CI-CP-1232	12"	32"
CI-CP-1242	12"	42"
CI-CP-1248	12"	48"
CI-CP-1254	12"	54"
CI-CP-1262	12"	62"
CI-CP-1266	12"	66"
CI-CP-1272	12"	72"
CI-CP-1280	12"	80"
CI-CP-1832	18"	32"
CI-CP-1842	18"	42"
CI-CP-1848	18"	48"
CI-CP-1854	18"	54"
CI-CP-1862	18"	62"
CI-CP-1866	18"	66"
CI-CP-1872	18"	72"
CI-CP-1880	18"	80"
CI-CP-2432	24"	32"
CI-CP-2442	24"	42"
CI-CP-2448	24"	48"
CI-CP-2454	24"	54"
CI-CP-2462	24"	62"
CI-CP-2466	24"	66"
CI-CP-2472	24"	72"
CI-CP-2480	24"	80"
CI-CP-3032	30"	32"
CI-CP-3042	30"	42"
CI-CP-3048	30"	48"
CI-CP-3054	30"	54"
CI-CP-3062	30"	62"
CI-CP-3066	30"	66"
CI-CP-3072	30"	72"
CI-CP-3080	30"	80"
CI-CP-3632	36"	32"
CI-CP-3642	36"	42"
CI-CP-3648	36"	48"
CI-CP-3654	36"	54"
CI-CP-3662	36"	62"

Product	Width	Height
CI-CP-3666	36"	66"
CI-CP-3672	36"	72"
CI-CP-3680	36"	80"
CI-CP-4232	42"	32"
CI-CP-4242	42"	42"
CI-CP-4248	42"	48"
CI-CP-4254	42"	54"
CI-CP-4262	42"	62"
CI-CP-4266	42"	66"
CI-CP-4272	42"	72"
CI-CP-4280	42"	80"
CI-CP-4832	48"	32"
CI-CP-4842	48"	42"
CI-CP-4848	48"	48"
CI-CP-4854	48"	54"
CI-CP-4862	48"	62"
CI-CP-4866	48"	66"
CI-CP-4872	48"	72"
CI-CP-4880	48"	80"
CI-CP-5432	54"	32"
CI-CP-5442	54"	42"
CI-CP-5448	54"	48"
CI-CP-5454	54"	54"
CI-CP-5462	54"	62"
CI-CP-5466	54"	66"
CI-CP-5472	54"	72"
CI-CP-5480	54"	80"
CI-CP-6032	60"	32"
CI-CP-6042	60"	42"
CI-CP-6048	60"	48"
CI-CP-6054	60"	54"
CI-CP-6062	60"	62"
CI-CP-6066	60"	66"
CI-CP-6072	60"	72"
CI-CP-6080	60"	80"

# Panels

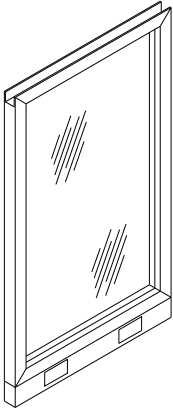

## Glass Panels

- Painted aluminum frame with 1/4" clear or bronze tempered glass.
- Product is UL 1286 listed.
- Panels are connected through single piece poly hinges.
- **Panel-to-Panel Power Connectors must be specified separately.**
- Powered panel raceway includes four locations for receptacles and cable access for panels wider than 24".
- 12" and 18" wide panels are power pass-through only.
- 24" panel contains two receptacle locations.
- Product Includes complete panel assembly with connectors (panel, hinges, sleeve, side trim rails, top cap, base raceway).
- Specify ten-wire powered (T4) 442 system; or ten-wire powered (T6) 622 system; or (TN) non-powered.
- Specify trim color.
- **Glass panels are available with clear or bronze glass. Add -SM to model # if requesting bronze glass (example) CI-CGP-2454-SM-T6-SA.**

To order (Example): CI-CGP-2454-T6-SA  
 "Glass Panel 24-inch width, 54-inch height, ten-wire powered 622, sand trim."

Product	Width	Height
CI-CGP-1248	12"	48"
CI-CGP-1254	12"	54"
CI-CGP-1262	12"	62"
CI-CGP-1266	12"	66"
CI-CGP-1272	12"	72"
CI-CGP-1280	12"	80"
CI-CGP-1848	18"	48"
CI-CGP-1854	18"	54"
CI-CGP-1862	18"	62"
CI-CGP-1866	18"	66"
CI-CGP-1872	18"	72"
CI-CGP-1880	18"	80"
CI-CGP-2448	24"	48"
CI-CGP-2454	24"	54"
CI-CGP-2462	24"	62"
CI-CGP-2466	24"	66"
CI-CGP-2472	24"	72"
CI-CGP-2480	24"	80"
CI-CGP-3048	30"	48"
CI-CGP-3054	30"	54"
CI-CGP-3062	30"	62"

Product	Width	Height
CI-CGP-3066	30"	66"
CI-CGP-3072	30"	72"
CI-CGP-3080	30"	80"
CI-CGP-3648	36"	48"
CI-CGP-3654	36"	54"
CI-CGP-3662	36"	62"
CI-CGP-3666	36"	66"
CI-CGP-3672	36"	72"
CI-CGP-3680	36"	80"
CI-CGP-4248	42"	48"
CI-CGP-4254	42"	54"
CI-CGP-4262	42"	62"
CI-CGP-4266	42"	66"
CI-CGP-4272	42"	72"
CI-CGP-4280	42"	80"
CI-CGP-4848	48"	48"
CI-CGP-4854	48"	54"
CI-CGP-4862	48"	62"
CI-CGP-4866	48"	66"
CI-CGP-4872	48"	72"
CI-CGP-4880	48"	80"

# Panels

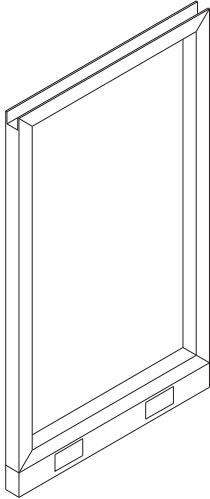

## Open Frame Panels

- Panel is constructed of a painted aluminum frame.
- Product is UL 1286 listed.
- Panels are connected through single piece poly hinges.
- **Panel-to-Panel Power Connectors must be specified separately.**
- Powered panel raceway includes four locations for receptacles and cable access for panels wider than 24".
- 24" panel contains two receptacle locations.
- Product includes complete panel assembly with connectors (panel, hinges, sleeve, side trim rails, top cap, base raceway).

- Specify ten-wire powered (T4) 442 system; or ten-wire powered (T6) 622 system; or (TN) non-powered.
- Specify trim color.

To order (Example): CI-OFP-2442-T4-BL  
 "Open Frame Panel, 24-inch width, 42-inch height, ten-wire powered 442, black trim."

Product	Width	Height
CI-OFP-2432	24"	32"
CI-OFP-2442	24"	42"
CI-OFP-2448	24"	48"
CI-OFP-3032	30"	32"
CI-OFP-3042	30"	42"
CI-OFP-3048	30"	48"
CI-OFP-3632	36"	32"
CI-OFP-3642	36"	42"

Product	Width	Height
CI-OFP-3648	36"	48"
CI-OFP-4232	42"	32"
CI-OFP-4242	42"	42"
CI-OFP-4248	42"	48"
CI-OFP-4832	48"	32"
CI-OFP-4842	48"	42"
CI-OFP-4848	48"	48"

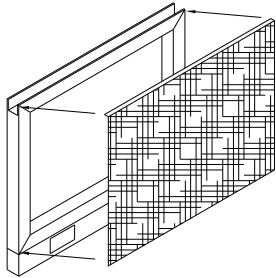

## Open Frame Panel Covers

- Cover is formed steel covered with fabric.
- Cover is held in place by a hanging flange and hook and loop patches.
- Cover is designed to give open frame panels the look of a fabric acoustic panel. Removing the cover allows access to areas behind the open frame panel (wall or column elec. or comm. boxes).

To order (Example): CI-OFC-3032-(XXX)  
 "Open frame cover for 30" wide 32" high open frame panel, (fabric color)."

Product	Width	Height
CI-OFC-0632	6"	32"
CI-OFC-0642	6"	42"
CI-OFC-0648	6"	48"
CI-OFC-1230	12"	30"
CI-OFC-1232	12"	32"
CI-OFC-1242	12"	42"
CI-OFC-1248	12"	48"
CI-OFC-1254	12"	54"
CI-OFC-1266	12"	66"
CI-OFC-2432	24"	32"
CI-OFC-2442	24"	42"
CI-OFC-2448	24"	48"

Product	Width	Height
CI-OFC-3032	30"	32"
CI-OFC-3042	30"	42"
CI-OFC-3048	30"	48"
CI-OFC-3632	36"	32"
CI-OFC-3642	36"	42"
CI-OFC-3648	36"	48"
CI-OFC-4232	42"	32"
CI-OFC-4242	42"	42"
CI-OFC-4248	42"	48"
CI-OFC-4832	48"	32"
CI-OFC-4842	48"	42"
CI-OFC-4848	48"	48"

# Panels

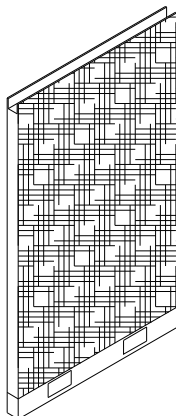

## Fabric/Laminate Panels

- Panel is constructed of a metal frame, with fiberglass core between a masonite skin with laminate and fiberglass with fabric.
- Product is UL 1286 listed.
- Panels are connected through single piece poly hinges.
- **Panel-to-Panel Power Connectors must be specified separately.**
- Powered panel raceway includes four locations for receptacles and cable access for panels wider than 24". 24" panel contains two receptacle locations. **12" and 18" wide panels are power pass through only.**

- Product includes complete panel assembly with connectors (panel, hinges, sleeve, side trim rails, top cap, base raceway).
- Specify ten-wire powered (T4) 442 system; nor ten-wire powered (T6) 622 system; or (TN) non-powered.
- Specify trim color.

To order (Example): CI-CPFL-2442-T4-BL-(XXX)-(XXX)  
 "Fabric/Laminate Acoustical Panel, 24-inch width, 42-inch height, ten-wire powered 442, black trim, (fabric color), (laminate color)."

Product	Width	Height
CI-CPFL-1232	12"	32"
CI-CPFL-1242	12"	42"
CI-CPFL-1248	12"	48"
CI-CPFL-1254	12"	54"
CI-CPFL-1262	12"	62"
CI-CPFL-1266	12"	66"
CI-CPFL-1272	12"	72"
CI-CPFL-1280	12"	80"
CI-CPFL-1832	18"	32"
CI-CPFL-1842	18"	42"
CI-CPFL-1848	18"	48"
CI-CPFL-1854	18"	54"
CI-CPFL-1862	18"	62"
CI-CPFL-1866	18"	66"
CI-CPFL-1872	18"	72"
CI-CPFL-1880	18"	80"
CI-CPFL-2432	24"	32"
CI-CPFL-2442	24"	42"
CI-CPFL-2448	24"	48"
CI-CPFL-2454	24"	54"
CI-CPFL-2462	24"	62"
CI-CPFL-2466	24"	66"
CI-CPFL-2472	24"	72"
CI-CPFL-2480	24"	80"
CI-CPFL-3032	30"	32"
CI-CPFL-3042	30"	42"
CI-CPFL-3048	30"	48"
CI-CPFL-3054	30"	54"
CI-CPFL-3062	30"	62"
CI-CPFL-3066	30"	66"
CI-CPFL-3072	30"	72"
CI-CPFL-3080	30"	80"
CI-CPFL-3632	36"	32"
CI-CPFL-3642	36"	42"
CI-CPFL-3648	36"	48"
CI-CPFL-3654	36"	54"

Product	Width	Height
CI-CPFL-3662	36"	62"
CI-CPFL-3666	36"	66"
CI-CPFL-3672	36"	72"
CI-CPFL-3680	36"	80"
CI-CPFL-4232	42"	32"
CI-CPFL-4242	42"	42"
CI-CPFL-4248	42"	48"
CI-CPFL-4254	42"	54"
CI-CPFL-4262	42"	62"
CI-CPFL-4266	42"	66"
CI-CPFL-4272	42"	72"
CI-CPFL-4280	42"	80"
CI-CPFL-4832	48"	32"
CI-CPFL-4842	48"	42"
CI-CPFL-4848	48"	48"
CI-CPFL-4854	48"	54"
CI-CPFL-4862	48"	62"
CI-CPFL-4866	48"	66"
CI-CPFL-4872	48"	72"
CI-CPFL-4880	48"	80"
CI-CPFL-5432	54"	32"
CI-CPFL-5442	54"	42"
CI-CPFL-5448	54"	48"
CI-CPFL-5454	54"	54"
CI-CPFL-5462	54"	62"
CI-CPFL-5466	54"	66"
CI-CPFL-5472	54"	72"
CI-CPFL-5480	54"	80"
CI-CPFL-6032	60"	32"
CI-CPFL-6042	60"	42"
CI-CPFL-6048	60"	48"
CI-CPFL-6054	60"	54"
CI-CPFL-6062	60"	62"
CI-CPFL-6066	60"	66"
CI-CPFL-6072	60"	72"
CI-CPFL-6080	60"	80"



# Panels

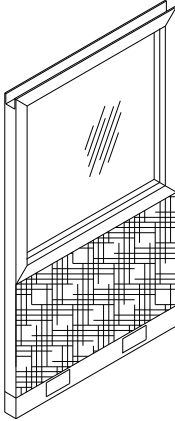

## Half Glass/Half Fabric Panels

- The top half of the panel is 1/4" clear or bronze tempered glass panel in a painted aluminum frame. The bottom half of the panel is constructed of a metal frame, aluminum septum and fiberglass between expanded metal, covered with fiberglass and fabric. Glass begins at 29" height.
- Product is UL1286 listed.
- Panels are connected through single piece poly hinges.
- **Panel-to-panel power connectors must be specified separately.**
- Powered panel raceway includes four locations for receptacles and cable access for panels wider than 24".
- 24" panel contains two receptacle locations.

- Product includes complete panel assembly with connectors (panel, hinges, sleeve, side trim rails, top cap, base raceway).
- Specify ten-wire powered (T4) 442 system; or ten-wire powered (T6) 622 system; or (TN) non-powered.
- Specify trim color.
- **Glass panels are available with clear or bronze glass. Add -SM to model # if requesting bronze glass (example) CI-CGFP-2454-SM-TN-BL.**

To order (Example):CI-CGFP-2454-TN-BL-(XXX)  
 "Half Glass/Half Fabric Panel, 24-inch width, 54-inch height, non-powered, black trim, (fabric color)."

Product	Width	Height
CI-CGFP-2454	24"	54"
CI-CGFP-2462	24"	62"
CI-CGFP-2466	24"	66"
CI-CGFP-2472	24"	72"
CI-CGFP-2480	24"	80"
CI-CGFP-3054	30"	54"
CI-CGFP-3062	30"	62"
CI-CGFP-3066	30"	66"
CI-CGFP-3072	30"	72"
CI-CGFP-3080	30"	80"
CI-CGFP-3654	36"	54"
CI-CGFP-3662	36"	62"

Product	Width	Height
CI-CGFP-3666	36"	66"
CI-CGFP-3672	36"	72"
CI-CGFP-3680	36"	80"
CI-CGFP-4254	42"	54"
CI-CGFP-4262	42"	62"
CI-CGFP-4266	42"	66"
CI-CGFP-4272	42"	72"
CI-CGFP-4280	42"	80"
CI-CGFP-4854	48"	54"
CI-CGFP-4862	48"	62"
CI-CGFP-4866	48"	66"
CI-CGFP-4872	48"	72"
CI-CGFP-4880	48"	80"

# Panels

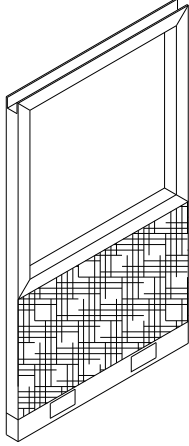

## Half Open Frame/Half Fabric Panels

- Half open frame/half fabric panel with fabric section on bottom, opening begins at 29" height. Bottom half of the panel is constructed of a metal frame, aluminum septum and fiberglass between expanded metal, covered with fiberglass and fabric. The top half of the panel is constructed of a painted aluminum frame.
- Product is UL1286 listed.
- Class A fire rated. Certain fabrics only.
- Half open panels are connected through single piece poly hinges.
- **Panel-to-panel power connectors must be specified separately.**
- Powered panel raceway includes four locations for receptacles and cable access for panels wider than 24".

- 24" panel contains two receptacle locations.
- Product includes complete panel assembly with connectors (panel, hinges, sleeves, side trim rails, top cap, base raceway).
- Specify ten-wire powered (T4) 442 system; or ten-wire powered (T6) 622 system; or (TN) non-powered.
- Specify trim color.

To order (Example): CI-COFP-2454-TN-BL-(XXX)  
 "Half Open Frame/Half Fabric Panel, 24-inch width, 54-inch height, non-powered, black trim, (fabric color)."

Product	Width	Height
CI-COFP-2454	24"	54"
CI-COFP-2462	24"	62"
CI-COFP-2466	24"	66"
CI-COFP-2472	24"	72"
CI-COFP-2480	24"	80"
CI-COFP-3054	30"	54"
CI-COFP-3062	30"	62"
CI-COFP-3066	30"	66"
CI-COFP-3072	30"	72"
CI-COFP-3080	30"	80"
CI-COFP-3654	36"	54"
CI-COFP-3662	36"	62"
CI-COFP-3666	36"	66"
CI-COFP-3672	36"	72"
CI-COFP-3680	36"	80"

Product	Width	Height
CI-COFP-4254	42"	54"
CI-COFP-4262	42"	62"
CI-COFP-4266	42"	66"
CI-COFP-4272	42"	72"
CI-COFP-4280	42"	80"
CI-COFP-4854	48"	54"
CI-COFP-4862	48"	62"
CI-COFP-4866	48"	66"
CI-COFP-4872	48"	72"
CI-COFP-4880	48"	80"

# Panels

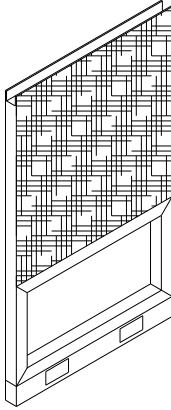

## Bottom Open Frame Panels

- Used when panels will cover items on the building wall that need to be accessed (Heating/AC, Data and Electrical boxes).
- Bottom open frame panel with open section at bottom of panel in varying heights determined by panel height. The bottom of the panel is a painted aluminum frame. The top of the panel is constructed of a metal frame, aluminum septum and fiberglass between expanded metal, covered with fiberglass and fabric.
- Product is UL1286 listed.
- Bottom open frame panels are connected through single piece poly hinges.
- **Panel-to-Panel Power Connectors must be specified separately.**
- Powered panel raceway includes four locations for receptacles and cable access for panels wider than 24".
- 24" panel contains two receptacle locations.
- Product includes complete panel assembly with connectors (panel, hinges, sleeves, side trim rails, top cap, base raceway).
- Specify ten-wire powered (T4) 442 system; or ten-wire powered (T6) 622 system; or (TN) non-powered.
- Specify trim color.

To order (Example): CI-BOFP-3666-T4-BL-(XXX)  
 "Bottom Open Frame Panel, 36-inch width, 66-inch height, ten-wire powered 442, black trim, (fabric color)."

Product	Width	Height
CI-BOFP-2442	24"	42"
CI-BOFP-2448	24"	48"
CI-BOFP-2454	24"	54"
CI-BOFP-2462	24"	62"
CI-BOFP-2466	24"	66"
CI-BOFP-2472	24"	72"
CI-BOFP-2480	24"	80"
CI-BOFP-3042	30"	42"
CI-BOFP-3048	30"	48"
CI-BOFP-3054	30"	54"
CI-BOFP-3062	30"	62"
CI-BOFP-3066	30"	66"
CI-BOFP-3072	30"	72"
CI-BOFP-3080	30"	80"
CI-BOFP-3642	36"	42"
CI-BOFP-3648	36"	48"
CI-BOFP-3654	36"	54"
CI-BOFP-3662	36"	62"
CI-BOFP-3666	36"	66"
CI-BOFP-3672	36"	72"
CI-BOFP-3680	36"	80"
CI-BOFP-4242	42"	42"
CI-BOFP-4248	42"	48"
CI-BOFP-4254	42"	54"
CI-BOFP-4262	42"	62"

Product	Width	Height
CI-BOFP-4266	42"	66"
CI-BOFP-4272	42"	72"
CI-BOFP-4280	42"	80"
CI-BOFP-4842	48"	42"
CI-BOFP-4848	48"	48"
CI-BOFP-4854	48"	54"
CI-BOFP-4862	48"	62"
CI-BOFP-4866	48"	66"
CI-BOFP-4872	48"	72"
CI-BOFP-4880	48"	80"
CI-BOFP-5442	54"	42"
CI-BOFP-5448	54"	48"
CI-BOFP-5454	54"	54"
CI-BOFP-5462	54"	62"
CI-BOFP-5466	54"	66"
CI-BOFP-5472	54"	72"
CI-BOFP-5480	54"	80"
CI-BOFP-6042	60"	42"
CI-BOFP-6048	60"	48"
CI-BOFP-6054	60"	54"
CI-BOFP-6062	60"	62"
CI-BOFP-6066	60"	66"
CI-BOFP-6072	60"	72"
CI-BOFP-6080	60"	80"

# Panels

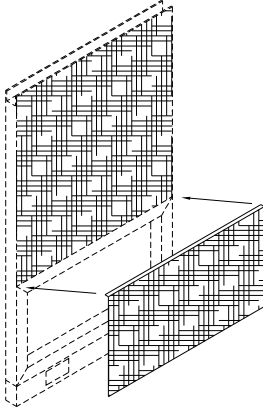

## Bottom Open Frame Panel Covers

- Cover is formed steel covered with fabric.
- Cover is held in place by a hanging flange and hook and loop patches.
- Cover is designed to give a bottom open frame panel the look of a fabric acoustic panel. Removing the cover allows access to areas behind the open frame panel (wall or column elec. or comm. boxes).

To order (Example): CI-BOFC-3624-(XXX)  
 "Bottom open frame cover for 36" wide 24" high for a 66". Bottom open frame panel (fabric color)."

Product	Width	Height	Fits BOFP Panel Height
CI-BOFC-0616	6"	16"	48"
CI-BOFC-2416	24"	16"	48"
CI-BOFC-3016	30"	16"	48"
CI-BOFC-3616	36"	16"	48"
CI-BOFC-4216	42"	16"	48"
CI-BOFC-4816	48"	16"	48"
CI-BOFC-5416	54"	16"	48"
CI-BOFC-6016	60"	16"	48"
CI-BOFC-0618	6"	18"	42"
CI-BOFC-2418	24"	18"	42"
CI-BOFC-3018	30"	18"	42"
CI-BOFC-3618	36"	18"	42"
CI-BOFC-4218	42"	18"	42"
CI-BOFC-4818	48"	18"	42"
CI-BOFC-5418	54"	18"	42"
CI-BOFC-6018	60"	18"	42"
CI-BOFC-0620	6"	20"	62"
CI-BOFC-2420	24"	20"	62"
CI-BOFC-3020	30"	20"	62"
CI-BOFC-3620	36"	20"	62"
CI-BOFC-4220	42"	20"	62"
CI-BOFC-4820	48"	20"	62"
CI-BOFC-5420	54"	20"	62"
CI-BOFC-6020	60"	20"	62"

Product	Width	Height	Fits BOFP Panel Height
CI-BOFC-0621	6"	21"	54"
CI-BOFC-2421	24"	21"	54"
CI-BOFC-3021	30"	21"	54"
CI-BOFC-3621	36"	21"	54"
CI-BOFC-4221	42"	21"	54"
CI-BOFC-4821	48"	21"	54"
CI-BOFC-5421	54"	21"	54"
CI-BOFC-6021	60"	21"	54"
CI-BOFC-0624	6"	24"	66"/72"
CI-BOFC-2424	24"	24"	66"/72"
CI-BOFC-3024	30"	24"	66"/72"
CI-BOFC-3624	36"	24"	66"/72"
CI-BOFC-4224	42"	24"	66"/72"
CI-BOFC-4824	48"	24"	66"/72"
CI-BOFC-5424	54"	24"	66"/72"
CI-BOFC-6024	60"	24"	66"/72"
CI-BOFC-0626	6"	26"	80"
CI-BOFC-2426	24"	26"	80"
CI-BOFC-3026	30"	26"	80"
CI-BOFC-3626	36"	26"	80"
CI-BOFC-4226	42"	26"	80"
CI-BOFC-4826	48"	26"	80"
CI-BOFC-5426	54"	26"	80"
CI-BOFC-6026	60"	26"	80"

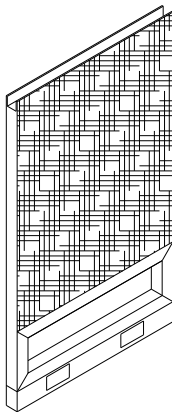

## Special Bottom Open Frame Panels - 7" Opening

- Bottom open frame panel with 7" high open section.
- The bottom of the panel is a painted aluminum frame. The top of the panel is constructed of a metal frame, aluminum septum and fiberglass between expanded metal, covered with fiberglass and fabric.
- Product is UL1286 listed.
- Bottom open frame panels are connected through single piece poly hinges.
- **Panel-to-Panel Power Connectors must be specified separately.**
- Powered panel raceway includes four locations for receptacles and cable access for panels wider than 24". 24" panel contains two receptacle locations. **12" and 18" wide panels are power pass through only.**

- Product includes complete panel assembly with connectors (panel, hinges, sleeves, side trim rails, top cap, base raceway).
- Specify ten-wire powered (T4) 442 system; or ten-wire powered (T6) 622 system; or (TN) non-powered.
- Specify trim color.

To order (Example): CI-SBOFP-3666-T4-BL-(XXX)  
 "Special Bottom Open Frame Panel, 36-inch width, 66-inch height, 10-wired powered 442, black trim, (fabric color)."

Product	Width	Height
CI-SBOFP-1854	18"	54"
CI-SBOFP-1866	18"	66"
CI-SBOFP-2454	24"	54"
CI-SBOFP-2466	24"	66"
CI-SBOFP-3054	30"	54"
CI-SBOFP-3066	30"	66"
CI-SBOFP-3654	36"	54"

Product	Width	Height
CI-SBOFP-3666	36"	66"
CI-SBOFP-4254	42"	54"
CI-SBOFP-4266	42"	66"
CI-SBOFP-4854	48"	54"
CI-SBOFP-4866	48"	66"
CI-SBOFP-6054	60"	54"
CI-SBOFP-6066	60"	66"

# Panels

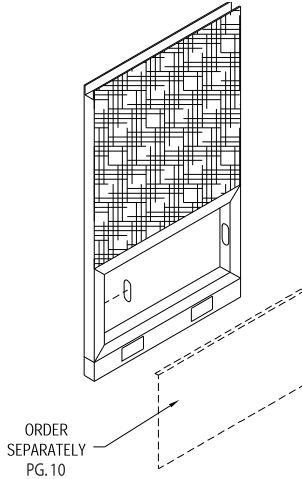

## Bottom Open Frame Panels

### With Access Openings

- Bottom open frame panel with open section at bottom of panel in varying heights determined by panel height.
- **The two vertical open frame members each have a 1½" x 3¾" oval access openings located at the vertical center line of the frame member (see drawing).** Access opening allows data/comm. cables to be routed from a wall plate or box directly into the panel vertical wireway. Access opening on opposite frame member can be used to internally feed electrical power into the panel by **separately ordering** a top feed electrical harness.
- Panel is used when the 3" space required for a electrical basefeed is not available between the panel and a building wall, or when access is required to the electrical and data/comm. junction boxes that are located on a building column or wall.
- Order a Bottom Open Frame Cover separately to prevent cables from being exposed in the open area.
- The bottom of the panel is a painted aluminum frame. The top of the panel is constructed of a metal frame, aluminum septum and fiberglass between expanded metal, covered with fiberglass and fabric.

- Product is UL1286 listed.
- Bottom open frame panels are connected through single piece poly hinges.
- **Panel-to-Panel Power Connectors must be specified separately.**
- Powered panel raceway includes four locations for receptacles and cable access for panels wider than 24". 24" panel contains two receptacle locations.
- Product includes complete panel assembly with connectors (panel, hinges, sleeves, side trim rails, top cap, base raceway).
- Specify ten-wire powered (T4) 442 system; or ten-wire powered (T6) 622 system; or (TN) non-powered.
- Specify trim color.

To order (Example): CI-BOFPA-3666-T6-BL-(XXX)  
 "Bottom Open Frame Panel with Access Opening,  
 36-inch width, 66-inch height, ten-wire powered 622,  
 black trim, (fabric color)."

Product	Width	Height
CI-BOFPA-2442	24"	42"
CI-BOFPA-2448	24"	48"
CI-BOFPA-2454	24"	54"
CI-BOFPA-2462	24"	62"
CI-BOFPA-2466	24"	66"
CI-BOFPA-2472	24"	72"
CI-BOFPA-2480	24"	80"
CI-BOFPA-3042	30"	42"
CI-BOFPA-3048	30"	48"
CI-BOFPA-3054	30"	54"
CI-BOFPA-3062	30"	62"
CI-BOFPA-3066	30"	66"
CI-BOFPA-3072	30"	72"
CI-BOFPA-3080	30"	80"
CI-BOFPA-3642	36"	42"
CI-BOFPA-3648	36"	48"
CI-BOFPA-3654	36"	54"
CI-BOFPA-3662	36"	62"
CI-BOFPA-3666	36"	66"
CI-BOFPA-3672	36"	72"
CI-BOFPA-3680	36"	80"
CI-BOFPA-4242	42"	42"
CI-BOFPA-4248	42"	48"
CI-BOFPA-4254	42"	54"
CI-BOFPA-4262	42"	62"

Product	Width	Height
CI-BOFPA-4266	42"	66"
CI-BOFPA-4272	42"	72"
CI-BOFPA-4280	42"	80"
CI-BOFPA-4842	48"	42"
CI-BOFPA-4848	48"	48"
CI-BOFPA-4854	48"	54"
CI-BOFPA-4862	48"	62"
CI-BOFPA-4866	48"	66"
CI-BOFPA-4872	48"	72"
CI-BOFPA-4880	48"	80"
CI-BOFPA-5442	54"	42"
CI-BOFPA-5448	54"	48"
CI-BOFPA-5454	54"	54"
CI-BOFPA-5462	54"	62"
CI-BOFPA-5466	54"	66"
CI-BOFPA-5472	54"	72"
CI-BOFPA-5480	54"	80"
CI-BOFPA-6042	60"	42"
CI-BOFPA-6048	60"	48"
CI-BOFPA-6054	60"	54"
CI-BOFPA-6062	60"	62"
CI-BOFPA-6066	60"	66"
CI-BOFPA-6072	60"	72"
CI-BOFPA-6080	60"	80"

# Panels

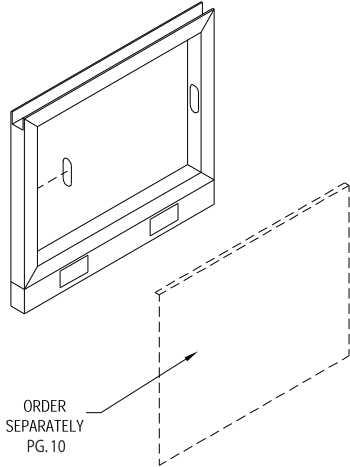

## Open Frame Panels With Access Openings

- Panel is constructed of a painted aluminum frame.
- **The two vertical open frame members each have a 1½" x 3½" oval access openings located at the vertical center line of the frame member (see drawing).** Access opening allows data/comm. cables to be routed from a wall plate or box directly into the panel vertical wireway. Access opening on opposite frame member can be used to internally feed electrical power into the panel by **separately ordering** a top feed electrical harness.
- Panel is used when the 3" space required for an electrical basefeed is not available between the panel and a building wall, or when access is required to the electrical and data/comm. junction boxes that are located on a building column or wall.
- Order an Open Frame Cover separately to prevent cables from being exposed in the open area.
- Panels are connected through single piece poly hinges.
- **Panel-to-Panel Power Connectors must be specified separately.**
- Powered panel raceway includes four locations for receptacles and cable access for panels wider than 24". 24" panel contains two receptacle locations.
- Product includes complete panel assembly with connectors (panel, hinges, sleeve, side trim rails, top cap, base raceway).
- Specify ten-wire powered (T4) 442 system; or ten-wire powered (T6) 622 system; or (TN) non-powered.
- Specify trim color.

To order (Example): CI-OFPA-2442-T4-BL  
 "Open Frame Panel with Access Opening, 24-inch width, 42-inch height, ten-wire powered 442, black trim."

Product	Width	Height
CI-OFPA-2432	24"	32"
CI-OFPA-3032	30"	32"
CI-OFPA-3632	36"	32"

Product	Width	Height
CI-OFPA-4232	42"	32"
CI-OFPA-4832	48"	32"

# Curved Panels

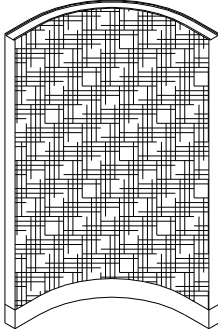

## Curved Fabric Panels

- Curved panels provide a radiused panel to replace two 24" straight panels.
- Panel is constructed of a metal and wood frame, fiberglass core covered with fiberglass and fabric.
- Product is UL 1286 listed.
- Panels are connected through single piece poly hinges.
- Product includes complete panel assembly with connectors (panel, hinges, side trim rails, top cap, base raceway).
- **Powered panel provides pass-through capabilities only.**

- Specify ten-wire powered (T4) 442 system; or ten-wire powered (T6) 622 system; or (TN) non-powered.
- Specify trim color.

To order (Example): CI-CP-42C-T4-GR-(XXX)  
 "Curved Fabric Panel, 42-inch height, ten-wire powered 442, blue grey trim, (fabric color number)."

Product	Width	Height
CI-CP-32C	24"	32"
CI-CP-42C	24"	42"
CI-CP-48C	24"	48"
CI-CP-54C	24"	54"

Product	Width	Height
CI-CP-62C	24"	62"
CI-CP-66C	24"	66"
CI-CP-72C	24"	72"
CI-CP-80C	24"	80"

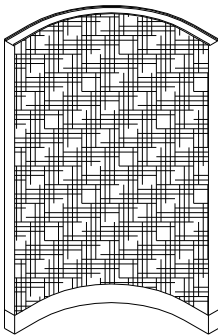

## Curved Fabric/Laminate Panels

- Panel is constructed of a metal and wood frame, and fiberglass core covered with masonite and laminate, or fiberglass and fabric.
- Product is UL 1286 listed.
- Panels are connected through single piece poly hinges.
- Product includes complete panel assembly with connectors (panel, hinges, side trim rails, top cap, base raceway).
- **Powered panel provides pass-through capabilities only.**

- Specify ten-wire powered (T4) 442 system; or ten-wire powered (T6) 622 system; or (TN) non-powered.
- Specify trim color.
- **Laminate surface is on the "outside curve" of the panel.**

To order (Example): CI-CPFL-42C-T4-GR-(XXX)-(XXX)  
 "Curved Fabric Laminate Panel, 42-inch height, ten-wire powered 442, blue grey trim, (fabric color) and (laminate number)."

Product	Width	Height
CI-CPFL-32C	24"	32"
CI-CPFL-42C	24"	42"
CI-CPFL-48C	24"	48"
CI-CPFL-54C	24"	54"

Product	Width	Height
CI-CPFL-62C	24"	62"
CI-CPFL-66C	24"	66"
CI-CPFL-72C	24"	72"
CI-CPFL-80C	24"	80"

# ERP Panels

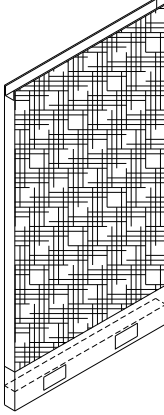

## ERP Fabric Acoustical Panels

- Panel is constructed of a metal frame, aluminum septum and fiberglass between expanded metal, covered with fiberglass and fabric.
- 8" panel raceway features a 4" tall wireway that houses the electrical harness on powered panels and a 4" tall wireway for routing of data/comm. cables. The two wireways are separated by a continuous steel septum.
- Product is UL 1286 listed.
- Class A fire rated. Certain fabrics only.
- Panels are connected through single piece poly hinges.
- **Panel-to-Panel Power Connectors must be specified separately.**
- Powered panel raceway includes four locations for receptacles for panels wider than 24 inches. 24" panel contains two receptacle locations.  
**12" and 18" wide panels are power pass through only.**
- Product includes complete panel assembly with connectors (panel, hinges, sleeve, side trimrails, top cap, base raceway).
- ERP panels are compatible with standard System XXI panels.
- Specify ten-wire powered (T4) 442 system; or ten-wire powered (T6) 622 system; or (TN) non-powered.
- Specify trim color.

To order (Example): CI-EFP-2458-T4-BL-(XXX)  
"ERP Fabric Acoustical Panel, 24" width, 58" height, ten-wire powered 442, black trim, (fabric color)."

Product	Width	Height
CI-EFP-1236	12"	36"
CI-EFP-1246	12"	46"
CI-EFP-1252	12"	52"
CI-EFP-1258	12"	58"
CI-EFP-1266	12"	66"
CI-EFP-1270	12"	70"
CI-EFP-1276	12"	76"
CI-EFP-1284	12"	84"
CI-EFP-1836	18"	36"
CI-EFP-1846	18"	46"
CI-EFP-1852	18"	52"
CI-EFP-1858	18"	58"
CI-EFP-1866	18"	66"
CI-EFP-1870	18"	70"
CI-EFP-1876	18"	76"
CI-EFP-1884	18"	84"
CI-EFP-2436	24"	36"
CI-EFP-2446	24"	46"
CI-EFP-2452	24"	52"
CI-EFP-2458	24"	58"
CI-EFP-2466	24"	66"
CI-EFP-2470	24"	70"
CI-EFP-2476	24"	76"
CI-EFP-2484	24"	84"
CI-EFP-3036	30"	36"
CI-EFP-3046	30"	46"
CI-EFP-3052	30"	52"
CI-EFP-3058	30"	58"
CI-EFP-3066	30"	66"
CI-EFP-3070	30"	70"
CI-EFP-3076	30"	76"
CI-EFP-3084	30"	84"
CI-EFP-3636	36"	36"
CI-EFP-3646	36"	46"
CI-EFP-3652	36"	52"
CI-EFP-3658	36"	58"

Product	Width	Height
CI-EFP-3666	36"	66"
CI-EFP-3670	36"	70"
CI-EFP-3676	36"	76"
CI-EFP-3684	36"	84"
CI-EFP-4236	42"	36"
CI-EFP-4246	42"	46"
CI-EFP-4252	42"	52"
CI-EFP-4258	42"	58"
CI-EFP-4266	42"	66"
CI-EFP-4270	42"	70"
CI-EFP-4276	42"	76"
CI-EFP-4284	42"	84"
CI-EFP-4836	48"	36"
CI-EFP-4846	48"	46"
CI-EFP-4852	48"	52"
CI-EFP-4858	48"	58"
CI-EFP-4866	48"	66"
CI-EFP-4870	48"	70"
CI-EFP-4876	48"	76"
CI-EFP-4884	48"	84"
CI-EFP-5436	54"	36"
CI-EFP-5446	54"	46"
CI-EFP-5452	54"	52"
CI-EFP-5458	54"	58"
CI-EFP-5466	54"	66"
CI-EFP-5470	54"	70"
CI-EFP-5476	54"	76"
CI-EFP-5484	54"	84"
CI-EFP-6036	60"	36"
CI-EFP-6046	60"	46"
CI-EFP-6052	60"	52"
CI-EFP-6058	60"	58"
CI-EFP-6066	60"	66"
CI-EFP-6070	60"	70"
CI-EFP-6076	60"	76"
CI-EFP-6084	60"	84"



# ERP Panels

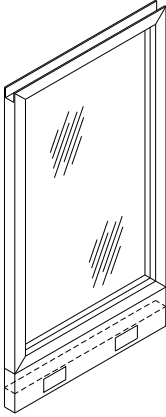

## ERP Glass Panels

- Painted aluminum frame with 1/4" clear or bronze tempered glass.
- 8" panel raceway features a 4" tall wireway that houses the electrical harness on powered panels and a 4" tall wireway for routing of data/comm. cables. The two wireways are separated by a continuous steel septum.
- Product is UL 1286 listed.
- Panels are connected through single piece poly hinges.
- **Panel-to-Panel Power Connectors must be specified separately.**
- Powered panel raceway includes four locations for receptacles for panels wider than 24". 24" panel contains two receptacle locations.  
**12" and 18" wide panels are power pass through only.**
- Product includes complete panel assembly with connectors (panel, hinges, sleeve, side trim rails, top cap, base raceway).
- ERP panels are compatible with standard System XXI panels.
- Specify ten-wire powered (T4) 442 system; or ten-wire powered (T6) 622 system; or (TN) non-powered.
- Specify trim color.
- **Glass panels are available with clear or bronze glass. Add -SM to model # if requesting bronze glass (example) CI-EGP-4870-SM.**

To order (Example): CI-EGP-2470-TN-SA  
"ERP Glass Panel 24 inch width, 70 inch height, non-powered, sand trim."

Product	Width	Height
CI-EGP-1252	12"	52"
CI-EGP-1258	12"	58"
CI-EGP-1266	12"	66"
CI-EGP-1270	12"	70"
CI-EGP-1276	12"	76"
CI-EGP-1284	12"	84"
CI-EGP-1852	18"	52"
CI-EGP-1858	18"	58"
CI-EGP-1866	18"	66"
CI-EGP-1870	18"	70"
CI-EGP-1876	18"	76"
CI-EGP-1884	18"	84"
CI-EGP-2452	24"	52"
CI-EGP-2458	24"	58"
CI-EGP-2466	24"	66"
CI-EGP-2470	24"	70"
CI-EGP-2476	24"	76"
CI-EGP-2484	24"	84"
CI-EGP-3052	30"	52"
CI-EGP-3058	30"	58"
CI-EGP-3066	30"	66"

Product	Width	Height
CI-EGP-3070	30"	70"
CI-EGP-3076	30"	76"
CI-EGP-3084	30"	84"
CI-EGP-3652	36"	52"
CI-EGP-3658	36"	58"
CI-EGP-3666	36"	66"
CI-EGP-3670	36"	70"
CI-EGP-3676	36"	76"
CI-EGP-3684	36"	84"
CI-EGP-4246	42"	46"
CI-EGP-4252	42"	52"
CI-EGP-4258	42"	58"
CI-EGP-4266	42"	66"
CI-EGP-4270	42"	70"
CI-EGP-4276	42"	76"
CI-EGP-4284	42"	84"
CI-EGP-4852	48"	52"
CI-EGP-4858	48"	58"
CI-EGP-4866	48"	66"
CI-EGP-4870	48"	70"
CI-EGP-4876	48"	76"
CI-EGP-4884	48"	84"

# ERP Panels

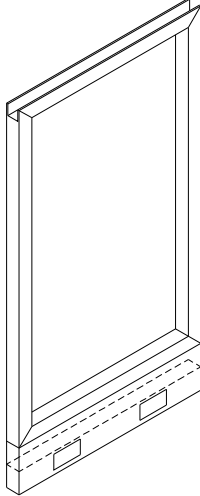

## ERP Open Frame Panels

- Panel is constructed of a painted aluminum frame.
- 8" panel raceway features a 4" tall wireway that houses the electrical harness on powered panels and a 4" tall wireway for routing of data/comm. cables. The two wireways are separated by a continuous steel septum.
- Product is UL 1286 listed.
- Panels are connected through single piece poly hinges.
- **Panel-to-Panel Power Connectors must be specified separately.**
- Powered panel raceway includes four locations for receptacles for panels wider than 24". 24" panel contains two receptacle locations.

**12" and 18" wide panels are power pass through only.**

- Product includes complete panel assembly with connectors (panel, hinges, sleeve, side trimrails, top cap, base raceway).
- ERP panels are compatible with standard System XXI panels.
- Specify ten-wire powered (T4) 442 system; or ten-wire powered (T6) 622 system; or (TN) non-powered.
- Specify trim color.

To order (Example): CI-EOFP-3046-T4-GR  
 "ERP Open Frame Panel, 30 inch width, 46 inch height, ten-wire powered 442, blue grey trim."

Product	Width	Height
CI-EOFP-2436	24"	36"
CI-EOFP-2446	24"	46"
CI-EOFP-2452	24"	52"
CI-EOFP-3036	30"	36"
CI-EOFP-3046	30"	46"
CI-EOFP-3052	30"	52"
CI-EOFP-3636	36"	36"
CI-EOFP-3646	36"	46"

Product	Width	Height
CI-EOFP-3652	36"	52"
CI-EOFP-4236	42"	36"
CI-EOFP-4246	42"	46"
CI-EOFP-4252	42"	52"
CI-EOFP-4836	48"	36"
CI-EOFP-4846	48"	46"
CI-EOFP-4852	48"	52"

# ERP Panels

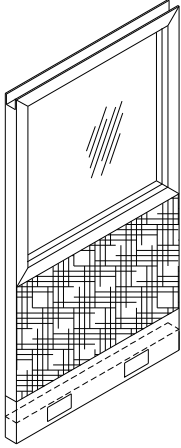

## ERP Half Glass/Half Fabric Panels

- 1/4" clear or bronze tempered glass panels with glass beginning at 33" height.
- The top half of the panel is 1/4" clear or bronze tempered glass panel in a painted aluminum frame. The bottom half of the panel is constructed of a metal frame, aluminum septum and fiberglass between expanded metal, covered with fiberglass and fabric. Glass begins at 29" height.
- 8" panel raceway features a 4" tall wireway that houses the electrical harness on powered panels and a 4" tall wireway for routing of data/comm. cables. The two wireways are separated by a continuous steel septum.
- Product is UL 1286 listed.
- Panels are connected through single piece poly hinges.
- **Panel-to-Panel Power Connectors must be specified separately.**
- Powered panel raceway includes four locations for receptacles for panels wider than 24". 24" panel contains two receptacle locations.

- Product includes complete panel assembly with connectors (panel, hinges, sleeve, side trim rails, top cap, base raceway).
- ERP panels are compatible with standard System XXI panels.
- Specify ten-wire powered (T4) 442 system; or ten-wire powered (T6) 622 system; or (TN) non-powered.
- Specify trim color.
- **Glass panels are available with clear or bronze glass. Add -SM to model # if requesting bronze glass (example) CI-EGFP-2458-SM.**

To order (Example): CI-EGFP-2458-TN-BL-(XXX)  
 "ERP Half Glass/Half Fabric Panel, 24 inch width 58 inch height, non-powered, black trim, (fabric color #)."

Product	Width	Height
CI-EGFP-2452	24"	52"
CI-EGFP-2458	24"	58"
CI-EGFP-2466	24"	66"
CI-EGFP-2470	24"	70"
CI-EGFP-2476	24"	76"
CI-EGFP-2484	24"	84"
CI-EGFP-3052	30"	52"
CI-EGFP-3058	30"	58"
CI-EGFP-3066	30"	66"
CI-EGFP-3070	30"	70"
CI-EGFP-3076	30"	76"
CI-EGFP-3084	30"	84"
CI-EGFP-3652	36"	52"
CI-EGFP-3658	36"	58"
CI-EGFP-3666	36"	66"

Product	Width	Height
CI-EGFP-3670	36"	70"
CI-EGFP-3676	36"	76"
CI-EGFP-3684	36"	84"
CI-EGFP-4252	42"	52"
CI-EGFP-4258	42"	58"
CI-EGFP-4266	42"	66"
CI-EGFP-4270	42"	70"
CI-EGFP-4276	42"	76"
CI-EGFP-4284	42"	84"
CI-EGFP-4852	48"	52"
CI-EGFP-4858	48"	58"
CI-EGFP-4866	48"	66"
CI-EGFP-4870	48"	70"
CI-EGFP-4876	48"	76"
CI-EGFP-4884	48"	84"

# ERP Panels

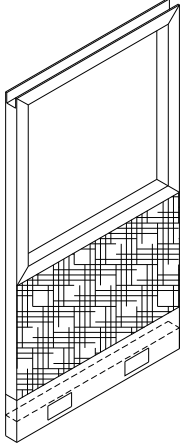

## ERP Half Open Frame/Half Fabric Panels

- Half open frame/half fabric panel with open area beginning at 33" height.
- Half open frame/half fabric panel with fabric section on bottom, opening begins at 29" height. Bottom half of the panel is constructed of a metal frame, aluminum septum and fiberglass between expanded metal, covered with fiberglass and fabric. The top half of the panel is constructed of a painted aluminum frame.
- 8" panel raceway features a 4" tall wireway that houses the electrical harness on powered panels and a 4" tall wireway for routing of data/comm. cables. The two wireways are separated by a continuous steel septum.
- Product is UL 1286 listed.
- Class A fire rated. Certain fabrics only.
- Panels are connected through single piece poly hinges.
- **Panel-to-Panel Power Connectors must be specified separately.**

- Powered panel raceway includes four locations for receptacles for panels wider than 24". 24" panel contains two receptacle locations.
- Product includes complete panel assembly with connectors (panel, hinges, sleeve, side trim rails, top cap, base raceway).
- ERP panels are compatible with standard System XXI panels.
- Specify ten-wire powered (T4) 442 system; or ten-wire powered (T6) 622 system; or (TN) non-powered.
- Specify trim color.

To order (Example): CI-ECOFP-2484-T6-BL-(XXX)  
 "ERP Half Open/Half Fabric Panel, 24 inch width, 84 inch height, ten-wire powered 622, black trim (fabric color #)."

Product	Width	Height
CI-ECOFP-2452	24"	52"
CI-ECOFP-2458	24"	58"
CI-ECOFP-2466	24"	66"
CI-ECOFP-2470	24"	70"
CI-ECOFP-2476	24"	76"
CI-ECOFP-2484	24"	84"
CI-ECOFP-3052	30"	52"
CI-ECOFP-3058	30"	58"
CI-ECOFP-3066	30"	66"
CI-ECOFP-3070	30"	70"
CI-ECOFP-3076	30"	76"
CI-ECOFP-3084	30"	84"
CI-ECOFP-3652	36"	52"
CI-ECOFP-3658	36"	58"
CI-ECOFP-3666	36"	66"
CI-ECOFP-3670	36"	70"
CI-ECOFP-3676	36"	76"
CI-ECOFP-3684	36"	84"
CI-ECOFP-4252	42"	52"
CI-ECOFP-4258	42"	58"
CI-ECOFP-4266	42"	66"

Product	Width	Height
CI-ECOFP-4270	42"	70"
CI-ECOFP-4276	42"	76"
CI-ECOFP-4284	42"	84"
CI-ECOFP-4852	48"	52"
CI-ECOFP-4858	48"	58"
CI-ECOFP-4866	48"	66"
CI-ECOFP-4870	48"	70"
CI-ECOFP-4876	48"	76"
CI-ECOFP-4884	48"	84"

# ERP Panels

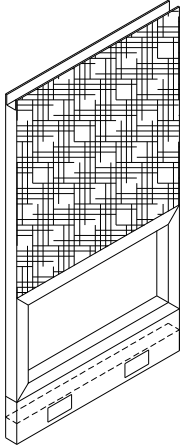

## ERP Bottom Open Frame Panels

- Used when panels will cover items on the building wall that need to be accessed (Heating/AC, Data and Electrical boxes).
- Bottom open frame panel with open section at bottom of panel in varying heights determined by panel height. The bottom of the panel is a painted aluminum frame. The top of the panel is constructed of a metal frame, aluminum septum and fiberglass between expanded metal, covered with fiberglass and fabric.
- 8" panel raceway features a 4" tall wireway that houses the electrical harness on powered panels and a 4" tall wireway for routing of data/comm. cables. The two wireways are separated by a continuous steel septum.
- Product is UL 1286 listed.
- Panels are connected through single piece poly hinges.
- **Panel-to-Panel Power Connectors must be specified separately.**
- Powered panel raceway includes four locations for receptacles for panels wider than 24". 24" panel contains two receptacle locations.
- Product includes complete panel assembly with connectors (panel, hinges, sleeve, side trim rails, top cap, base raceway).
- ERP panels are compatible with standard System XXI panels.
- Specify ten-wire powered (T4) 442 system; or ten-wire powered (T6) 622 system; or (TN) non-powered.
- Specify trim color.
- Standard Bottom Open Frame Panel Covers (CI-BOFC-SIZE) may be used on these panels. (Use the cover for a standard BOFP that is 4" shorter than the ERP height.)

To order (Example): CI-EBOFP-3666-T4-WG-(XXX)  
"ERP Bottom Open Frame Panel, 36 inch width, 66 inch height, ten-wire powered 442 warm grey trim, (fabric color #)."

Product	Width	Height
CI-EBOFP-2446	24"	46"
CI-EBOFP-2452	24"	52"
CI-EBOFP-2458	24"	58"
CI-EBOFP-2466	24"	66"
CI-EBOFP-2470	24"	70"
CI-EBOFP-2476	24"	76"
CI-EBOFP-2484	24"	84"
CI-EBOFP-3046	30"	46"
CI-EBOFP-3052	30"	52"
CI-EBOFP-3058	30"	58"
CI-EBOFP-3066	30"	66"
CI-EBOFP-3070	30"	70"
CI-EBOFP-3076	30"	76"
CI-EBOFP-3084	30"	84"
CI-EBOFP-3646	36"	46"
CI-EBOFP-3652	36"	52"
CI-EBOFP-3658	36"	58"
CI-EBOFP-3666	36"	66"
CI-EBOFP-3670	36"	70"
CI-EBOFP-3676	36"	76"
CI-EBOFP-3684	36"	84"
CI-EBOFP-4246	42"	46"
CI-EBOFP-4252	42"	52"
CI-EBOFP-4258	42"	58"
CI-EBOFP-4266	42"	66"

Product	Width	Height
CI-EBOFP-4270	42"	70"
CI-EBOFP-4276	42"	76"
CI-EBOFP-4284	42"	84"
CI-EBOFP-4846	48"	46"
CI-EBOFP-4852	48"	52"
CI-EBOFP-4858	48"	58"
CI-EBOFP-4866	48"	66"
CI-EBOFP-4870	48"	70"
CI-EBOFP-4876	48"	76"
CI-EBOFP-4884	48"	84"
CI-EBOFP-5446	54"	46"
CI-EBOFP-5452	54"	52"
CI-EBOFP-5458	54"	58"
CI-EBOFP-5466	54"	66"
CI-EBOFP-5470	54"	70"
CI-EBOFP-5476	54"	76"
CI-EBOFP-5484	54"	84"
CI-EBOFP-6046	60"	46"
CI-EBOFP-6052	60"	52"
CI-EBOFP-6058	60"	58"
CI-EBOFP-6066	60"	66"
CI-EBOFP-6070	60"	70"
CI-EBOFP-6076	60"	76"
CI-EBOFP-6084	60"	84"

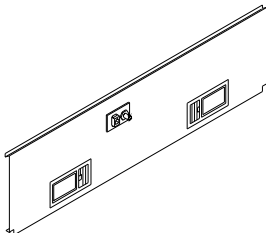

## ERP Data 1 810 Universal Raceway Cover

- A powered ERP raceway cover with the standard powered raceway receptacle bezels, and (1) data plate opening for (1) data faceplate.
- Sizes available 24-60.
- Opening is located to the left of center on the cover, in the top half of the cover.
- Data faceplates and modular jacks must be ordered separately from appropriate supplier.
- Specify trim color.

To order (Example): 47-0592-24-BL  
"ERP Data 1 powered Raceway Cover, 24" length, black."

### Product

47-0592-Size

# Panel Trim

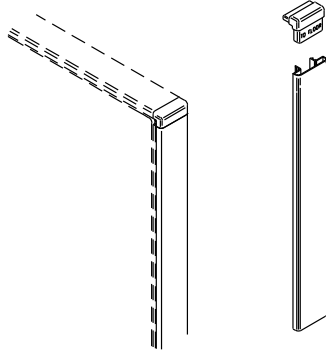

## Panel End Caps

- Extruded plastic cap covers panel end.
- Includes transition cap to top cap.
- Specify trim color.

To order (Example): CI-ECP-42-GR  
 "Panel End Cap, 42-inch height, blue grey trim."

Product	Width	Height	Depth
CI-ECP-32	2½"	32"	1"
CI-ECP-42	2½"	42"	1"
CI-ECP-48	2½"	48"	1"
CI-ECP-54	2½"	54"	1"
CI-ECP-62	2½"	62"	1"
CI-ECP-66	2½"	66"	1"
CI-ECP-72	2½"	72"	1"
CI-ECP-80	2½"	80"	1"

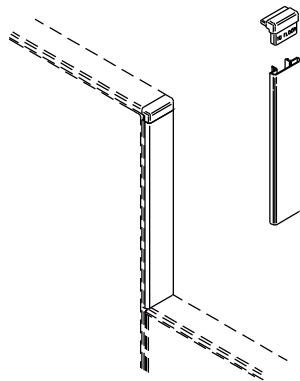

## In-Line Variable Height Panel End Caps

- Extruded plastic cap covers exposed panel end when in-line panels are of different heights.
- Specify trim color.

To order (Example): CI-ECPL-4254-SA  
 "In-Line Variable Height Panel End Cap, for use with 42-inch to 54-inch height panel transition, (12" height difference) sand trim."

Product	Use with Panel Heights	Width	Height	Depth
CI-ECPL-3242	32"/42"	2½"	Special 10"	1"
CI-ECPL-3248	32"/48"	2½"	Special 16"	1"
CI-ECPL-3254	32"/54"	2½"	Special 22"	1"
CI-ECPL-3262	32"/62"	2½"	Special 30"	1"
CI-ECPL-3266	32"/66"	2½"	Special 34"	1"
CI-ECPL-3272	32"/72"	2½"	Special 40"	1"
CI-ECPL-3280	32"/80"	2½"	Special 48"	1"
CI-ECPL-4248	42"/48"	2½"	6"	1"
CI-ECPL-4254	42"/54"	2½"	12"	1"
CI-ECPL-4262	42"/62"	2½"	20"	1"
CI-ECPL-4266	42"/66"	2½"	24"	1"
CI-ECPL-4272	42"/72"	2½"	30"	1"
CI-ECPL-4280	42"/80"	2½"	38"	1"
CI-ECPL-4854	48"/54"	2½"	6"	1"
CI-ECPL-4862	48"/62"	2½"	14"	1"
CI-ECPL-4866	48"/66"	2½"	18"	1"
CI-ECPL-4872	48"/72"	2½"	24"	1"
CI-ECPL-4880	48"/80"	2½"	32"	1"
CI-ECPL-5462	54"/62"	2½"	8"	1"
CI-ECPL-5466	54"/66"	2½"	12"	1"
CI-ECPL-5472	54"/72"	2½"	18"	1"
CI-ECPL-5480	54"/80"	2½"	26"	1"
CI-ECPL-6266	62"/66"	2½"	4"	1"
CI-ECPL-6272	62"/72"	2½"	10"	1"
CI-ECPL-6280	62"/80"	2½"	18"	1"
CI-ECPL-6672	66"/72"	2½"	6"	1"
CI-ECPL-6680	66"/80"	2½"	14"	1"
CI-ECPL-7280	72"/80"	2½"	8"	1"

# Panel Trim

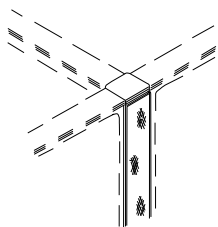

## T-Post (CTC) - Upholstered

- Fabric covered extruded plastic trim piece covers exposed panel ends where three panels form a "T" configuration.
- T-post top cap included.
- Specify trim color.
- Specify fabric color.

To order (Example): CI-CTC-42-BL-(XXX)  
"T-Post - Upholstered, 42-inch height, black trim, (fabric color)."

Product	Width	Height
CI-CTC-32	2½"	32"
CI-CTC-42	2½"	42"
CI-CTC-48	2½"	48"
CI-CTC-54	2½"	54"

Product	Width	Height
CI-CTC-62	2½"	62"
CI-CTC-66	2½"	66"
CI-CTC-72	2½"	72"
CI-CTC-80	2½"	80"

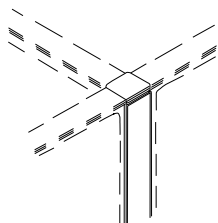

## T-Post (CTC) - Unupholstered

- Extruded plastic trim piece covers exposed panel ends where three panels form a "T" configuration.
- T-post top cap included.
- Specify trim color.

To order (Example): CI-CTUC-32-WG  
"T-Post - Unupholstered, 32-inch height, warm grey trim."

Product	Width	Height
CI-CTUC-32	2½"	32"
CI-CTUC-42	2½"	42"
CI-CTUC-48	2½"	48"
CI-CTUC-54	2½"	54"

Product	Width	Height
CI-CTUC-62	2½"	62"
CI-CTUC-66	2½"	66"
CI-CTUC-72	2½"	72"
CI-CTUC-80	2½"	80"

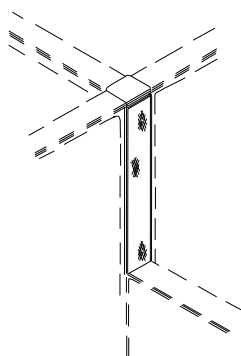

## Variable Height T-Posts (CTC) - Upholstered

- Fabric covered extruded plastic trim covers the exposed panel end when panels of different heights meet in "T" or 4-way configurations.
- T-post top cap included.
- Specify trim color.
- Specify fabric color.

To order (Example): CI-FECPT-4254-BL-(XXX)  
"Fabric-covered Variable Height T-Post, for use with 42-inch and 54-inch height panels, or with 54-inch and 66-inch height panels, (12-inch height difference), black trim, (fabric color)."

Product	Use with Panel Heights	Width	Height
CI-FECPT-3242	32"/42"	2½"	Special 10"
CI-FECPT-3248	32"/48"	2½"	Special 16"
CI-FECPT-3254	32"/54"	2½"	Special 22"
CI-FECPT-3262	32"/62"	2½"	Special 30"
CI-FECPT-3266	32"/66"	2½"	Special 34"
CI-FECPT-3272	32"/72"	2½"	Special 40"
CI-FECPT-3280	32"/80"	2½"	Special 48"
CI-FECPT-4248	42"/48"	2½"	6"
CI-FECPT-4254	42"/54"	2½"	12"
CI-FECPT-4262	42"/62"	2½"	20"
CI-FECPT-4266	42"/66"	2½"	24"
CI-FECPT-4272	42"/72"	2½"	30"
CI-FECPT-4280	42"/80"	2½"	38"
CI-FECPT-4854	48"/54"	2½"	6"
CI-FECPT-4862	48"/62"	2½"	14"
CI-FECPT-4866	48"/66"	2½"	18"
CI-FECPT-4872	48"/72"	2½"	24"
CI-FECPT-4880	48"/80"	2½"	32"
CI-FECPT-5462	54"/62"	2½"	8"
CI-FECPT-5466	54"/66"	2½"	12"
CI-FECPT-5472	54"/72"	2½"	18"
CI-FECPT-5480	54"/80"	2½"	26"
CI-FECPT-6266	62"/66"	2½"	4"
CI-FECPT-6272	62"/72"	2½"	10"
CI-FECPT-6280	62"/80"	2½"	18"
CI-FECPT-6672	66"/72"	2½"	6"
CI-FECPT-6680	66"/80"	2½"	14"
CI-FECPT-7280	72"/80"	2½"	8"

# Panel Trim

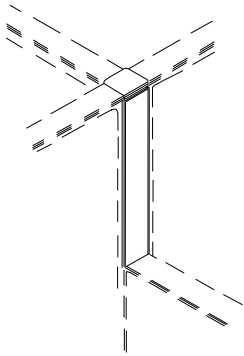

## Variable Height T-Posts (CTC) - Unupholstered

- Extruded plastic trim covers the exposed panel end when panels of different heights meet in "T" or 4-way configurations.
- T-post top cap included.
- Specify trim color.

To order (Example): CI-UECPT-3266-WG  
 "Variable Height T-Post Unupholstered, for use with 32-inch and 66-inch height panels, special 34-inch height, warm grey trim."

Product	Use with Panel Heights	Width	Height
CI-UECPT-3242	32"/42"	2½"	Special 10"
CI-UECPT-3248	32"/48"	2½"	Special 16"
CI-UECPT-3254	32"/54"	2½"	Special 22"
CI-UECPT-3262	32"/62"	2½"	Special 30"
CI-UECPT-3266	32"/66"	2½"	Special 34"
CI-UECPT-3272	32"/72"	2½"	Special 40"
CI-UECPT-3280	32"/80"	2½"	Special 48"
CI-UECPT-4248	42"/48"	2½"	6"
CI-UECPT-4254	42"/54"	2½"	12"
CI-UECPT-4262	42"/62"	2½"	20"
CI-UECPT-4266	42"/66"	2½"	24"
CI-UECPT-4272	42"/72"	2½"	30"
CI-UECPT-4280	42"/80"	2½"	38"
CI-UECPT-4854	48"/54"	2½"	6"
CI-UECPT-4862	48"/62"	2½"	14"
CI-UECPT-4866	48"/66"	2½"	18"
CI-UECPT-4872	48"/72"	2½"	24"
CI-UECPT-4880	48"/80"	2½"	32"
CI-UECPT-5462	54"/62"	2½"	8"
CI-UECPT-5466	54"/66"	2½"	12"
CI-UECPT-5472	54"/72"	2½"	18"
CI-UECPT-5480	54"/80"	2½"	26"
CI-UECPT-6266	62"/66"	2½"	4"
CI-UECPT-6272	62"/72"	2½"	10"
CI-UECPT-6280	62"/80"	2½"	18"
CI-UECPT-6672	66"/72"	2½"	6"
CI-UECPT-6680	66"/80"	2½"	14"
CI-UECPT-7280	72"/80"	2½"	8"

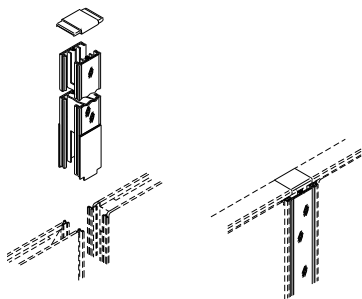

## 2-1/2" CTC Spacer

- Fabric covered plastic and aluminum extrusion that is used to provide a 2½" space along a run of panels.
- The CTC Spacer is used to make up the 2½" difference that is created in a workstation when a CTC intersection has taken place on the opposite wall.
- Two-way top cap included.
- Specify trim color.

- Available in 32" - 80" lengths.
- Specify fabric color.

To order (Example): CI-CTCS-80-BL-(XXX)  
 "Fabric Upholstered 2½-inch CTC Spacer, 80-inch length, black trim, (fabric color)."

Product	Width	Height
CI-CTCS-32	2½"	32"
CI-CTCS-42	2½"	42"
CI-CTCS-48	2½"	48"
CI-CTCS-54	2½"	54"
CI-CTCS-62	2½"	62"
CI-CTCS-66	2½"	66"
CI-CTCS-72	2½"	72"
CI-CTCS-80	2½"	80"



# Panel Trim

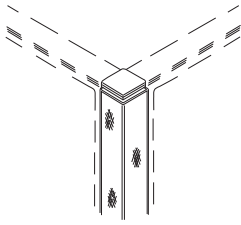

## 90° Corner Post (CAC) – Upholstered

- Fabric covered extruded plastic corner covers exposed panel ends where two panels form a 90° configuration.
- 90° corner top cap included.
- Specify trim color.

To order (Example): CI-CAC-42-SA-(XXX)  
 "Corner Post, 42-inch height, sand trim, (fabric color number)."

Product	Height	Width	Depth
CI-CAC-32	32"	2½"	2½"
CI-CAC-42	42"	2½"	2½"
CI-CAC-48	48"	2½"	2½"
CI-CAC-54	54"	2½"	2½"
CI-CAC-62	62"	2½"	2½"
CI-CAC-66	66"	2½"	2½"
CI-CAC-72	72"	2½"	2½"
CI-CAC-80	80"	2½"	2½"

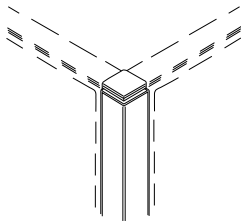

## 90° Corner Post (CAC) – Unupholstered

- Extruded plastic corner covers exposed panel ends where two panels form a 90° configuration.
- 90° corner top cap included.
- Specify trim color.

To order (Example): CI-CAUC-54-WG  
 "Corner Post, Unupholstered, 54-inch height, warm grey trim."

Product	Height	Width	Depth
CI-CAUC-32	32"	2½"	2½"
CI-CAUC-42	42"	2½"	2½"
CI-CAUC-48	48"	2½"	2½"
CI-CAUC-54	54"	2½"	2½"
CI-CAUC-62	62"	2½"	2½"
CI-CAUC-66	66"	2½"	2½"
CI-CAUC-72	72"	2½"	2½"
CI-CAUC-80	80"	2½"	2½"

# Panel Trim

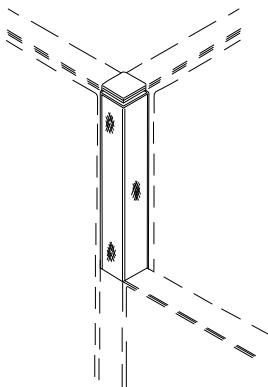

## Variable Height 90° Corner Post (CAC) – Upholstered

- Fabric covered extruded plastic corner covers exposed panel end where three panels of different heights meet in "T" configurations.
- 90° corner top cap included.
- Specify trim color.
- Specify fabric color.

To order (Example): CI-FECP-4254-SA-(XXX)  
 "Fabric Covered Variable Height Corner Post, for use with 42-inch and 54-inch height panels, (12-inch height, difference) sand trim, (fabric color)."

Product	Use with Panel Heights	Width	Height
CI-FECP-3242	32"/42"	2½"	Special 10"
CI-FECP-3248	32"/48"	2½"	Special 16"
CI-FECP-3254	32"/54"	2½"	Special 22"
CI-FECP-3262	32"/62"	2½"	Special 30"
CI-FECP-3266	32"/66"	2½"	Special 34"
CI-FECP-3272	32"/72"	2½"	Special 40"
CI-FECP-3280	32"/80"	2½"	Special 48"
CI-FECP-4248	42"/48"	2½"	6"
CI-FECP-4254	42"/54"	2½"	12"
CI-FECP-4262	42"/62"	2½"	20"
CI-FECP-4266	42"/66"	2½"	24"
CI-FECP-4272	42"/72"	2½"	30"
CI-FECP-4280	42"/80"	2½"	38"
CI-FECP-4854	48"/54"	2½"	6"
CI-FECP-4862	48"/62"	2½"	14"
CI-FECP-4866	48"/66"	2½"	18"
CI-FECP-4872	48"/72"	2½"	24"
CI-FECP-4880	48"/80"	2½"	32"
CI-FECP-5462	54"/62"	2½"	8"
CI-FECP-5466	54"/66"	2½"	12"
CI-FECP-5472	54"/72"	2½"	18"
CI-FECP-5480	54"/80"	2½"	26"
CI-FECP-6266	62"/66"	2½"	4"
CI-FECP-6272	62"/72"	2½"	10"
CI-FECP-6280	62"/80"	2½"	18"
CI-FECP-6672	66"/72"	2½"	6"
CI-FECP-6680	66"/80"	2½"	14"
CI-FECP-7280	72"/80"	2½"	8"

# Panel Trim

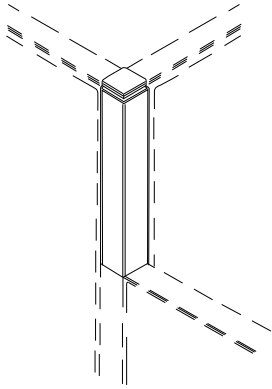

## Variable Height 90° Corner Post (CAC) – Unupholstered

- Extruded plastic corner covers exposed panel end where three panels of different heights meet in "T" configurations.
- 90° corner top cap included.
- Specify trim color.

To order (Example): CI-UECPC-5480-SA  
 "Variable Height Corner Post – Unupholstered, for use with 54-inch and 80-inch height panels, (26-inch height, difference) sand trim."

Product	Use with Panel Heights	Width	Height
CI-UECPC-3242	32"/42"	2½"	Special 10"
CI-UECPC-3248	32"/48"	2½"	Special 16"
CI-UECPC-3254	32"/54"	2½"	Special 22"
CI-UECPC-3262	32"/62"	2½"	Special 30"
CI-UECPC-3266	32"/66"	2½"	Special 34"
CI-UECPC-3272	32"/72"	2½"	Special 40"
CI-UECPC-3280	32"/80"	2½"	Special 48"
CI-UECPC-4248	42"/48"	2½"	6"
CI-UECPC-4254	42"/54"	2½"	12"
CI-UECPC-4262	42"/62"	2½"	20"
CI-UECPC-4266	42"/66"	2½"	24"
CI-UECPC-4272	42"/72"	2½"	30"
CI-UECPC-4280	42"/80"	2½"	38"
CI-UECPC-4854	48"/54"	2½"	6"
CI-UECPC-4862	48"/62"	2½"	14"
CI-UECPC-4866	48"/66"	2½"	18"
CI-UECPC-4872	48"/72"	2½"	24"
CI-UECPC-4880	48"/80"	2½"	32"
CI-UECPC-5462	54"/62"	2½"	8"
CI-UECPC-5466	54"/66"	2½"	12"
CI-UECPC-5472	54"/72"	2½"	18"
CI-UECPC-5480	54"/80"	2½"	26"
CI-UECPC-6266	62"/66"	2½"	4"
CI-UECPC-6272	62"/72"	2½"	10"
CI-UECPC-6280	62"/80"	2½"	18"
CI-UECPC-6672	66"/72"	2½"	6"
CI-UECPC-6680	66"/80"	2½"	14"
CI-UECPC-7280	72"/80"	2½"	8"

# Panel Trim

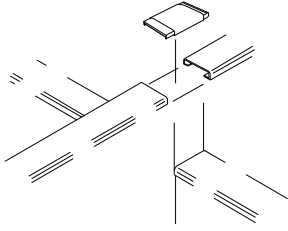

## Two Way Top Cap

- Provides continuation of the top cap design when used in conjunction with the CI-FECPT/CI-UECPT (in some configurations).
- Specify trim color.

To order (Example): CI-TWC-SA  
"Two Way Cap, sand trim."

Product	Width	Length
CI-TWC	2½"	2½"

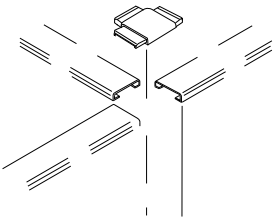

## Three Way Top Cap

- Provides continuation of the top cap when three panels the same height meet at a three way configuration.
- Specify trim color.

To order (Example): 53-2767-SA  
"Three Way Cap, sand trim."

Product	Width	Length
53-2767	2½"	2½"

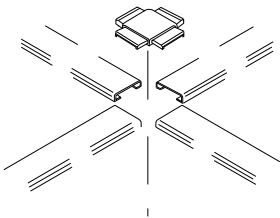

## Four Way Top Cap

- Provides continuation of the top cap when four panels the same height meet at 90° angles.
- Specify trim color.

To order (Example): CI-FWC-SA  
"Four Way Cap, sand trim."

Product	Width	Length
CI-FWC	2½"	2½"

# ERP Panel Trim

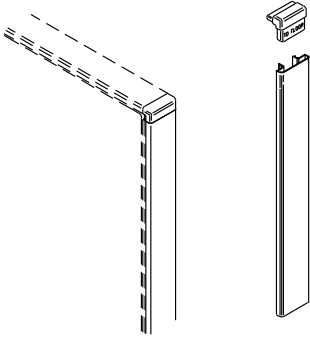

## ERP Panel End of Run Caps

- Extruded plastic cap covers panel end.
- Includes transition cap to top cap.
- Specify trim color.

To order (Example): CI-ERECP-52-GR  
 "ERP Panel End Cap, 52 inch height, blue grey trim.

Product	Width	Height	Depth
CI-ERECP-36	2½"	36"	1"
CI-ERECP-46	2½"	46"	1"
CI-ERECP-52	2½"	52"	1"
CI-ERECP-58	2½"	58"	1"

Product	Width	Height	Depth
CI-ERECP-66	2½"	66"	1"
CI-ERECP-70	2½"	70"	1"
CI-ERECP-76	2½"	76"	1"
CI-ERECP-84	2½"	84"	1"

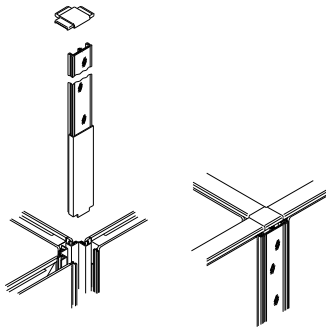

## ERP T-Post (CTC) - Upholstered

- Fabric covered extruded plastic trim piece covers exposed panel ends where three panels form a "T" configuration.
- T-post top cap included.
- Steel raceway cover included
- (2) 90° septum bridges included.

- Specify trim color.
- To order (Example): CI-ERCTC-70-BL-(XXX)  
 "ERP T-Post-Upholstered, 70 inch height, black trim fabric color #)."

Product	Width	Height	Depth
CI-ERCTC-36	2½"	36"	2½"
CI-ERCTC-46	2½"	46"	2½"
CI-ERCTC-52	2½"	52"	2½"
CI-ERCTC-58	2½"	58"	2½"

Product	Width	Height	Depth
CI-ERCTC-66	2½"	66"	2½"
CI-ERCTC-70	2½"	70"	2½"
CI-ERCTC-76	2½"	76"	2½"
CI-ERCTC-84	2½"	84"	2½"

# ERP Panel Trim

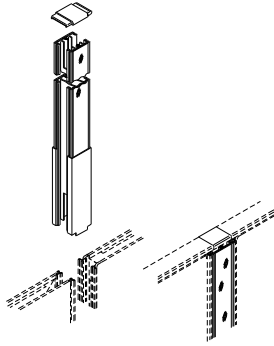

## ERP 2 1/2" CTC Spacer

- Fabric covered plastic and aluminum extrusion that is used to provide a 2 1/2" space along a run of panels.
- The CTC Spacer is used to make up the 2 1/2" difference that is created in a workstation when a CTC intersection has taken place on the opposite wall.
- Two way top cap included.
- Steel raceway cover included.

- Specify trim color.

To order (Example): CI-ERCTCS-76-BL-(XXX)  
 "Fabric Upholstered 2 1/2" CTC Spacer, 76 inch length, black trim, (fabric color #)."

Product	Width	Height
CI-ERCTCS-36	2 1/2"	36"
CI-ERCTCS-46	2 1/2"	46"
CI-ERCTCS-52	2 1/2"	52"
CI-ERCTCS-58	2 1/2"	58"

Product	Width	Height
CI-ERCTCS-66	2 1/2"	66"
CI-ERCTCS-70	2 1/2"	70"
CI-ERCTCS-76	2 1/2"	76"
CI-ERCTCS-84	2 1/2"	84"

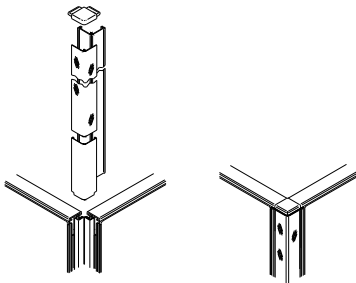

## ERP 90° Corner Post (CAC) - Upholstered

- Fabric covered extruded plastic corner covers exposed panel ends where two panels form a 90° configuration.
- 90° corner top cap included.
- Steel raceway cover included.

- 90° septum bridge included.
- Specify trim color.

To order (Example): CI-ERCAC-36-SA-(XXX)  
 "ERP Corner Post, 36 inch height, sand trim, (fabric color)."

Product	Width	Height	Depth
CI-ERCAC-36	2 1/2"	36"	2 1/2"
CI-ERCAC-46	2 1/2"	46"	2 1/2"
CI-ERCAC-52	2 1/2"	52"	2 1/2"
CI-ERCAC-58	2 1/2"	58"	2 1/2"

Product	Width	Height	Depth
CI-ERCAC-66	2 1/2"	66"	2 1/2"
CI-ERCAC-70	2 1/2"	70"	2 1/2"
CI-ERCAC-76	2 1/2"	76"	2 1/2"
CI-ERCAC-84	2 1/2"	84"	2 1/2"

# Panel Trim Accessories

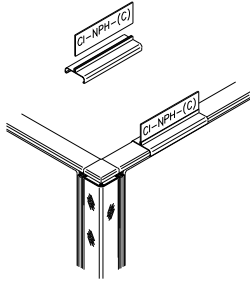

## Name Plate Holder

- PVC translucent name plate holder snaps onto the plastic top cap in any location.
- 8" long name plate holders will hold an engraved name plate up to .06 thick in a vertical position above the panel.
- Actual nameplate is supplied by the customer.

- Specify trim color.

To order: CI-NPH-BL, Name Plate Holder, Black.

Product	Length
CI-NPH	8

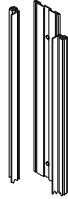

## Wall Mount

- Allows panels to be attached to existing walls.
- Includes mounting plate and hinges.
- Aluminum construction with painted finish.
- No hardware for wall attachment is included.
- For ERP panels, use the wall mount 4" shorter than the ERP panel height.

- Specify black (BL), blue grey (GR), sand (SA), light tone (LG), starlight silver (SX), cottonwood (CO) or warm grey (WG) trim color.

To order (Example): CI-CWM-42-GR  
"Wall Mount, 42-inch height, blue grey trim."

Product	Width	Height	Depth
CI-CWM-32	2½"	32"	¼"
CI-CWM-42	2½"	42"	¼"
CI-CWM-48	2½"	48"	¼"
CI-CWM-54	2½"	54"	¼"

Product	Width	Height	Depth
CI-CWM-62	2½"	62"	¼"
CI-CWM-66	2½"	66"	¼"
CI-CWM-72	2½"	72"	¼"
CI-CWM-80	2½"	80"	¼"

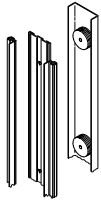

## Adjustable Wall Mount

- Allows panels to be attached to existing walls. Adjustable from 5/16" to 7/8".
- Includes mounting plate, hinges, adjustment pads, and wall plate.
- Aluminum construction with painted finish.
- For ERP panels, use the wall mount 4" shorter than the ERP panel height.

- No hardware for wall attachment is included.
- Specify trim color.

To order (Example): CI-CWMA-66-BL  
"Adjustable Wall Mount, 66-inch height, black trim."

Product	Width	Height	Maximum Depth
CI-CWMA-32	2½"	32"	1"
CI-CWMA-42	2½"	42"	1"
CI-CWMA-48	2½"	48"	1"
CI-CWMA-54	2½"	54"	1"

Product	Width	Height	Maximum Depth
CI-CWMA-62	2½"	62"	1"
CI-CWMA-66	2½"	66"	1"
CI-CWMA-72	2½"	72"	1"
CI-CWMA-80	2½"	80"	1"



## Panel Center Mount

- Provides for the attachment of an acoustical, glass, or open frame panel at a 90° angle along the face of another acoustical, glass, or open frame panel the same height to form a "T" configuration.
- For ERP panels, use the panel center mount 4" shorter than the ERP panel height.

- Panels must be the same height.
- Is not capable of passing power from panel-to-panel.

To order (Example): CI-PCM-32  
"Panel center mount for 32" height."

Product	Width	Height
CI-PCM-32	2½"	32"
CI-PCM-42	2½"	42"
CI-PCM-48	2½"	48"
CI-PCM-54	2½"	54"
CI-PCM-62	2½"	62"
CI-PCM-66	2½"	66"
CI-PCM-72	2½"	72"
CI-PCM-80	2½"	80"

# Stackable Panels

## Stackable Panel Section – Fabric

- Aluminum frame with fiberglass and fabric covered fiberboard faces.
- Alignment brackets allow a stackable section to slide onto an existing panel to increase the height.
- Stackable panel section may be installed without removing existing panel from the panel run.
- Product is UL 1286 listed.
- Stackable panel sections are connected through single piece poly hinges.
- Specify trim color.

To order (Example): SPSF36S18-BL-(XXX)  
 “Stackable Panel Section Fabric, 36-inch width, stackable 18-inch height, black trim, (fabric color).”

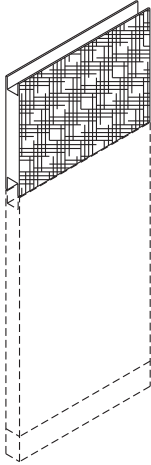

Product	Width	Height
SPSF24S12	24"	12"
SPSF24S14	24"	14"
SPSF24S18	24"	18"
SPSF24S24	24"	24"
SPSF24S30	24"	30"
SPSF30S12	30"	12"
SPSF30S14	30"	14"
SPSF30S18	30"	18"
SPSF30S24	30"	24"
SPSF30S30	30"	30"
SPSF36S12	36"	12"
SPSF36S14	36"	14"
SPSF36S18	36"	18"
SPSF36S24	36"	24"
SPSF36S30	36"	30"

Product	Width	Height
SPSF42S12	42"	12"
SPSF42S14	42"	14"
SPSF42S18	42"	18"
SPSF42S24	42"	24"
SPSF42S30	42"	30"
SPSF48S12	48"	12"
SPSF48S14	48"	14"
SPSF48S18	48"	18"
SPSF48S24	48"	24"
SPSF48S30	48"	30"



# Stackable Panels

## Stackable Panel Section – Glass Frame

- Constructed of a painted aluminum frame with 1/4" clear or bronze tempered glass.
- Alignment brackets allow a stackable section to slide onto an existing panel to increase the height.
- Stackable panel section may be installed without removing existing panel from the panel run.
- Product is UL 1286 listed.
- Stackable panel sections are connected through single piece poly hinges.

- Specify trim color.

To order (Example): SPSPG24S30-GR  
 "Stackable Panel Section Glass, 24-inch width, stackable 30-inch height, blue grey trim."

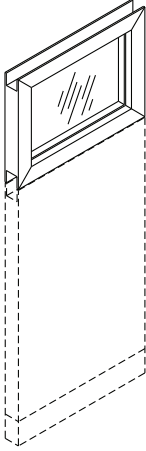

Product	Width	Height
SPSPG24S12	24"	12"
SPSPG24S14	24"	14"
SPSPG24S18	24"	18"
SPSPG24S24	24"	24"
SPSPG24S30	24"	30"
SPSPG30S12	30"	12"
SPSPG30S14	30"	14"
SPSPG30S18	30"	18"
SPSPG30S24	30"	24"
SPSPG30S30	30"	30"
SPSPG36S12	36"	12"
SPSPG36S14	36"	14"
SPSPG36S18	36"	18"
SPSPG36S24	36"	24"
SPSPG36S30	36"	30"

Product	Width	Height
SPSPG42S12	42"	12"
SPSPG42S14	42"	14"
SPSPG42S18	42"	18"
SPSPG42S24	42"	24"
SPSPG42S30	42"	30"
SPSPG48S12	48"	12"
SPSPG48S14	48"	14"
SPSPG48S18	48"	18"
SPSPG48S24	48"	24"
SPSPG48S30	48"	30"

# Stackable Panels

## Stackable Panel Section – Open Frame

- Constructed of a painted aluminum frame.
- Alignment brackets allow a stackable section to slide onto an existing panel to increase the height.
- Stackable panel section may be installed without removing existing panel from the panel run.
- Product is UL 1286 listed.
- Stackable panel sections are connected through single piece poly hinges.

- Specify trim color.

To order (Example): SPS036S18-WG  
 “Stackable Panel Section Open, 36-inch width, stackable 18-inch height, warm grey trim.”

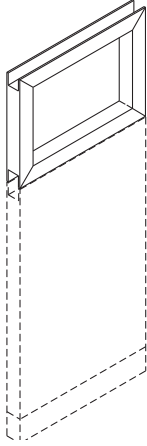

Product	Width	Height
SPS024S12	24"	12"
SPS024S14	24"	14"
SPS024S18	24"	18"
SPS024S24	24"	24"
SPS024S30	24"	30"
SPS030S12	30"	12"
SPS030S14	30"	14"
SPS030S18	30"	18"
SPS030S24	30"	24"
SPS030S30	30"	30"
SPS036S12	36"	12"
SPS036S14	36"	14"
SPS036S18	36"	18"
SPS036S24	36"	24"
SPS036S30	36"	30"

Product	Width	Height
SPS042S12	42"	12"
SPS042S14	42"	14"
SPS042S18	42"	18"
SPS042S24	42"	24"
SPS042S30	42"	30"
SPS048S12	48"	12"
SPS048S14	48"	14"
SPS048S18	48"	18"
SPS048S24	48"	24"
SPS048S30	48"	30"

# Stackable Panel Trim

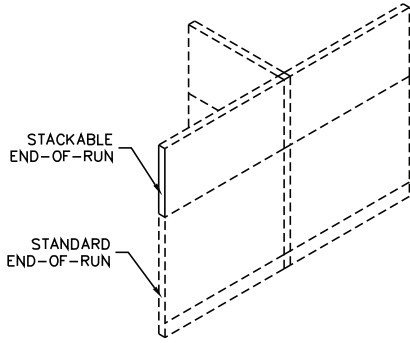

## Stackable End of Run

- Extruded plastic cap covers stackable section end.
- Specify to match the height of the stackable section.
- Includes a sleeve to align with existing end of run trim.
- Specify trim color.

To order (Example): SPSEORS24-BL  
 "Stackable Panel Section End of Run, stackable 24-inch height, black trim."

Product	Use on Stackable Panels:	Product	Use on Stackable Panels:
SPSEORS12	S12	SPSEORS24	S24
SPSEORS14	S14	SPSEORS30	S30
SPSEORS18	S18		

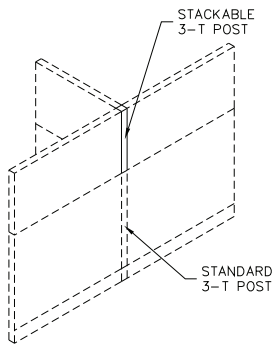

## Stackable 3 T-Post (CTC)

- Fabric covered extruded plastic trim piece covers exposed stackable section ends where three sections from a "T" configuration.
- Specify to match the height of the stackable sections.
- Specify trim color.

- Specify fabric color.

To order (Example): SPSCTFCS18-GR-(XXX)  
 "Stackable Panel Section 3-T Post (CTC), stackable 18-inch height, blue grey trim, (fabric color)."

Product	Use on Stackable Panels:	Product	Use on Stackable Panels:
SPSCTFCS12	S12	SPSCTFCS24	S24
SPSCTFCS14	S14	SPSCTFCS30	S30
SPSCTFCS18	S18		

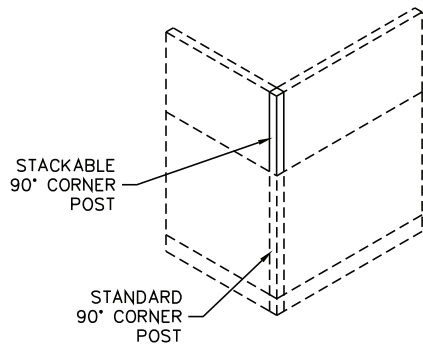

## Stackable 90° Corners (CAC)

- Fabric covered extruded plastic corner covers exposed stackable section ends where two sections from a 90° configuration.
- Specify to match the height of the stackable sections.
- Specify trim color.

- Specify fabric color.

To order (Example): SPSCAFCS12-WG-(XXX)  
 "Stackable Panel Section 90° Corner (CAC), stackable 12-inch height, warm grey trim, (fabric color)."

Product	Use on Stackable Panels:	Product	Use on Stackable Panels:
SPSCAFCS12	S12	SPSCAFCS24	S24
SPSCAFCS14	S14	SPSCAFCS30	S30
SPSCAFCS18	S18		

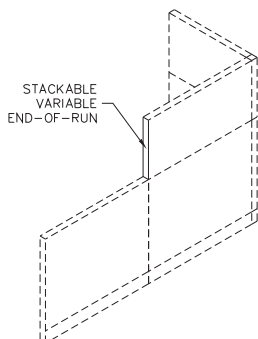

## Stackable Variable End of Run

- Extruded plastic cap covers a stackable section end, when the adjacent panel steps down in height (see drawing).
- Specify to match the height of the stackable sections, or the difference in panel heights.
- Specify trim color.

To order (Example): SPSVEORS30-SA  
 "Stackable Panel Variable End of Run, stackable 30-inch height, sand trim."

Product	Use when diff. in height equals:	Product	Use when diff. in height equals:
SPSVEORS06	6"	SPSVEORS18	18"
SPSVEORS12	12"	SPSVEORS24	24"
SPSVEORS14	14"	SPSVEORS30	30"

# Stackable Panel Trim

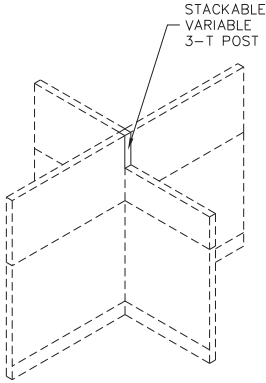

## Stackable Variable 3-T Post (CTC)

- Fabric covered extruded plastic trim piece covers exposed stackable section ends where three sections form a "T" configuration, and a fourth shorter panel is at a lower height (see drawing).
- Specify to match the height of the stackable section, or the difference in panel heights.
- Specify fabric color.

- Specify trim color.

To order (Example): SPSVCTFCS06-BL-(XXX)  
 "Stackable Panel Section Variable 3-T Post (CTC), stackable 6-inch height, black trim, (fabric color)."

Product	Use when diff. in height equals:
SPSVCTFCS06	6"
SPSVCTFCS12	12"
SPSVCTFCS14	14"

Product	Use when diff. in height equals:
SPSVCTFCS18	18"
SPSVCTFCS24	24"
SPSVCTFCS30	30"

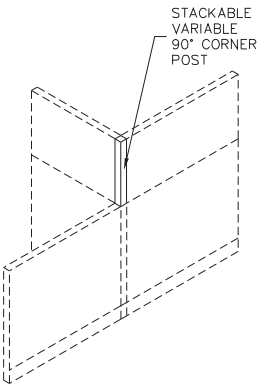

## Stackable Variable 90° Corners (CAC)

- Fabric covered extruded plastic corner covers exposed stackable section ends where two stackable sections from a 90° configuration, and a 3rd (or 3rd and 4th) panel(s) is at a lower height (see drawing).
- Specify to match the height of the stackable sections, or the difference in panel heights.
- Specify fabric color.

- Specify trim color.

To order (Example): SPSVCAFCS24-WG-(XXX)  
 "Stackable Panel Section Variable 90° Corner (CAC), stackable 24-inch height, warm grey, (fabric color)."

Product	Use when diff. in height equals:
SPSVCAFCS06	6"
SPSVCAFCS12	12"
SPSVCAFCS14	14"

Product	Use when diff. in height equals:
SPSVCAFCS18	18"
SPSVCAFCS24	24"
SPSVCAFCS30	30"

# Panel Doors

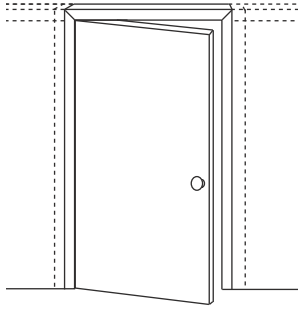

## Door

- Provides visual and acoustical privacy.
- For use in conjunction with 80" panels only.
- The 42" door actually gives you an opening 34 3/4" wide when the door is opened.
- Laminate surface, or laminate/veneer surface on door.
- Locking and non-locking options.

- Specify trim color.
- Specify laminate or veneer color.
- See Specifications Section for applications.

To order (Example): CI-DRR42L-BL-XX  
 "Door, right-hand open, 42-inch width, locking, black trim, (laminate color)."

Product	Width	Height	Opening	Hand	Lock
CI-DRR42L	42"	80"	34 3/4"	Right	Locking
CI-DRR42N	42"	80"	34 3/4"	Right	Non-Locking
CI-DRL42L	42"	80"	34 3/4"	Left	Locking
CI-DRL42N	42"	80"	34 3/4"	Left	Non-Locking

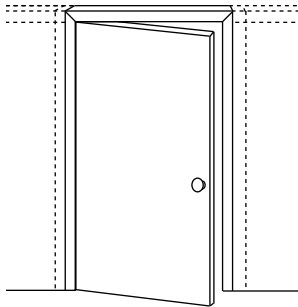

## ERP Door

- Provides visual and acoustical privacy.
- 4" taller than standard doors.
- To be used with 84" ERP panels only.
- The 42" door actually gives you an opening 34 3/4" wide when the door is opened.
- Laminate surface, or laminate/veneer surface on door.
- Locking and non-locking options.

- Specify trim color.
- Specify laminate or veneer color.
- See Specifications Section for applications.

To order (Example): CI-EDRR42L-BL-XX  
 "Door, right-hand open, 42-inch width, locking, black trim, (laminate color)."

Product	Width	Height	Opening	Hand	Lock
CI-EDRR42L	42"	84"	34 3/4"	Right	Locking
CI-EDRR42N	42"	84"	34 3/4"	Right	Non-Locking
CI-EDRL42L	42"	84"	34 3/4"	Left	Locking
CI-EDRL42N	42"	84"	34 3/4"	Left	Non-Locking

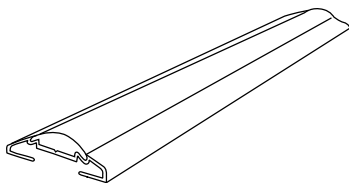

## Door Threshold

- Extruded aluminum door threshold with rubber seal strip.
- Attaches to bottom of door frame.
- Specify trim color.
- See installation instructions.

- Use with 42" door units.

To order (Example): CI-DRTH-42-BL  
 "Door Threshold, 42-inch width, black."

## Product

CI-DRTH-42

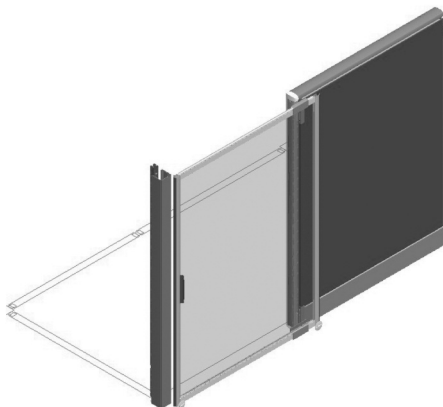

## Rolling Screen Door

- Provides non-locking visual security.
- Aluminum frame with clear or frosted (opal) fluted plastic core.
- Acrylic wheels allow ease of travel across flooring.
- Door mounts to a 66" or higher panel and spans across a 42" opening.
- Available in 48" width and 66" height.
- Frame and mounting brackets are powder-coated to match panel trim color.

- Specify trim color.

To order (Example): RSD4266FHC-OP-3K-WG  
 "Rolling Screen Door, 42" wide, 66" high, opal plastic, System XXI, warm grey."

Product	Width	Height
RSD4266FHC/CP/3K/XX	42"	66"
RSD4266FHC/OP/3K/XX	42"	66"

# Electrical

**Universal 10-Wire electrical product is available in two styles, 442 and 622. The two styles will not connect together.**

## 10-Wire Power Distribution System

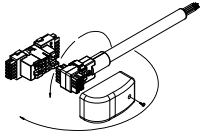

### Universal Base Feed

- Provides power from fixed floor or wall sources to panel power distribution system.
- Product is UL 1286 listed.
- Has a standard 72" long "liquid-tight" flexible conduit that pivots 180° left to right. 12', 18' and 24' also available.
- Available in 442 or 622 style.

- Specify trim color.

To order (Example): CI-T4BF-GR  
"Universal Base Feed Wire 442, blue grey trim."

442 Product	Length	Style
CI-T4BF	72"	442

622 Product	Length	Style
CI-T6BF	72"	622

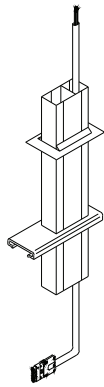

### Universal Top Feed

- Provides power from ceiling source to panel power distribution system.
- Product is UL 1286 listed.
- Includes 7" aluminum power pole, top cap section, ceiling sleeve, and 144" power feed cable.
- Specify trim color.

To order (Example): CI-T6TF-BL  
"Universal Top Feed 622, black trim."

- Available in 442 or 622 style.

442 Product	Conduit Length	Power Pole Length
CI-T4TF	144"	84"

622 Product	Conduit Length	Power Pole Length
CI-T6TF	144"	84"



### Universal Panel-To-Panel Jumper

- Used to connect one powered panel to an adjacent powered panel.
- Product is UL 1286 listed.
- Available in two lengths.
- Available in 442 or 622 style.

- 17" is used on inline and 90 degree corners.
- 20" is used on straight intersection conditions.

To order (Example): CI-T4PJ-18  
"Universal Panel-to-Panel Jumper 442 style."

442 Product	Length
CI-T4PJ-17	17"
CI-T4PJ-20	20"

622 Product	Length
CI-T6PJ-17	17"
CI-T6PJ-20	20"

# Electrical

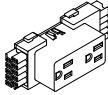

## Universal Duplex Receptacles

- Attaches to wireways of 10 wire powered panels.
- Provides two (duplex) receptacles each rated at 15 amps.
- Available in 442 and 622 style.
- Product is UL1286 listed.
- Specify trim color.

- Some circuits are isolated ground circuits (442 - 3 & 4) (622 - 4, 5, & 6). Isolated ground receptacles are color coded orange. (See pages 64/65 for schematic details).

To order (Example): CI-T6CER-4  
 "Universal 622 duplex receptacle, circuit #4,  
 (no color required)."

### 442 Product      Circuit#

CI-T4CER-1-color	1
CI-T4CER-2-color	2
CI-T4CER-3	3I
CI-T4CER-4	4I

I Isolated ground circuit

### 622 Product      Circuit#

CI-T6CER-1-color	1
CI-T6CER-2-color	2
CI-T6CER-3-color	3
CI-T6CER-4	4I
CI-T6CER-5	5I
CI-T6CER-6	6I

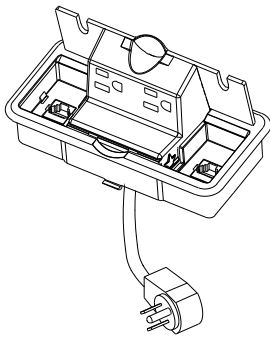

## PowerUp® Surface Mounted Power and Data

- Unit mounts into a 3" x 6¼" cutout in a worksurface.
- Unit provides a flip up duplex receptacle and two locations that will accept Lucent Technologies modular data jacks.
- Unit is fully UL listed for use as a Temporary Power Tap.
- Cord comes in three lengths, 22", 42" and 108".
- Slots in cover allow flip up cover to be closed when data devices are hooked up.
- Product is UL1286 listed.

- Specify trim color.
- **Data jacks must be ordered separately by customer.**
- PowerUp can be used with 10 wire panel electrical systems or plugged into the building receptacles.

To order (Example): 13-2260U-42-BL  
 "PowerUp unit, slotted cover, 42" long cord, Black."

### Product      Cord Length

13-2260U-22	22"
13-2260U-42	42"
13-2260U-108	108"

# Electrical

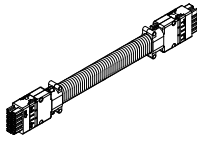

## Universal Power Pass Through

- Provides continuation of power through a non-powered panel that is between two powered panels.
- Receptacle access is not provided on power pass through panels.
- Panel-to-panel connectors are not required.

- Product is UL 1286 listed.

To order (Example): CI-T4EPT-18  
"Power Pass Through, for 18-inch wide panel."

442 Product	Corresponding Panel Width
CI-T4EPT-12	12"
CI-T4EPT-18	18"
CI-T4EPT-24	24"
CI-T4EPT-30	30"
CI-T4EPT-36	36"
CI-T4EPT-42	42"
CI-T4EPT-48	48"
CI-T4EPT-54	54"
CI-T4EPT-60	60"

622 Product	Corresponding Panel Width
CI-T6EPT-12	12"
CI-T6EPT-18	18"
CI-T6EPT-24	24"
CI-T6EPT-30	30"
CI-T6EPT-36	36"
CI-T6EPT-42	42"
CI-T6EPT-48	48"
CI-T6EPT-54	54"
CI-T6EPT-60	60"

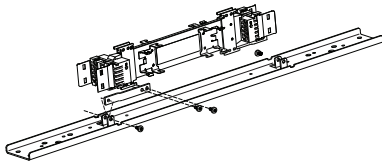

## Pan Retrofit Kits — 8 Wire-10 Wire Universal

- Consists of a 10-wire rigid wireway, two mounting bars, two powered raceway covers with bezels, fillers and attachment screws.
- Provides for the conversion of a powered or non-powered 8-wire pan to accept a 10-wire rigid wireway (24"-60" panels only).
- **Panel jumpers and receptacles must be ordered separately.**
- Product is UL 1286 listed.

- Specify trim color.

To order (Example): 6ERP-24-SA  
"Pan Retrofit Kit - 8-Wire to 10-Wire Universal, 24" panel, sand trim."

T6/622	T4/442	Panel Length
6EPR-24	4EPR-24	24"
6EPR-30	4EPR-30	30"
6EPR-36	4EPR-36	36"
6EPR-42	4EPR-42	42"
6EPR-48	4EPR-48	48"
6EPR-54	4EPR-54	54"
6EPR-60	4EPR-60	60"

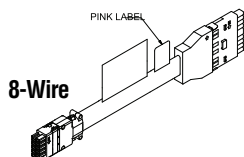
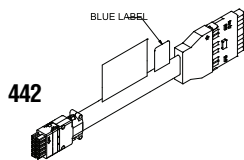
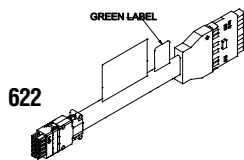

## 10-Wire Converter to Universal 622 Wiring

- Designed for adjacent panel connections between rigid wireways
- Converts power from System XXI 622 10-wireways to Universal 622 wireways
- Power is UL 1286 listed

## 10-Wire Converter to Universal 442 Wiring

- Designed for adjacent panel connections between rigid wireways
- Converts power from System XXI 442 10-wireways to Universal 442 wireways
- Power is UL 1286 listed

## 8-Wire Converter to Universal 622-(422) Wiring

- Designed for adjacent panel connections between rigid wireways
- Converts power from System XXI 422 10-wireways to Universal 622 wireways
- Power is UL 1286 listed
- Must be used with 8-wire and 622 conversions

To order (Example): UET10CONV422.20  
"Converts 8-wire when using 10-wire 622 at inline or 90 degree conditions."  
• Only available in 20" length

Product	Length	Length
UET10CONV622	17	20
UET10CONV442	17	20
UET10CONV422	n/a	20



# Worksurfaces - T-edge

## Rectangular Worksurfaces T-edge

- Rectangular surfaces consist of 1-1/8" particle board between laminate and backer with polypropylene (PP) T-edge molding around the perimeter of the surfaces.
- Meets BIFMA standards: X5.6-1993.
- 60" worksurfaces include reinforcing bars set into the underside of the worksurface.
- Includes worksurface cantilever brackets.
- All Surfaces 66" and longer are provided with an additional left hand cantilever bracket for mid-surface support.

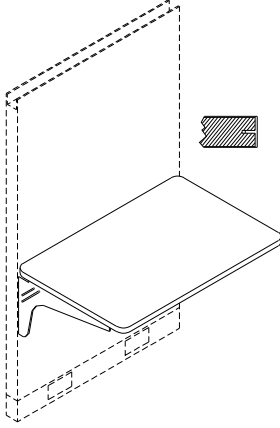

- Cantilevers allow mounting to panels at 1" height increments.
- Worksurfaces are predrilled for suspended pedestals.
- Specify trim color.
- Specify laminate color.
- 3" round grommet optional. Refer to page 53 to specify.

To order (Example): CI-WS-2024-GR-XXX  
 "Rectangular Worksurface, 20-inch depth, 24-inch width, blue grey trim, (laminate color number)."

Product	Depth	Width
CI-WS-2024	20"	24"
CI-WS-2030	20"	30"
CI-WS-2036	20"	36"
CI-WS-2042	20"	42"
CI-WS-2048	20"	48"
CI-WS-2054	20"	54"
CI-WS-2060	20"	60"
CI-WS-2066	20"	66"
CI-WS-2072	20"	72"
CI-WS-2418	24"	18"
CI-WS-2424	24"	24"
CI-WS-2430	24"	30"
CI-WS-2436	24"	36"
CI-WS-2442	24"	42"
CI-WS-2448	24"	48"
CI-WS-2454	24"	54"
CI-WS-2460	24"	60"

Product	Depth	Width
CI-WS-2466	24"	66"
CI-WS-2472	24"	72"
CI-WS-2478	24"	78"
CI-WS-2484	24"	84"
CI-WS-2490	24"	90"
CI-WS-2496	24"	96"
CI-WS-3024	30"	24"
CI-WS-3030	30"	30"
CI-WS-3036	30"	36"
CI-WS-3042	30"	42"
CI-WS-3048	30"	48"
CI-WS-3054	30"	54"
CI-WS-3060	30"	60"
CI-WS-3066	30"	66"
CI-WS-3072	30"	72"
CI-WS-3078	30"	78"
CI-WS-3084	30"	84"
CI-WS-3090	30"	90"
CI-WS-3096	30"	96"

## 90° Corner Worksurfaces T-edge

- Product is constructed of 1-1/8" particle board between laminate and backer with polypropylene (PP) T-edge molding around the perimeter of the surfaces.
- Meets BIFMA standards: X5.6-1993.
- 90° corner worksurfaces provide a straight front edge to access corner worksurface area.
- A 36" width attaches to 36" wide panels; 48" width to 48" wide panels.
- Mounting hardware is included. A left hand cantilever is provided for rear corner.

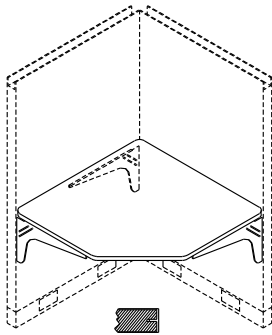

- Worksurfaces are predrilled for adjustable keyboard pad.
- Cantilevers allow mounting to panels at 1" height increments.
- Specify trim color.
- Specify laminate color.
- 3" round grommet optional. Refer to page 53 to specify.

To order (Example): CI-WS90-2436-BL-XXX  
 "90° Corner Worksurface, 24-inch depth, 36-inch width, 15-1/2-inch front, black trim, (laminate color number)."

Product	Depth	Panel Width	Front Edge
CI-WS90-2436	24"	36"	15½"
CI-WS90-2442	24"	42"	23¾"
CI-WS90-2448	24"	48"	32½"
CI-WS90-3042	30"	42"	15½"
CI-WS90-3048	30"	48"	23¾"

# Worksurfaces - T-edge

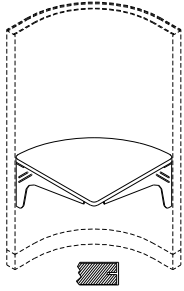

## Curved Worksurfaces T-edge

- Curved worksurfaces consist of 1-1/8" particle board between laminate and backer with vinyl T-edge molding around the perimeter of the surfaces.
- Meets BIFMA standards: X5.6-1993
- Worksurface is typically used so radius corresponds to curved panels.
- Sides match up to 24" deep worksurfaces.

- Includes worksurface cantilever brackets.
- Specify trim color.
- Specify laminate color.

To order (Example): CI-WSC-24-GR-XXX  
 "Curved Worksurface, blue grey trim, (laminate color number)."

Product	Depth	Width
CI-WSC-24	24"	24"

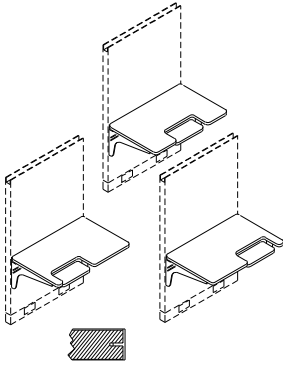

## Keyboard Worksurfaces T-edge

- Worksurfaces and pads consist of 1-1/8" particle board between laminate and backer with vinyl.
- Meets BIFMA standards: X5.6-1993.
- Keyboard worksurfaces contain a height adjustable pad in left, center or right locations.
- Pad is 24" wide and 10" deep.
- T-edge molding around the perimeter of the surfaces.
- Includes worksurface cantilever brackets.
- Cantilevers allow mounting to panels at 1" height increments.

- Keyboard allows 4" of height adjustment.
- Specify trim color.
- Specify laminate color.
- 3" round grommet optional. Refer to page 53 to specify.

To order (Example): CI-WSKL-3048-SA-XXX  
 "Keyboard Worksurface, Left (pad location), 30-inch depth, 48-inch width, sand trim, (laminate color number)."

Product	Depth	Width	Pad Location
CI-WSKL-3048	30"	48"	Left
CI-WSKC-3048	30"	48"	Center
CI-WSKR-3048	30"	48"	Right
CI-WSKL-3060	30"	60"	Left
CI-WSKC-3060	30"	60"	Center
CI-WSKR-3060	30"	60"	Right

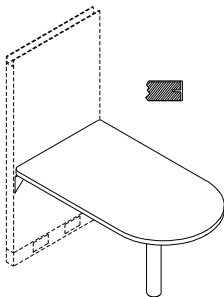

## D-Shaped Worksurfaces - Panel Mount T-edge

- D-shaped worksurfaces end-mount to panels.
- Surface consists of 1-1/8" particle board between laminate and backer with vinyl T-edge molding around the perimeter.
- Meets BIFMA standards: X5.6-1993.
- The round end is supported by a metal column, straight end supported by worksurface support brackets and lock clips.
- Includes mounting hardware.

- Glide provides height adjustability for the column.
- Specify trim color.
- Specify laminate color.
- 3" round grommet optional. Refer to page 53 to specify.

To order (Example): CI-WSD-3048-SA-XXX  
 "D-Shaped Worksurface, 30-inch depth, 48 inch length, sand trim (laminate color number)."

Product	Depth	Length
CI-WSD-2460	24"	60"
CI-WSD-2472	24"	72"
CI-WSD-3048	30"	48"
CI-WSD-3054	30"	54"
CI-WSD-3060	30"	60"
CI-WSD-3072	30"	72"
CI-WSD-3660	36"	60"
CI-WSD-3672	36"	72"

# Worksurfaces - T-edge

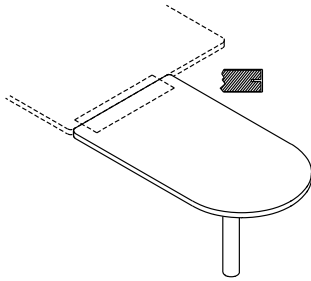

## D-Shaped Worksurfaces (End Mount) T-edge

- D-shaped worksurfaces end-mount to work surfaces at 29"-30" height.
- The round end is supported by a metal column, straight end supported by splice plate that attaches to adjacent worksurface.
- Surface consists of 1-1/8" particle board between laminate and backer with vinyl T-edge molding around the perimeter.
- Meets BIFMA standards: X5.6-1993.
- Includes mounting hardware.

- Glide provides height adjustability for the column.
- Specify trim color.
- Specify laminate color.

To order (Example): CI-WSDSM-3048-SA-XXX  
"End Mount D-Shaped Worksurface, 30" depth, 48" length, sand trim (laminate color number)."

Product	Depth	Length
CI-WSDSM-3048	30"	48"
CI-WSDSM-3060	30"	60"
CI-WSDSM-3072	30"	72"
CI-WSDSM-3660	36"	60"
CI-WSDSM-3672	36"	72"

## Adjustable D-Leg Worksurface (Panel Mount) T-edge

- Same as standard D-leg worksurfaces except the metal column that supports the round end is height adjustable.
- Adjustable height is specified as **DOWN** from the standard 29" height (24"-29") or **UP** from the standard 29" height (29"-34"). See Figure 1.

To order (Example): CI-WSDAU-2460-BL-XXX  
"Adjustable height D-Leg worksurface, panel mount, adjustable UP (AU = 29"-34"), 24" wide, 60" long, black trim, (laminate color number)."

Product	Adjustment Height
CI-WSDAD-2460	24" - 29"
CI-WSDAD-2472	24" - 29"
CI-WSDAD-3048	24" - 29"
CI-WSDAD-3054	24" - 29"
CI-WSDAD-3060	24" - 29"
CI-WSDAD-3072	24" - 29"
CI-WSDAD-3660	24" - 29"
CI-WSDAD-3672	24" - 29"

Product	Adjustment Height
CI-WSDAU-2460	29" - 34"
CI-WSDAU-2472	29" - 34"
CI-WSDAU-3048	29" - 34"
CI-WSDAU-3054	29" - 34"
CI-WSDAU-3060	29" - 34"
CI-WSDAU-3072	29" - 34"
CI-WSDAU-3660	29" - 34"
CI-WSDAU-3672	29" - 34"

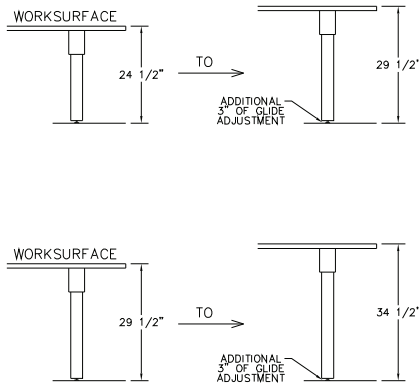

Figure 1

## Adjustable D-Leg Worksurface (End Mount) T-edge

- Same as standard D-leg worksurfaces except the metal column that supports the round end is height adjustable.
- Adjustable height is specified as **DOWN** from the standard 29" height (24"-29") or **UP** from the standard 29" height (29"-34"). See Figure 1.

To order (Example): CI-WSDSMAD-3060-SA-XXX  
"Adjustable height D-Leg worksurface, end mount, adjustable DOWN (AD = 24"-29"), 30" wide, 60" long, sand trim, (laminate color number)."

Product	Adjustment Height
CI-WSDSMAD-3048	24" - 29"
CI-WSDSMAD-3060	24" - 29"
CI-WSDSMAD-3072	24" - 29"
CI-WSDSMAD-3660	24" - 29"
CI-WSDSMAD-3672	24" - 29"

Product	Adjustment Height
CI-WSDSMAU-3048	29" - 34"
CI-WSDSMAU-3060	29" - 34"
CI-WSDSMAU-3072	29" - 34"
CI-WSDSMAU-3660	29" - 34"
CI-WSDSMAU-3672	29" - 34"

## Adjustable D-Leg

- Designed for use on any conference-end work surface, can be used in place of the metal column on any D shaped work surface. See Figure 1.
- Two adjustable height options available.
- Table is adjustable in 1" increments.
- Leg is field installable.

- Height adjustment glide included.
- Specify trim color.

To order (Example): CI-ADL-2429-SA  
"Adjustable D-Leg, 24" - 29", sand color."

Product	Size
CI-ADL-2429	24" - 29"
CI-ADL-2934	29" - 34"

# Worksurfaces - T-edge

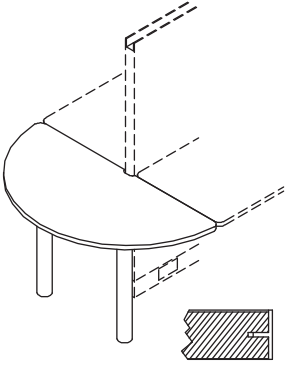

## Conference End Worksurface - T-edge

- Conference End worksurfaces consist of 1-1/8" particle board between laminate and backer with vinyl T-edge molding around the perimeter of the surface.
- Worksurface includes two 3" diameter metal legs with adjustable glides, and connecting hardware to attach it to the ends of the other worksurfaces.
- Specify trim color.
- Specify laminate color.
- Meets BIFMA standards: x5.6 - 1993

To order (Example): WCE3163-BN-XXX-BL  
 "Conference End Worksurface, 31-inch deep at middle of radius, 63-inch wide along flat edge, vinyl T-edging, (laminate color number), black trim."

Product	Depth at Middle of Radius	Width of Flat Edge	Connects Two Surfaces
WCE2551-BN	25"	51"	24"
WCE3151-BN	31"	51"	24"
WCE3163-BN	31"	63"	30"
WCE3763-BN	37"	63"	30"

# Worksurfaces - 2mm Polypropylene (PP)

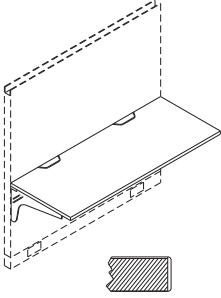

## Rectangular Worksurface - 2mm PP Edge

- Rectangular worksurfaces consist of 1-1/8" particle board between laminate and backer with 2mm PP edge banding around the perimeter of the surfaces.
- Meets BIFMA standards: X5.6-1993.
- 60" worksurfaces include reinforcing bars set into the underside of the worksurface.
- Includes worksurface supports.
- All surfaces 66" and longer are provided with an additional left-hand cantilever bracket for mid-surface support.
- Cantilever brackets allow mounting to panels at 1" height increments.

- Worksurfaces are predrilled for suspended pedestals.
- Worksurfaces up to 54" have one slimline grommet centered along the back edge. Over 54" have two slimline grommets.
- Specify trim color.
- Specify laminate color.

To order (Example): WR2454-3L-XXX-SA  
 "Rectangular worksurface, 24-inch deep, 54-inch long, 2mm PP edge, (laminate color), sand trim."

Product	Depth	Width	Product	Depth	Width
WR2418	24"	18"	WR3024	30"	24"
WR2424	24"	24"	WR3030	30"	30"
WR2430	24"	30"	WR3036	30"	36"
WR2436	24"	36"	WR3042	30"	42"
WR2442	24"	42"	WR3042	30"	48"
WR2448	24"	48"	WR3054	30"	54"
WR2454	24"	54"	WR3060	30"	60"
WR2460	24"	60"	WR3072	30"	72"
WR2472	24"	72"	WR3078	30"	78"
WR2478	24"	78"	WR3084	30"	84"
WR2484	24"	84"	WR3090	30"	90"
WR2490	24"	90"	WR3096	30"	96"
WR2496	24"	96"			

# Worksurfaces - 2mm Polypropylene (PP)

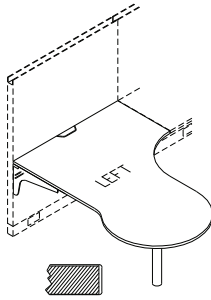

## “P” Shaped Peninsula Worksurfaces - 2mm PP Edge

- “P” Shaped Peninsula worksurfaces consist of 1-1/8” particle board between laminate and backer with 2mm PP edge banding around the perimeter of the surfaces.
- Includes worksurface supports.
- Cantilever brackets allow mounting to panels at 1” height increments.
- Specify Left-hand or Right-hand (see drawing).
- Round end is supported by a 3” diameter metal column with height adjustment glide.
- Worksurfaces have one slimline grommet centered along the back edge.

- Meets BIFMA standard x5.1993
- 72” worksurfaces include reinforcing bars set into the underside of the worksurface.
- Specify trim color.
- Specify laminate color.

To order (Example): WPT244872-L-3L-XXX-WG  
 “P” Shaped Peninsula worksurface, 24-inch deep, 48-inch long, 72-inch deep at “P”, left-hand, 2mm PP edge, (laminate color), warm grey trim.”

Product	Depth	Length	Depth at “P”
WPT244860-L	24”	48”	60”
WPT244860-R	24”	48”	60”
WPT244872-L	24”	48”	72”
WPT244872-R	24”	48”	72”

Product	Depth	Length	Depth at “P”
WPT304872-L	30”	48”	72”
WPT304872-R	30”	48”	72”

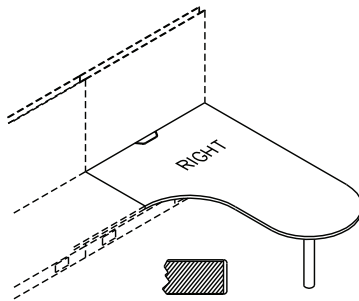

## Piano Peninsula Worksurfaces - 2mm PP Edge

- Piano Peninsula worksurfaces consist of 1-1/8” particle board between laminate and backer with 2mm PP edge banding around the perimeter of the surfaces.
- Includes worksurface supports.
- Cantilever brackets allow mounting to panels at 1” height increments.
- Specify Left-hand or Right-hand (see drawing).
- Round end is supported by a 3” diameter metal column with height adjustment glide.
- Worksurfaces have one slimline grommet centered along the back edge.

- Meets BIFMA standard x5.1993
- 72” worksurfaces include reinforcing bars set into the underside of the worksurface.
- Specify trim color.
- Specify laminate color.

To order (Example): WPP304872-R-3L-XXX-GR  
 “Piano Peninsula worksurface, 30-inch deep, 48-inch long, 72-inch deep at Piano, right-hand, 2mm PP edge, (laminate color), blue grey trim.”

Product	Depth	Length	Depth at Piano
WPP244860-L	24”	48”	60”
WPP244860-R	24”	48”	60”
WPP244872-L	24”	48”	72”
WPP244872-R	24”	48”	72”

Product	Depth	Length	Depth at Piano
WPP304872-L	30”	48”	72”
WPP304872-R	30”	48”	72”

# Worksurfaces - 2mm Polypropylene (PP)

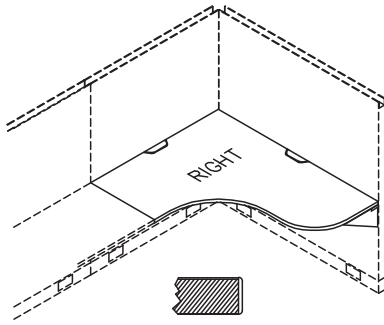

## Radius Shoe Worksurfaces - 2mm PP Edge

- Radiused Shoe worksurfaces consist of 1-1/8" particle board between laminate and backer with 2mm PP edge banding around the perimeter of the surfaces.
- Includes worksurface supports.
- Cantilever brackets allow mounting to panels at 1" height increments.
- Specify Left-hand or Right-hand (see drawing).
- 60" worksurfaces include reinforcing bars set into the underside of the worksurface.
- All surfaces 66" and longer are provided with an additional left-hand cantilever bracket for mid-surface support.

Product	Depth	Width	Length
WSP244860-L	24"	48"	60"
WSP244860-R	24"	48"	60"
WSP244866-L	24"	48"	66"
WSP244866-R	24"	48"	66"
WSP244872-L	24"	48"	72"
WSP244872-R	24"	48"	72"
WSP244884-L	24"	48"	84"
WSP244884-R	24"	48"	84"

- Meets BIFMA standard x5.1993
- Worksurfaces have one slimline grommet centered along both back edges.
- Specify trim color.
- Specify laminate color.

To order (Example): WSP244872-L-3L-XXX-SA  
 "Radius Shoe worksurface, 24-inch ends, 48-inch short back edge, 72-inch long back edge, left-hand, 2mm PP edge, (laminate color), sand trim."

Product	Depth	Width	Length
WSP304866-L	30"	48"	66"
WSP304866-R	30"	48"	66"
WSP304872-L	30"	48"	72"
WSP304872-R	30"	48"	72"
WSP304884-L	30"	48"	84"
WSP304884-R	30"	48"	84"

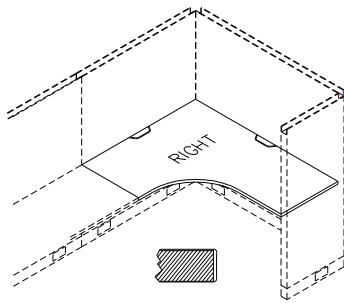

## Square Shoe Worksurfaces - 2mm PP Edge

- Square Shoe worksurfaces consist of 1-1/8" particle board between laminate and backer with 2mm PP edge banding around the perimeter of the surfaces.
- Includes worksurface supports.
- Cantilever brackets allow mounting to panels at 1" height increments.
- Specify Left-hand or Right-hand (see drawing).
- 60" worksurfaces include reinforcing bars set into the underside of the worksurface.
- All surfaces 66" and longer are provided with an additional left-hand cantilever bracket for mid-surface support.

Product	Depth	Width	Length
WSS244860-L	24"	48"	60"
WSS244860-R	24"	48"	60"
WSS244866-L	24"	48"	66"
WSS244866-R	24"	48"	66"
WSS244872-L	24"	48"	72"
WSS244872-R	24"	48"	72"
WSS244884-L	24"	48"	84"
WSS244884-R	24"	48"	84"

- Meets BIFMA standard x5.1993
- Worksurfaces have one slimline grommet centered along both back edges.
- Specify trim color.
- Specify laminate color.

To order (Example): WSS244866-R-3L-XXX-WG  
 "Radius Shoe worksurface, 24-inch ends, 48-inch short back edge, 66-inch long back edge, right-hand, 2mm PP edge, (laminate color), warm grey trim."

Product	Depth	Width	Length
WSS304866-L	30"	48"	66"
WSS304866-R	30"	48"	66"
WSS304872-L	30"	48"	72"
WSS304872-R	30"	48"	72"
WSS304884-L	30"	48"	84"
WSS304884-R	30"	48"	84"

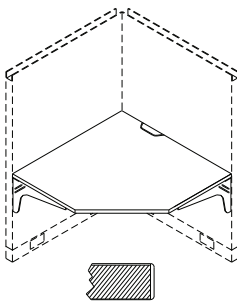

## 90° Diagonal Corner Worksurfaces - 2mm PP Edge

- 90° Diagonal Corner worksurfaces consist of 1-1/8" particle board between laminate and backer with 2mm PP edge banding around the perimeter of the surfaces.
- Includes worksurface supports.
- Cantilever brackets allow mounting to panels at 1" height increments.
- A left-hand cantilever bracket is provided for back corner.
- One slimline grommet located 12" from back corner along right rear edge.

- Meets BIFMA standard x5.1993
- Specify trim color.
- Specify laminate color.

To order (Example): WD244830-3L-XXX-BL  
 "90° Diagonal Corner worksurface, 24-inch left end, 48-inch back edges, 30-inch right end, 2mm PP edge, (laminate color), black trim."

Product	Left Depth	Panel Edge Length	Right Depth	Front Edge
WD243624	24"	36"	24"	16 1/4"
WD244224	24"	42"	24"	25 1/2"
WD244230	24"	42"	30"	21 1/2"
WD244824	24"	48"	24"	33 3/4"
WD244830	24"	48"	30"	30"

Product	Left Depth	Panel Edge Length	Right Depth	Front Edge
WD304224	30"	42"	24"	21 1/2"
WD304230	30"	42"	30"	16 3/4"
WD304824	30"	48"	24"	30"
WD304830	30"	48"	30"	25 1/2"

# Worksurfaces - 2mm Polypropylene (PP)

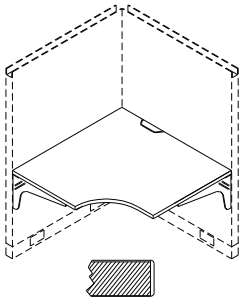

## 90° Curvilinear Corner Worksurfaces - 2mm PP Edge

- 90° Curvilinear Corner worksurfaces consist of 1-1/8" particle board between laminate and backer with 2mm PP edge banding around the perimeter of the surfaces.
- Includes worksurface supports.
- Cantilever brackets allow mounting to panels at 1" height increments.
- A left-hand cantilever bracket is provided for back corner.
- One slimline grommet located 12" from back corner along right rear edge.
- Meets BIFMA standard x5.1993.

- Specify trim color.
- Specify laminate color.

To order (Example): WC304824-3L-XXX-GR  
 "90° Curvilinear Corner worksurface, 30" left end, 48" back edges, 24" right end, 2mm PP edge, (laminate color), blue grey trim."

Product	Left Depth	Back Edge Length	Right Depth
WC243624	24"	36"	24"
WC244224	24"	42"	24"
WC244824	24"	48"	24"
WC303630	30"	36"	30"
WC304230	30"	42"	30"

Product	Left Depth	Panel Edge Length	Right Depth
WC304830	30"	48"	30"
WC244230	24"	42"	30"
WC304224	30"	42"	24"
WC244830	24"	48"	30"
WC304824	30"	48"	24"



# Worksurfaces - 2mm Polypropylene (PP)

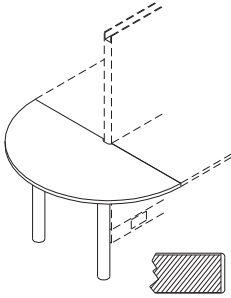

## Conference End Worksurfaces - 2mm PP Edge

- Conference End worksurfaces consist of 1-1/8" particle board between laminate and backer with 2mm PP edge banding around the perimeter of the surfaces.
- Includes worksurface supports.
- Worksurface includes two 3" diameter metal legs with adjustable glides, and connecting hardware to attach it to the ends of the other worksurfaces.
- Meets BIFMA standard x5.1993.

- Specify trim color.
- Specify laminate color.

To order (Example): WCE3151-3L-XXX-BL  
 "Conference end worksurface, 31-inches deep at middle of radius, 51-inches wide along flat edge, 2mm PP edge, (laminate color), black trim."

Product	Depth at Middle Radius	Width of Flat Edge	Connects Two Surfaces
WCE2551	25"	51"	24"
WCE3151	31"	51"	24"
WCE3163	31"	63"	30"
WCE3763	37"	63"	30"

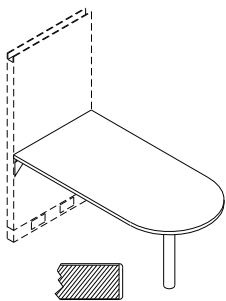

## "D" Shaped Peninsula Worksurface - (Panel Mount) - 2mm PP Edge

- D-shaped worksurfaces end mount to panels at 29"-30" height.
- D-shaped worksurfaces consist of 1-1/8" particle board between laminate and backer with 2mm PP edge banding around the perimeter of the surfaces.
- Includes worksurface supports.
- Brackets allow mounting to panels at 1" height increments.
- The round end is supported by a 3" diameter metal column with adjustable glides.
- 72" worksurfaces contain two steel reinforcing bars.

- Includes mounting hardware.
- Meets BIFMA standard x5.1993.
- Specify trim color.
- Specify laminate color.

To order (Example): WP3054-3L-XXX-SA  
 "'D" shaped peninsula worksurface (Panel Mount), 30-inches wide, 54-inches long, 2mm PP edge, (laminate color), sand trim."

Product	Depth	Length	Product	Depth	Length
WP3048	30"	48"	WP3072	30"	72"
WP3054	30"	54"	WP3660	36"	60"
WP3060	30"	60"	WP3672	36"	72"

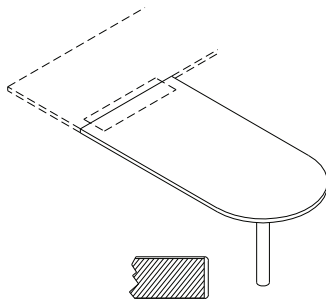

## "D" Shaped Peninsula Worksurface - (Side Mount) - 2mm PP Edge

- D-shaped worksurfaces side mount to panels at 29"-30" height.
- D-shaped worksurfaces consist of 1-1/8" particle board between laminate and backer with 2mm PP edge banding around the perimeter of the surfaces.
- Includes worksurface supports.
- The round end is supported by a 3" diameter metal column with adjustable glides.
- 72" worksurfaces contain two steel reinforcing bars.

- Includes mounting hardware.
- Meets BIFMA standard x5.1993.
- Specify trim color.
- Specify laminate color.

To order (Example): WSMP3060-3L-XXX-SA  
 "'D" shaped peninsula worksurface (End Mount), 30-inches wide, 60-inches long, 2mm PP edge, (laminate color), sand trim."

Product	Depth	Width
WSMP3048	30"	48"
WSMP3060	30"	60"
WSMP3072	30"	72"

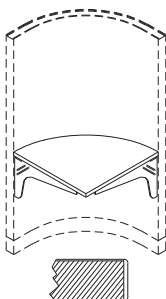

## Curved Worksurface - 2mm PP Edge

- Curved worksurfaces consist of 1-1/8" particle board between laminate and backer with 2mm PP edge banding around the perimeter of the surfaces.
- Worksurface is typically used so radius corresponds to curved panels.
- Sides match up to 24" deep worksurfaces.
- Includes worksurface cantilever brackets.
- Meets BIFMA standard x5.1993.

- Specify trim color.
- Specify laminate color.

To order (Example): WSC24-3L-XXX-BL  
 "Curved worksurface, 2mm PP edge, (laminate color), black trim."

Product	Depth
WSC24	24"

# Worksurfaces - 2mm Polypropylene (PP)

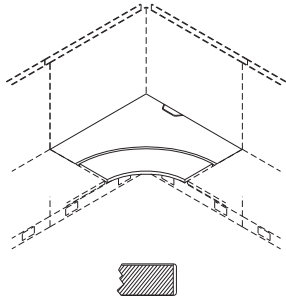

## Dual Curvilinear 90° Corner with Mechanism - 2mm PP Edge

- Dual curvilinear 90° corner with Mechanism consists of 1-1/8" particle board between laminate and backer with 2mm PP edge banding around the perimeter of the surfaces.
- Includes worksurface supports.
- Cantilever brackets allow mounting to panels at 1" height increments.
- Rear surface remains stationary and front surface provides height and tilt adjustment.
- Height adjustment mechanism adjusts 5 3/4" below, and 7" above the rear surface.
- Tilt adjustment of 9° positive, 15° negative.
- Meets BIFMA standard x5.1993.
- Spring assist mechanism will lift five pounds of equipment located on the keyboard surface. Higher capacity mechanisms are available as special orders.
- Mounting hardware included.
- Specify trim color.
- Specify laminate color.

To order (Example): WDC304830-3L-XXX-GR  
 "Dual curvilinear 90° corner worksurface with Mechanism, 30" wide left end, 48" back edges, 30" wide right end, 2mm PP edge, (laminate color), blue grey trim."

Product	Left Depth	Back Edge Length	Right Depth
WDC244224	24"	42"	24"
WDC244824	24"	48"	24"
WDC304830	30"	48"	30"

# Countertops - Bullnose T-Edge

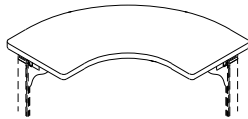
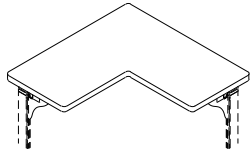
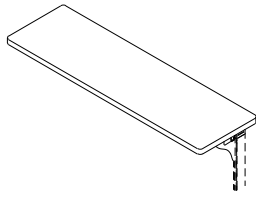

## Countertops - T-edge

- Constructed of 1-1/8" particle board between laminate and backer with vinyl T-edge around the perimeter of the surfaces.
- Includes supports for inside of workstation. Counter top extends 4" into space on outside of workstation.
- Right angle countertop provides 90° top for two panels the same size (24", 30", 36").
- Curved countertop provides top for curved panel.
- Specify laminate color.

- Meets BIFMA standard x5.1993.
- Specify trim color.
- Meets ADA requirements.
- For use on panels 42" or higher.

To order (Example) ST-CTA-24-GR-XXX  
 "Countertop, 24" width, blue grey trim, (laminated color number)."

Product	Type	Corresponding Panel Width	Depth
ST-CTA-24	Straight	24"	16"
ST-CTA-30	Straight	30"	16"
ST-CTA-36	Straight	36"	16"
ST-CTA-42	Straight	42"	16"
ST-CTA-48	Straight	48"	16"
ST-CTA-54	Straight	54"	16"
ST-CTA-60	Straight	60"	16"
ST-CTA-66	Straight	66"	16"
ST-CTA-72	Straight	72"	16"
ST-CTA-84	Straight	84"	16"
ST-CTA-9024RA	Right Angle	24"	16"
ST-CTA-9030RA	Right Angle	30"	16"
ST-CTA-9036RA	Right Angle	36"	16"
ST-CCT-24	Curved	Curved	16"

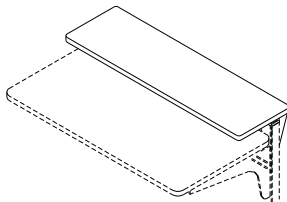

## Straight Countertop (For 32" High Panel) - T-edge

- Countertop is the same as a standard countertop. Mounting brackets are different to prevent interference with worksurface on 32" high panels.
- Meets BIFMA standard x5.1993.

To order (Example): ST-CTA-24-BN/32

Product	Corresponding Panel Width
ST-CTA-24-BN/32	24"
ST-CTA-30-BN/32	30"
ST-CTA-36-BN/32	36"
ST-CTA-42-BN/32	42"
ST-CTA-48-BN/32	48"
ST-CTA-54-BN/32	54"
ST-CTA-60-BN/32	60"
ST-CTA-72-BN/32	72"

# Countertops - Bullnose T-Edge

## 90° Countertops (For 32" High Panel) - T-edge

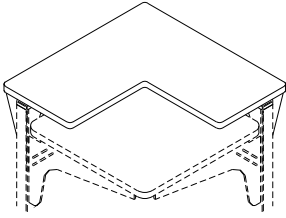

- Countertop is the same as a standard countertop.
- Mounting brackets are different to prevent interference with worksurface on 32" high panels.
- Meets BIFMA standard x5.1993.

To order (Example): ST-CTA-9024RA-BN/32-BL-XXX  
"90° countertops, black trim, laminate color number."

### Product

ST-CTA-9024RA-BN/32

ST-CTA-9030RA-BN/32

ST-CTA-9036RA-BN/32

## Curved Countertops (For 32" High Panel) - T-edge

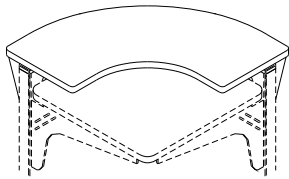

- Countertop is the same as a standard countertop.
- Mounting brackets are different to prevent interference with worksurface on 32" high panels.
- Meets BIFMA standard x5.1993.

To order (Example): ST-CTA-24CV-BN/32-BL-XXX  
"Curved countertop, black trim, laminate color number."

### Product

ST-CTA-24CV-BN/32

# Countertops - 2mm Polypropylene (PP)

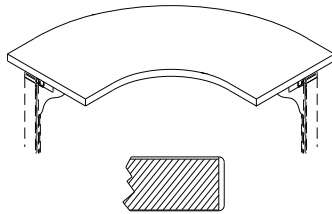
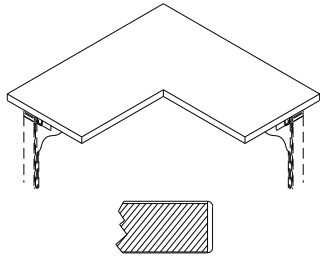
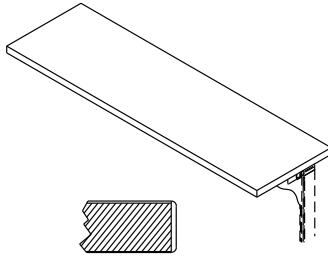

- Countertops consist of 1-1/8" particle board sandwiched between laminate and backer with 2mm PP edge banding around the perimeter.
- Includes supports on inside of workstation. Counter top extends 4" into space on outside of workstation.
- Right angle countertop provides 90° top for two panels the same size (24", 30", 36").
- Curved countertop provides top for curved panel.
- Meets BIFMA standard x5.1993.

- Meets ADA requirements.
- For use on panels 42" or higher.
- Specify laminate color.
- Specify trim color.

To order (Example) W9030-3L-XXX-BL.  
 "90° countertop for 30" wide panels, 2mm PP edge, (laminate color number), black trim."

Product	Type	Corresponding Panel Width	Depth
WCT24-3L	Straight	24"	16"
WCT30-3L	Straight	30"	16"
WCT36-3L	Straight	36"	16"
WCT42-3L	Straight	42"	16"
WCT48-3L	Straight	48"	16"
WCT54-3L	Straight	54"	16"
WCT60-3L	Straight	60"	16"
WCT66-3L	Straight	66"	16"
WCT72-3L	Straight	72"	16"
WCT78-3L	Straight	78"	16"
WCT84-3L	Straight	84"	16"
W9024-3L	Right Angle	24"	16"
W9030-3L	Right Angle	30"	16"
W9036-3L	Right Angle	36"	16"
WCCT24-3L	Curved	Curved	16"

# Countertops - 2mm Polypropylene (PP)

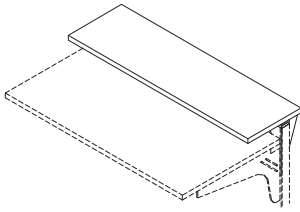

## Straight Countertop (For 32" High Panel) - 2mm PP Edge

- Countertop is the same as a standard countertop.
- Mounting brackets are different to prevent interference with worksurface on 32" high panels.
- Meets BIFMA standard x5.1993.

To order (Example) WCTWC30-3L-XXX-SA  
 "Straight countertop for 32" panels, 30" long, 2mm PP edge, (laminate color number), sand trim."

Product	Corresponding Panel Width
WCTWC24-3L	24"
WCTWC30-3L	30"
WCTWC36-3L	36"
WCTWC42-3L	42"
WCTWC48-3L	48"
WCTWC54-3L	54"
WCTWC60-3L	60"
WCTWC72-3L	72"
WCTWC78-3L	78"
WCTWC84-3L	84"

## 90° Countertop (For 32" High Panel) - 2mm PP Edge

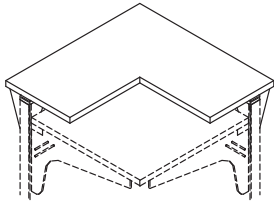

- Countertop is the same as a standard countertop.
- Mounting brackets are different to prevent interference with worksurface on 32" high panels.
- Meets BIFMA standard x5.1993.

To order (Example) WCTWC9036-3L-XXX-WG  
 "90° countertop for 32" panels, 36" wide, 2mm PP edge, (laminate color number), warm grey trim."

Product
WCTWC9024-3L
WCTWC9030-3L
WCTWC9036-3L

## Curved Countertop (For 32" High Panel) - 2mm PP Edge

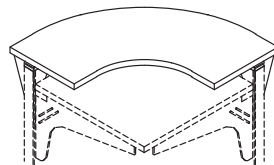

- Countertop is the same as a standard countertop.
- Mounting brackets are different to prevent interference with worksurface on 32" high panels.
- Meets BIFMA standard x5.1993.

To order (Example) WCCTWC24-3L-XXX-BL  
 "Curved countertop for 32" panels, 2mm PP edge, (laminate color number), black trim."

Product
WCCTWC24-3L

# Worksurface Accessories

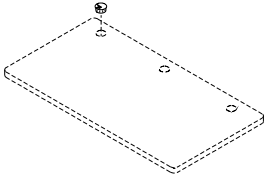

## Round Grommets - Factory Installed on T-edge Worksurfaces

- NOTE: To specify factory-installed grommets in left, center or right positions, add /L, /C, or /R to the end of the worksurface model number. If grommets are needed in more than one position, designate with two or three letters reading from left to right.

- Specify trim color.

To order (Example): CI-WS-2436-GR-XXX-LR  
Includes Grommets in left and right positions.

Product	Grommet Position
/L	Left
/C	Center
/R	Right

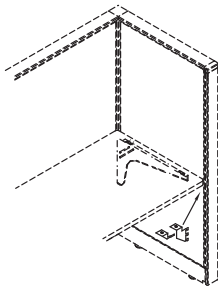

## Worksurface Support Bracket & Lock Clip

- Provides auxiliary support at front edge of worksurface where pedestals or heavy equipment requires additional worksurface support.
- Worksurface depth must match return panel width.
- Should not be used in place of a cantilever bracket.

- Specify trim color.

To order (Example): CI-WSB-L-BL  
"Worksurface support bracket, left hand, black."

Product	Width	Depth
CI-WSB-L	3"	4"
CI-WSB-R	3"	4"

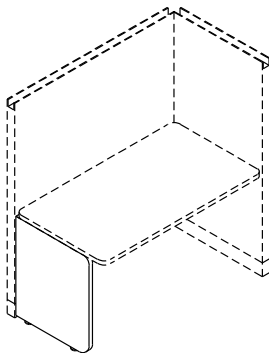

## Worksurface Support Panel - T-edge

- Available in fabric one side/laminate other side, or laminate on both sides.
- Support panel provides additional worksurface support in excessive worksurface loading applications.
- Mounts to panels. Screws to worksurface.
- Adjustable glides provide leveling capability.
- Must specify left or right side version by adding -L (left) or -R (right) to product number.**
- Specify trim color.
- Specify fabric color (if fabric/laminate combination is desired.)
- Available in 26" and 29" heights.
- Meets BIFMA standard x5.1993.

- Specify laminate color. If specifying laminate on both sides, add a "2" before the laminate color (i.e. /2).

To order fabric/laminate version (Example):  
CI-WSSP-2029-L-GR-XXX-XXX  
"Worksurface Support Panel, 20-inch depth, 29-inch height, left side version, blue grey trim color, (laminate color number)."

To order laminate/laminate version (Example):  
CI-WSSPL-2029-R-GR-2XXX  
Worksurface Support Panel, 20-inch depth, 29-inch height, right side version, blue grey trim color, both sides (laminate color number)."

### Fabric/Laminate

Product	Depth	Height
CI-WSSP-2026	20"	26"
CI-WSSP-2426	24"	26"
CI-WSSP-3026	30"	26"
CI-WSSP-2029	20"	29"
CI-WSSP-2429	24"	29"
CI-WSSP-3029	30"	29"

### Laminate/Laminate

Product	Depth	Height
CI-WSSPL-2026	20"	26"
CI-WSSPL-2426	24"	26"
CI-WSSPL-3026	30"	26"
CI-WSSPL-2029	20"	29"
CI-WSSPL-2429	24"	29"
CI-WSSPL-3029	30"	29"

# Worksurface Accessories

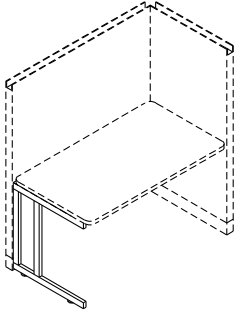

## C-Leg Supports

- 1 x 2 steel leg assembly used for additional worksurface support in excessive worksurface loading applications.
- Mounts to the panel. Screws to worksurface.
- Adjustable glides provide leveling capability.
- Must specify left or right side version by adding -L (left) or -R (right) to product number.

- Specify trim color.

To order (Example): CI-CLEG-2429-R-BL  
 "C-Leg, 24" width, 29" height, right, black color."

Product	Width	Height	End of Worksurface
CI-CLEG-2429-L	24"	29"	Left
CI-CLEG-2429-R	24"	29"	Right
CI-CLEG-3029-L	30"	29"	Left
CI-CLEG-3029-R	30"	29"	Right

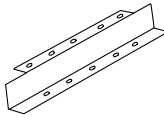

## Worksurface Vertical Filler

- Steel bracket connects worksurfaces with 3" height differences.
- Fills gap between surfaces to prevent accidental dropping of work tools or paper.

- Specify trim color.

To order (Example): CI-WSVF-20-BL  
 "Worksurface Vertical Filler, 20-inch width, black trim."

Product	Height	Depth
CI-WSVF-20	3"	20"
CI-WSVF-24	3"	24"
CI-WSVF-30	3"	30"

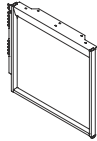

## Panel Mounted, Worksurface Support Open Leg

- 29" standard worksurface height.
- Features bracketry to attach to panel frame.
- Left orientation shown in image.
- Specify width by worksurface depth.
- Specify orientation (left or right).
- Specify trim color.

To order (Example): PSL3029/L/3L/BL  
 "Panel Mounted Open Support Leg - 30 inch width, 29 inch height, left orientation, black."

Product	W	H
SPSL1829	18"	29"
SPSL2429	24"	29"
SPSL3029	30"	29"

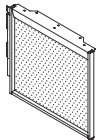

## Panel Mounted, Worksurface Support Insert Leg

- 29" standard worksurface height.
- Features bracketry to attach to panel frame.
- Left orientation shown in image.
- Specify width by worksurface depth.
- Specify orientation (left or right).
- Specify trim color.

To order (Example): PSLI2429/R/3L/WG  
 "Panel Mounted Support Insert Leg - 24 inch width, 29 inch height, right orientation, warm grey."

Product	W	H
SPSLI1829	18"	29"
SPSLI2429	24"	29"
SPSLI3029	30"	29"



# Overhead Panel Storage - Laminate End

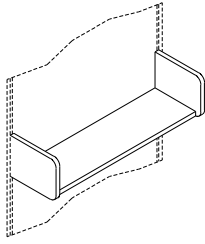

## Low Shelf

- 9" high monochromatic laminate covered particle board end panels with vinyl T-edge molding.
- Steel shelf.
- Meets BIFMA standards: X5.6-1993.
- Accepts shelf dividers.

- End panel bracket design prevents accidental dislodging of components.
- Specify trim color.  
To order (Example): CI-LS-24-GR  
"Low Shelf, 24-inch width, blue grey trim."

Product	Width	Height	Depth
CI-LS-24	24"	9 $\frac{1}{4}$ "	13 $\frac{3}{8}$ "
CI-LS-30	30"	9 $\frac{1}{4}$ "	13 $\frac{3}{8}$ "
CI-LS-36	36"	9 $\frac{1}{4}$ "	13 $\frac{3}{8}$ "
CI-LS-42	42"	9 $\frac{1}{4}$ "	13 $\frac{3}{8}$ "
CI-LS-48	48"	9 $\frac{1}{4}$ "	13 $\frac{3}{8}$ "
CI-LS-54	54"	9 $\frac{1}{4}$ "	13 $\frac{3}{8}$ "
CI-LS-60	60"	9 $\frac{1}{4}$ "	13 $\frac{3}{8}$ "

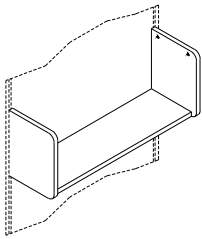

## Regular Shelf

- 15" high monochromatic laminate covered particle board end panels with vinyl T-edge molding.
- Steel shelf.
- Meets BIFMA standards: X5.6-1993.
- Accepts shelf dividers.

- End panel bracket design prevents accidental dislodging of components.
- Specify trim color.  
To order (Example): CI-RS-24-SA  
"Regular Shelf, 24-inch width, sand trim."

Product	Width	Height	Depth
CI-RS-24	24"	15 $\frac{5}{8}$ "	13 $\frac{3}{8}$ "
CI-RS-30	30"	15 $\frac{5}{8}$ "	13 $\frac{3}{8}$ "
CI-RS-36	36"	15 $\frac{5}{8}$ "	13 $\frac{3}{8}$ "
CI-RS-42	42"	15 $\frac{5}{8}$ "	13 $\frac{3}{8}$ "
CI-RS-48	48"	15 $\frac{5}{8}$ "	13 $\frac{3}{8}$ "
CI-RS-54	54"	15 $\frac{5}{8}$ "	13 $\frac{3}{8}$ "
CI-RS-60	60"	15 $\frac{5}{8}$ "	13 $\frac{3}{8}$ "

# Overhead Panel Storage - Laminate End

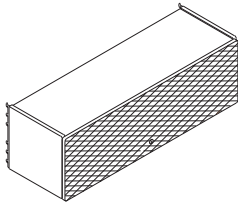

## Fabric Flipper Door

- 15" high monochromatic laminate covered particle board end panels with vinyl T-edge molding.
- Steel bottom and top shelves and fabric-covered front.
- Meets BIFMA standards: X5.6-1993.
- End panel bracket design prevents accidental dislodging of components.
- Door opens above cabinet.

- Lock is included with 2 keys.
- Available with key-alike option.
- Specify trim color.

To order (Example): CI-FDF-24-GR-XXX  
 "Fabric Flipper Door, 24-inch width, blue grey trim (fabric color number)."

Product	Width	Height	Depth
CI-FDF-24	24"	15 $\frac{5}{8}$ "	14 $\frac{3}{8}$ "
CI-FDF-30	30"	15 $\frac{5}{8}$ "	14 $\frac{3}{8}$ "
CI-FDF-36	36"	15 $\frac{5}{8}$ "	14 $\frac{3}{8}$ "
CI-FDF-42	42"	15 $\frac{5}{8}$ "	14 $\frac{3}{8}$ "
CI-FDF-48	48"	15 $\frac{5}{8}$ "	14 $\frac{3}{8}$ "
CI-FDF-54	54"	15 $\frac{5}{8}$ "	14 $\frac{3}{8}$ "
CI-FDF-60	60"	15 $\frac{5}{8}$ "	14 $\frac{3}{8}$ "

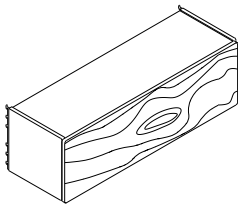

## Laminate Flipper Door

- 15" high monochromatic laminate covered particle board end panels with vinyl T-edge molding.
- Steel bottom and top shelves and laminate front surface.
- Meets BIFMA standards: X5.6-1993.
- End panel bracket design prevents accidental dislodging of components.
- Door opens above cabinet.
- Lock is included with 2 keys.

- Available with key-alike option.
- Specify trim color.
- Specify laminate color.

To order (Example): CI-FDL-24-SA-XXX  
 "Laminate Flipper Door, 24-inch width, sand trim (laminate color number)."

Product	Width	Height	Depth
CI-FDL-24	24"	15 $\frac{5}{8}$ "	14 $\frac{3}{8}$ "
CI-FDL-30	30"	15 $\frac{5}{8}$ "	14 $\frac{3}{8}$ "
CI-FDL-36	36"	15 $\frac{5}{8}$ "	14 $\frac{3}{8}$ "
CI-FDL-42	42"	15 $\frac{5}{8}$ "	14 $\frac{3}{8}$ "
CI-FDL-48	48"	15 $\frac{5}{8}$ "	14 $\frac{3}{8}$ "
CI-FDL-54	54"	15 $\frac{5}{8}$ "	14 $\frac{3}{8}$ "
CI-FDL-60	60"	15 $\frac{5}{8}$ "	14 $\frac{3}{8}$ "

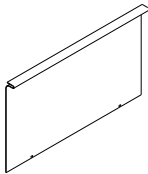

## Flipper Door Unit Backs

- Optional steel back attaches to laminate end flipper door unit. (CI-FDF, FDL, FDS)
- Specify trim color.

To order (Example): CI-FDB-24-BL  
 "Flipper Door Unit Back, 24-inch width, black trim."

Product	Width	Height
CI-FDB-24	24"	15 $\frac{5}{8}$ "
CI-FDB-30	30"	15 $\frac{5}{8}$ "
CI-FDB-36	36"	15 $\frac{5}{8}$ "
CI-FDB-42	42"	15 $\frac{5}{8}$ "
CI-FDB-48	48"	15 $\frac{5}{8}$ "
CI-FDB-54	54"	15 $\frac{5}{8}$ "
CI-FDB-60	60"	15 $\frac{5}{8}$ "

# Overhead Panel Storage - Laminate End

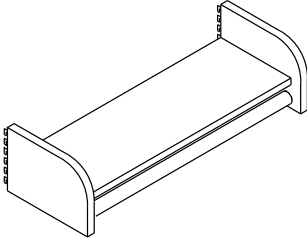

## Coat Rack

- 9" laminate covered particle board end panel with vinyl T-edge molding.
- Steel storage shelf located above steel chrome plated hanging rod.
- End panel bracket design prevents accidental dislodgement.
- End panels are monochromatic.
- Meets BIFMA standards: X5.6 1993.

- Specify trim color.

To order (Example): CI-CR-24-GR  
"Coat Rack, 24-inch wide, blue grey finish."

Product	Width	Height	Depth
CI-CR-24	24"	9 $\frac{1}{4}$ "	13 $\frac{5}{8}$ "
CI-CR-30	30"	9 $\frac{1}{4}$ "	13 $\frac{5}{8}$ "
CI-CR-36	36"	9 $\frac{1}{4}$ "	13 $\frac{5}{8}$ "
CI-CR-42	42"	9 $\frac{1}{4}$ "	13 $\frac{5}{8}$ "
CI-CR-48	48"	9 $\frac{1}{4}$ "	13 $\frac{5}{8}$ "
CI-CR-54	54"	9 $\frac{1}{4}$ "	13 $\frac{5}{8}$ "

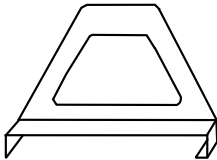

## Shelf Dividers

- Steel shelf dividers work on laminate end low shelves, regular shelves, flipper door units, and coat racks.
- Specify trim color.

To order (Example): CI-SD-GR  
"Shelf Divider, blue grey trim."

Product	Height	Depth
CI-SD	8"	13"
CI-SD-8 (8 pack)	8"	13"

# Overhead Panel Storage - Steel End

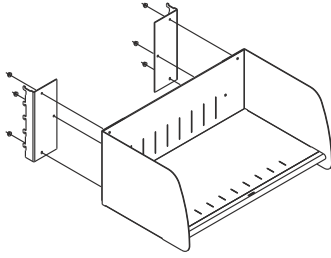

## Low Shelf

- 10½" high steel ends with radiused front edge.
- 13½" deep steel shelf with 10½" high back is slotted to accept shelf dividers.
- Meets BIFMA standards X5.6-1993.
- Radiused edge the full width of shelf front.
- End panel bracket design prevents accidental dislodging of components.

Product	Width	Height	Depth
ULSR-24/X1	24"	10½"	15"
ULSR-30/X1	30"	10½"	15"
ULSR-36/X1	36"	10½"	15"
ULSR-42/X1	42"	10½"	15"
ULSR-48/X1	48"	10½"	15"
ULSR-54/X1	54"	10½"	15"
ULSR-60/X1	60"	10½"	15"

- Specify trim color.

To order (Example) ULSR-36-X1-BL  
"Low shelf, 36-inch wide, black paint."

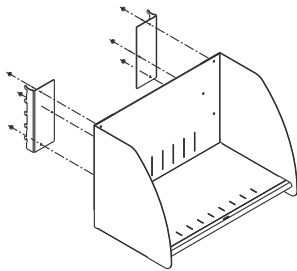

## Regular Shelf

- 16½" high steel ends with radiused front edge.
- 13½" deep steel shelf with 16½" high back is slotted to accept shelf dividers.
- Meets BIFMA standards X5.6-1993
- Radiused edge the full width of shelf front.
- End panel bracket design prevents accidental dislodging of components.

Product	Width	Height	Depth
URSR-24/X1	24"	16½"	15"
URSR-30/X1	30"	16½"	15"
URSR-36/X1	36"	16½"	15"
URSR-42/X1	42"	16½"	15"
URSR-48/X1	48"	16½"	15"
URSR-54/X1	54"	16½"	15"
URSR-60/X1	60"	16½"	15"

- Specify trim color.

To order (Example) URSR-48-X1-SA  
"Regular shelf, 48-inch wide, sand paint."

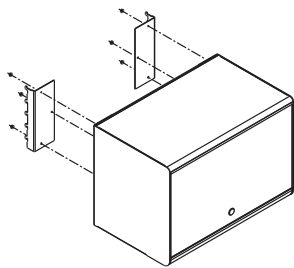

## Universal Overhead - Fabric Front

- 16½" high steel ends with radiused front corners.
- 13½" deep steel shelf with full back is slotted to accept shelf dividers.
- Steel top.
- Steel door is fabric covered, lockable, recedes inside the cabinet, and has a full length radiused handle.
- Meets BIFMA standards X5.6-1993.

- End panel bracket design prevents accidental dislodging of components.
- Specify trim color.

To order (Example) PRDF-30-X1-BL-XXX  
"Universal overhead fabric door, 30-inch wide, black paint, (fabric color number)."

Product	Width	Height	Depth
PRDF-24/X1	24"	16½"	14½"
PRDF-30/X1	30"	16½"	14½"
PRDF-36/X1	36"	16½"	14½"
PRDF-42/X1	42"	16½"	14½"
PRDF-48/X1	48"	16½"	14½"
PRDF-54/X1	54"	16½"	14½"
PRDF-60/X1	60"	16½"	14½"

# Overhead Panel Storage - Steel End

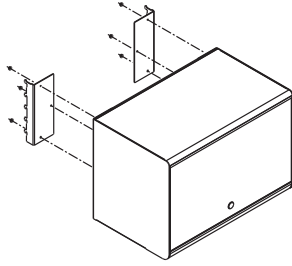

## Universal Overhead - Laminate Front

- 16½" high steel ends with radiused front corners.
- 13½" deep steel shelf with full back is slotted to accept shelf dividers.
- Steel top.
- Laminate covered 58" particle board door, lockable, recedes inside the cabinet, and has a full length radiused handle.
- End panel bracket design prevents accidental dislodging of components.

Product	Width	Height	Depth
PRDL-24/X1	24"	16½"	14½"
PRDL-30/X1	30"	16½"	14½"
PRDL-36/X1	36"	16½"	14½"
PRDL-42/X1	42"	16½"	14½"
PRDL-48/X1	48"	16½"	14½"
PRDL-54/X1	54"	16½"	14½"
PRDL-60/X1	60"	16½"	14½"

- Meets BIFMA standards X5.6-1993
- Specify trim color.

To order (Example) PRDL-42-X1-GR-XXX  
"Universal overhead laminate door, 42" wide, blue grey paint, (laminate color number)."

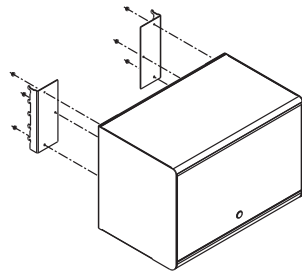

## Universal Overhead - Painted Steel Front

- 16½" high steel ends with radiused front corners.
- 13½" deep steel shelf with full back is slotted to accept shelf dividers.
- Steel top.
- Painted steel door, lockable, recedes inside the cabinet, and has a full length radiused handle.
- End panel bracket design prevents accidental dislodging of components.

Product	Width	Height	Depth
PRDS-24/X1	24"	16½"	14½"
PRDS-30/X1	30"	16½"	14½"
PRDS-36/X1	36"	16½"	14½"
PRDS-42/X1	42"	16½"	14½"
PRDS-48/X1	48"	16½"	14½"
PRDS-54/X1	54"	16½"	14½"
PRDS-60/X1	60"	16½"	14½"

- Meets BIFMA standards X5.6-1993
- Specify trim color.

To order (Example) PRDS-54-X1-WG  
"Universal overhead steel door, 54" wide, warm grey paint."

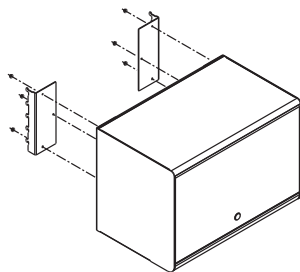

## Universal Overhead - Veneer Front

- 16½" high steel ends with radiused front corners.
- 13½" deep steel shelf with full back is slotted to accept shelf dividers.
- Steel top.
- Veneer covered 58" particle board door, lockable, recedes inside the cabinet, and has a full length radiused handle.
- End panel bracket design prevents accidental dislodging of components.

Product	Width	Height	Depth
PRDV-24/X1	24"	16½"	14½"
PRDV-30/X1	30"	16½"	14½"
PRDV-36/X1	36"	16½"	14½"
PRDV-42/X1	42"	16½"	14½"
PRDV-48/X1	48"	16½"	14½"
PRDV-54/X1	54"	16½"	14½"
PRDV-60/X1	60"	16½"	14½"

- Meets BIFMA standards X5.6-1993
- Specify trim color.

To order (Example) PRDV-24-X1-BL-XXX  
"Universal overhead veneer door, 24" wide, black paint, (veneer color number)."

# Overhead Panel Storage

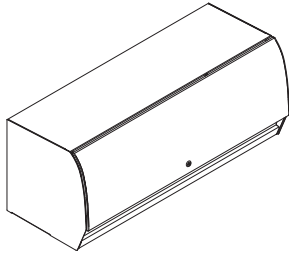

## Venus Solid Color Upper Door

- Colored or translucent extruded PVC door.
- Painted cabinet and lower door.
- Mounting brackets included.
- Shelf dividers available separately.
- Capable of shipping assembled.
- Will accept hanging tool rail and tackboards.  
(Attachment bar ordered separately).
- Meets BIFMA standards X5.6-1993.

- Specify trim color.

To order (Example): VNOS36/XI/BL/TR/KA  
"Venus 36" Solid Color Upper Door, 36 inch width,  
black paint, translucent upper door, keyed alike."

Product	W	H	D
VNOS30/X1	30"	17"	19¼"
VNOS36/X1	36"	17"	19¼"
VNOS42/X1	42"	17"	19¼"
VNOS48/X1	48"	17"	19¼"
VNOS54/X1	54"	17"	19¼"
VNOS60/X1	60"	17"	19¼"

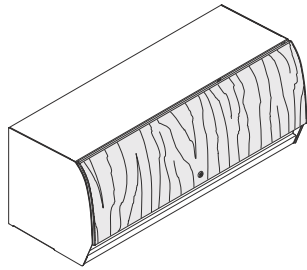

## Venus Laminate Upper Door

- Laminate upper door.
- Painted cabinet and lower door.
- Mounting brackets included.
- Shelf dividers available separately.
- Capable of shipping assembled.
- Will accept hanging tool rail and tackboards.  
(Attachment bar ordered separately).
- Meets BIFMA standards X5.6-1993.

- Specify trim color.

To order (Example): VNOL30/XI/SA/laminate code/KS  
"Venus Laminate Upper Door, 30 inch width, sand  
paint, laminate, keyed standard."

Product	W	H	D
VNOL30/X1	30"	17"	19¼"
VNOL36/X1	36"	17"	19¼"
VNOL42/X1	42"	17"	19¼"
VNOL48/X1	48"	17"	19¼"
VNOL54/X1	54"	17"	19¼"
VNOL60/X1	60"	17"	19¼"

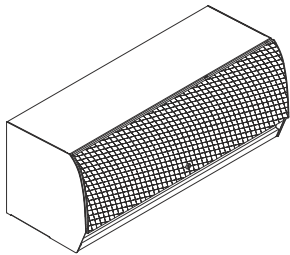

## Venus Fabric Upper Door

- Fabric covered upper door.
- Painted cabinet and lower door.
- Mounting brackets included.
- Shelf dividers available separately.
- Capable of shipping assembled.
- Will accept hanging tool rail and tackboards.  
(Attachment bar ordered separately).
- Meets BIFMA standards X5.6-1993.

- Specify trim color.

To order (Example): VNOF42//XI/WG/fabric code/KA  
"Venus Fabric Upper Door, 42 inch width, warm grey  
paint, fabric, keyed alike."

Product	W	H	D
VNOF30/X1	30"	17"	19¼"
VNOF36/X1	36"	17"	19¼"
VNOF42/X1	42"	17"	19¼"
VNOF48/X1	48"	17"	19¼"
VNOF54/X1	54"	17"	19¼"
VNOF60/X1	60"	17"	19¼"

# Overhead Panel Storage - Steel End

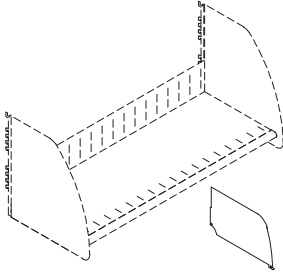

## Overhead Shelf Divider

- Steel shelf divider is powder coat painted.
- Fits all radiused front storage units.
- Specify trim color.

To order (Example) RFSD-SA  
"Radiused front shelf divider, sand paint."

### Product

RFSD

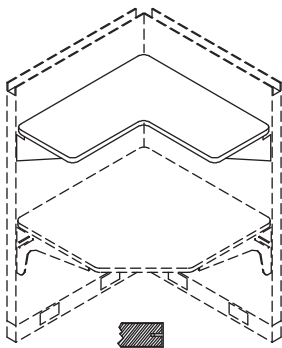

## Corner Book Shelf, T-edge

- Corner bookshelf consists of 1-1/8" particle board between laminate and backer with vinyl T-edge molding.
- Shelf surface is 16" deep.
- Included brackets allow mounting to panels at 1" height increments.
- Specify trim color.
- Specify laminate color.

To order (Example) CI-SFCB3636-BN-(XXX)-GR  
"Corner bookshelf 36" x 36", T-edge, (laminate color number), blue grey."

Product	Panel Size
CI-SFCB2424-BN	24" x 24"
CI-SFCB3030-BN	30" x 30"
CI-SFCB3636-BN	36" x 36"
CI-SFCB4242-BN	42" x 42"
CI-SFCB4848-BN	48" x 48"

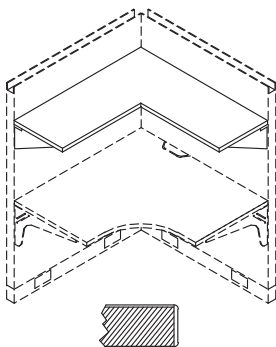

## Corner Book Shelf, 2mm PP edge

- Corner bookshelf consists of 1-1/8" particle board between laminate and backer with 2mm PP edge banding.
- Shelf surface is 16" deep.
- Included brackets allow mounting to panels at 1" height increments.
- Specify trim color.
- Specify laminate color.

To order (Example) CI-SFCB4848-3L-(XXX)-WG  
"Corner bookshelf 48" x 48", 3mm PVC edge, (laminate color number), warm grey."

Product	Panel Size
CI-SFCB2424-3L	24" x 24"
CI-SFCB3030-3L	30" x 30"
CI-SFCB3636-3L	36" x 36"
CI-SFCB4242-3L	42" x 42"
CI-SFCB4848-3L	48" x 48"

# Panel Hung Accessories

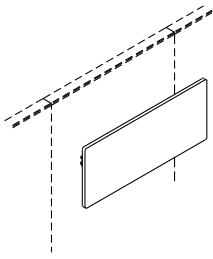

## Tackboards

- Tackboards are constructed of 3/4" tackable board and covered with fabric.
- Includes mounting brackets to allow mounting to panels of the same width in 1" height increments.

Product	Width	Height
CI-TB-2412	24"	12"
CI-TB-3012	30"	12"
CI-TB-3612	36"	12"
CI-TB-4212	42"	12"
CI-TB-4812	48"	12"
CI-TB-5412	54"	12"
CI-TB-6012	60"	12"
CI-TB-2416	24"	16"
CI-TB-3016	30"	16"
CI-TB-3616	36"	16"
CI-TB-4216	42"	16"
CI-TB-4816	48"	16"
CI-TB-5416	54"	16"
CI-TB-6016	60"	16"
CI-TB-2424	24"	24"

To order (Example): CI-TB-2412  
"Tackboard, 24-inch width, 12-inch height."

Product	Width	Height
CI-TB-3024	30"	24"
CI-TB-3624	36"	24"
CI-TB-4824	48"	24"
CI-TB-6024	60"	24"
CI-TB-2430	24"	30"
CI-TB-3030	30"	30"
CI-TB-3630	36"	30"
CI-TB-4230	42"	30"
CI-TB-4830	48"	30"
CI-TB-5430	54"	30"
CI-TB-6030	60"	30"
CI-TB-2448	24"	48"
CI-TB-3048	30"	48"
CI-TB-3648	36"	48"
CI-TB-4248	42"	48"
CI-TB-4848	48"	48"
CI-TB-6048	60"	48"

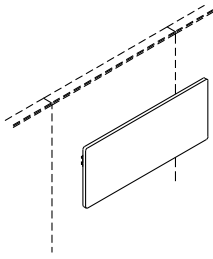

## Tackboards With Backer

- Tackboards are constructed of 3/4" tackable board laminated to a 1/4" masonite sheet and the front is covered with fabric.
- Includes mounting brackets to allow mounting to panels of the same width in 1" height increments.

Product	Width	Height
CI-TBB-2412	24"	12"
CI-TBB-3012	30"	12"
CI-TBB-3612	36"	12"
CI-TBB-4212	42"	12"
CI-TBB-4812	48"	12"
CI-TBB-6012	60"	12"
CI-TBB-2416	24"	16"
CI-TBB-3016	30"	16"
CI-TBB-3616	36"	16"
CI-TBB-4216	42"	16"
CI-TBB-4816	48"	16"
CI-TBB-6016	60"	16"

To order (Example): CI-TBB-2412  
"Tackboard with backer, 24-inch width, 12-inch height."

Product	Width	Height
CI-TBB-2430	24"	30"
CI-TBB-3030	30"	30"
CI-TBB-3630	36"	30"
CI-TBB-4230	42"	30"
CI-TBB-4830	48"	30"
CI-TBB-6030	60"	30"
CI-TBB-2448	24"	48"
CI-TBB-3048	30"	48"
CI-TBB-3648	36"	48"
CI-TBB-4248	42"	48"
CI-TBB-4848	48"	48"
CI-TBB-6048	60"	48"

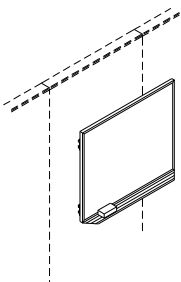

## Markerboards

- Includes markers and an eraser.
- Includes mounting brackets to allow mounting to panels of the same width in 1" height increments.
- White porcelain paint finished board surface.
- Available with white trim only.

Product	Width	Height
CI-MB-2416	24"	16"
CI-MB-3016	30"	16"
CI-MB-3616	36"	16"
CI-MB-4216	42"	16"
CI-MB-4816	48"	16"
CI-MB-6016	60"	16"

To order (Example): CI-MB-3632  
"Markerboard, 36-inch width x 32-inch height."

Product	Width	Height
CI-MB-2432	24"	32"
CI-MB-3032	30"	32"
CI-MB-3632	36"	32"
CI-MB-4232	42"	32"
CI-MB-4832	48"	32"
CI-MB-6032	60"	32"



# Miscellaneous Panel Accessories

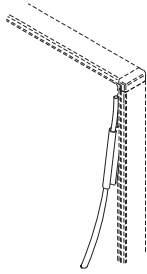

## Cord Manager

- Manages vertical cords above and below worksurfaces.
- Snaps into side trim rail.
- Can be field cut to any lengths.

- Specify trim color.

To order (Example): CI-CM-6-SA  
"Cord Manager, sand trim"

Product	Length
CI-CM-6	72"



## Wall Track

- Double-slotted track accommodates wall mounting of components.
- No attachment hardware included. See installation guidelines for mounting restrictions.

- Specify trim color.

To order (Example): CI-CWT-84-GR  
"Wall track 84-inch, blue grey trim."

Product	Width	Height	Depth
CI-CWT-66	1¼"	66"	1"
CI-CWT-84	1¼"	84"	1"

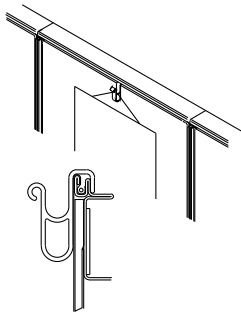

## Coat Hooks/Picture Hanger

- Plastic hook attaches under the top cap of the panel to support coat hanger or hang picture.
- Specify trim color.

To order (Example): CI-CH-GR  
"Coat Hooks, blue grey trim."

Product	Width
CI-CH (single)	¾"
CI-CH-12 (box of 12)	¾"

# Universal Electrical Connection Diagram

## 4-4-2

Receptacles available	Wires to be used	Gauge of wire
Circuit 1	Black White/Black Letters Green or Bare	12 12 12
Circuit 2	Red White/Black Letters Green or Bare	12 12 12
Circuit 3	Blue White/Black Letters Green/Yellow Stripe or Gray	12 12 12
Circuit 4	Pink White/Purple Letters Green/Yellow Stripe or Gray	12 12 12

## Blue UL Label

### 4-4-2 Connection Diagrams

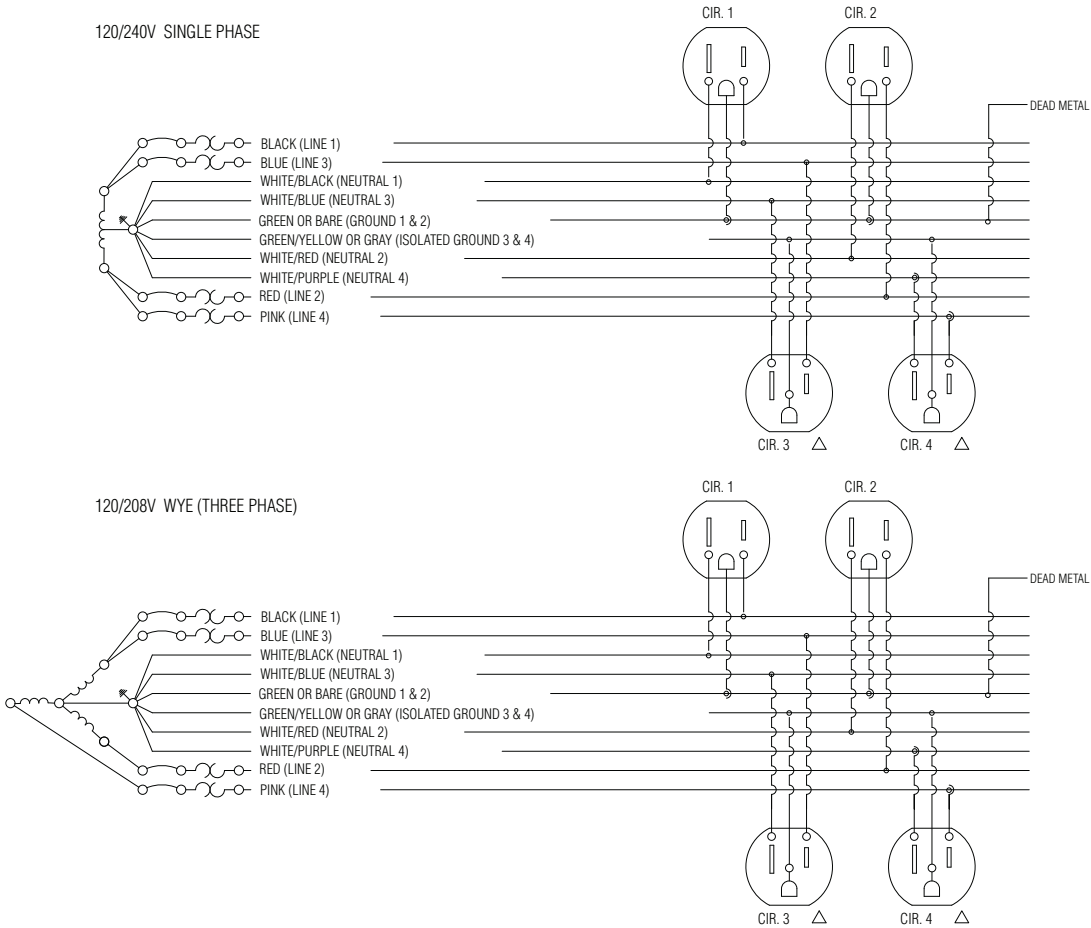

# Universal Electrical Connection Diagram

## 6-2-2

Receptacles available	Wires to be used	Gauge of wire
Circuit 1	Black White/Black Letters Green or Bare	12 10 12
Circuit 2	Red White/Black Letters Green or Bare	12 10 12
Circuit 3	Blue White/Black Letters Green or Bare	12 10 12
Circuit 4l	Pink White/Red Letters Green/Yellow Stripe or Gray	12 10 12
Circuit 5l	Tan White/Red Letters Green/Yellow Stripe or Gray	12 10 12
Circuit 6l	Orange White/Red Letters Green/Yellow Stripe or Gray	12 10 12

## 6-2-2 Connection Diagrams

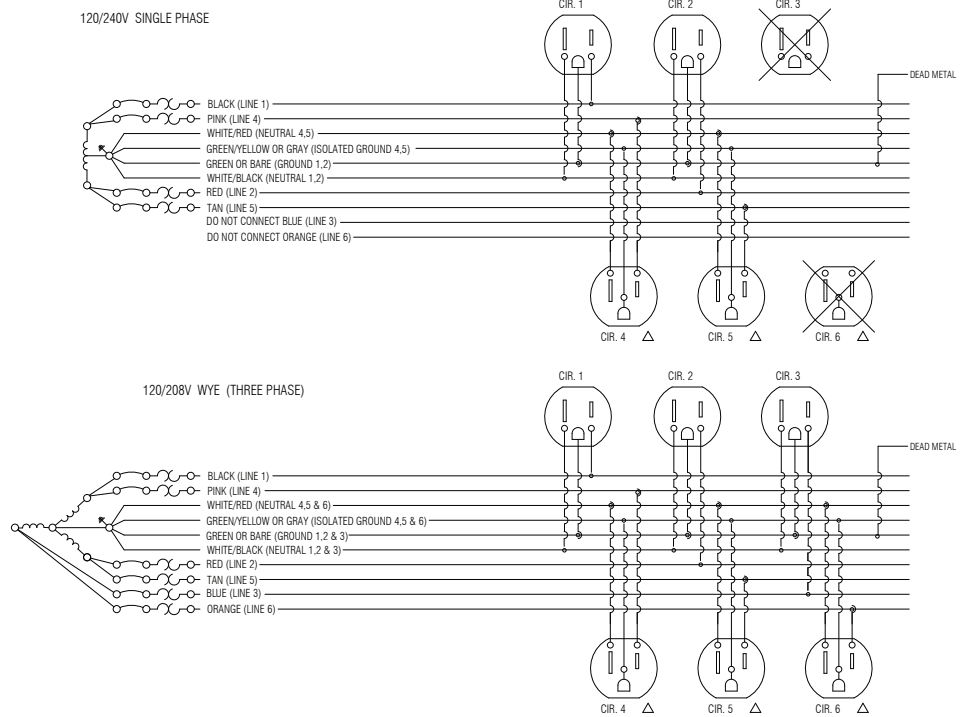

## Green UL Label

## 6-2-2 Connection Diagrams To An 8-Wire Building

